

#### WARNING

Please note that unauthorized (i) reception of cable service, (ii) satellite decoding, or (iii) video decoding or copying is illegal under Federal and State law. Federal law renders illegal both the interception and reception of any communication service offered over a cable or satellite system, or the decoding or copying of videos unless specifically authorized by law. Federal law imposes both civil and criminal penalties for violations of the applicable statutes. In addition, most if not all of the states have enacted "theft of cable services" statutes imposing penalties for violation thereof. Thus, the use of the unit described in this article should be restricted to educational, scientific, and/or informational purposes and prior to the use thereof authorization should be obtained from your cable service company, satellite transmission service or video producer. This is not intended to constitute legal advice as to the propriety of their use thereof based upon their individual circumstances and jurisdictions.

# UNIVERSAL DESCRAMBLER

*Restore missing video sync signals with our universal decoder.*

**RUDOLF F. GRAF and WILLIAM SHEETS**

WE'VE ALL ENCOUNTERED VIDEO SIGNALS with missing, weak, or noisy sync pulses that can make it difficult or impossible to use the signal. Those disturbances may cause rolling, tearing, or other instability in the displayed video image. The example we're most familiar with is a scrambled TV signal, or a Macrovision-encoded video tape. The unit will restore usable sync to virtually any video signal. You can use it to watch one scrambled show while taping another, to clean up Macrovision when watching a video tape, or to simply restore clean sync to a noisy video signal.

Another difficulty is that the video itself may be incorrectly phased (negative, for example). While that is more of an interface problem than a transmission problem, it usually results in a picture that has its tones reversed or colors shifted in hue due to phasing differences between the correct burst (reference) signal and the burst signal actually received.

Very often, the distortions are deliberately introduced into the video signal to prevent unauthorized reception, or to introduce other obstacles to

their misuse. One example is "copy guard," a technique used to discourage unauthorized copying of video tapes, and another case is scrambling, used on cable systems to prevent unauthorized viewing.

In order to deal with those problems, a dedicated "decoder" box or other such device is used. The device is generally useful for only one type of coding or scrambling scheme.

The technique of sync suppression and/or video inversion is used on both cable and satellite video transmissions. How that works is simple; the sync pulses are altered in either level

or total amplitude, or omitted entirely from the video (see Fig. 1). The video may also be inverted, although that is not always done. Sometimes the sync pulses may be suppressed to random levels, at different times. That is done to "confuse" unsophisticated decoders, and make video piracy more difficult.

With all of those schemes, a "key" or pilot signal must be sent along with the scrambled signal in order to properly reconstruct the missing or distorted sync signal. The key or pilot signal may take several forms. An audio-subcarrier, usually 15.7, 31.5 or



MAY 1990

94 kHz (or some other frequency that has a fixed ratio to the horizontal-sync frequency of 15.734 kHz) is added to the video signal, and is used by the decoder as a reference to reconstruct the sync signal. Sometimes a digital "addressing" signal is used to activate and deactivate the decoder. For our purposes, though, the addressing signals can be ignored since they are not involved in the scrambling and descrambling process.

Another method makes use of a series of horizontal pulses immediately following the vertical-sync pulses to phase lock a horizontal frequency oscillator in the decoder. That, in turn, is used to regenerate the missing or suppressed horizontal sync. That system is known as a "pilotless" method, and that's because no pilot subcarrier is sent along with the audio.

All of those methods have one thing in common: They all alter the sync information. But in order to decode the signal, there must be a key of some kind present in the signal that can be used to reconstruct the sync.

Sometimes, as a scrambling tech-

versed. Dark areas will be light, greens will appear as red, etc. One would assume that simply inverting the video would correct that problem. However, only the video must be inverted, not the sync. Sync must be left in original form. That requires separate sync and video channels and a means of splitting the video from the sync.

This article will discuss a single-circuit device that can be used to regenerate any of those distorted video signals. The device will:

1. Regenerate missing or distorted sync.
2. Remove interfering signals from the sync pulses due to scrambling, noise, etc.
3. Invert (or revert) video polarity.
4. Change the DC level of video (brightness).
5. Adjust the contrast levels (luminance).
6. Correct tint distortion (color shifts).
7. Generate scrambled video signals for testing decoders and scrambling/descrambling experiments.

Please note that the unit will work only on baseband video from DC to 4 MHz. It does not operate on audio signals.

**WARNING:** this device is intended for experimental use, and is definitely not intended for theft of scrambled material. See the box in the beginning of this article.

#### How it works

Present in all (NTSC) video signals is a color-burst component at 3.58 MHz. That signal is the "key" from which all other sync and timing information is derived. The horizontal frequency is related to the burst by a factor of  $227\frac{1}{2}$ , and the vertical frequency is related to the horizontal frequency by a factor of 525 (NTSC video only). If there is some burst signal present, even if noisy, the decoder system will be able to use it to generate the necessary signals. It will not remove video noise during the scan intervals (noisy picture), only the sync so that lockup is possible. Figure 2 is a block diagram of the sync regenerator.

Video input at J1 is split two ways: One portion goes through level-control R2 into a video amplifier. It is amplified by a factor of ten and fed to a polarity-selector circuit. The switch selects the desired polarity (usually

negative) and feeds it to a clamp circuit. There the blanking pedestal (blackest black) is clamped at zero volts DC, and the DC video level is established by referencing the scan portion (line scan) to a variable DC level set by the clamp or DC-level control. That feature allows independent control of scene brightness. Next, the video-plus-blanking signal is fed to a sync combiner where a pulse of approximately  $-0.4$  volts is added to the video. The output of the sync combiner is fed to a burst keyer where a new burst signal is added to the signal. Now we have a complete NTSC signal at the output of the burst keyer, having a zero-volt DC blanking level,  $-0.4$ -volt negative sync, and a 0- to 1-volt video level. A video output driver is used to interface a 75-ohm load to the output of the burst keyer.

The requisite components of the sync portion are derived from a CD2240 CMOS LSI video sync generator that operates from a 1.08-MHz clock circuit. The clock signal is generated by a clock oscillator that is phase locked to a reference derived from the original "defective" video signal as follows: The 3.58-MHz components are extracted by a 3.58-MHz filter and fed to a 3.58-MHz oscillator circuit. The circuit is similar to the 3.58-MHz oscillator circuit used in color TV reception. The oscillator is keyed on during the burst interval so it "looks" only at the burst signal on the original video signal. The signal then feeds both the burst keyer and a divide-by-455 circuit that has an output at 7.9 kHz (nominally). Next, the 7.9-kHz signal is used as a reference to phase-lock the 1.08-MHz clock oscillator. The 1.08-MHz oscillator is therefore phase coherent with the original video signal's color burst.

Note that the sync portion of the original video signal (if present) is simply discarded. Therefore it does not matter if the sync was noisy, missing, or at the wrong level. A new sync is generated and inserted.

#### Circuitry

Figure 3 is a detailed circuit schematic. Input video at J1 appears across termination resistor R1. If desired, R1 may be omitted for a 1K input impedance rather than 75 ohms. Resistor R2 controls the level of video signal fed to IC1, an LM733 differen-

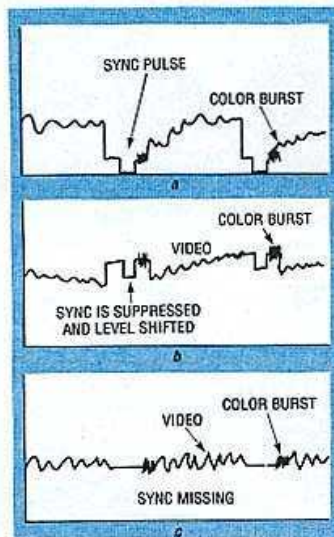

**FIG. 1—THE SYNC PULSES** are altered in either level or total amplitude, or omitted entirely from the video. The video may also be inverted. Sometimes the sync pulses may be suppressed to random levels, at different times.

ti-que, the video is inverted. If that's the case, you would see a picture, but the tones and colors would be re-

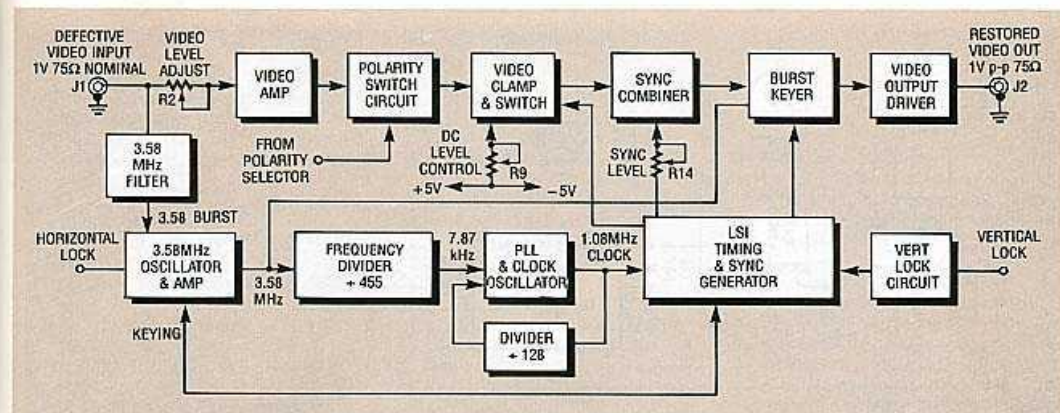

FIG. 2—HERE IS A BLOCK DIAGRAM of the sync regenerator. The circuit removes the "defective" sync and replaces it with a good one.

tial video amplifier, through coupling capacitor C1. R3 and R4 are bias resistors for IC1, which obtains DC power through decoupling networks R5, C2, and C3, and R6, C4, and C5; IC1 produces both an in-phase and a 180° out-of-phase signal at pins 8 and 9.

The two signals from IC1 are fed to a portion of IC2, a CD4053BE triple 2-channel analog multiplexer, which is used like an analog switch. The video polarity is controlled by the logic level at pin 10; S3 grounds pin 10 if reverse polarity is desired. R7 is a pull-up resistor for pin 10. The signal from the common pole of the switch is coupled through C6 to clamp-switch IC2-b and to switch IC2-c. During horizontal back-porch (black) periods, pin 3 of IC2-b and the negative side of C6 is clamped to a DC voltage determined by R9. Capacitors C11 and C12 form a bipolar bypass electrolytic. That sets the DC clamping level of the video signal.

During blanking intervals, the output at IC2-c pin 4 is switched from video to ground. Therefore, pin 4 has a ground level during blanking intervals and video during scan intervals. The original "defective" sync is not passed along. Instead, a new, ground-level blanking pedestal is inserted. Power-supply decoupling networks for IC2 are formed by C9, C10, and R12, together with R8, C7, and C8.

Video that has been stripped of its original sync at pin 4 of IC2-c is fed to pin 1 of IC3-a and on to the output of IC3-a at pin 15. During sync intervals, a -0.4-volt level (set by R14) is fed to pin 15. Therefore, the output

from IC3-a at pin 15 is a video signal with zero volts blanking level and -0.4-volt sync tips added. Resistor R13 and C13 are decoupling and bypass components.

All that's missing now is the 3.58-MHz color-burst signal. That is added through switch IC3-b. The burst signal comes from the oscillator and amplifier circuit to be discussed later via R45. The signal rise time to the control input of IC3-b is limited by R44, and R15 is a bias resistor. Components Q5, Q6, R16, C16, R17, and R18 form a unity-gain video driver. The output (corrected video) across R18 is fed to output jack J2.

In order to correctly perform all of the switching, timing signals are necessary. The 3.58-MHz components of the input video are picked off by filter C17 and L1 and fed to IC5 via R20, R21, and C18. When the horizontal-lock switch S1 is closed, Q1 is turned on, shorting the 3.58-MHz signal to ground. That function is used for both setup and establishing proper sync relations upon initial lockup. Since the oscillator initially cannot "know" which portion of the 3.58-MHz signal is the burst, pushbutton S1 is momentarily depressed. That causes the restored video image to roll horizontally on the video display. Switch S1 is held depressed until the image is correctly formed (centered). At that point, the sync relations are correct and the oscillator will lock up to correct phase. Actually, that will happen eventually anyway, since the only constant 3.58-MHz signal is the burst and, sooner or later, it will slip in and lock up. Once locked up, the circuit is

stable. A momentary loss of video may cause loss of lock in some instances. To correct that, depress S1 and reestablish lock.

Oscillator IC5 generates a 3.58-MHz signal that's phase-locked to the input signal. Components C19, R24, C21, and C22 form a loop filter, and C16, C27, and L3 are for power-supply decoupling. Crystal XTAL1, R25, C23, C24, and C25 form the oscillator circuit for IC5, and Q2, R26, R27, and R28 form a pulse-inverter circuit. The PLL circuit in IC5 is keyed on only during burst intervals; a burst-key pulse at pin 9 (produced by Q2) is used for that. Without that pulse, IC5 will not maintain a stable lock to the burst component from C18. Trimmer C24 adjusts the oscillator free-run frequency.

The 3.58 MHz CW signal, referenced to the burst from the input signal, is fed to amplifier Q3, and associated components (R30, R31, bypass-capacitor C29, R31, and L2—R32 is a bias resistor). Trimmer capacitor C32 and C30 tune L2 to 3.58 MHz; C32 is used to adjust the phase of the 3.58-MHz burst reference to compensate for tint (hue) variations, and C31 is a DC blocking capacitor. The 3.58-MHz signal (about 8–10 volts p-p) is fed to R34 and IC6. Components R34, R35, C41, and L4 form a network for coupling the 3.58-MHz signal through R45 to IC3-b, the burst keyer. Potentiometer R34 sets the burst level that appears on the corrected-video output at J2.

CMOS frequency divider IC6, along with diodes D1–D6, Q4, R36, R37, and C34, is used as a divide-

MAY 1990

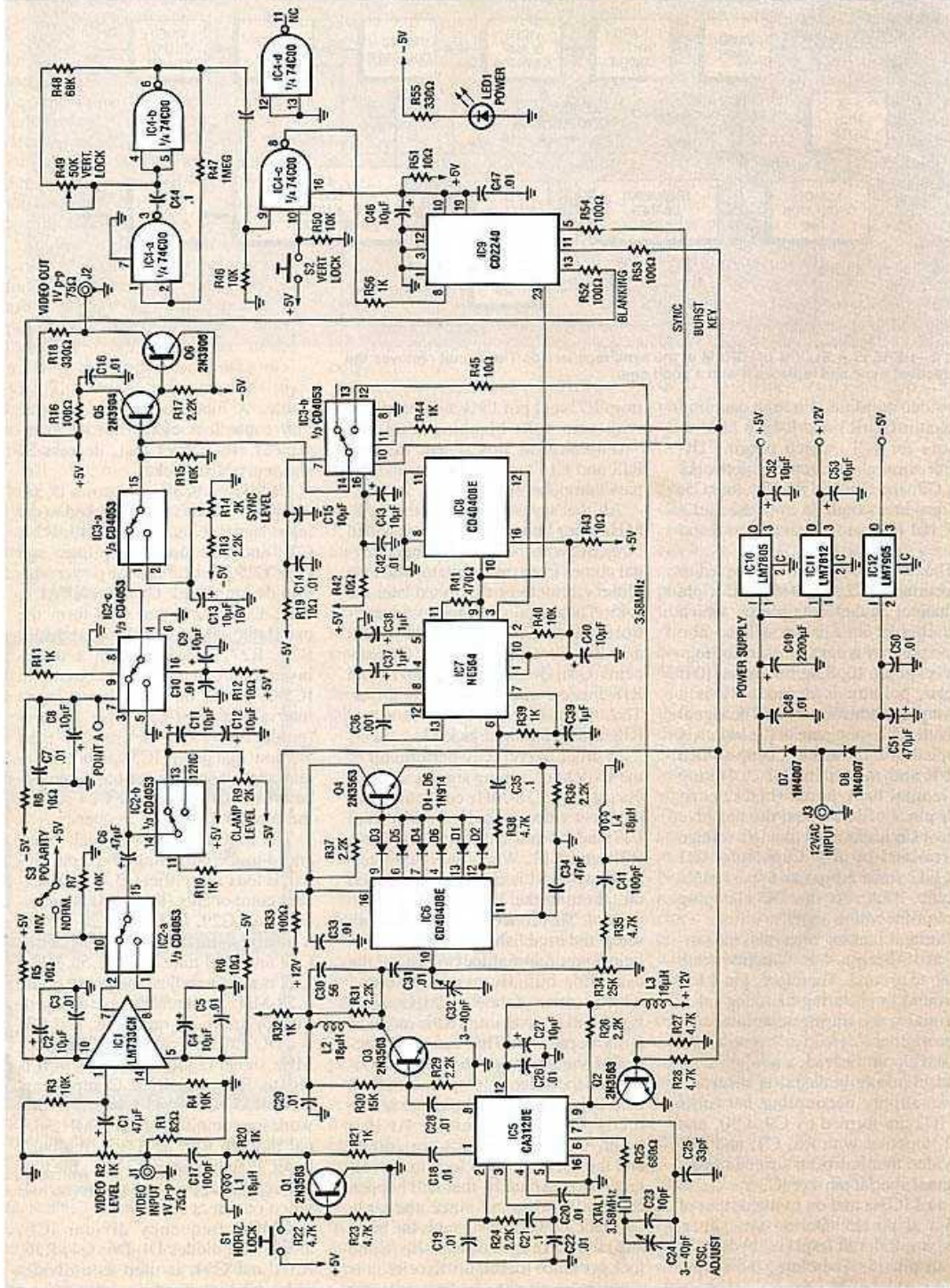

FIG. 3—SYNC REGENERATOR SCHEMATIC. "Defective" video is input at J1. It is then

## PARTS LIST

All resistors are 1/4-watt, 5%, unless otherwise noted.

R1—82 ohms  
 R2—1000 ohms, potentiometer with shaft  
 R3, R4, R7, R15, R40, R46, R50—10,000 ohms  
 R5, R6, R8, R12, R19, R42, R43, R45, R51—10 ohms  
 R9—2000 ohms, potentiometer with shaft  
 R10, R11, R20, R21, R32, R39, R44, R56—1000 ohms  
 R13, R17, R24, R26, R29, R31, R36, R37—2200 ohms  
 R14—2000 ohms, potentiometer  
 R16, R33, R52—R54—100 ohms  
 R18, R55—330 ohms  
 R22, R23, R27, R28, R35, R38—4700 ohms  
 R25—680 ohms  
 R30—15,000 ohms  
 R34—25,000 ohms, potentiometer  
 R41—470 ohms  
 R47—1 megohm  
 R48—68,000 ohms  
 R49—50,000 ohms, potentiometer

### Capacitors

C1, C6—47  $\mu$ F, 16 volts, electrolytic  
 C2, C4, C8, C9, C11—C13, C15, C27, C40, C43, C46, C52, C53—10  $\mu$ F, 16 volts, electrolytic  
 C3, C5, C7, C10, C14, C16,

C18—C20, C22, C26, C28, C29, C31, C33, C42, C45, C47, C48, C50—0.01  $\mu$ F, ceramic disc  
 C17, C41—100 pF, NPO  
 C21, C35, C44—0.1  $\mu$ F, Mylar  
 C23—10 pF, NPO  
 C24, C32—3—40 pF, trimmer  
 C25—33 pF, NPO  
 C30—56 pF, NPO  
 C39—47 pF, NPO  
 C36—0.001  $\mu$ F, Mylar  
 C37—C39—1  $\mu$ F, 50 volts, electrolytic  
 C49—2200  $\mu$ F, 16 or 25 volts, electrolytic  
 C51—470  $\mu$ F, 16 or 25 volts, electrolytic

### Semiconductors

IC1—LM733CN differential video amplifier  
 IC2, IC3—CD4053BE triple 2-channel analog multiplexer  
 IC4—74C00N quad 2-input NAND gate  
 IC5—CA3126E TV chroma processor  
 IC6, IC8—CD4040BE ripple carry binary counter/divider  
 IC7—NE564N—phase-locked loop  
 IC9—CD2240 CMOS LSI video sync generator  
 IC10—LM7805 +5-volt regulator  
 IC11—LM7812 +12-volt regulator  
 IC12—LM7905 -5-volt regulator  
 D1—D6—1N914B small signal diode  
 D7, D8—1N4007 rectifier diode  
 LED1—light-emitting diode, any color

D7, D8—1N4007 rectifier diode  
 LED1—light-emitting diode, any color

### Other components

L1—L4—18  $\mu$ H choke  
 XTAL1—3.58 MHz crystal, 0.005%, 32 pF, fundamental mode, parallel resonant  
 J1, J2—RCA-type phono jack  
 J3—2.5 mm power jack  
 S1, S2—N.O. pushbutton switch  
 S3—SPST toggle switch

**Miscellaneous:** cabinet (Radio Shack # 270-272A is perfectly suited), hardware as required, IC sockets (if desired), 12-volt AC, 350 mA wall transformer or other power transformer (see text)

**Note:** A complete parts kit, including the PC board, switches, potentiometers, jacks and plugs, and all parts that mount on the PC board is available from North Country Radio, P.O. Box 53, WYKAGY! Station, NY 10804. Price for the kit is \$92.50 + \$2.50 shipping and handling. A wall transformer is available for \$8.75 extra when ordered with the kit. A partial kit consisting of only the PC board and IC1 through IC12 is available for \$72.50 + \$2.50 shipping and handling. Case is not included in either kit.

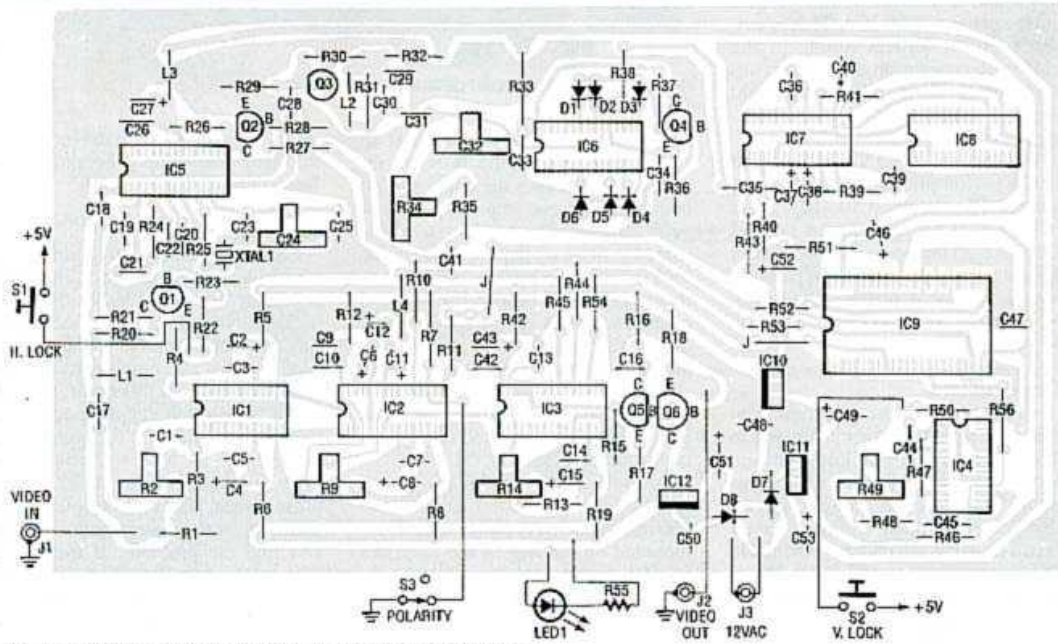

FIG. 4—PARTS-PLACEMENT DIAGRAM for the sync regenerator.

MAY 1990

by-455 circuit. That results in a 7.87-kHz signal at pin 12 of IC6; the signal is coupled via R38 and C35 to IC7, an NE564 phase-locked loop frequency multiplier that operates at about 1.08 MHz. Capacitor C36 determines the initial frequency, and C37 and C38 determine loop characteristics. The 1-MHz VCO output from IC2 is fed to IC8, a CD4040 CMOS binary counter, that divides by 128 and feeds the nominal 7.87-kHz result back to the phase detector of IC7. That produces a lock condition and the 1.08-MHz signal from IC7 is phase-locked to the 7.87 kHz input signal. Resistor R40 sets the gain of PLL IC7, C40 and C37 are bypass capacitors, and R43 is a supply decoupling resistor.

The 1.08-MHz clock signal is fed to video sync generator IC9 that produces requisite timing signals from that clock signal. IC9 supplies burst-keying, blanking, and sync signals to analog switches IC2 and IC3, and also to Q2. Resistors R52, R53, and R54 provide short-circuit protection as well as test points for those signals. R51, C46, and C47 are power-supply decoupling components.

Even if horizontal locking is correct in phase, vertical locking may not be, so IC9 must be locked up by pulses from lock-oscillator circuit IC4. Pressing S2 enables pulses from IC4-a and -b to synchronize vertical pulses generated by IC9. That is evidenced by a vertical rolling of the video image seen on a monitor connected to J2. Switch S2 must be held depressed until vertical lockup (framing) is correct.

DC power (-5V, +5V, and +12V) is supplied to all IC's, as required. Regulators IC10, IC11, and IC12, C48-C53, and diodes D7 and D8 make up the power supply. About 12-volts AC at 350 mA is required at power-jack J3. A power-on indicator is formed by R55 and LED1, and may be omitted, if desired.

#### Construction

A PC board is the preferred construction technique for this project to keep stray-signal pickup, ground loops, or other glitches to a minimum. Therefore we strongly suggest that you either make a printed-circuit board from the foil pattern provided in PC Service, or use a PC board from the source mentioned in the parts list. A parts-placement diagram is shown in Fig. 4.

Begin assembly by first installing all fixed resistors. Next, install the diodes, the four chokes, then the capacitors. Then install the five potentiometers. The two potentiometers R2 and R9 should be fitted with shafts, as they are front-panel controls. The use of sockets for all IC's is recommended, though not essential; that makes testing easier. Do not install any IC's until the last components are installed on the board.

Switches S1-S3, J1-J3, and LED1

the case along with the PC board if preferred. If you exceed 14-volts AC, the voltage regulators (IC10-IC12) may run too warm as they are not heat sinked. C49 and C51 should be increased to 25-volt ratings and IC10-IC12 should be heat sinked if more than 14-volts AC is used.

A DC power source cannot be used, since we use both positive and negative half cycles of an AC waveform to derive the +12-, +5-, and -5-volt DC supplies. A power

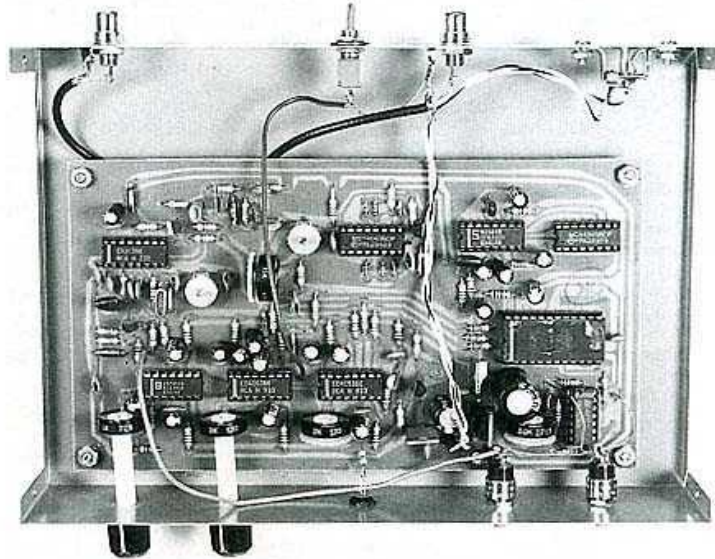

FIG. 5—HERE IS THE COMPLETED prototype unit.

can be wired to the PC board after all components except the IC's are installed. That allows the entire unit to be installed in one step in the case of your choice. The project was designed to fit a case that's 8 inches wide by 6 inches deep by 2 inches high, or thereabouts. It's best to use a metal case; other cases can be used—wood or plastic is OK—but stray-signal pickup can occur due to the lack of shielding. The prototype was built in Radio Shack's # 270-272A. The board should be mounted on four 1/2-inch standoffs (see Fig. 5).

A power source can be any 12-volt AC, 60-Hz wall transformer of at least 350 mA capacity. A power jack (J3) is mounted on the rear of the case, but you can hardwire the power pack directly to the board—J3 is therefore optional. A 12-volt AC general-purpose transformer can be mounted in

switch was not used on the prototype; the plug can simply be pulled out from J3 to turn the unit off.

#### Checkout

Carefully inspect all connections for correct soldering. Next, check for any inadvertent solder bridges especially around the IC pins. Make sure correct components have been used and that all components are correctly oriented. At this point, without the IC's inserted, apply power and immediately measure the voltages on the +5-, -5-, and +12-volt buses. They should be within  $\pm 0.25$  volts of those values. If any of the voltages are incorrect, immediately remove power and find the problem. If everything seems OK, keep the PC powered for several minutes; nothing should get hot or smoke. If it does, locate and correct the problem.

When the power-supply section is working, check for the following voltages ( $\pm 10\%$  unless otherwise noted) before inserting the IC's.

- IC1 pin 5: +5V
- IC1 pin 10: -5V
- IC2 and IC3 pin 7: -5V
- IC2 and IC3 pin 16: +5V
- IC5 pin 12: +12V
- IC6 pin 16: +12V
- Collector of Q2: +12V
- Collector of Q3: +4 to +8V
- Emitter of Q5: -0.6V
- Emitter of Q6: 0V  $\pm 0.3$ V
- IC7 pins 1 and 10: +5V
- IC8 pin 16: +5V
- IC9 pins 10 and 19: +5V
- IC4 pin 16: +5V
- IC2 pin 13: +5 to -5V (should vary with setting of R9)
- IC2 pin 2: 0 to -2.2V (should vary with setting of R14, adjust R14 for -0.45V)

Remove power from J3 and insert all IC's in the board. Next, set all trimmer potentiometers and capacitors at midpoint except R14, which was initially set during checkout. Now apply power to the board and quickly check for the following voltages. Note that the voltages can vary by as much as 20%.

- IC1 pins 7 and 8: +1.5 to +3.0V
- IC5 pin 9: -0.2V
- IC9 pin 13: +3.6V
- IC9 pin 11: +4.1V
- IC9 pin 5: +4.6V
- IC2 pin 9: +3.6V
- IC2 pin 10: +4.9V
- IC2 pin 11: +4.1V
- IC3 pin 10: +4.6V
- IC3 pin 11: +4.1V
- IC4 pin 6: +2.5V

### Testing and using

Hook up the unit as shown in Fig. 6. Connect a video monitor to J2. If no such device is available, you can use an ordinary TV tuned to CH3 or CH4 with an RF modulator connected as shown in Fig. 6. Rotate R9; there should be a blank raster on the screen, white, gray, or black, adjustable with R9. Figure 7 shows what the waveform at J2 should look like on an oscilloscope at this point.

Now apply a video signal to J1. Adjust R2 and then R9 for a visible image as shown in Fig. 8. It may roll, but that's normal. Set R9 for barely visible white clipping, and then back off a bit. Adjust R2 for proper contrast. Next, depress vertical-lock switch S2. A bar should roll visibly

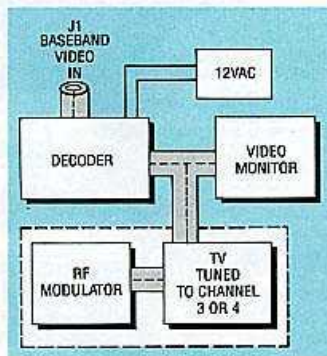

FIG. 6—HOOK UP THE UNIT as shown here. The unit requires a baseband-video input, and it outputs baseband video. If you don't have a baseband video source, then you need something like a VCR with an RF input and a baseband-video output jack. If you don't have a monitor that accepts baseband video, then you need an RF modulator or a VCR with a baseband-video input jack and an RF output.

up and down. Adjust R49 for a slow roll. By "tapping" S2 you should be able to lock the picture vertically. Set S3 to positive polarity (open). Now depress S1, the horizontal-lock switch. The picture should roll horizontally and possibly vertically, as well. Adjust trimmer-capacitor C24 until the roll is slow. By "tapping" S1 you should be able to lock in the image horizontally.

Adjust R2 and R9 for a good image. Misadjustment of R9 will either wash out the picture or cause horizontal tearing and loss of lock. Actually,

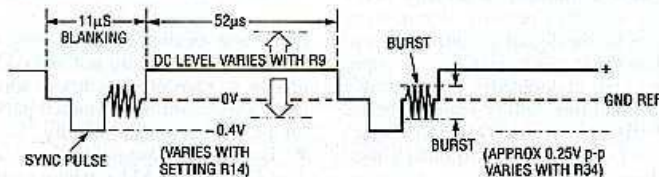

FIG. 7—THE WAVEFORM AT J2 should look like this when the circuit is powered up with no video input to J1.

you can deliberately scramble a picture by adjusting R9 so that the new sync pulses are suppressed with respect to the video. Toggle-switch S3 should invert the video yielding a negative picture.

If the resultant image has weak color, adjust the burst-level control R34. Tint shifts can be adjusted with C32, if necessary. Instability in the color of the received picture normally

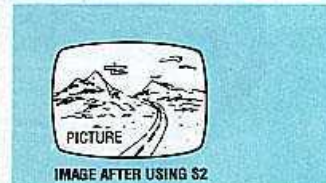
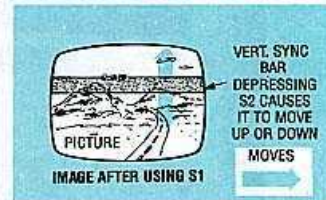
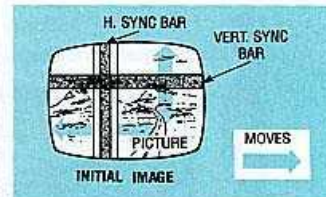

FIG. 8—AFTER APPLYING A SIGNAL TO J1, adjust R2 and R9 for a visible image as shown here; it may roll, but that's normal.

indicates incorrect lockup. Tap S1 (horizontal lock) to correct the problem. S3 can be used to change video polarity, but that will normally require a slight readjustment of R9 to correctly set the DC levels.

In case you have any difficulty in getting the decoder working, first check for a 1-volt p-p video signal at J1. It is assumed that +5, -5, and +12 volts are present. Next check to

see that IC5 is producing a 3.58-MHz signal. Also check for about 8-12 volts p-p at 3.58 MHz at pin 10 of IC6. Check for a 7.8-kHz pulse train at pin 12 of IC6. Check for a 1.08-MHz clock signal at pin 23 of IC9. Those are just a few troubleshooting tips in case you have any problems. However, you shouldn't experience any problems if your workmanship is good.

SECRET

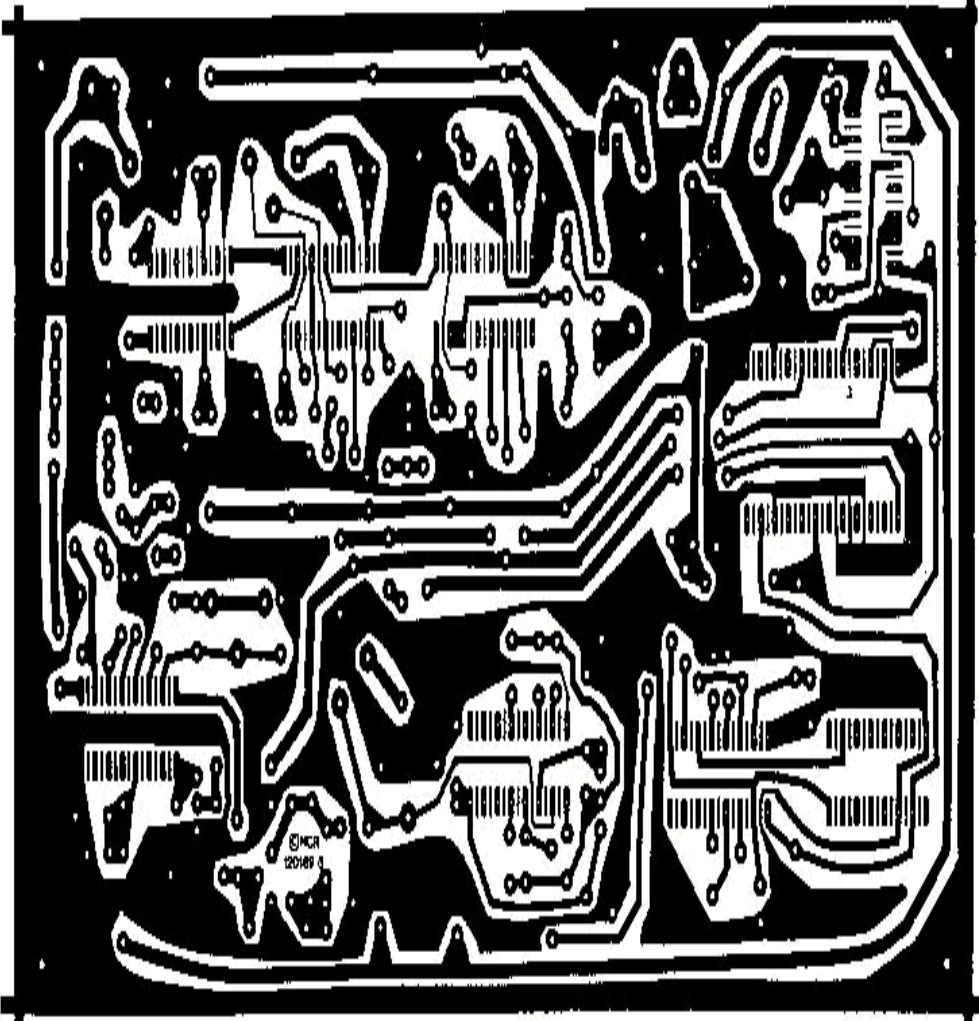

7 INCHES

UNIVERSAL DESCRAMBLER FOIL PATTERN. It's a single-sided board.



## Errata, Hints & Kinks - Universal Descrambler

1. Some Electrolytics capacitors supplied with the kit may be higher in voltage than those specified in the parts list. This is OK and normal.
2. The PC board supplied # 902 should be used as a reference to resolve any schematic discrepancies. It works and has been thoroughly tested. The original article had several discrepancies in the parts list and schematic. We have eliminate any that we have found.
3. Don't use the parts placement diagram on page 41 of the article. We have supplied our own parts placement diagram that is the same as our Silk-Screened pc board. The pc board we designed for the universal circuit is somewhat different, but not much from the published version. This was done to allow us to silk-screen the pc board and make it easier to construct and troubleshoot. Our pc board is solder-masked( thats the green stuff ) reducing the chance of having a solder bridge during construction.
4. The figures shown are the diode (CR-1 thru CR-8) installation infromation for proper placement. Think of it as the arrow pointing to the cathode end.

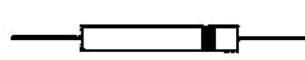

Colored band is Cathode



Vertical bar is the Cathode

5. The AC Adaptor supplied with the kit may vary from time to time and have addition instructions. However, every adaptor is tested in circuit prior to being approved for use with the universal kit.  
If you use your own adaptor make sure that the voltaged supplied across C-49 is at least 14 volts DC and no more than 16 volts DC. If you do exceed 16 volts DC across C-49, then C-49 and C-51 should be changed to a 25 volt DC rating.
7. C-24 & C-32 Trimmer Capacitors come in two versions, 7.5mm and 10 mm. The 10mm trimmer capacitor is somewhat larger and will require you to bend two of the leads to fit.
8. We reserve the right to modify and or change the parts specifications as we see fit. However, you can be assured that all changes will be thoroughly tested prior to being approved for use with the univernal project.
9. Some video sources are deficient in high frequency response. This can cause low levels of 3.58Mhz burst signal at J1 and subsequent locking difficulties with IC-5 (U5). If you are having trouble getting horizontal lock, check the 3.58Mhz burst level that is contained within the horizontal blanking period. This has to be check with an oscilloscope set at the 50 us time base. Since both the horizontal and vertical is derived from this 3.58Mhz burst signal, both would have to fail to lock if the 3.58Mhz was low. If only the vertical failed to lock and continued to roll, you would check IC-4 (U4) circuit for proper operation.
10. If the video level output is too high, insert a 68 ohm resistor between R-18 and Q-6 emitter ( in series ) and take the video output from the junction of R-18 and the 68 ohm resistor. The 68 ohm resistor not included.  
IC-5 (U5) pin 9 normally reads +.2 to +.3 volts and not -.2 volts. IC-1 (U1) pins 5 and 10 are -5 and + 5 respectively. both were incorrect as in RE page 43 col. 1.

12. IC-10 (U10) may run somewhat hot if you apply more than 16 Volts AC to J-3 without providing a heatsink. Install heatsinks or lower the voltage by adding two series resistors to the input to J-3. The circuit draws about 228ma, use ohms law to calculate the series resistor that would drop the voltage. Example for lower the voltage from 18 to 16,  $V/I=R$ ,  $V=2\text{ volts}/I=.228\text{ ma} = 8.7\text{ ohms } 1/2\text{ watt resistor}$ .

13. Ringing on picture-Check IC-1 (U1) - Make sure C2, C3, C4 and C5 are installed or try a bypass capacitor .01uf between IC-1 (U1) and ground (across R4).

14. Incorrect hue can be improve by adding a capacitor across C32, try a 33pf. If this makes things worse remove the capacitor across C32 and then try changing C30 from a 56pf to a 33pf. If it don't improve? Return the circuit to normal and look for a circuit problem.

15. Color stability is a function of an accurate lockup. Try resetting lock with S-1. If this does not help make sure the video signal is clean. Some experimenters have reported that IC-6 (U6) can produce "glitches". Changing the value of R36 to a 1K and C36 to a 820pf or .0015uf has helped in these cases.

16. Video smear may be caused by an incorrect frequency response somewhere in the video system. This is generally an interface problem. Try the follow if you have a smear problem.

a. Remove IC-2 (U2) and IC-3 (U3).

b. Connect jumpers wires as follows:

1. IC-2a (U2) pin 2 to pin 15.
2. IC-2c (U2) pin 3 to IC-3a (U3) pin 15.

c. Using a good non-scrambled video signal into J1 and examine the video at J2. If OK, the problem is not the circuit.

d. Restore the circuit to its original condition by removing the jumpers and install IC-2 & IC-3. Apply video as in step c. and check out the video at J2. If it's still OK, then the source you are using is bad. A typical case it that the non-scrambled signal is OK, but a scrambled signal causes smearing, blotchy color or shading.

17. A VCR, TV tuner or video source that you are using may not work properly on a scrambled signal. Your equipment may contain circuitry that depends on the missing sync pulses of a scrambled signal to operate the AGC or DC restoration circuitry.

18. Your unit must pass the test on page 43 RE if there is any hope of it working at all.

19. Expect good results, but not perfection. This unit works well in most systems, but was designed as a universal type and not for a specific system. You cannot expect the performance of a descrambler designed for a dedicated system, but it can come very close. Overall, it is a good performer within it's design and cost factors, and should prove very useful in many applications.

20. Remember we are not the authors of this article and can not offer much in the way of technical help. However, the original authors have published a **Technical HOT Line** 1:30 pm to 4:30 pm, eastern standard time Monday thru Friday.

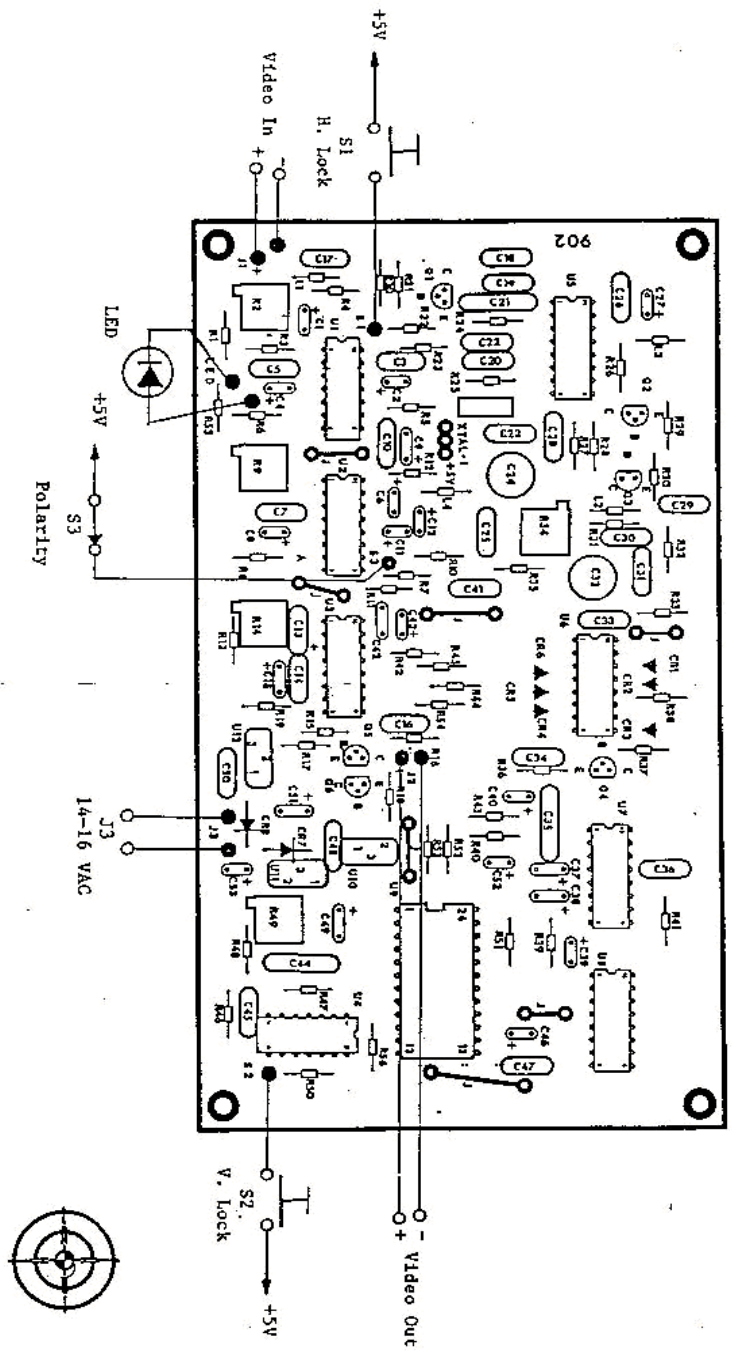

Parts placement for the Universal Project. Note: the +5 volts for S1, S2 and S3 can be taken off the PC board below the XTAL-1 marking. We have provided three holes for the +5V.