

HP 35687B Operator's Guide

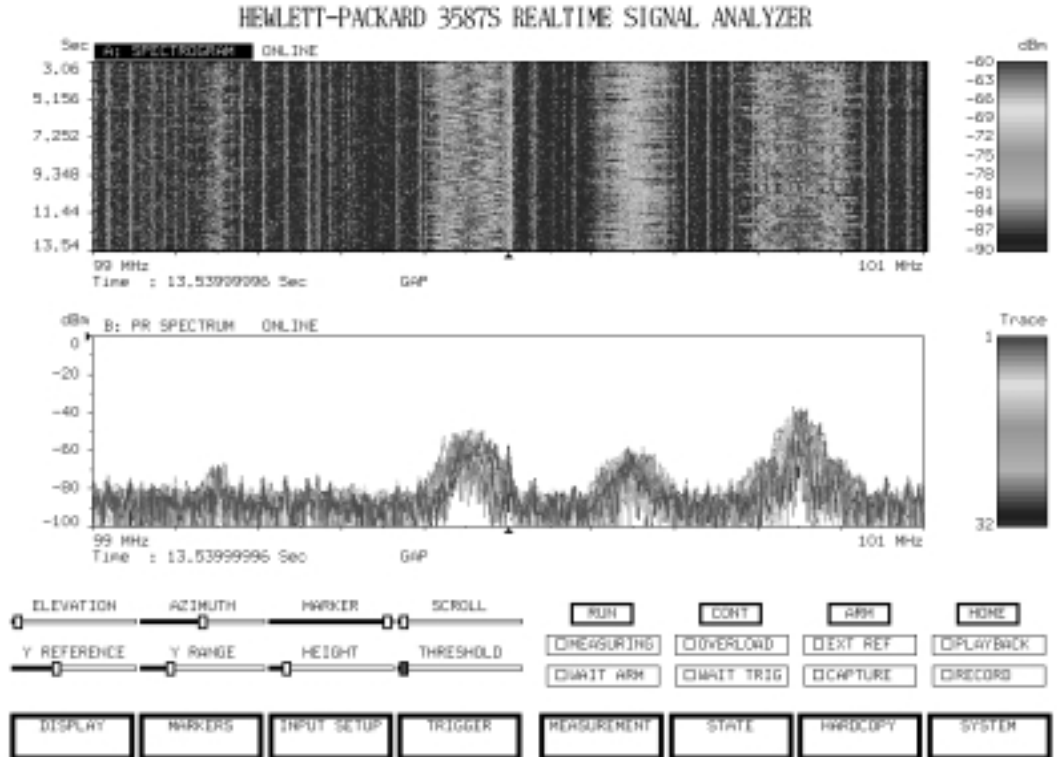

HP Part Number: 35687-90032
Software Version: B.03.06+

Printed in U.S.A.
Print Date: August 1998

© Hewlett-Packard Company, 1995-1998. All rights reserved.
8600 Soper Hill Road Everett, Washington 98205-1298 U.S.A.

NOTICE

The information contained in this document is subject to change without notice.

HEWLETT-PACKARD MAKES NO WARRANTY OF ANY KIND WITH REGARD TO THIS MANUAL, INCLUDING, BUT NOT LIMITED TO, THE IMPLIED WARRANTIES OF MERCHANTABILITY AND FITNESS FOR A PARTICULAR PURPOSE.

Hewlett-Packard shall not be liable for errors contained herein or direct, indirect, special, incidental or consequential damages in connection with the furnishing, performance, or use of this material.

Warranty

A copy of the specific warranty terms applicable to your Hewlett-Packard product and replacement parts can be obtained from your local Sales and Service Office.

Restricted Rights Legend

Use, duplication, or disclosure is subject to HP standard commercial license terms or to the following restrictions, whichever is applicable:

For non-DoD Departments and Agencies of the U.S. Government, as set forth in FAR 52.227-19(c)(1-2)(Jun 1987);

For the DoD and its Agencies, as set forth in DFARS 252.227-7013 (c) (1) (ii) (Oct 1988), or DFARS 252.221-7015(c) (May 1991), whichever is applicable.

HEWLETT-PACKARD COMPANY
3000 Hanover St.
Palo Alto, CA 94304

©Copyright 1997 Hewlett-Packard Company. All rights Reserved

This document contains proprietary information which is protected by copyright. All rights are reserved. No part of this document may be photocopied, reproduced or translated to another language without the prior written consent of Hewlett-Packard Company. The information contained in this document is subject to change without notice.

Use of this manual and flexible disk(s) or tape cartridge(s) supplied for this pack is restricted to this product only. Additional copies of the programs can be made for security and back-up purposes only. Resale of the software in its present form or with alterations is expressly prohibited.

Printing History

Edition 1 - December 1995

Edition 2 - May 1997

Edition 2 - May 1998

Table of Contents

Introduction	1
Guide to Documentation	3
Using Peripheral Controls.	4
Window and Keyboard Controls	5
Options & Accessories	6
Notations & Conventions	7
In This Book	8
Getting Started.	9
System Configuration	10
Hardware Installation.	10
System Configuration Files.	13
Starting and Stopping the System	14
Working With the Display	17
Introduction	18
On-Line Help	20
Playing a Stored Record	22
Spectrum Display	23
Y-Axis Scale	24
X-Axis Scale	26
Using the Marker	27
Rollogram Display	28
Digital Persistence Display	29
Spectrogram Display	30
Color Map Display	32
Map Colors	34
Map Color Scaling	36
Image Enhancement	38
Convolution Filtering.	38
Median Filtering	39
Spectral Map	40
Active Trace	42
Strip Chart	44
Strip Chart Markers	46
Histogram, PDF, and CDF	48
Titles and Annotation	50
Printing	52
Batch Printing.	54



Making Measurements	55
Introduction	56
Presetting the System	57
Online Measurements	58
Input Range	60
Frequency Span	61
Window Functions	62
Measurement Resolution	64
Overlap Processing	66
Zoom Measurements	68
Y-Axis Coordinates	70
Complex Coordinates	72
Averaging	74
Trigger Conditions	76
Trigger Modes	77
Other Trigger Functions	78
Collecting Data	79
Introduction	80
Collection Methods	81
Signal Capture Data	81
Throughput Capture Data (option ATR)	81
Display Data	82
File Systems & Data Formats	83
Signal Capture	84
Analysis	85
Background	85
Playing Back Captured Data	86
Throughput Capture (option ATR)	87
Post-Processing Capture Data (option ATR)	88
Extracting Data From Capture Files (option ATR)	90
Archiving and Restoring Capture Files	91
Saving and Recalling Display Data	93
Recording and Playing Back Display Data	94
Saving a Single Trace	95
Displaying State Information	96
Saving and Recalling Instrument State	98
Checking System Disk Space	99
Memory Usage	100
Copying Saved Display Data	102
Copying Saved Signal Capture Data	103
Deleting a File	104
Appendix A: Keyboard User's Guide	105
Button Box Functions	106
Knob Box Functions	107
Keyboard Accelerator Keys	108
Appendix B: Display and Measurement Cross-Reference	109
Display Type vs Changeable Display Parameters	110
Setup Parameters Which Affect Measurement Results	112
Appendix C: Preset Parameters	113
Appendix D: Image Enhancement Convolution Kernels	117
Glossary	119
Index	123

Introduction

This chapter discusses the following topics:

- System documentation
- Using Peripheral Controls
- Window and Keyboard Controls
- Options and Accessories
- Notations and Conventions
- Contents of this book

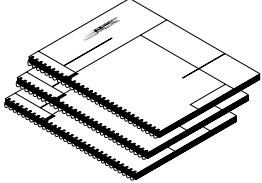
Guide to Documentation

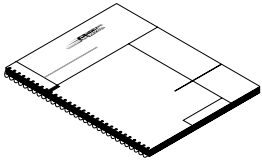
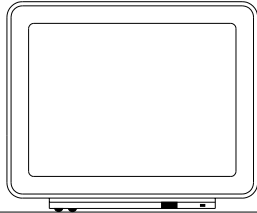
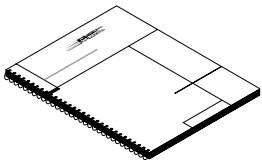
If you want to:	Read:	
<ul style="list-style-type: none"> ● Unpack the HP 3587S Realtime Signal Analyzer ● Perform incoming inspection (operation verification and performance tests), ● Find general service information such as troubleshooting. 	<p>C-Size VXIbus Systems HP E1437A VXI ADC Operator's Guide HP E1485C VXI Signal Processor Installation and Service Guide HP E3249 System Disk Documentation HP E1562 Throughput Disk Documentation HP E1498 (V743) System Controller HP 3587S Hardware Installation Note</p>	
<p>Install or upgrade the HP 35687B Software in your HP-UX workstation.</p>	<p>HP 35687B Installation Note</p>	
<p>Make system connections, turn on the HP 3587S Get comfortable with the HP 3587S</p> <ul style="list-style-type: none"> ● Configure hardware (page 10) ● Change the display (page 17) ● Make measurements (page 55) ● Capture and /or [playback data (page 79) 	<p>HP 35687B Operator's Reference HP 3587S Hardware Installation Note</p>	
<p>Learn what each key does</p>	<p>HP 35687B Online Help System See page 20.</p>	
<p>Learn how to:</p> <ul style="list-style-type: none"> ● customize controls and colors ● create macros ● create display and marker functions ● implement automated control ● set up printers ● use a downconverter ● define time-capture file headers ● define regular-file data headers 	<p>HP 35687B Option AGG Customization and Programming Reference. (This book is part of option AGG.)</p>	

Note

With this release, HP-UX 9.0x is no longer supported. To upgrade your HP 3587S system to HP-UX 10.20, please contact your local Hewlett-Packard sales office.

Using Peripheral Controls

The following figures illustrate the mouse, button box, and knob box peripheral controls. See System Configuration on page 10 for information about how to connect the system pieces. See Appendix A on page 105 for detailed information about the functionality of the button and knob-box controls.

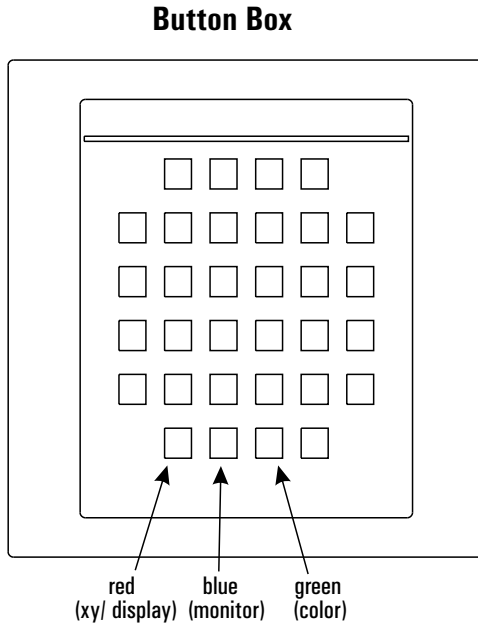
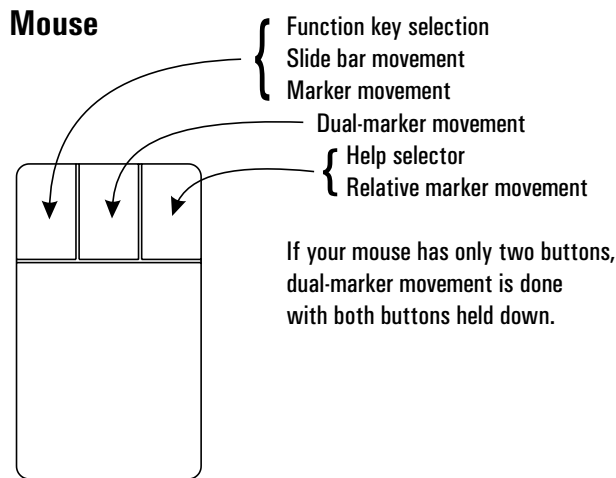

These buttons select one of three possible functions for the knobs on the knob box.

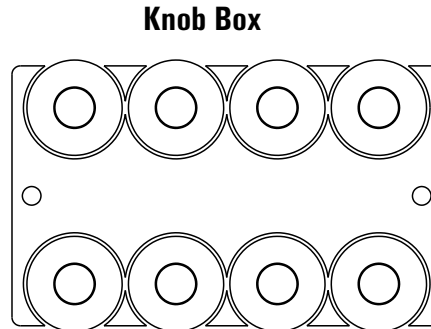

The knob box offers an alternative to using the mouse to move sliders in the GUI window. The parameters controlled with the knobs or sliders are grouped into three categories:

1. X/Y display (elevation, azimuth, marker, scroll, Y ref, Y range, etc.)
2. Monitor (span freq, center freq, resolution, input range, etc.)
3. Color (color map, # colors, trace color, grid color, etc.)

You select one of these parameter groups by pressing a button on the button box. The groups are also designated by colors. As you turn a knob, the corresponding slide bar moves to show the changing value within the range.

Window and Keyboard Controls

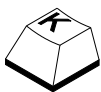
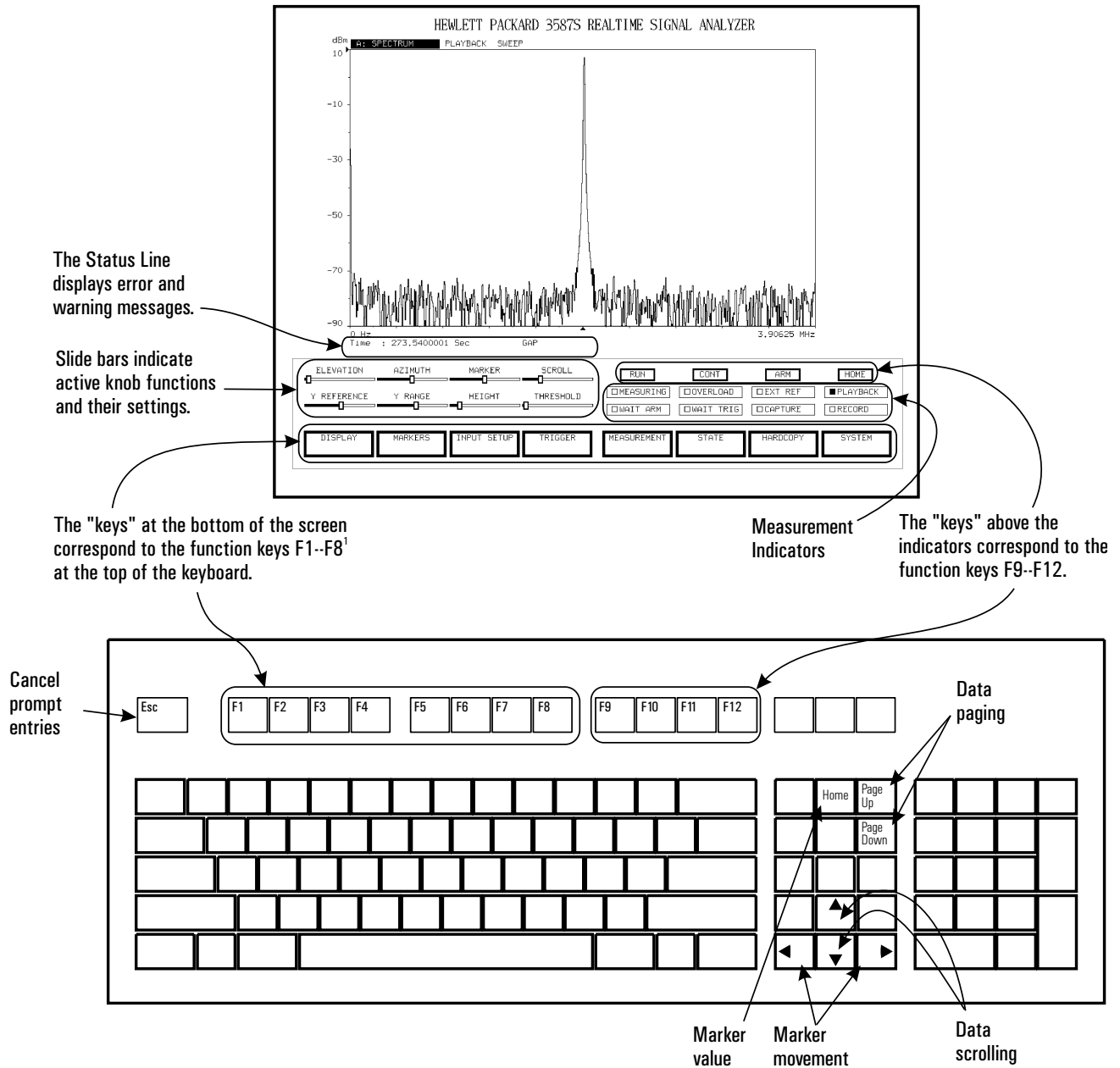

1. The key icon used in tutorial steps refers to using this keyboard (especially the function keys) or using the mouse to click on the softkey equivalent at the bottom of the display area.

Options & Accessories

HP 35687B Option AGG Customization Software

This option lets you optimize the HP 3587S Realtime Signal Analyzer for your needs using HP-UX. You can customize the functionality of the knob box, button box, menu system, and keyboard accelerators. You can also create your own functions and macros, and make the HP 3587S compatible with other printers.

This option is documented in the *Customization and Programming Reference*.

The HP-UX workstation should include the C development environment.

HP 35687B Option ATR Throughput Disk Capture

This option adds one or more E1562 VXI hard disk modules to support capturing the digitized signals created by the ADC module as Standard Data Format (SDF) files. These files can be processed as any “live” signal might be and the files can be moved to other systems for further analysis.

This option is documented under Collecting Data in this manual.

Notations & Conventions

As you work through each exercise, refer to the icon in the left margin which shows where the given function(s) are located. Each icon stands for the following.

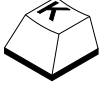

1. Function is located on the computer keyboard. The keyboard function keys have corresponding buttons at the bottom of the screen which you can click with the mouse.



2. Use the computer mouse to perform the task



3. Function is located on the knob box

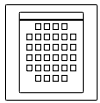

4. Function is located on the button box

If you do not have a knob box or button box, refer to Appendix A which locates each knob/button box function in the softkey menu structure.

To locate keys in the menu structure, use [HOME] [SYSTEM] [HELP INDEX].

In This Book

This book introduces you to the HP 3587S Realtime Signal Analyzer. The introduction comes in the form of several quick tasks that will have you making measurements in no time.

The manual contains four sections:

Getting Started describes how to setup up the hardware. For more detail on this subject, see the Hardware Installation Note.

Working With the Display describes several ways to display data and how to print the display.

Making Measurements describes how to make several basic measurements.

Collecting Data describes how to collect, retrieve, and post-process data. This covers using option ATR, Throughput Disk Capture.

If you prefer using the computer keyboard to access controls, a *Keyboard User's Guide* is given in Appendix A which shows how to access each knob/button box function using the keyboard or use the Help Index. If you need additional information while you are performing one of these tasks, use the analyzer's on-line help system—see page 20.

Getting Started

This chapter shows how to install the VXI modules and connect the peripheral components together to configure the HP 3587S. More detail is provided in the HP 3587S/E3238S Hardware Installation Note.

System Configuration

There are two requirements to properly configure a system

The hardware components must be installed and cabled properly.

The configuration must also be “documented” in one or more configuration files.

Hardware Installation

The basic system is composed of:

- System controller (E1498A VXI)
- System disk (SCSI; may be VXI or not)
- ADC (either a E1430A [4 MHz BW] or a E1437A [8 MHz BW])
- DSP (E1485C)

Optional modules:

Tuner

- HP 89431A (non-VXI; 2-2,650 MHz)
- WJ-9119 (VXI; 0.5-32 MHz, 4 MHz BW, use with E1430A)
- WJ-9119-1 (VXI; 0.5-32 MHz, 8 MHz BW, use with E1437A)
- HP E6500 (VXI; 1 GHz or 3 GHz)
- CS-5040 (VXI; 18 GHz, 40 GHz, or 60 GHz)

Throughput disks

- E1562E (VXI SCSI controller and disks)
- E1562F (VXI SCSI disks)

The following steps describe how to assemble the system hardware:

1. See the “HP 3587S/E3238S Hardware Installation Note” for instruction on setting module switches and installing the VXI modules in the mainframe.
2. Refer to the following figures and make the following connections:
 - Connect the keyboard to PS/2 0 on the E1498A
 - Connect the mouse to PS/2 1 on the E1498A
 - Connect the button box to RS-232 (A) on the E1498A
 - Connect the knob box to the button box with the C2932A daisy chain cable
3. Connect the monitor to the Video output connector on the controller.
4. Connect the E3249B system disk drive to the SCSI input on the controller.
5. Turn on the mainframe. Check that the light next to the switch turns on.
6. Turn on the monitor. Check that the light next to the switch turns on.
7. Place the appropriate overlays on the button box, knob box, and numeric keypad.

To install the optional downconverter or option ATR (throughput disk capture), see the “HP 3587S Hardware Installation Note” for more information.

The following illustrations show various combinations of optional VXI modules.

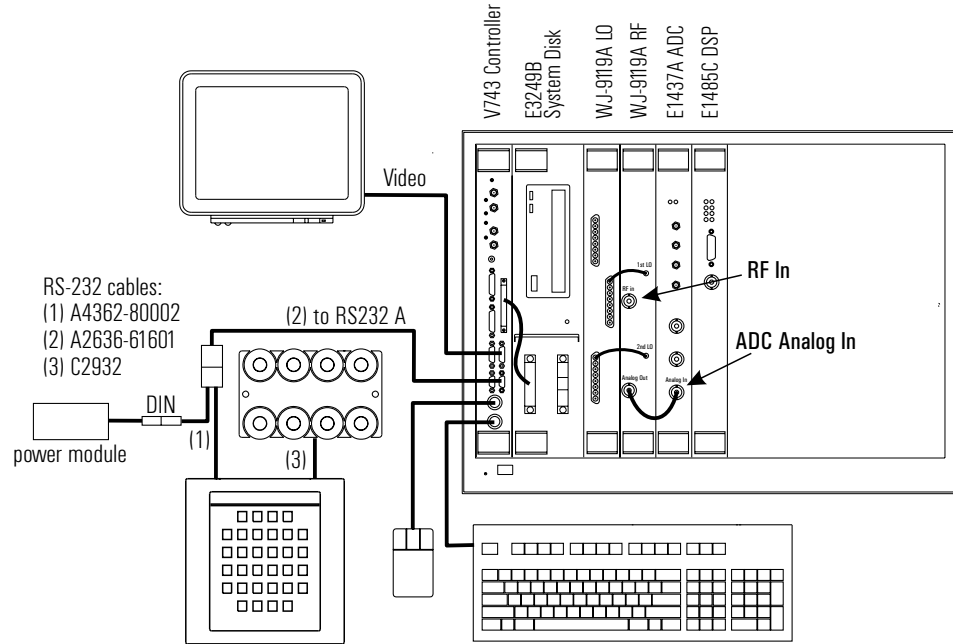

HP 3587S System with optional WJ9119 HF tuner.

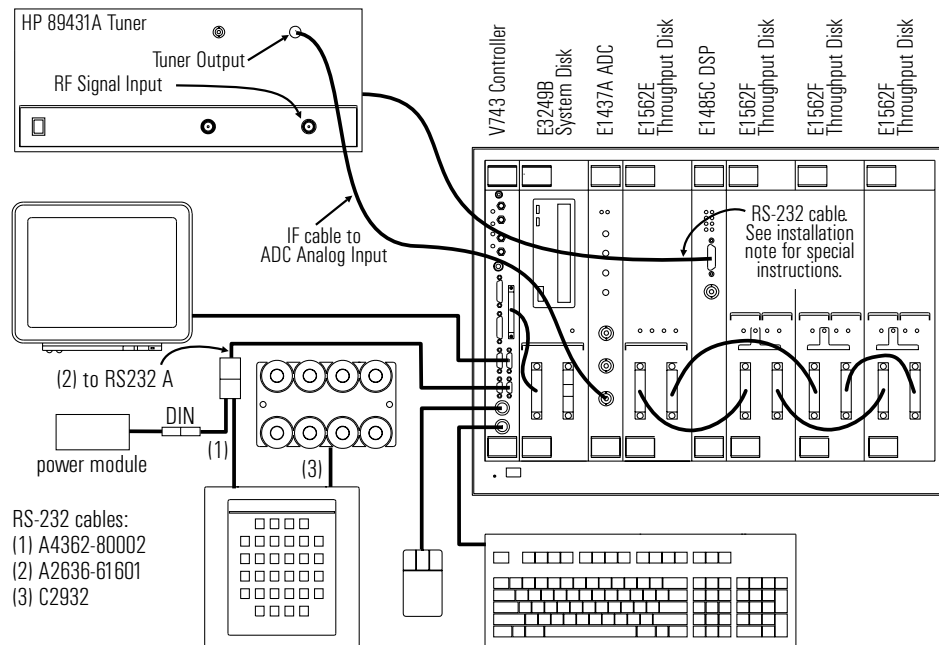

HP 3587S System with optional VHF/UHF tuner and option ATR, throughput disk capture.

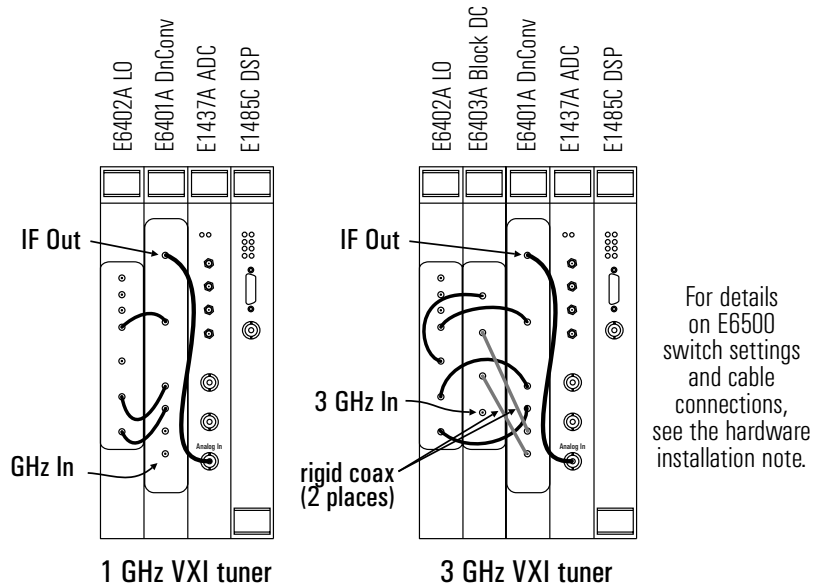

The E6500 3 GHz tuner uses an additional block downconverter module.

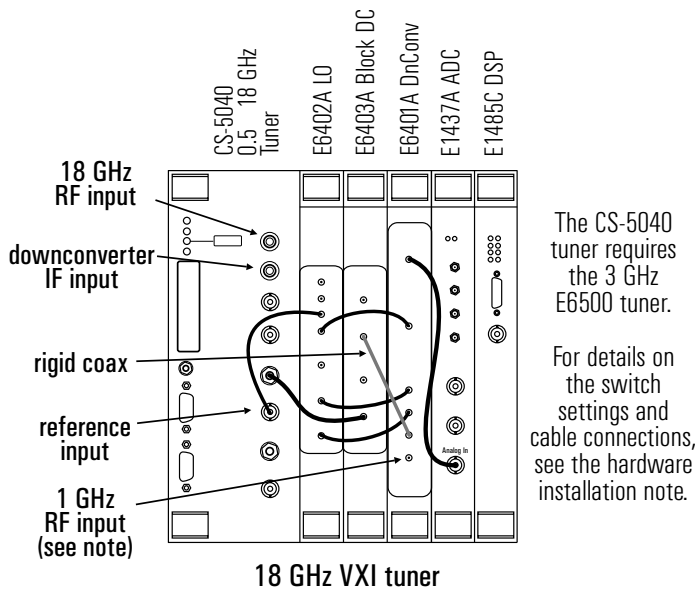

The Communication Solutions CS-5040 offers ranges of from 500 MHz to 18 GHz, 40 GHz, or 60 GHz.

Notes

The E6500-Series tuners allow measurements as low as 2 MHz but performance below 20 MHz may be degraded.

The 1 GHz input of the E6500 section of the CS-5040 tuner may be used by changing the tuner type with the application softkeys [MEASUREMENT], [FREQUENCY SETUP], [DOWNCNVRTR SETUP], [DOWN CNVRTR].

The purpose of the figures above is to illustrate cabling. The slots in which the *tuner* modules are installed or order of placement is not critical.

The ADC and DSP modules *must* be installed in adjacent slots with the ADC on the left and the DSP on the right, as shown. Option ATR is an exception; it has the E1562E module between the ADC and DSP modules.

System Configuration Files

There are two files in `/opt/hp3587s` named `CONFIGURATION` and `DOWNCONVERTER` which are used to define how the system starts.

CONFIGURATION

The `CONFIGURATION` file defines the basic system settings, such as:

- which peripherals are active
- application window size, position and name
- knob sensitivity
- active status for system messages (error, warning, status)
- definition of working and system directories
- hardware setup (logical address, etc.)
- options installed
- option codewords
- name of the file containing the downconverter definition(s)

If option AGG (Customization and Programming) is installed, this file also contains the name of files containing custom configuration information.

DOWNCONVERTER

The contents of the `DOWNCONVERTER` file depends on which ADC module is installed in the system. Three files are provided:

- `DOWNCONVERTER.e1430`
- `DOWNCONVERTER.e1437`
- `DOWNCONVERTER`

The `DOWNCONVERTER` file is a copy of one of the other two files. As shipped, the `DOWNCONVERTER` file contains the E1437A setup. If your system has an E1430A ADC module, copy the `DOWNCONVERTER.e1430` file to `DOWNCONVERTER`.

Starting and Stopping the System

Turning the power on starts the HP-UX boot process. The initial HP-UX boot up takes about 2 minutes. At the CDE login screen, login as user `vxi` (or a user specified by the system administrator).

To start the HP 3587S program, at a terminal prompt, execute the command `hp3587s`. After about 10 seconds, the opening screen should appear (see figure below) and then the display should appear with controls and softkeys below it.



If the system does not start as described, check that the V/743 Controller is in slot 0 of the HP 75000 Series C mainframe, the HP E3249 System Disk is in slots 2 and 3, the HP E1430A/E1437A ADC (Input) Module is in slot 4 and the HP E1485A/B VXI Signal Processor is in slot 5. If you have option ATR, Throughput Disk Capture, the E1562E should occupy slots 5 and 6 and the DSP should be in slot 7. Also, turn off the mainframe power switch and make sure each module is firmly seated in its slot.

For installation information on each of these modules, refer to the following.

HP 3587S/E3238S Hardware Installation Note

C-Size VXIbus Systems

HP E1430A/E1437A VXI ADC Operator's Guide

HP E1485A/B VXI Signal Processor Installation and Service Guide

HP A4362A Dial Box User's Guide

HP A4363A Button Box User's Guide

To shut down the analyzer, press [HOME] [SYSTEM] [SHUTDOWN].

Caution

Do not turn off the power until the HP-UX operating system has been properly shut down by the system administrator. This is usually done by the root user executing either `/etc/shutdown` or `/etc/reboot` at a terminal prompt. Do not turn the power off until the "cycle power" message appears on the terminal. Turning off the power before this message appears may result in lost data or damage to the system software. See the HP-UX System Administration manual for more detail.

Usage

The following listing describes the command switches. Many of these parameter values are specified in the /opt/hp3587s/CONFIGURATION file. Command switches provide the ability to override these "default" startup values. See "System Configuration Files" on page 13.

>> hp3587s -u

USAGE:

Switch <Parameters>	Description	Default Setting
-a address	Logical Address of E1485	[128]
-b buttonFile	Button Box Description File	[BUTTONSYSTEM]
-c colorFile	Color Description File	[COLORSYSTEM]
-d display	Display	[<IP_address>:0.0]
-e	Don't use Button Box	
-f font	Font	[10x20]
-g downloadable	Downloadable Filename	[SPECTRUM]
-h	Use VXI hardware	
-j menuFile	Menu System File	[MENUSYSTEM]
-k	Uncouple Center Freq and Span	[Coupled]
-l	List current setup	
-m	Function Key Menus Active	
-n	Don't use Knob Box	
-p printFile	Printer Configuration File	[PRINTSYSTEM]
-r accelFile	Keyboard Accelerator File	[ACCELSYSTEM]
-s spos	Signal Processor Operating System	[spos]
-t size	Window Size, 0:small 1:med 2:large	[2]
-u	Display this text	
-v macroFile	Macro Description File	[MACROS]
-w name	Name for X window	[HP3587S]
-x position	Window position	[1]
-y position	Window position	[1]
-z knobFile	Knob Description File	[KNOBSYSTEM]
-A mode	Beeper, 0:Off 1:On	[1]
-B	Monochrome Display Colors	
-C codeword	Security Codeword (16 characters)	[]
-E downFile	Down Converter Description File	[DOWNCONVERTER]
-F font	Title Font	[12x24]
-G codeword	ATR Option Security Codeword	[]
-I address	Logical Address of E1430 or E1437	[129]
-K sensitivity	Knob Sensitivity	[10]
-L mode	Local Bus Mode, 0:Off 1:On	[1]
-M bytes	Maximum Memory for Data	[16000000]
-N lif_volume	E1562 LIF Volume Name (Opt ATR)	[default]
-O	Don't Display Opening Screen	
-P filename	Power Up Instrument State File	[]
-Q name1	Power Up Downconverter	[]
-S directory	System Directory	[/opt/hp3587s/]
-T address	Logical Address of E1562 (Opt ATR)	[0]
-W directory	Working Directory	[./]
-X mode	Command Port, 0:Off 1:On	[1]
-Y key	Command Port Shared Ram Key	[0x3587]
-Z interface	VXI Interface Name	[vxi]

Working With the Display

This chapter shows how to use the display features of the HP 3587S.

Introduction

The following figure illustrates the block diagram of the HP 3587S. Each of the blocks has parameters that you set to take a measurement, collect measurement data, process measurement data, display the processed data.

When you make a measurement, follow these steps:

1. Set up the input and measurement parameters to make the desired measurement.
2. Set up the display to view the results in the format that most-efficiently gives you the information you need.
3. Store the results (optional).

The following chapters are arranged to discuss each of these steps by presenting tasks that introduce you to features and their supporting parameters.

This chapter covers the display features that process data in the CPU block.

Chapter 3 covers making measurements; data processed by the ADC and DSP blocks.

Chapter 4 covers collecting data; data processed by the throughput capture, signal capture, and display data processed by the CPU blocks.

Note

Many of the examples in the following chapters use demonstration data files delivered with the HP 3587S software under `/opt/hp3587s/demos`. To work properly, these data files need to be copied to your home directory. For example:

```
% cd
% cp /opt/hp3587s/demos/*.dat .
% hp3587s
```

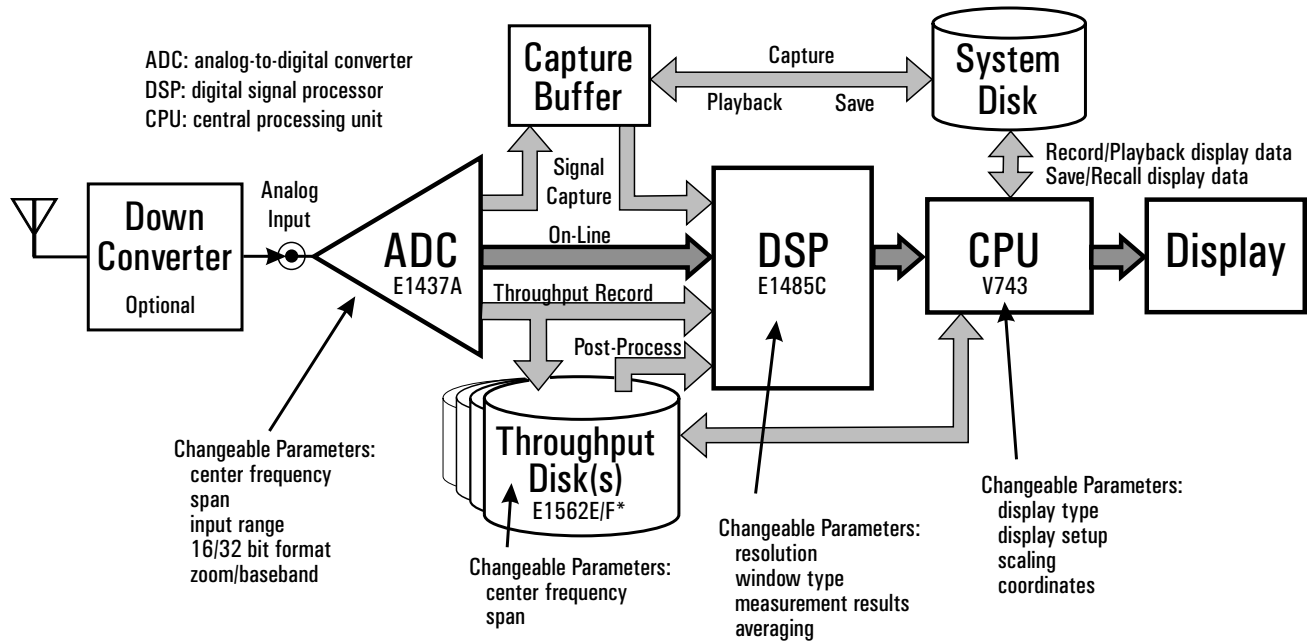

*Option ATR hardware.
 SCSI disks connected
 together with external
 (front-panel) cables.

On-Line Help



1. Hold down the [Shift] key while pressing the function of interest. The function can be one of the function keys (F1 – F8) on the computer keyboard, one of the buttons on the button box, or you can turn one of the knobs on the knob box. For example, to get help for the [INPUT SETUP] function, hold down the [Shift] key and then press [INPUT SETUP]. A description of the function appears.
2. Turn the Help display off by pressing any key on the computer keyboard.

The function for which you are accessing help is not activated unless you press it again without holding down the [Shift] key.

To view all the help text for the system in index form, press [SYSTEM] [HELP INDEX]. Use the keyboard up/down arrows or the lower right knob on the knob box to scroll through the help index listing.

You can also key in a function name and press [Enter/Return] to view the help for that function. Each entry includes the key path to the function and a description of the function. Press [Enter/Return] or [ESC] to exit the help index.

See “Printing” on page 52 for instructions on printing help.

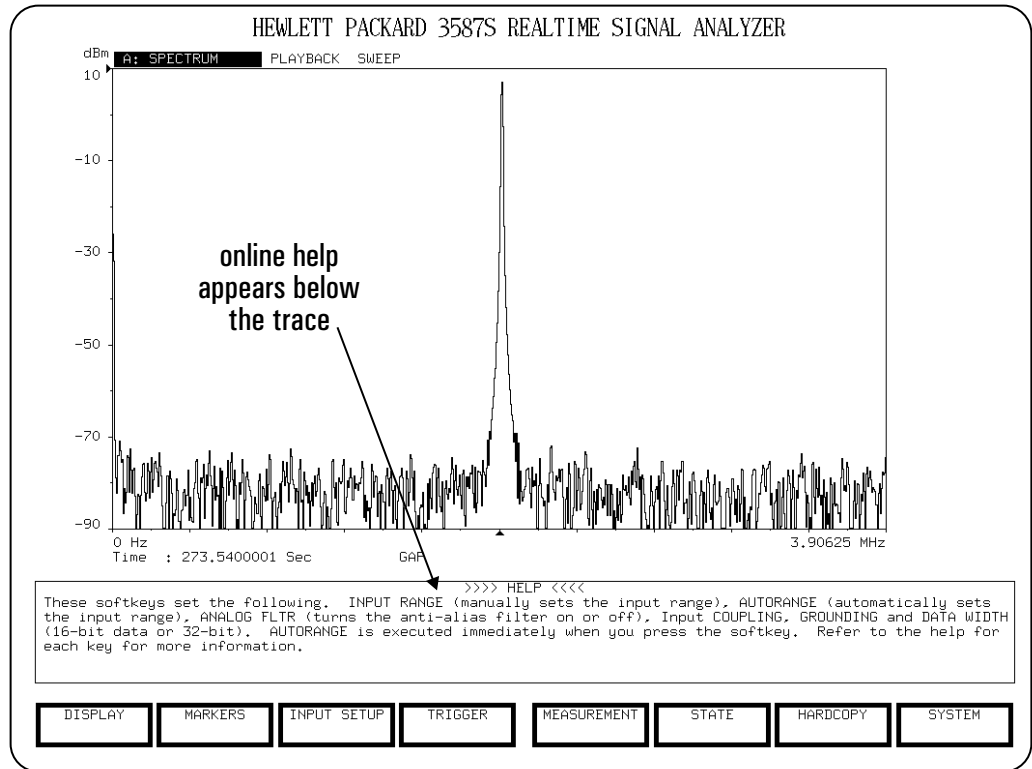

To get information on any function, hold down the shift key and click on the function button.
To display the help index, press [Home] [System] [Help Index].

Playing a Stored Record

Many of the tasks in this book require loading a stored file and playing it back.

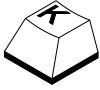

1. Press
[HOME]
[MEASUREMENT]
[RECORD/PLAYBACK]
[FILENAME]
2. Press the up or down arrow on the computer keyboard to scroll through existing data files until the "SWEEP" filename appears and press [Return].

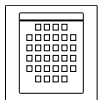

3. Press
[MODE]
[PLAYBACK]
4. Press
[Run]
5. Press [m] on the keyboard to display the measurement state used to take the stored file. Notice in the third column that only SPECTRUM data exists in this file. This means you cannot display histogram or time using this data.

SWEEP is a record of a sweeping sine wave stored on the system disk which sweeps from 1 MHz to 3 MHz. Notice that the record is repeatedly played back. [m] is one of several keyboard accelerators that let you quickly execute common tasks. See Appendix A (page 105) for a complete list of keyboard accelerators.

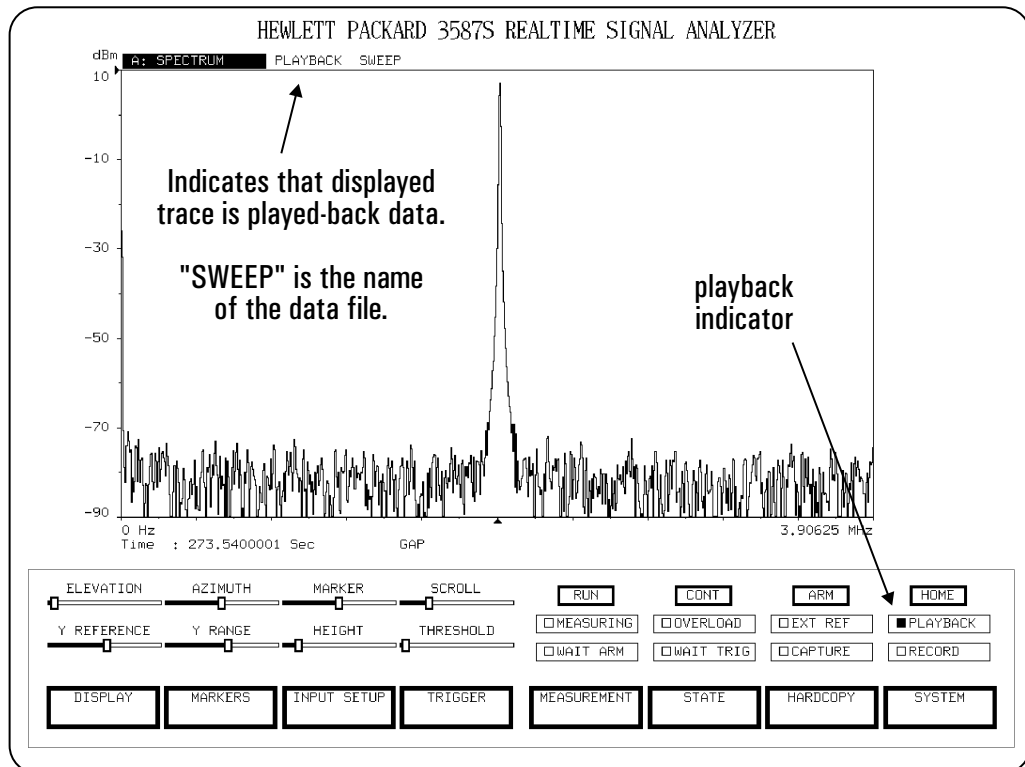

Spectrum Display

Perform the steps in the task “Playing a Stored Record”
Then:

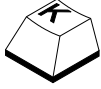

1. Press
[Spectrum]

The spectrum display type is the default.

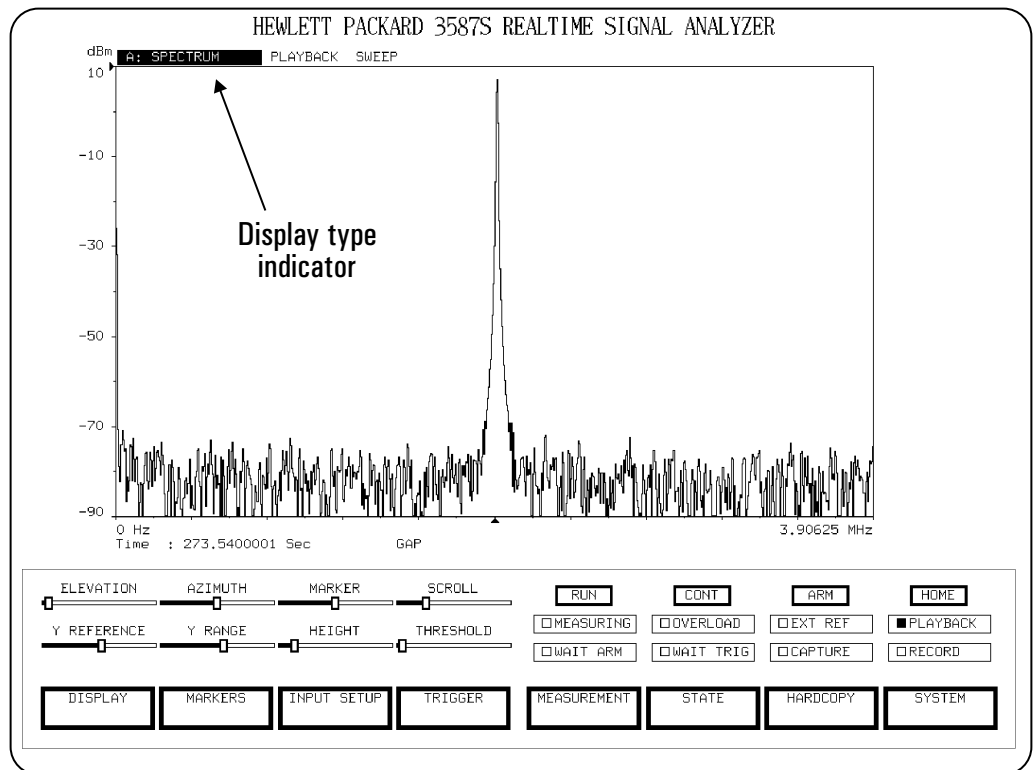

Y-Axis Scale

Perform the steps in the task “Playing a Stored Record” on page 22.
Then:

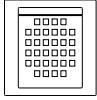

1. Press
[X/Y RANGE]



2. Turn
[Y RANGE] and notice the new y-axis minimum value.

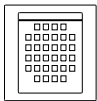

3. Turn
[Y REFERENCE] and notice the new y-axis maximum value.
4. Press
[Y Auto Scale] and notice the y-axis range and reference are automatically adjusted.

[Y RANGE] increases and decreases the y-axis scale relative its reference. The triangle on the y-axis is the reference location. For frequency domain measurements (Spectrum, Spectral Map, Color Map, etc.) [Y REFERENCE] is at the top of the y-axis for the trace.

For time-domain measurements (Time, Time Map, and Strip Chart), [Y REFERENCE] is at the middle of the y-axis for the trace. For amplitude domain measurements (Histogram, PDF and CDF), [Y REFERENCE] is at the bottom of the y-axis for the trace. [Y Auto Scale] automatically adjusts the y-axis range and reference level so that the data fits on the display.

As you move the knob function, its respective slide bar indicator also moves. This gives visual feedback as you make adjustments as to where you are in the range of the function. The slide bar controls appear below the trace display.

You can also move the slide bars using the computer mouse. Point to the slide bar and then press the left mouse button and hold it down while moving the mouse (called dragging the mouse) until you have made the desired adjustment.

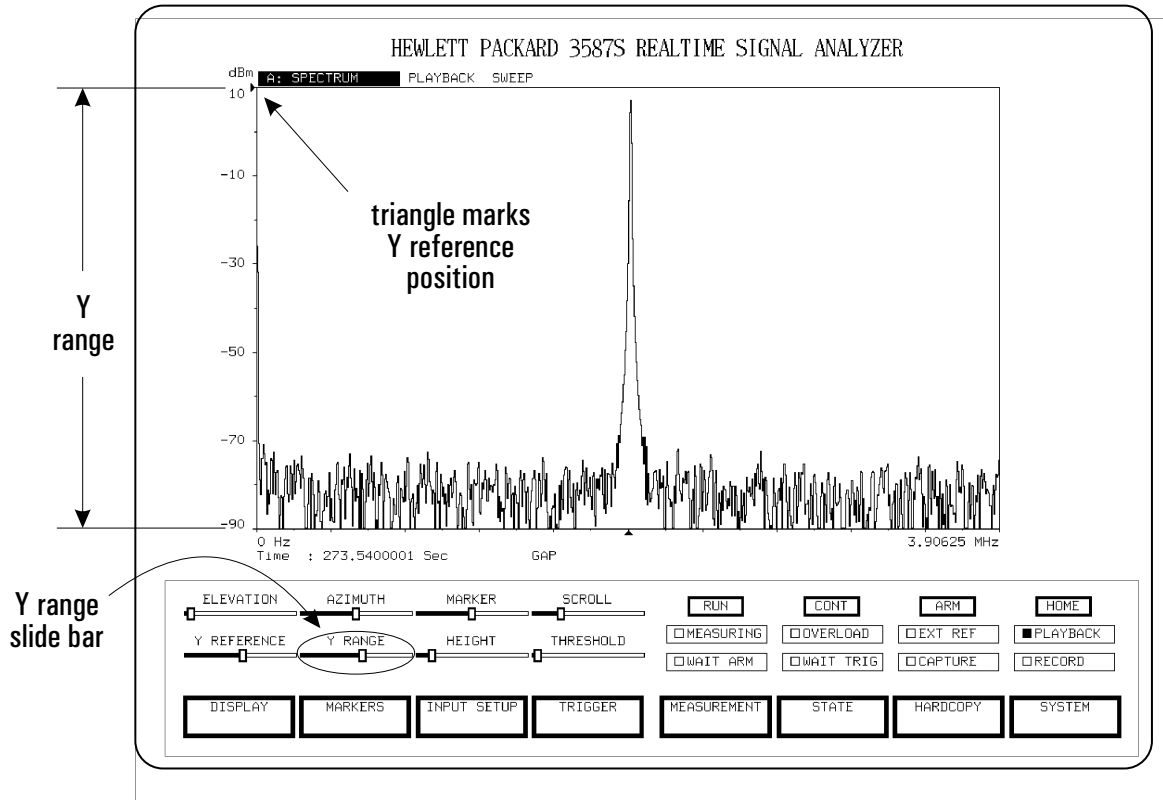

The Y Range may be modified with either the knob box or the mouse/slide bar.

X-Axis Scale

If you are playing back the "SWEEP" file, you may want to press [Pause] before starting this task.

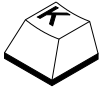

1. Press
[Monitor]

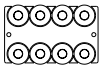

2. Turn
[X MAGNIFY]

3. Turn
[X REFERENCE]

[X MAGNIFY] decreases the x-axis scale around its reference. The triangle on the x-axis is the [X REFERENCE] which is located at the center of the x-axis for the trace. Changing the [X REFERENCE] changes which x-axis value appears at the center of the display.

[X MAGNIFY] must be >1 before the [X REFERENCE] can be changed.

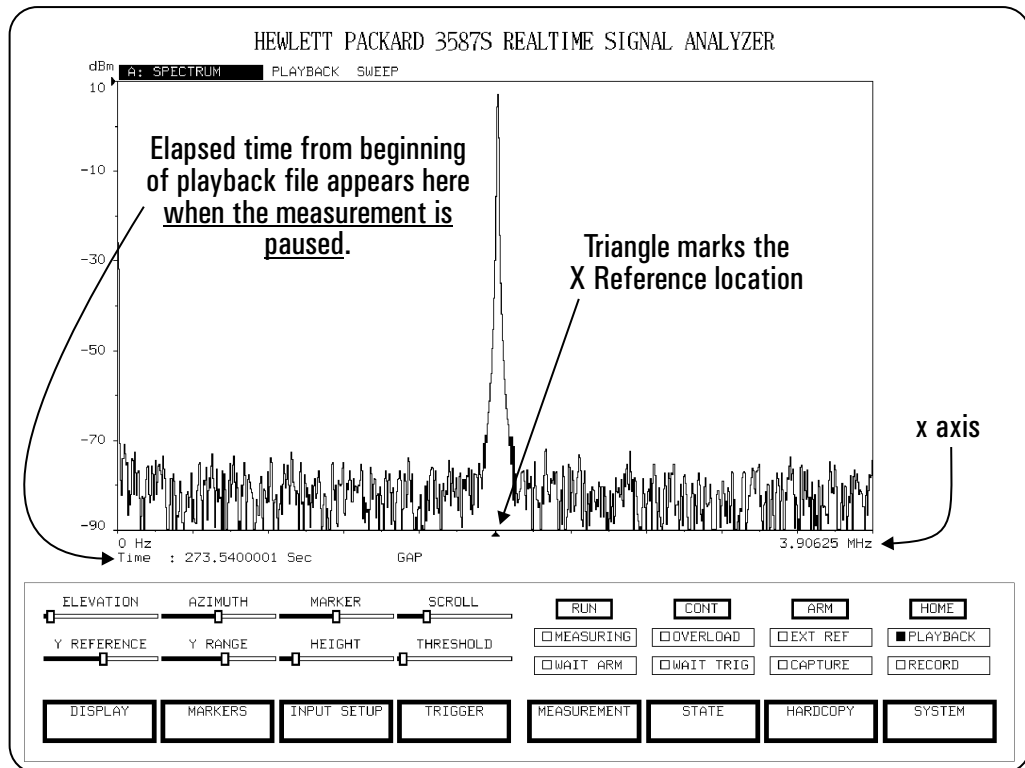

Using the Marker

If you are playing back the "SWEEP" file, you may want to press [Pause] before starting this task.

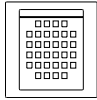

1. Press
[Single Mkr]
[Marker To Peak] to turn on the marker and move it to the highest signal.
The read-out for x-axis and y-axis marker position appears below the display.



2. To move the marker, turn
[X/Y Display]
[MARKER]



3. Press
[Rel Mkr]
[Next Peak R.]

4. The relative marker read-out (denoted by "delta") gives the difference between the x-axis and y-axis positions of the main marker (rectangle) and the relative marker (cross).

For map displays, [Single Mkr] reads out the time at the end of the data record of the highlighted trace. This time is relative to the beginning of map acquisition. Similarly, [Rel Mkr] reads out time between two highlighted traces for map displays. See "Spectrogram Display" on page 30 for an example.

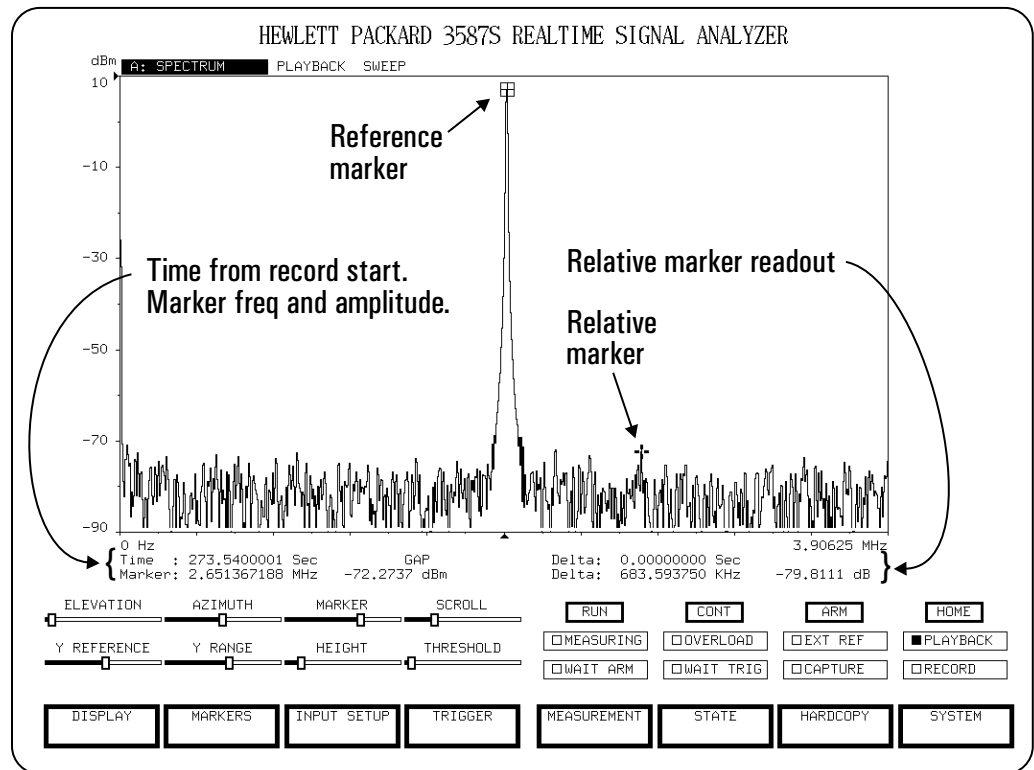

Rollogram Display

Perform the steps in the task “Playing a Stored Record” on page 22
 Then:

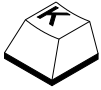

1. Press
 [HOME]
 [DISPLAY]
 [DSPY TYPE]
 [ROLLOGRAM]

After the display has had time to completely sweep the screen, it should look something like the figure below. A rollogram is a spectrogram that doesn't scroll up or down the display. This displays trace information faster than the spectrogram display type can because fewer traces move. Changing Elevation has no effect on the display while the measurement is running.

2. Press
 [Pause/Cont] to pause the display scrolling.
3. Turn
 [ELEVATION] to increase or decrease the spacing between the rollogram lines.

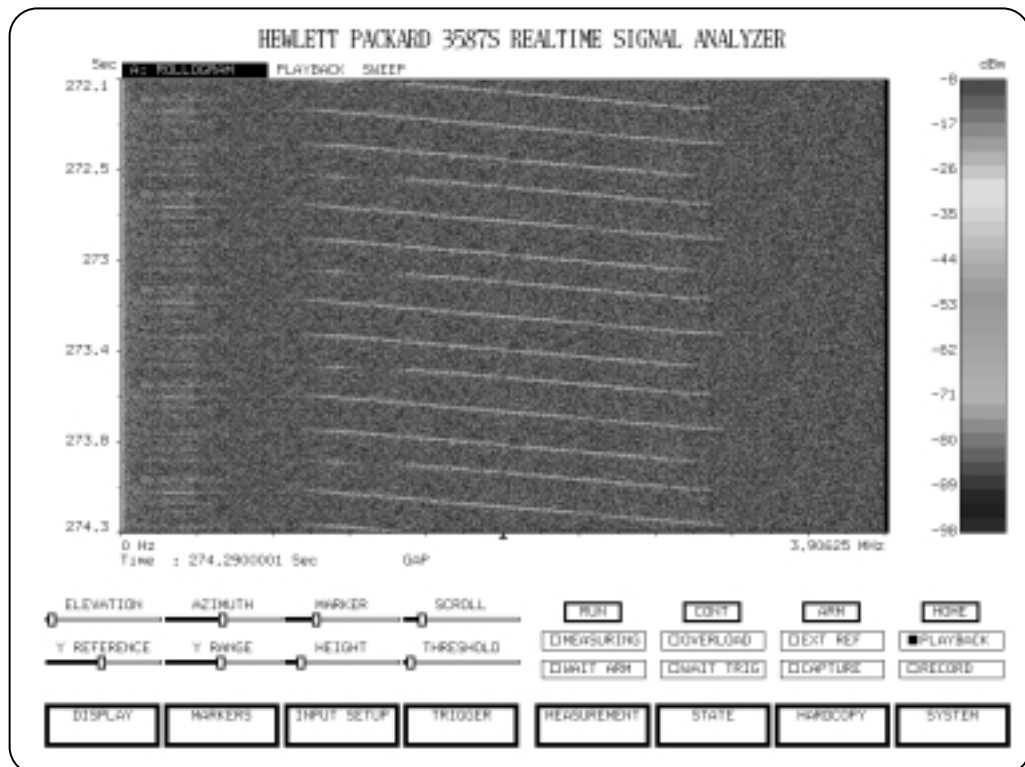
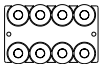

In a rollogram display, information is updated by a scrolling update line.

Digital Persistence Display

Persistence allows a trace such as a spectrum to remain on the display longer than it would normally. To use digital persistence, playback the SWEEP data and then perform the following:

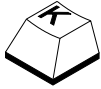

1. Press
[HOME]
[DISPLAY]
[DSPLY TYPE]
[NEXT]
[PR SPECTRUM]

The display shows the spectrum repeatedly with the most recent trace in deepest red, the 16th trace in green, and the 32nd trace in deep blue as shown in the following illustration. Note that the number of traces displayed is determined by the number of colors selected under (starting from the HOME menu) [DISPLAY], [DSPLY SETUP], [3-D MAP COLORS].

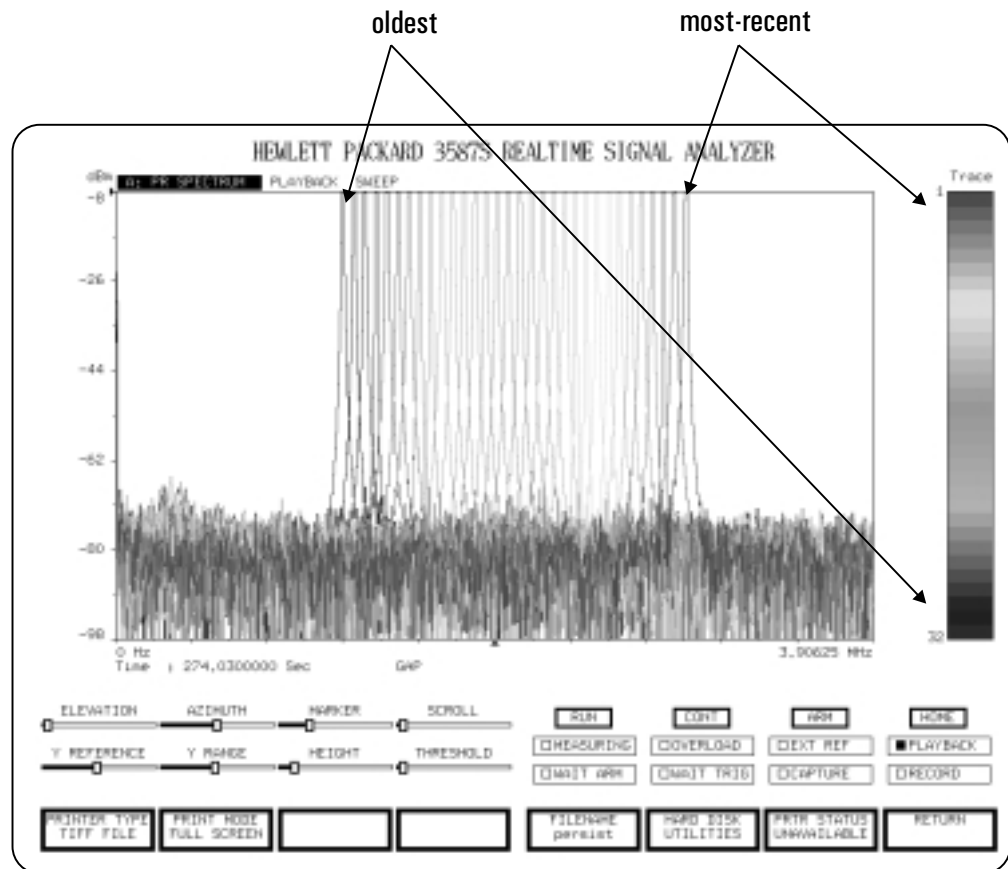

Digital persistence shows the most-recent information in red and the oldest information in blue.

Spectrogram Display

Perform the steps in the task “Playing a Stored Record” on page 22
Then:

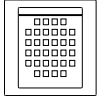

1. Press
[Spectrogram]
[X/Y Display] (this enables the display controls for the knob box)



2. Turn
[ELEVATION] to increase or decrease the spacing between the spectrogram lines.

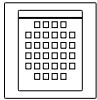

3. Press
[Scroll Dir] and notice each new trace now scrolls down the display.
[Pause/Cont] to pause the display updating.



4. Click on any portion of the spectrogram display. Notice the highlighted trace and its time read-out relative to the beginning of the record.



5. Press
[Rel Mkr]



6. Click on another portion of the spectrogram display. Notice the new highlighted trace. The “delta” time below the display represents the time between the marked trace and the relative trace.

To reposition the reference marker, move the cursor to point at the new position and click the right mouse button. To reposition the regular marker (relative to the reference marker), move the cursor to point at the new position and click the left mouse button. To move both markers, hold down the middle mouse button, move the mouse to the new position, and release the button.



7. Press
[Pause/Cont] to resume updating the display.

A spectrogram is similar to a spectral map except amplitude is represented by color. A color scaling bar on the right side of the display maps each amplitude to a color.

The trace markers are useful for determining the timing between events of interest such as duration of transmission of frequency hopping signals. This time refers to the time at the end of each data record since the [Run] key was pressed. “Delta” time refers to the time between the ends of each trace.

Trace markers may also be used to select traces to view in another grid using a different display type. For example, if you have a [Dual Trace] display with a [Spectrogram] (which has multiple traces) in trace A and a [Spectrum] in trace B, and both traces are active, clicking on any trace in the spectrogram shows that trace as a spectrum in trace B. Turning the [Scroll] knob lets you view each consecutive trace of the spectrogram in trace B.

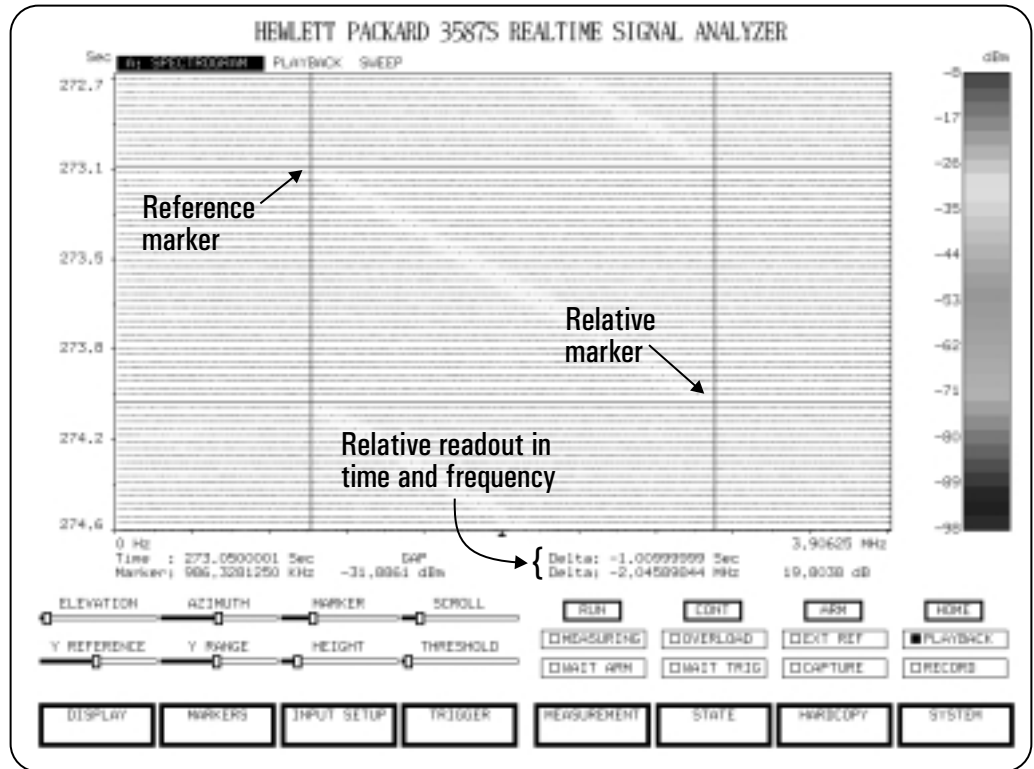

Using relative markers on a spectrogram display.

Mouse

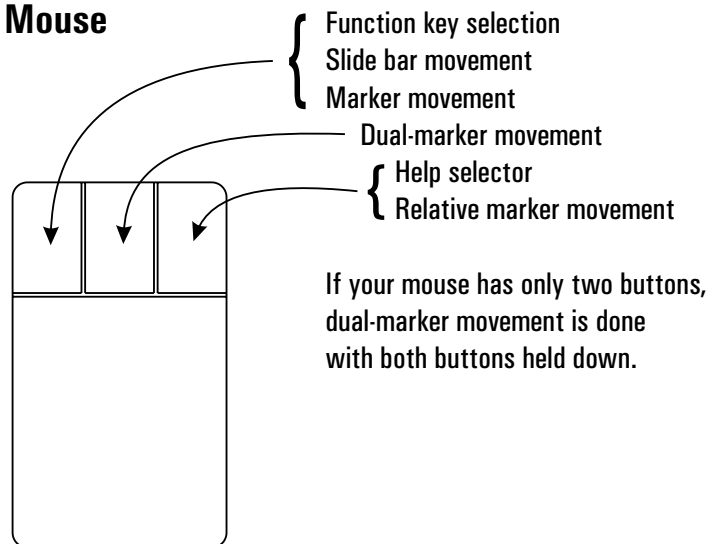

Color Map Display

Perform the steps in the task “Spectrogram Display” on page 30.
Then:

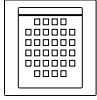

1. Press
[Color Map]
[X/Y Display] (this enables display controls for the knob box)



2. Turn
[ELEVATION] to change the spacing between the color map lines.



3. Press
[Scroll Dir] and notice new scroll direction.



4. Turn
[AZIMUTH] and notice the change in horizontal spacing between map lines.

5. Turn
[THRESHOLD] to eliminate the baseline noise as shown below.

A color map is similar to a spectral map except amplitude is represented both graphically and by way of color. A color scaling bar to the right of the display maps each amplitude to color.

All y-axis values less than the threshold value are set equal to the lowest displayed value. The effect, in this case, is to eliminate the noise fluctuations on the display.

[THRESHOLD] has the following characteristics.

If the threshold is below all signals, including the noise, the complete trace is shown.

If the threshold is in the “middle” of the noise floor, the display shows lines drawn between the threshold level and the lowest portion of the scale.

If the threshold is very high, only the data above the threshold is shown. The sides of signals show lines drawn from the threshold level to the lowest portion of the scale.

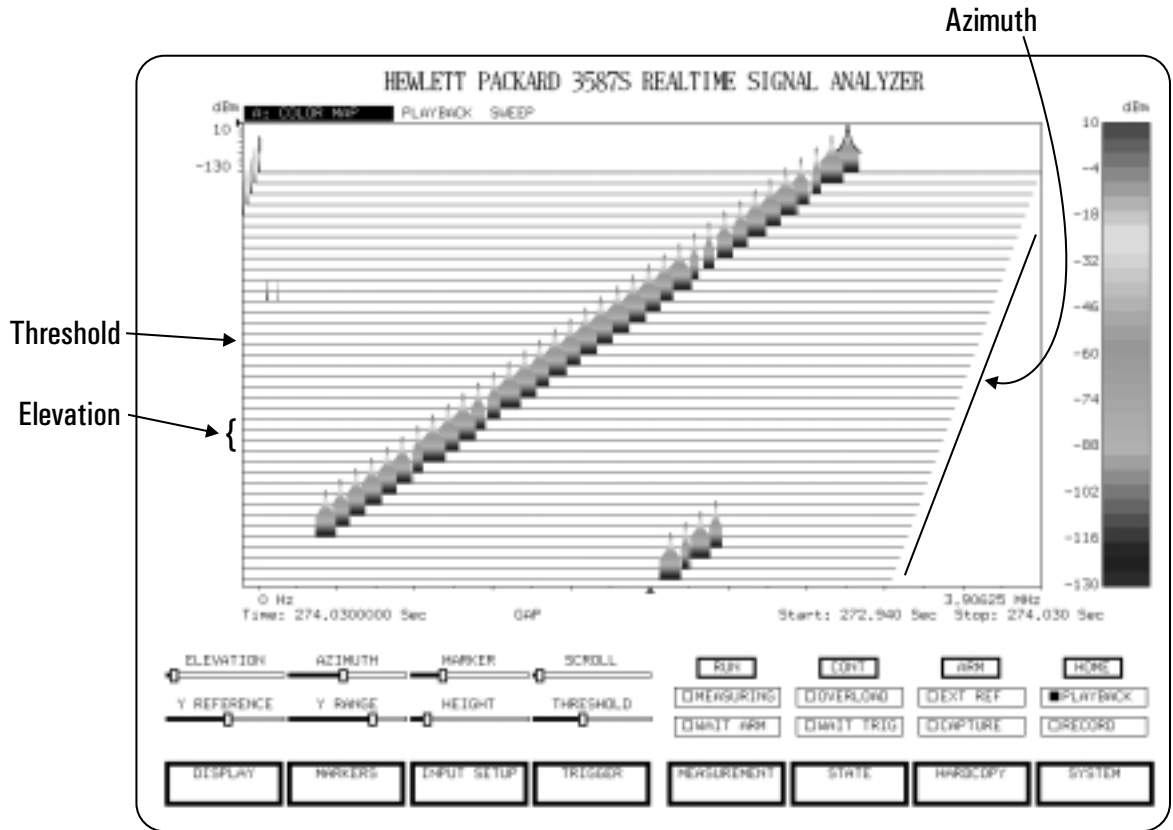

A color map represents amplitude graphically and with color.

Map Colors

This exercise demonstrates how to select or change colors used in the color map display.

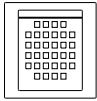

1. Complete the steps given in “Color Map Display” on page 32.
2. Press
[Color] (outlined in green)
This enables the color controls for the knob box.



3. Notice the labels for each of the slide bar controls below the trace display have changed to the same labels in green on the knob box.
4. Turn
[COLOR MAP] (upper left knob). Slowly turn the knob all the way to the right and to the left to see all of the map color choices.



5. Press
[HOME]
[DISPLAY]
[DSPLY SETUP]
[3-D MAP COLOR]
[SATURATION]
Notice SATURATION is the active entry as shown by the lower right slide bar, and is therefore adjustable with the lower right knob on the knob box.



6. Turn
[SATURATION] (lower right knob). Slowly turn the knob and notice the changing amount of white mixture in each map color.



7. Press
[LUMINANCE]



8. Turn
[LUMINANCE] (lower right knob). Slowly turn the knob and notice the changing amount of black mixture in each map color.

The color scale bar along the right side of the screen indicates the amplitude each color represents. This color scale bar appears on spectrogram and color map displays. The next task shows how to change the color scaling.

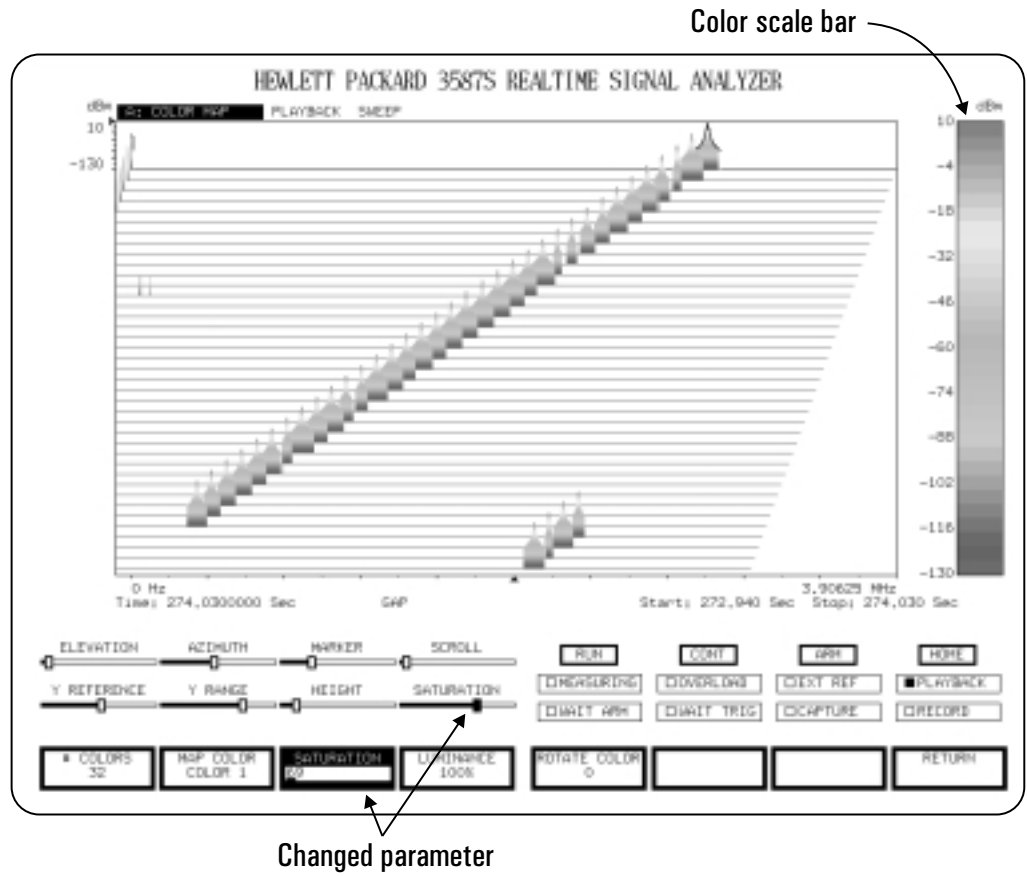

When changing the color configuration, such as saturation or luminance, the THRESHOLD (lower right) slide bar changes its name to depict the parameter being changed.

Map Color Scaling

Perform the steps in the task “Spectrogram Display” on page 30.
Then:

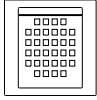

1. Press
[Color]



2. Press
[HOME]
[DISPLAY]
[DSPY SETUP]
[IMAGE ENHANCEMENT]
[MAP MODE]
[LOG]



3. Turn
[LOG FACTOR] (bottom row)



4. Press
[LINEAR]
[RETURN]
[Y BREAKPOINT]



5. Turn
[Y BREAKPOINT] (bottom row)
[X BREAKPOINT] (bottom row)

Map color scaling changes the way colors are distributed over the displayed amplitude range. The colors can be distributed either logarithmically or linearly. For logarithmic color map modes, notice the map mode indicator at the bottom of the color bar on the right side of the display. This indicator gives a graphical representation of how the colors are distributed over the amplitude range. As you change the [LOG FACTOR], the small red trace changes accordingly and represents which portion of the color map is emphasized (or “spread out”) to represent more levels. Positive log factors give a greater distribution of the top colors of the color map. Negative log factors give a greater distribution of the bottom colors of the color map.

With a linear color map mode, the map mode indicator also appears at the bottom of the color bar. In this case, a straight line is drawn between the X and Y Breakpoints and the ends of the color scale. ([LOG FACTOR] does not apply in this mode.) The small red trace shows where the x,y breakpoint falls in relation to the color scale endpoints. By placing the x,y breakpoint appropriately, you can have a piece wise linear color scale that uses dark range stretching or light range stretching.

Map mode indicator

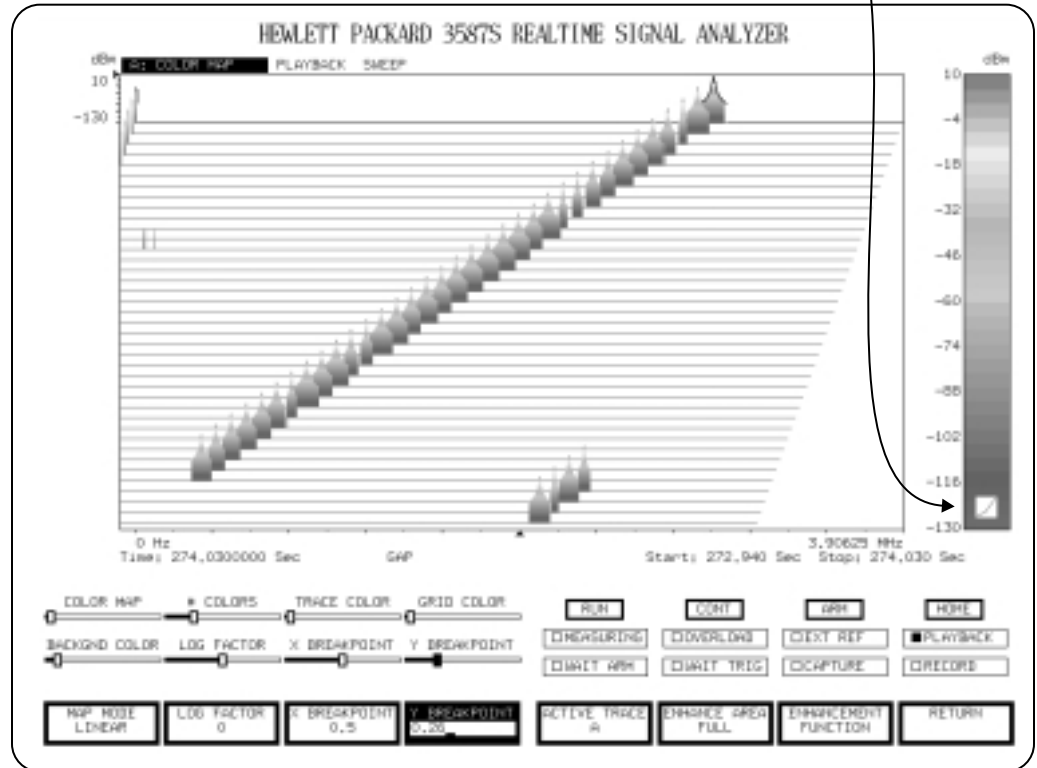

Map color scaling specifies how colors are distributed over the displayed amplitude range.

Image Enhancement

The display type should be set to spectrogram or rollogram and the ELEVATION set to 0 (zero).

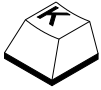

1. Press
[X/Y Display]

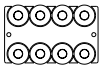

2. Turn
[ELEVATION] to a setting of zero.



3. Press
[HOME]
[DISPLAY]
[DSPLY SETUP]
[IMAGE ENHANCEMENT]
[ENHANCE AREA]
[LEFT]

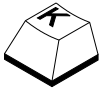

4. Press
[RETURN]
[ENHANCEMENT FUNCTION]
[SPATIAL FLTR LP1]

As shown in several of the previous tasks, there are many ways to enhance a spectrogram or rollogram display to help visualize signals and their attributes. Another set of enhancement functions are included in the 3587S software that are based on common image enhancement techniques.

Convolution Filtering

An input signal displayed as a spectrogram with zero ELEVATION is an image. This image is a rectangular region with as many as 128 different colors. Algorithms can enhance its high-frequency content, low-frequency content, and/or edges. The most fundamental algorithm is a convolution.

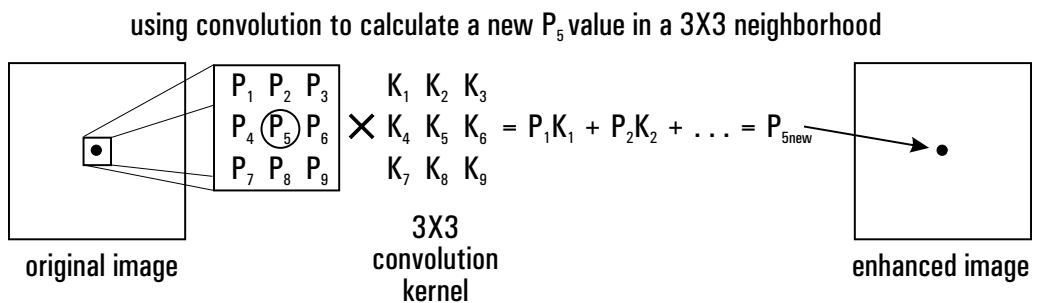

Convolution creates a new value for each pixel based on its value, the values of its neighbors, and a predefined convolution kernel. Kernel values are listed in Appendix D.

Various *low-pass* or *high-pass* spatial filters are implemented by taking an $n \times m$ kernel and convoluting it with the image. Using different sets of kernel coefficients, this method can also *enhance edges* in the image where an edge is defined as a rapid change in color.

Horizontal and *vertical* matched-filter convolution kernels are used to enhance edges with a specific orientation.

Laplace edge filtering highlights edges with any orientation, generates sharper edge definitions than most other edge enhancement methods, and highlights both positive and negative (slope) edges.

The *blurring* kernel is used to spread out a signal. This is useful when looking for frequency changes over time.

Median Filtering

Another enhancement algorithm is *median filtering*. It eliminates random noise in an image as explained in the following figure.

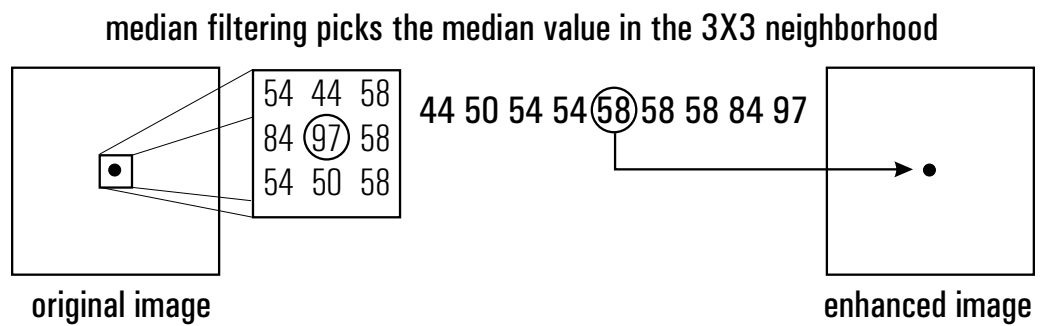

Median filtering reduces random noise.

Appendix D lists the convolution kernel definitions (kernel values) available.

Spectral Map

Perform the steps in the task “Playing a Stored Record” on page 22.
Then:

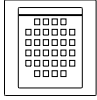

1. Press
[Pause/Cont] to pause the display scrolling.
[Spectral Map] to select the spectral map display
[X/Y Display] (this enables the display controls for the knob box)



2. Turn
[ELEVATION] to change the spacing between the spectral map lines.

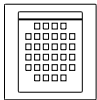

3. Turn
[AZIMUTH] and notice the change in horizontal spacing between map lines.

4. Press
[Hidden Line]
[Scroll Dir] and notice new scroll direction. See first figure.



5. Turn
[THRESHOLD] to eliminate the baseline noise as shown in the second figure.



6. Press
[Grid] to turn on the grid. When displaying spectral maps, the grid appears as a baseline for each trace. See the third figure.

7. Press
[Grid] to turn the grid back off.



8. Turn
[THRESHOLD] back to a setting of 0.
[Monitor]

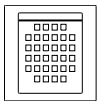

9. Press
[X MAGNIFY] to expand the X axis
[Wire Frame] to draw lines between the same-frequency points of each spectral trace. See the fourth figure.

A spectral map simultaneously displays amplitude versus frequency of several data records in successive time intervals.

The hidden line feature enhances depth perception and reduces confusion in map modes. Turning it on slightly decreases the display update rate. It is most effective for displays with a high ELEVATION setting.

The wire frame makes it easier to see spectrum contours across an entire map. It is only displayed when a measurement is paused and is most effective for displays with a small ELEVATION setting.

An azimuth of 0 gives the maximum display rate.

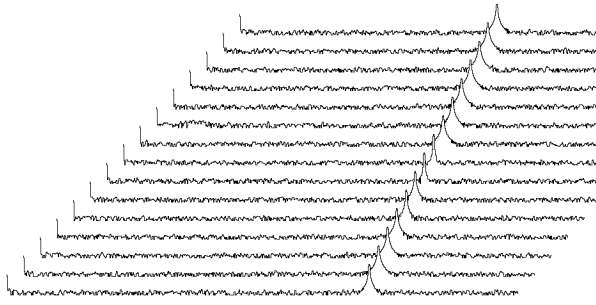

1. Spectral Map with hidden lines on

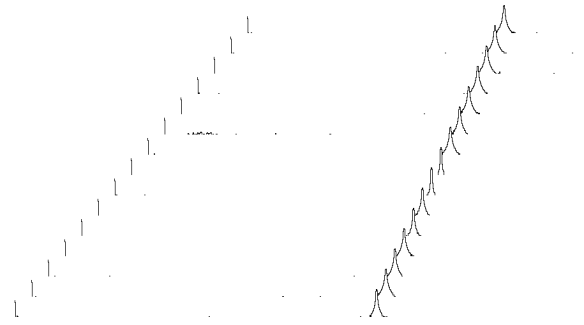

2. Spectral Map with raised threshold

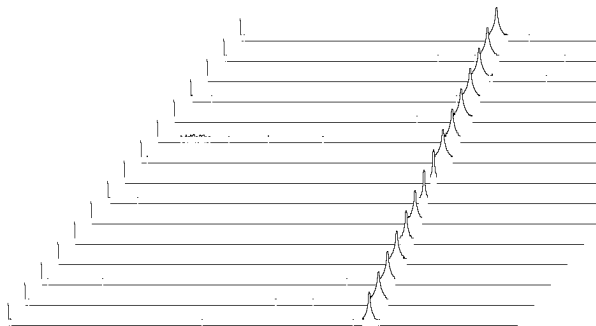

3. Spectral Map with raised threshold & grid lines on

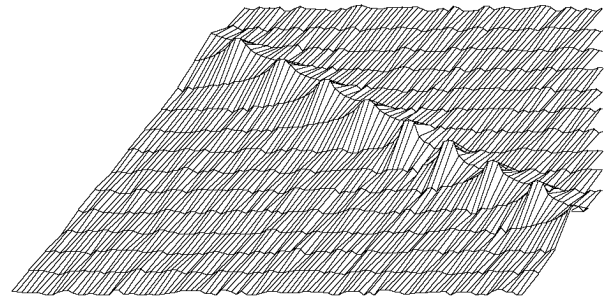

4. Spectral Map with wire frame on

Active Trace

Perform the steps in the task “Playing a Stored Record” on page 22.
Then:

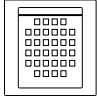

1. Using the button box, press
[Triple Trace]
[A]
[B]
[C]. The trace label in the upper left-hand corner of each trace are inverse video when the trace is active.
2. To illustrate some of the active trace rules, press
[B]
[Spectrum]
[Grid] and notice the grid only turns on in trace B.
3. Press
[All Traces]
[Grid] and notice the grid turns on in all of the traces (unless one of the traces is a map which does not allow for grids).

In step 1, only one trace is active at a time. In step 3, all three traces are active. When you pressed [Grid] again, the grid for trace B did not toggle to off because the analyzer assumes all three traces have the same state as trace A. In the example, the initial state of the trace A grid is initially off.

An active trace softkey appears in several of the keyboard menus. The selections under this key also include active trace combinations such as AB, AC and BC. This key appears in several menus because the settings which appear at the bottom of many of the other softkeys apply only to the setting of the active trace. For example, if trace A is active, the [DSPLY TYPE] of trace A is given in the [DISPLAY] menu. If more than one trace is active, the softkey indicates the setting for whichever active trace is “closest” to trace A. For example, if traces B and C are active, the softkeys indicate the settings for trace B. See the following figure.

Inverse video indicates active trace

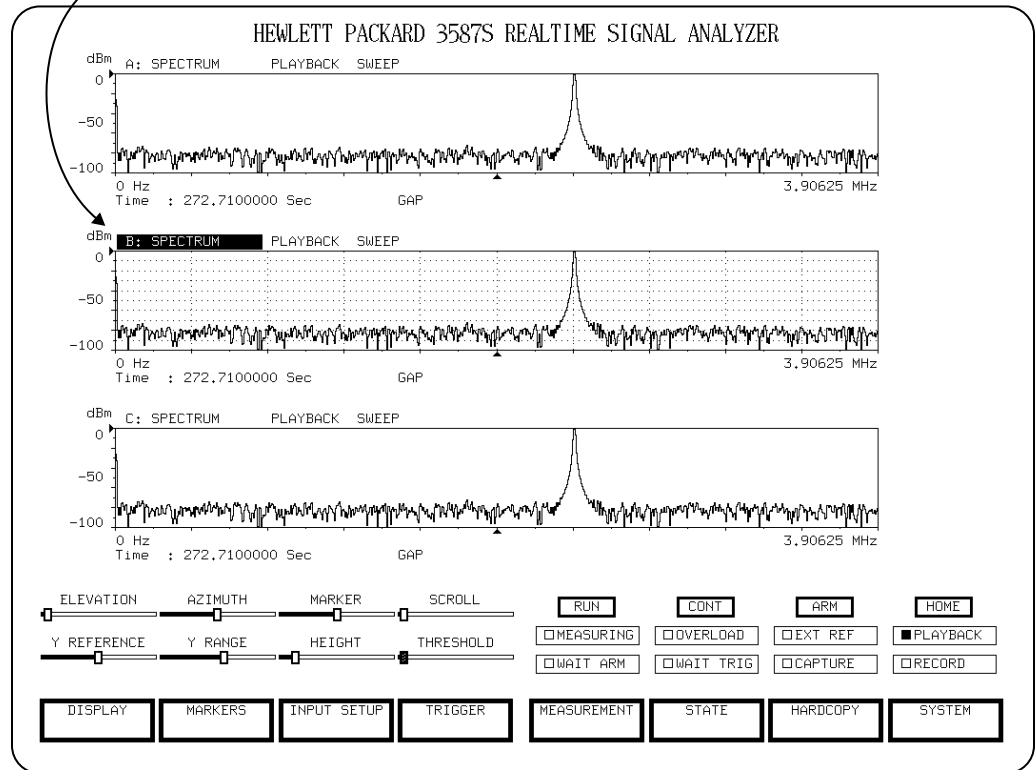

The number of displayed traces and active trace control is easily specified with the button box.

Strip Chart

To display stored data in a strip chart, the data must have been stored with the TIME measurement result turned on. The file named "SINE" is such a file. To play it back:

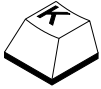

1. Press
[HOME]
[MEASUREMENT]
[RECORD/PLAYBACK]
[FILENAME]
2. Press the up or down arrow on the computer keyboard until the "SINE" filename appears (or type it in) and press [Enter/RETURN] once.
[MODE]
[PLAYBACK]
3. Turn on time data. Press
[RETURN]
[MEASUREMENT RESULTS]
[TIME] (turns time data on)
4. Select strip chart display type. Press
[HOME]
[DISPLAY]
[DSPLY TYPE]
[NEXT]
[STRIP CHART]
5. Select number of records to display. Press
[RETURN]
[DSPLY SETUP]
[PRESENTATION]
[STRIP CHART]
[32 RECORDS]
6. Start the playback. Press
[Dual Trace]
[B]
[Time]
[Run]

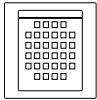

Trace A (top) shows 32 data records in strip chart form. Trace B (bottom) shows the most recently displayed data record (the right-most data record) in the time domain. This lets you have a closer examination of each record and is useful for evaluating time-versus-amplitude characteristics of signals such as rise time and overshoot.

The most recent time record is highlighted and displayed in trace B

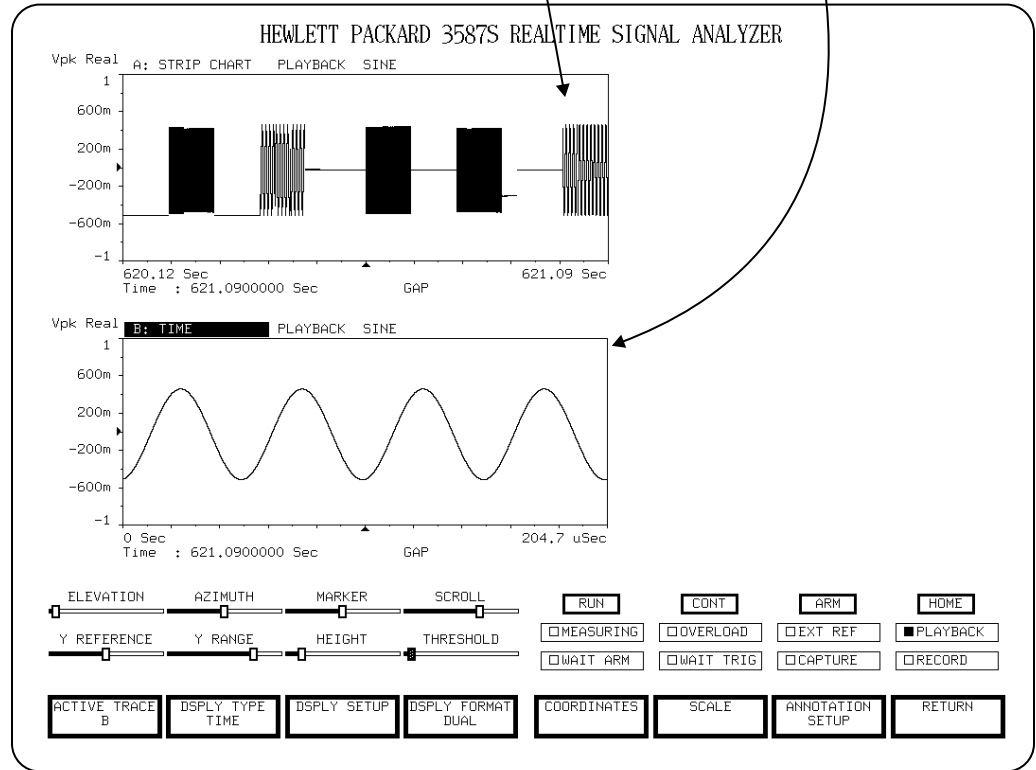

Strip charts display time-domain data.

Strip Chart Markers

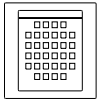

1. Complete the steps in “Strip Chart” page 44.

2. Press

[All Traces]

[Pause/Cont] to pause updating the strip chart.



3. Click on any portion of the strip chart and notice the highlighted portion of the strip chart is displayed on trace B.

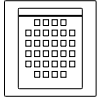

4. Press

[Triple Trace]

[C]

[Spectrum]

[All Traces]



5. Click on any portion of the strip chart and notice the highlighted portion of the strip chart is displayed on trace B in the time domain and trace C in the frequency domain.

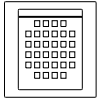

6. Press

[Pause/Cont] to continue updating the strip chart. Notice trace B and trace C resume showing the most recent record.

In the example display which follows, a “GAP” indicator appears below each trace which indicates the data is not real-time data. This message appears because the measurement was paused and, as a result, a time gap occurred between acquisition of data records.

With all traces active, clicking on any portion of the strip chart shows the highlighted time record in the other traces.

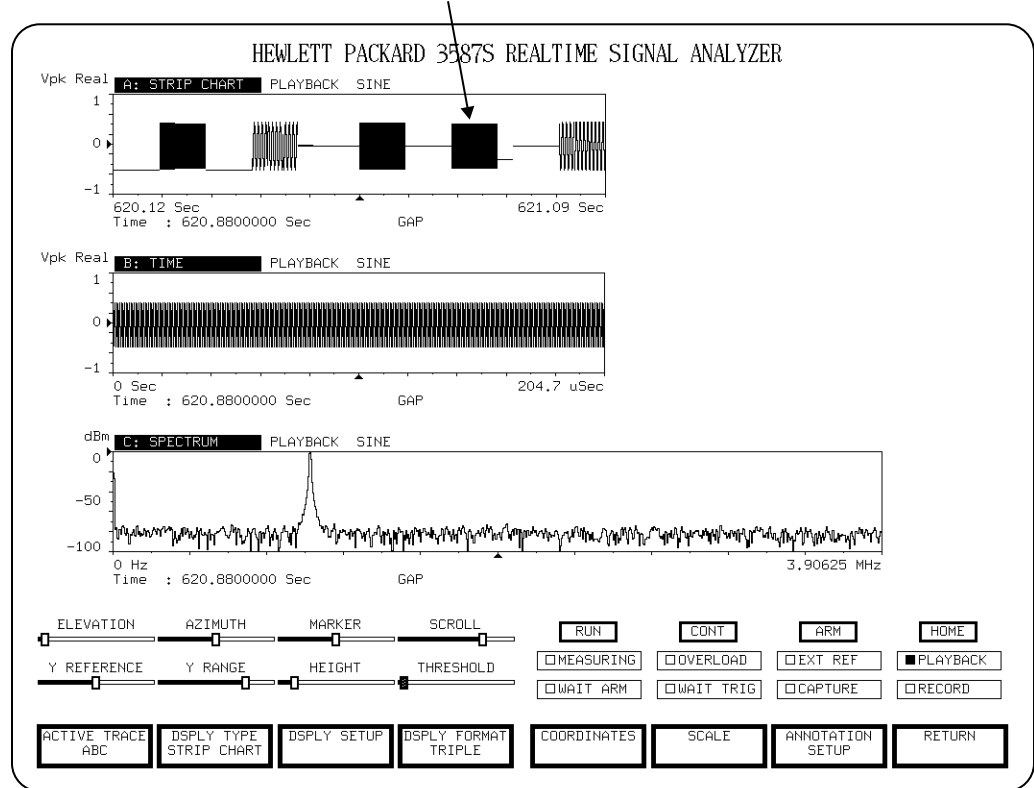

Strip chart markers help you examine time data quickly.

Histogram, PDF, and CDF



1. This step changes the playback signal from a sweeping sine wave to a sine wave with varying modulation to help illustrate the amplitude domain functions. The signal was recorded with the [AMPLITUDE] measurement result turned on.

Press
[HOME]
[MEASUREMENT]
[MEASUREMENT RESULT]
Toggle to [AMPLITUDE ON]
[RETURN]
[RECORD/PLAYBACK]
[FILENAME]

Press the up or down arrow on the computer keyboard until the "MODULATE"
filename appears and press < Enter/Return > on the keyboard

[MODE]
[PLAYBACK]
Press [RUN].

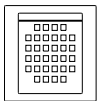

2. Press
[Triple Trace]
[A]



3. Press
[HOME]
[DISPLAY]
[DSPLY TYPE]
[NEXT]
[NEXT]
[HISTOGRAM] (You may have to press [Y Auto Scale] on the button box.)



4. Press
[B]



5. Press
[PDF] (You may have to press [Y Auto Scale] on the button box.)



6. Press
[C]



7. Press
[CDF] (You may have to press [Y Auto Scale] on the button box.)

These three display types present data in the amplitude domain.

Histogram data shows how the amplitude of the input signal is distributed between two voltage values during a series of baseband measurements (averaged or non-averaged). Histograms give an indication of how often a signal stays at a particular amplitude level. The total number of samples accumulated for the histogram (histogram length) is specified using the # AVERAGES function. For example, for a histogram length of 10 and 801 HISTGRM BINS, (10 X 801 X 2.56) samples are accumulated for the histogram. Histograms are often used to determine the statistical properties of noise. You can also display a histogram in map form ([HIST MAP]) or in color map form ([HIST CMAP]).

Probability Density Function (PDF) is a statistical measure of the probability that a specific level occurred. It is similar to histogram data, except that the PDF is a normalized version of the histogram. The analyzer calculates PDF by multiplying the number of averages by the number of points in the time record and dividing the histogram by this value. The probability (from 0.0 to 1.0) of an input signal falling between two display points is equal to the integral of the curve between these two points.

Cumulative Density Function (CDF) shows the probability that a level equal to or less than a specific level occurred. It is useful for checking for dc offsets with symmetrical signals. It is calculated by integrating PDF results.

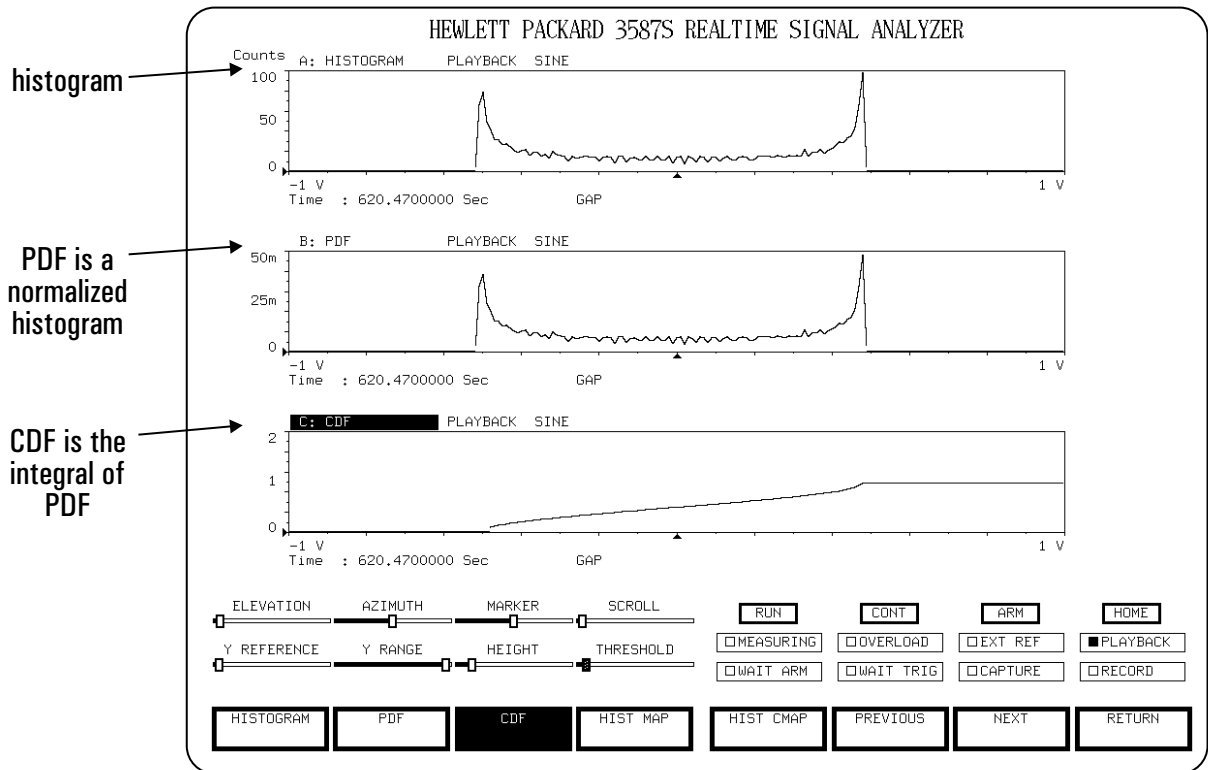

Titles and Annotation

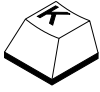

1. Press
[HOME]
[DISPLAY]
[ACTIVE TRACE]
[A], [B] or [C] (each trace has its own annotation field)
[ANNOTATION SETUP]
Toggle to [ANNOTATION ON]
[FIRST LINE] and type up to 80 characters on the keyboard such as “Signal
characterization” and press [Return].
2. If you want to enter a second line, press
[SECOND LINE] and type up to 80 characters on the keyboard.
3. Press
[TITLE]
4. Type up to 80 characters on the keyboard such as “Analysis for Friday, October 30”
and press [Enter/Return].

The following figure is an example. For longer entries, arrows appear at each end of the entry line to indicate there is more text. Refer to the screen annotation fields to see the full entry. (Make sure you have turned the annotation on first). Use the backspace, delete and insert keys on the keyboard to edit.

There is also a vertical annotation field along the left side of each trace. These are convenient for landscape printouts.

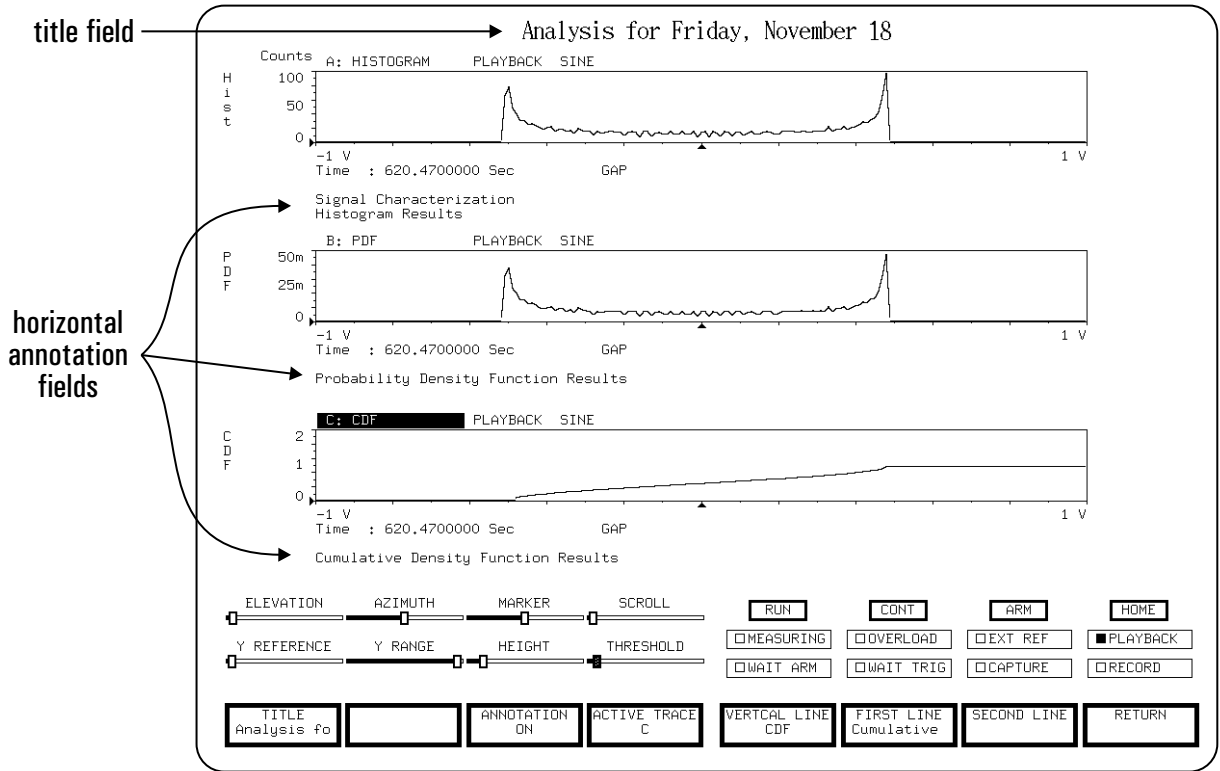

Printing

1. Make the appropriate printer connections as shown in the figure which follows. See the Hardware Installation Note for details.
2. Turn the printer on, make sure it has paper and is ready to print.
3. Make sure the display is set up exactly as you want it printed.
4. To print your own title or annotation, complete the steps in “Titles and Annotation” on page 50.
5. Press
[HOME]
[HARDCOPY]
[PRINTER SETUP]
6. Press
[PRINT MODE] and choose from the following to specify the information to print:
 - a. [TRACE ONLY] prints the displayed data, grid and associated annotation for the active trace(s).
 - b. [FULL SCREEN] prints the entire display contents. This includes the instrument controls and indicators at the bottom of the display.
 - c. [TRACE+STATE] prints the full screen contents and appends the instrument settings used to take the data at the bottom of the printout.Press [RETURN]
7. Press
[PRINTER TYPE]
[LASERJET PORTRAIT] or [LASERJET LANDSCAPE]
(portrait prints vertically, landscape prints horizontally)
[RETURN]
8. Make sure [PRTR STATUS] is toggled to [ENABLE]. If [UNAVAILABLE] appears, the system is not recognizing the selected printer type. Check that the printer is properly connected.
9. Press
[RETURN]
[PRINT SCREEN] to print the specified information to the printer.

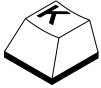

You can also print the following special items by pressing the following in the last step.

[PRINT MENU SYSTEM] prints the current keyboard softkey menu structure.

[PRINT STATE] prints the current instrument state.

[PRINT HELP TEXT] prints the entire help index.

If you are printing a color map or spectrogram to an HP LaserJet, you may want to change to a gray scale before you print. See “Map Colors” on page 34.

If your printer is not an HP LaserJet, you must use the HP 35687B Option AGG Customization Software to print the data to a file, and then use a conversion program to convert the file for compatibility to your printer. See “Printing to other types of printers” in the *HP 35687B Installation, Customization, and Programming Reference* for more information.

Note

If the printer does not start printing:

Check that the printer is connected to power, turned on, properly connected to the VXI CPU module, and has paper. You may need to refer to the printer's operating manual for special instructions about printer selections.

Re-check the [PRTR STATUS] (should be toggled to [ENABLE]) and that the correct printer is selected under [PRINTER TYPE].

Check /opt/hp3587s/README.print for more details regarding printer setup.

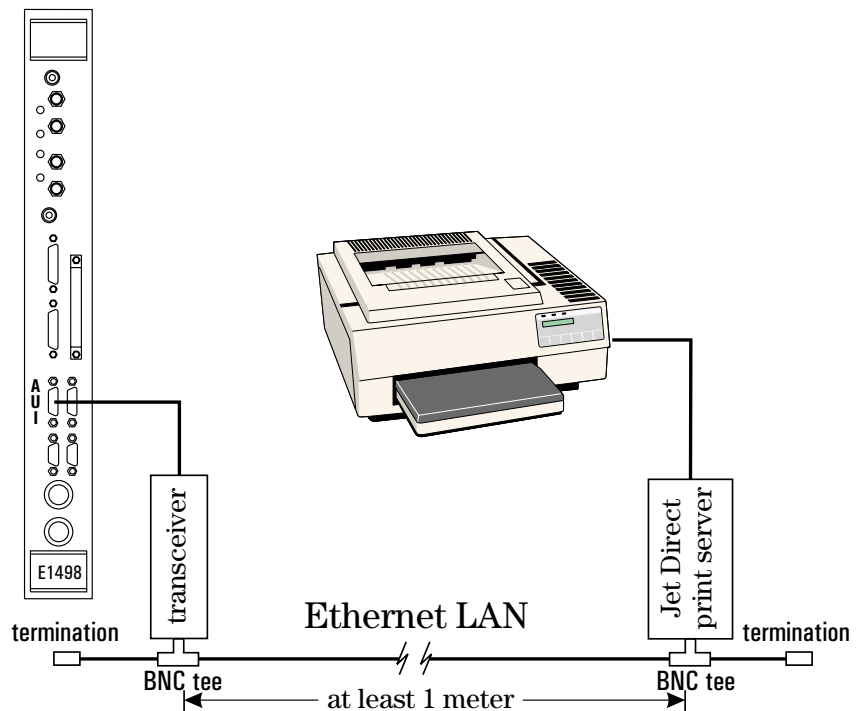

Batch Printing

You may “collect” a number of displays to print and, later, print several sets of data at a later time as follows:

1. Perform the steps in “Printing”, except in step 8 toggle [PRTR STATUS] to [DISABLED].
2. Repeat step 9 each time you want to print the display.
3. When you are ready to do the batch printing, toggle [PRTR STATUS] to [ENABLE]. Each set of data will print one after the other.

With the printer disabled, each set of print data is sent to the printer spooler where it remains until the printer is enabled again. Since printing can be time consuming, this is useful for batch printing several files at a more convenient time.

Making Measurements

This chapter shows how to set up the input hardware and the signal processor to make measurements.

Introduction

This chapter discusses using parameters in the measurement block. This consists of parameters in the ADC and DSP block, as shown in the following figure.

The HP 3587S is a Fast Fourier Transform (FFT) analyzer. The basics of FFT signal analysis are explained in the book *Spectrum & Network Measurements* by Robert A. Witte (HP P/N 5960-5718).

The analog-to-digital converter (ADC) performs the following functions:

- filters the analog signal to block frequencies above $f_s/2$
- samples the signal (analog in, digital out)
- for zoom measurements, it mixes the digital data streams (real and imaginary) with a digital sinusoid as is done in IF downconversion
- performs decimation filtering to reduce the span

The digital signal processor (DSP) performs the following functions:

- performs decimation filtering to provide narrower frequency resolution
- implements the windowing function(s) to control leakage
- calculates the selected measurement results
- performs selected averaging function

The CPU performs all the display functions

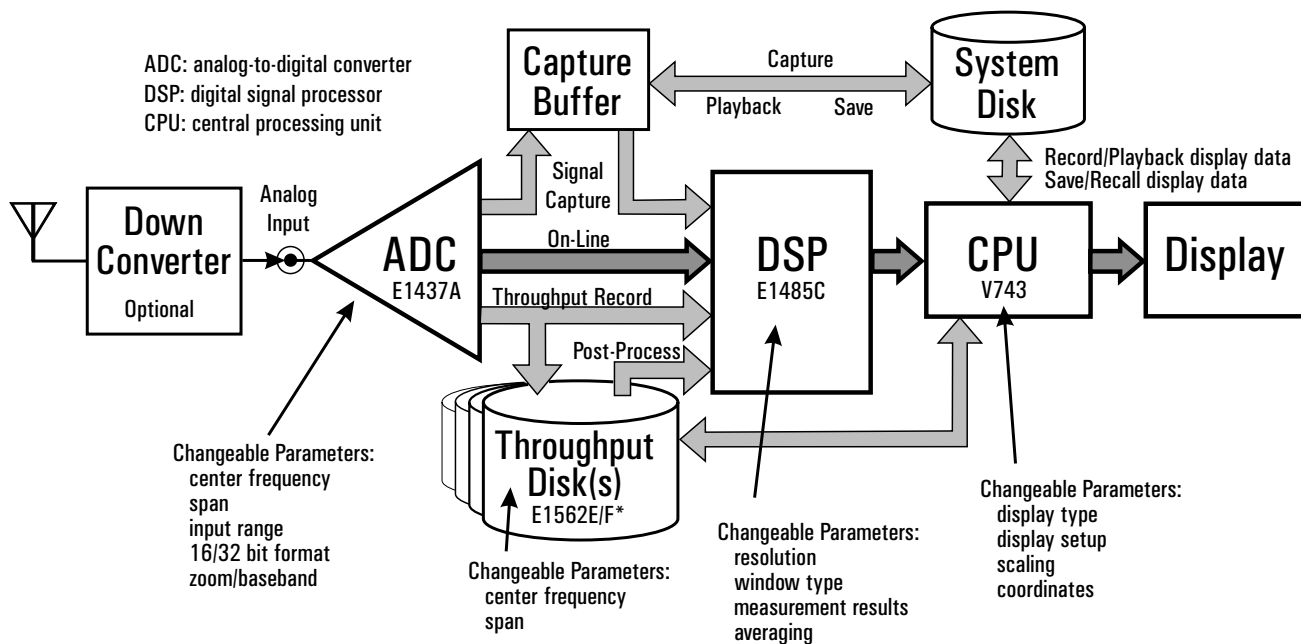

*Option ATR hardware
 SCSI disks connected
 together with external
 (front-panel) cables.

Presetting the System

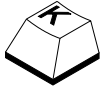

1. Press
[HOME]
[SYSTEM]
[PRESET]
2. Press
[COLOR SETUP],
[DISPLAY SETUP],
[MEASUREMENT SETUP],
[FRONT END HARDWARE], or
[ALL] to reset the indicated portion of the system to its default values. See Appendix C (page 113) for preset parameters settings.

Preset is useful for setting up a new measurement because it puts part or all of the system in a known state. The preset occurs immediately after you indicate which type of preset you want performed.

See Appendix C (page 113) for a list of preset functions and their default values. For each preset mode except ALL, currently displayed data is not lost.

When you power up the system, all values are set to their preset value. Therefore, before you shut the system down, you should save any data or instrument states you want to use later.

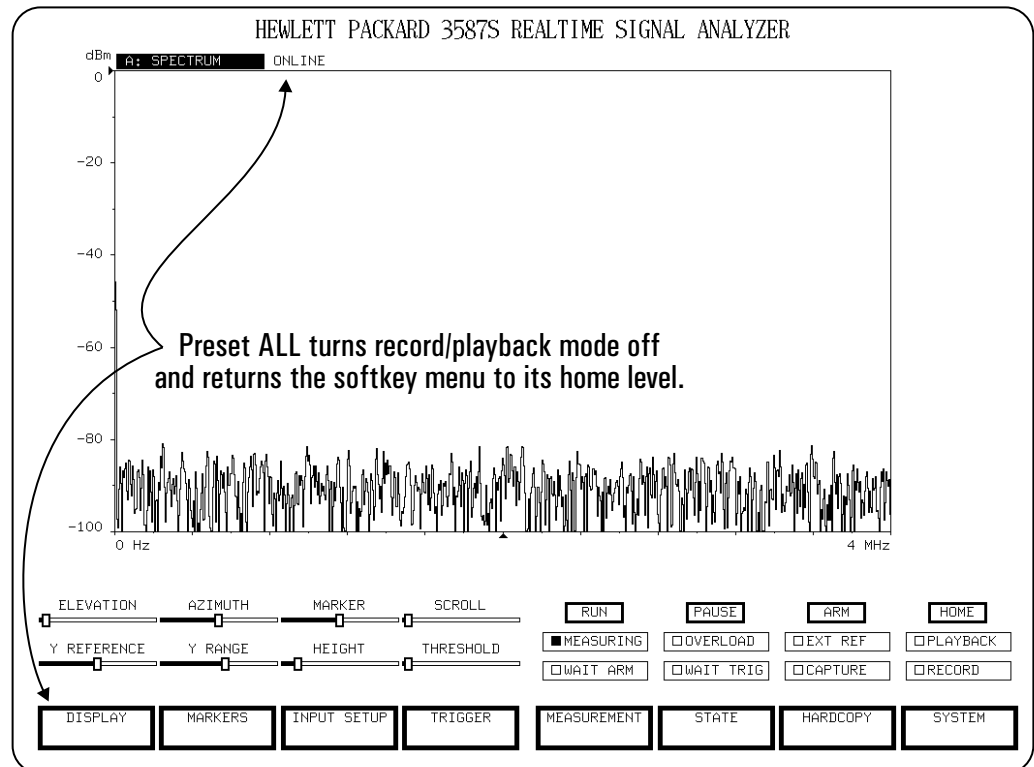

Online Measurements

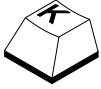

1. Connect a 1 MHz, 1 V_{rms} sine wave to the HP E1430A/E1437A input module as shown in the diagram on the next page.
2. Press
[HOME]
[SYSTEM]
[PRESET]
[ALL]

Notice the “ONLINE” indicator above the trace which means the displayed data is coming directly from the input module.

If the input range setting is the default value, the red overload indicator shows that this 1 V_{rms} signal overloads the input.

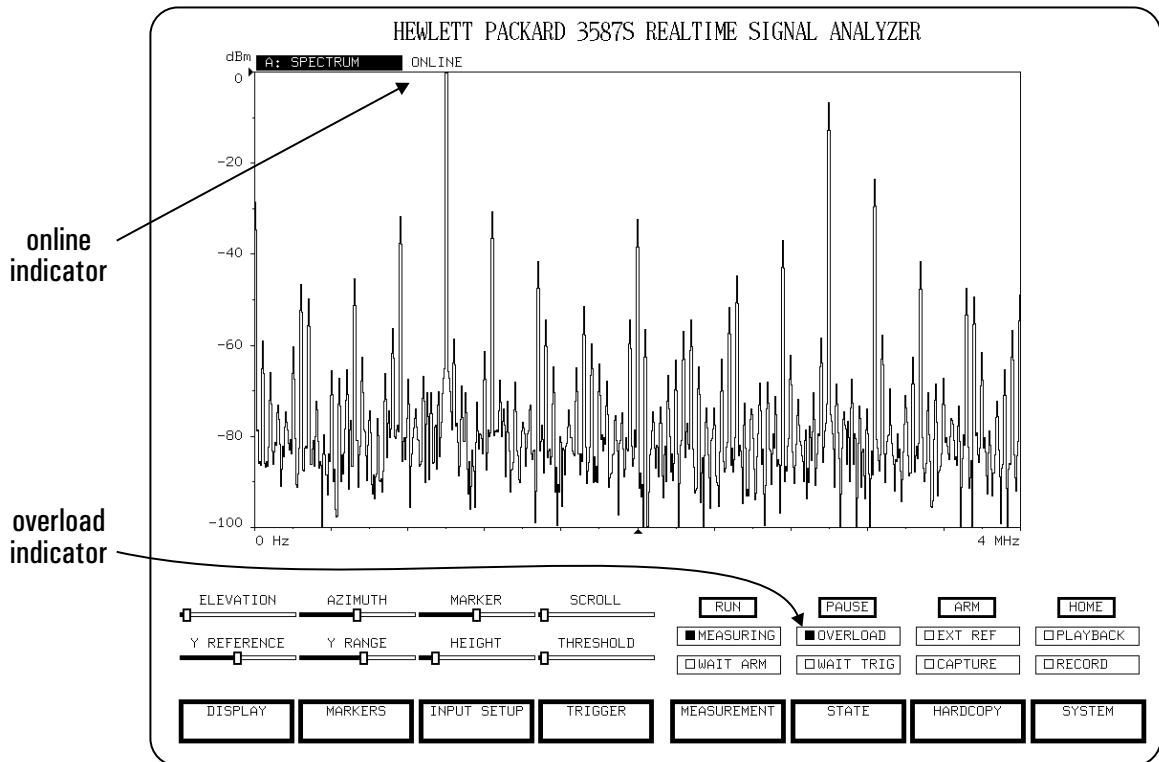

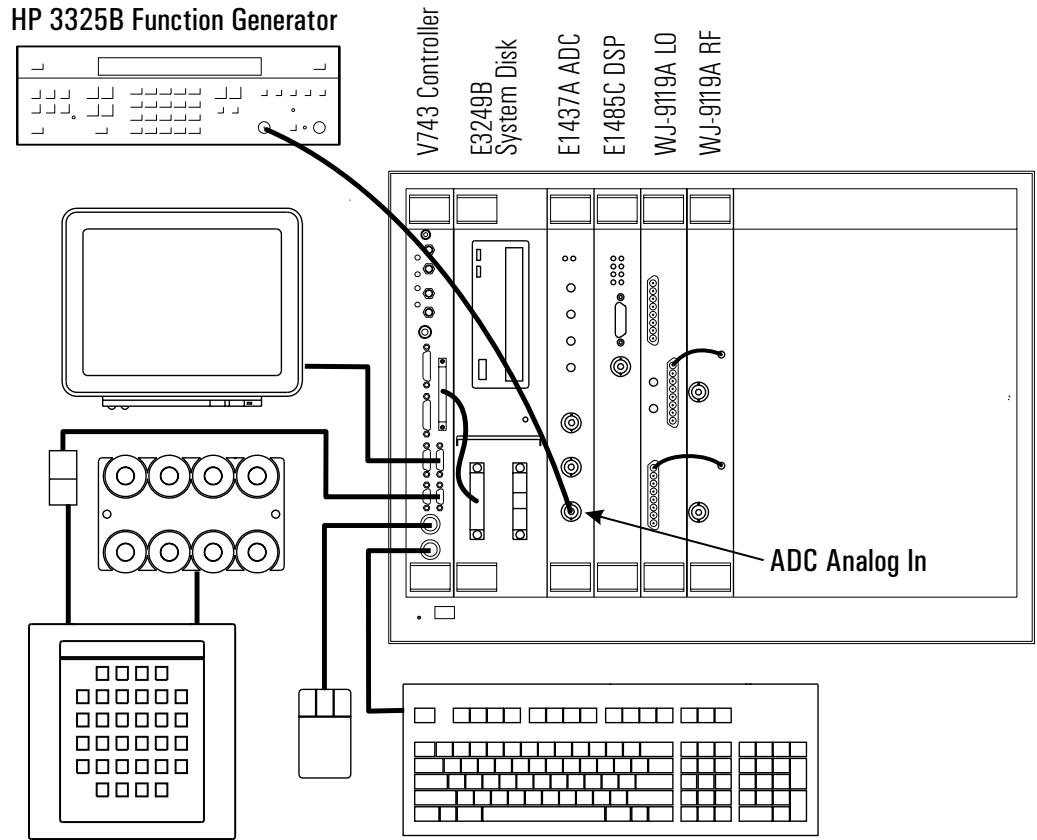

Connecting a signal generator to the input of the ADC module.

Input Range

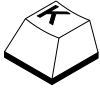

1. Before you begin, complete the steps in "Online Measurements" (page 58).
2. Press
[Monitor] and notice the new slide bar controls on the display.

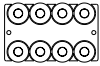

3. Turn
[INPUT RANGE]

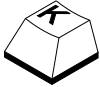

4. Press
[HOME]
[INPUT SETUP]
[AUTO RANGE] and notice the red overload indicator is now off.

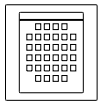

5. Press
[Auto Scale]

You can set the input range manually (as in step 3) or automatically (as in step 4).

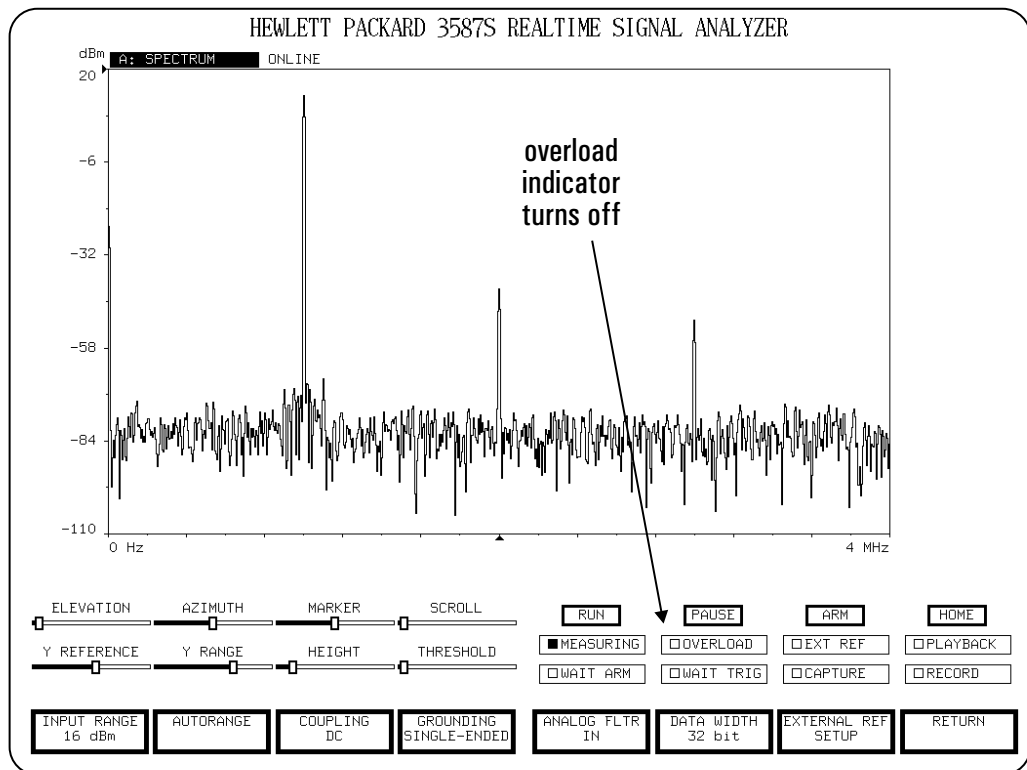

Frequency Span

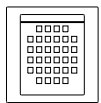
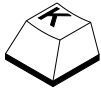

1. Connect a 1 MHz, 0 dBm signal to the E1430A/E1437A.
2. Press
[HOME]
[SYSTEM]
[PRESET]
[ALL]
3. Press
[Monitor]
4. Turn
[SPAN FREQ] to the left until the stop frequency is the desired value. For the pictured example, the stop frequency is 2 MHz.

When you decrease the frequency span, the length of the time data record increases—the exact length of the time data record (measured in seconds) is $(\# \text{ LINES} - 1)/\text{span}$. Therefore, the smaller the frequency span, the lower the measurement speed. The time record length and the resolution are simply different ways of expressing the same information.

Overlap processing can help to compensate for slower measurement speed. See “Overlap Processing” on page 66 for more information.

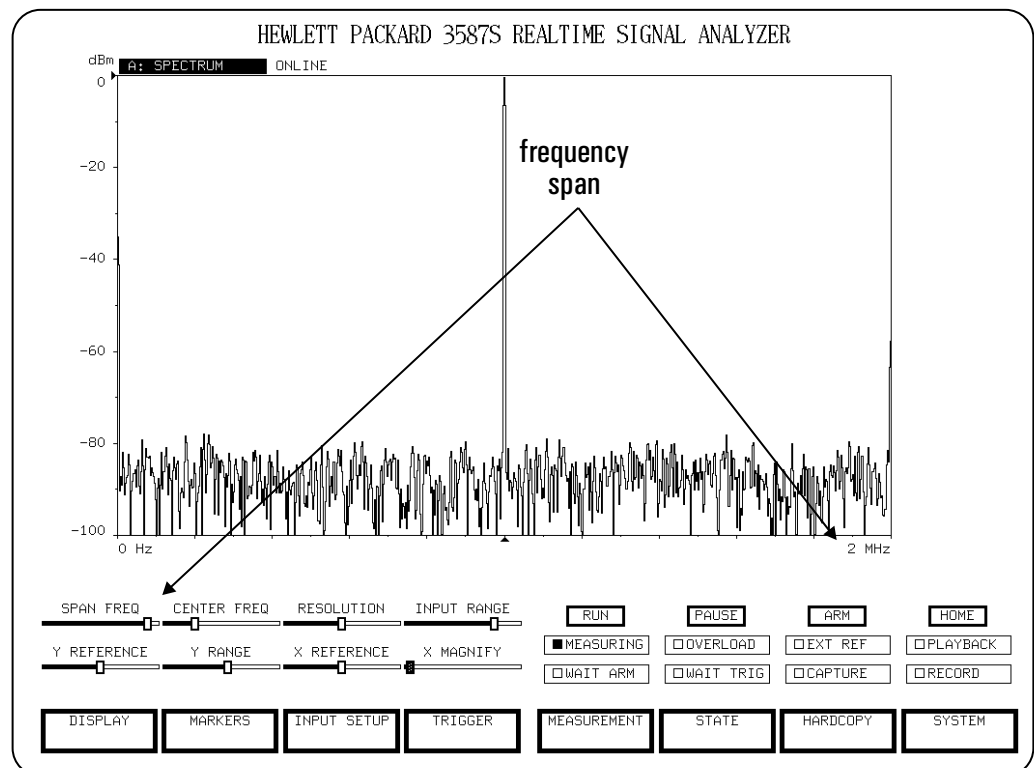

Window Functions

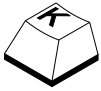

1. Connect a 1 MHz, 0dBm signal to the E1430A/E1437A.

2. Press
[HOME]
[SYSTEM]
[PRESET]
[ALL]

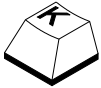

3. Press
[HOME]
[MEASUREMENT]
[MEASUREMENT PARAMETERS]
[FREQ WINDOW]
[FLATTOP] and notice the signals appear more wide, illustrating the window's frequency resolution performance.

4. Select the window best suited for your measurement. Each window type offers different performance necessary for various types of measurements. The following table will help you select the appropriate window for your measurement.

A window is a time-domain weighting function applied to the input signal. It filters out signals that are not periodic within the input time record. Depending on the window, the analyzer attenuates certain parts of the input time record, to prevent "leakage"—a smearing of energy across the frequency spectrum, caused by transforming signals that are not periodic within the time record.

Window Summary

	Leakage Performance	Highest Sidelobe (dB)	Sidelobe Fall Off (dB/decade)	Frequency Resolution	Noise Equiv. BW Factor ¹	Max Amplitude Error ²	Uses
Uniform	Poor	-13	-20	Good	1.00	3.92 dB	Self-windowing & transient data
Hann	Relatively Good	-32	-60	Relatively Good	1.50	1.42 dB	General purpose
Gausstop	Good	-125	-20	Good	2.22	0.68 dB	High-dynamic-range measurements
Flat Top	Good	-93	-20	Poor	3.82	< 0.01 dB	Amplitude calibration
Blackman	Relatively Good	-58	-60	Relatively Good	1.73	1.10 dB	General Purpose
Gaussian	Good	-127	-60	Good	2.14	0.63 dB	Phase Noise Measurements

1. Window functions include energy from bins which are adjacent to the window. Noise Bandwidth is the effective width of the window. Calculate it using the following formula:

$$\text{Noise Equivalent Bandwidth} = (\text{Resolution of measurement}) (\text{Noise Equivalent Bandwidth Factor})$$

2. The maximum amplitude error occurs when a signal is at the edge of the bin.

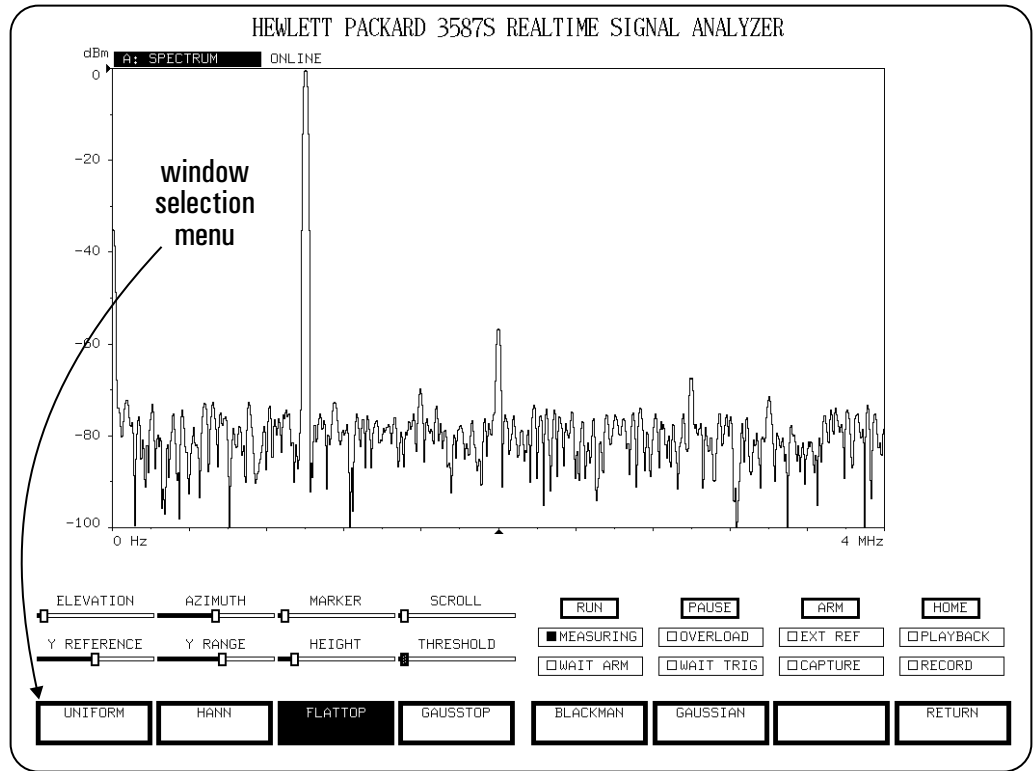

Windows menu

Measurement Resolution

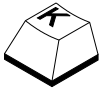

1. Connect a 1 MHz, 0dBm signal to the E1430A/E1437A.

2. Press
[HOME]
[SYSTEM]
[PRESET]
[ALL]

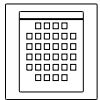

3. Press
[Monitor]



4. Turn
[RESOLUTION] and notice the changing number of data points (sometimes called number of lines) on the display.

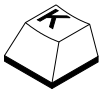

5. To find out the resolution of the current measurement, press
[HOME]
[MEASUREMENT]
[RESOLUTION SETUP]

6. Notice the number below [RESOLUTION]. This number represents the number of Hz between each point in the data record.

Three resolution parameters appear under [RESOLUTION SETUP]. Each is a different way to express resolution. [NUMBER LINES] is often used to specify resolution for frequency measurements because the number of lines are the number of points shown.

[RESOLUTION] represents the frequency span divided by the number of lines.

[TIME LENGTH] is the total time used to take a data record. It is a convenient way to specify resolution for transient measurements. [TIME LENGTH] is proportional to frequency resolution and inversely proportional to frequency span.

Increasing the resolution is useful for resolving closely spaced signals. However, the greater the resolution, the longer the time record required. For example, an 801-line spectrum measurement with a 976 Hz span requires a 0.819 second time record. A 3201-line measurement of the same 976 Hz span requires a 3.2 second time record. This relationship is independent of processing speed.

If the number of lines specified *exceeds* the number of pixels available for the display, a compression algorithm is used for display purposes. This algorithm displays the minimum and maximum values over intervals, which results in a waveform that is representative of the data. The marker reads out all points in the data record independent of the compression/expansion used to display the data. You can also use [X MAGNIFY] to look at all of the points. When the number of lines specified is *less* than the number of pixels available for the display, a line is drawn between data points.

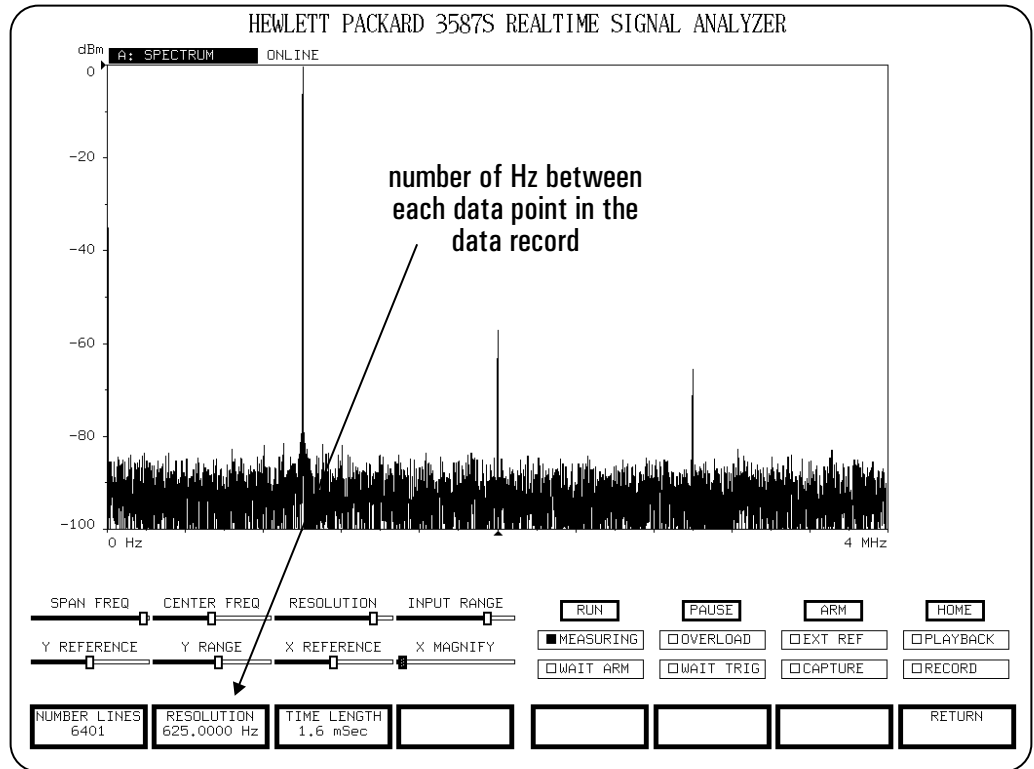

Current resolution setting is displayed on menu button.

Overlap Processing

Overlap processing is another characteristic of the FFT analyzer. See page 120.



1. Connect a 1 kHz, 0dBm signal to the E1430A/E1437A. Adjust the frequency span to 5 kHz or less. See “Frequency Span” on page 61.
2. Press
[Auto Scale]
3. Press
[HOME]
[MEASUREMENT]
[MEASUREMENT PARAMETERS]
[OVERLAP]
Type 50 and press [Return] on the keyboard.

The measurement speed increases between a 0% overlap and 50% overlap measurement.

Use overlap processing to increase the measurement speed when you are using narrow spans. Smaller spans usually mean the time record length is longer than the FFT processing time. To get maximum efficiency from the FFT processor, you can overlap the time records so that the FFT processor uses data from both previous and current time records.

If the [TRIG MODE] is not [FREERUN], overlap processing is not used.

The amount of overlap possible varies with the frequency span as shown in the following table. For wide spans (with short time records), little or no overlap is possible—the time record is small compared to the time it takes the analyzer to process the time record. For narrow spans (with long time records), considerable overlap is possible—the time record is long compared to the time it takes the analyzer to process the time record.

Span ¹	Allowable Overlap ²
8 MHz	—
4 MHz	—
2 MHz	—
1 MHz	0%
500 kHz	0% or 50%
250 kHz	0% or 50%
125 kHz	0% or 50%
250 Hz to 62.5 kHz	0% to 100% ³

¹ If Signal Capture mode is on, overlap is independent of span.

² Overlap processing is not allowed if the resolution is set to 1280 lines.

³ 100% overlap means a new FFT is calculated each time a data point is added to the block.

When the analyzer cannot perform the specified overlap processing, the “GAP” indicator appears and data is processed in block mode (with no overlap).

Real-time Bandwidth is a term used to characterize the performance of an FFT analyzer. The real-time bandwidth is the frequency span at which the processing time *equals* the time record length and no data is lost but no overlap processing is possible, either.

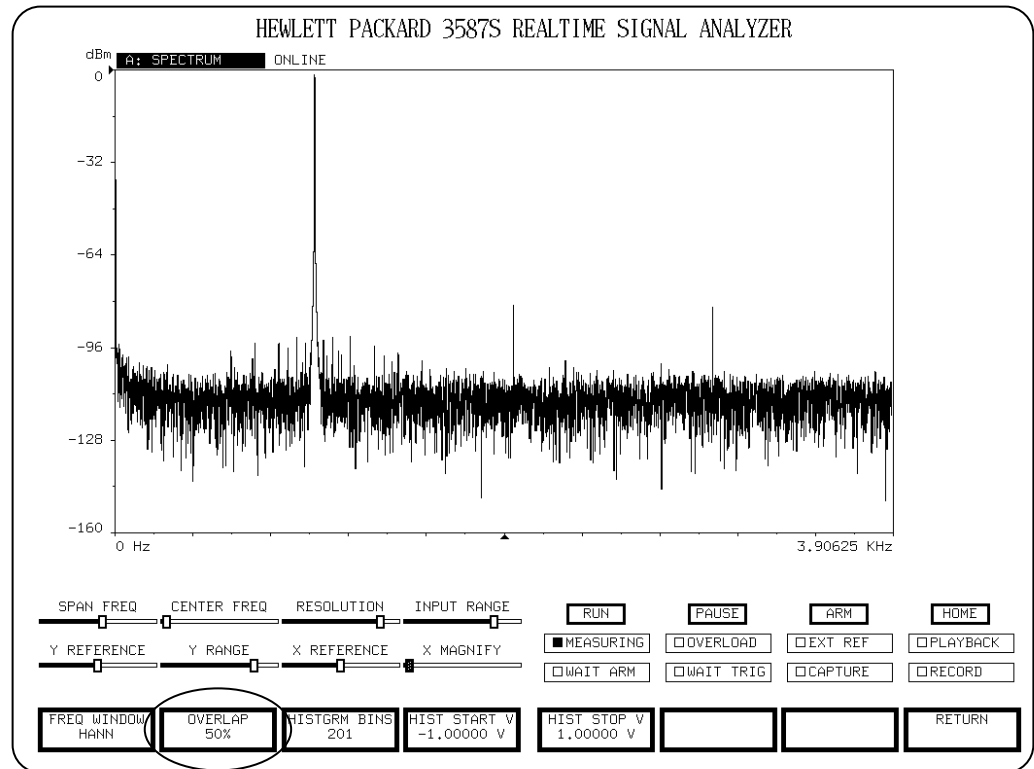

Current overlap setting is displayed on menu button.

Zoom Measurements

Zoom measurement or *band-selectable analysis* allows a measurement with a start frequency greater than 0 Hz (i.e., non-baseband). The following exercise demonstrates how to do this with the HP 3587S.

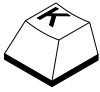

1. Before you begin, complete the steps in “Frequency Span” (page 61).

2. Press
[HOME]
[MEASUREMENT]
[FREQUENCY SETUP]
Toggle to [ZOOM MODE: ON]

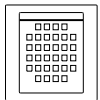

3. Press
[Monitor]

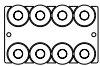

4. Turn [SPAN FREQ] to the left to reduce the frequency span.

5. Turn
[CENTER FREQ] until the signal is at the center of the display or enter the frequency of the signal of interest using the numeric keypad and press [Return].
6. If necessary, re-center the signal (repeat step 4) as you reduce the span frequency.

With [ZOOM MODE] turned off, the analyzer takes a baseband measurement which has a start frequency of 0 Hz. With [ZOOM MODE] turned on, the start frequency can be greater than 0 Hz. This allows you to examine a frequency range centered on a signal with a better resolution than would be possible with a baseband measurement.

Zoom filtering creates complex data, which can display zoomed time data in real and imaginary coordinates. See “Complex Coordinates” on page 72 for more information.

Data cannot be re-zoomed during playback or signal capture playback because the zoom filtering is done in the ADC module when the data is collected. To look at a different portion of the spectrum, zoomed measurements require new measurement data. See “Playing Back Captured Data” on page 86 for more information.

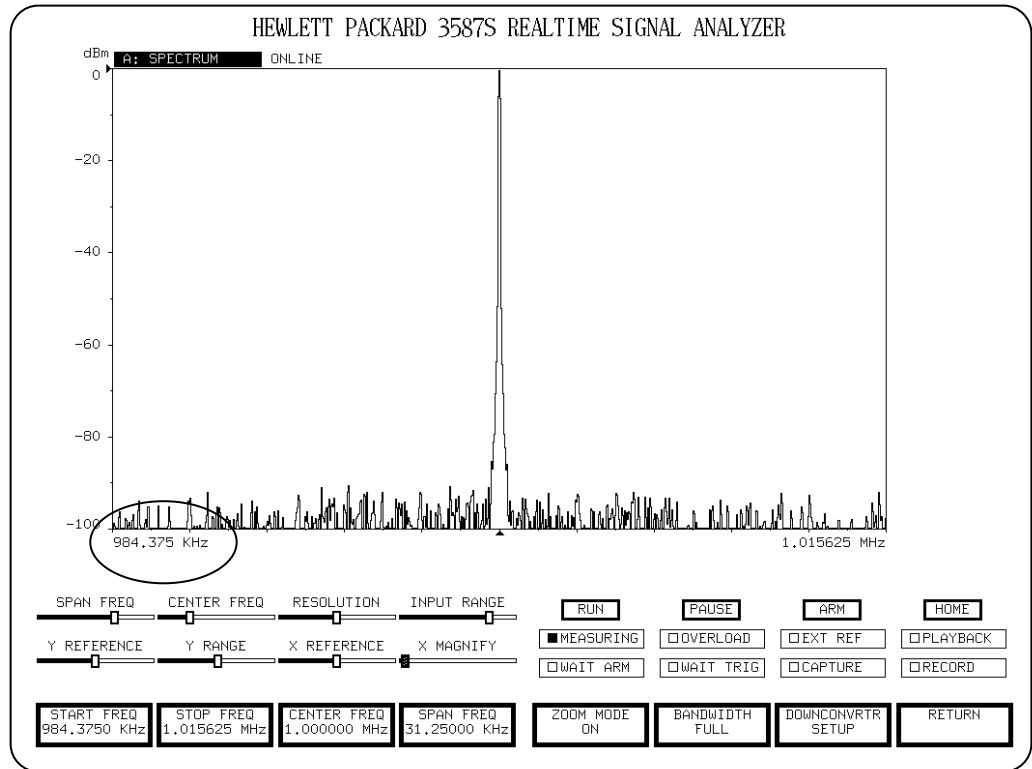

Y-Axis Coordinates

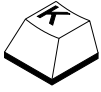

1. Press
[HOME]
[DISPLAY]
[COORDINATES]
[Y-AXIS COORD]
[MAG (lin)]

The [MAG (lin)] coordinate displays all points on the y-axis in a linear fashion. The marker and display annotation read out in linear units, meaning they simply give the number of units (according to the units selections). The following table contrasts the coordinate types. See the Display and Measurement Cross-Reference in Appendix B (page 109) for information about which coordinates are available for each display type.

Coordinate Comparison

	Data is Displayed	Marker and display annotation read in:
MAG (lin)	linearly	linear units (i.e., Vpk)
MAG (log)	logarithmically	linear units (i.e., Vpk)
dB	logarithmically	logarithmic units (i.e., dB)
dBm	logarithmically	power units (i.e., Vpk)
REAL ¹	linearly	linear units (i.e., Vpk)
IMAG ¹	linearly	linear units (i.e., Vpk)

¹ See "Complex Coordinates" on page 72 for more information on these coordinates.

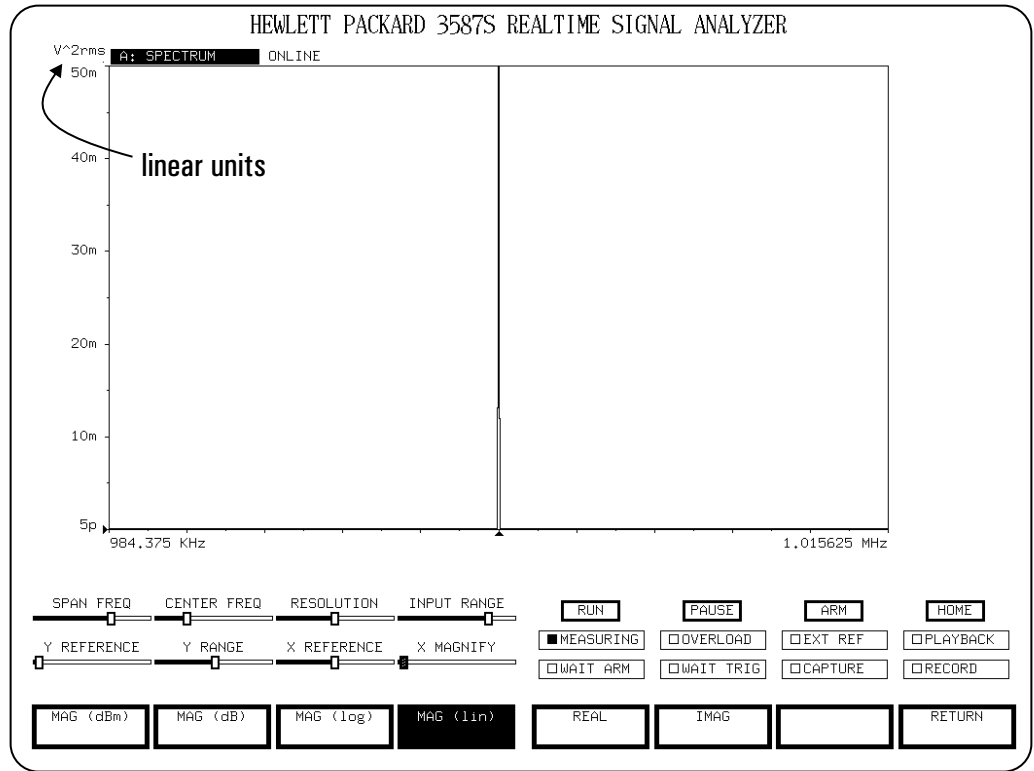

Y-axis coordinates menu

Complex Coordinates



1. Complete the steps in "Frequency Span" (page 61) except change the signal frequency to 500 kHz.

2. Press
[FREQUENCY SETUP]
Toggle to [ZOOM MODE: ON]
[CENTER FREQ] (enter 500.5 kHz)
[SPAN] (125 kHz)



3. Press
[HOME]
[MEASUREMENT]
[MEASUREMENT RESULTS]
Toggle to [TIME ON]

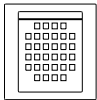

4. Press
[Run]
[Dual Trace] (displays 2 traces)
[All Traces] (makes all traces active)
[Time]
[A]



5. Press
[HOME]
[DISPLAY]
[COORDINATES]
[Y-AXIS COORD]
[REAL]

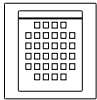

6. Press
[B]



7. Press
[IMAG]

Real and imaginary coordinates can only be selected if the [TIME] measurement result is turned on and the display type is [TIME], [TIME MAP] or [STRIP CHART].

For time waveforms taken using a baseband span, a time trace with real coordinates gives the complete representation of the waveform and the imaginary part is equal to zero. Therefore, you should select [REAL] when viewing baseband time domain data.

For time waveforms taken in with [ZOOM MODE] turned on, a time trace with real coordinates can be hard to interpret. The zooming algorithm computes complex data and multiplies the time waveform by a cosine function. Therefore, the frequency of this cosine function equals the center frequency used for the zoom measurement. The result is a frequency-shifted time trace. For example, if you input 2V dc, the real trace displays a cosine wave. If you input a 2V peak sine wave, the in-phase portions of the cosine wave amplify the amplitude of the input time waveform and the out-of-phase portions of the cosine wave would subtract from the amplitude of the input time waveform. This cosine multiplication also causes the imaginary part of the time waveform to appear to have a non-zero value.

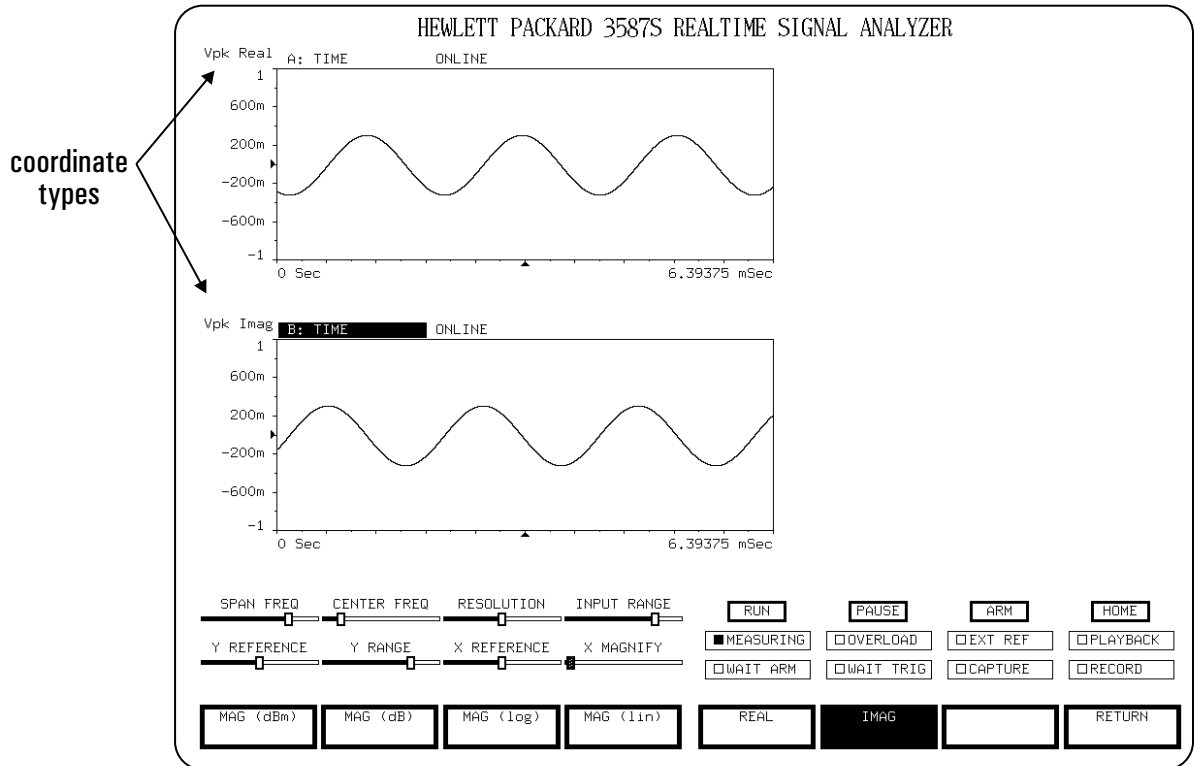

coordinate
types

Top trace is real data, bottom trace is imaginary.

Averaging

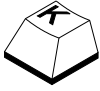

1. Complete the steps in "Frequency Span" (page 61).
2. Press
 [HOME]
 [MEASUREMENT]
 [AVERAGING SETUP]
 [# AVERAGES]
 Type 15 and press [Enter/Return]
 [AVERAGE MODE]
 [RMS]
 [RETURN]

When 15 data records are obtained, the average results are displayed. Notice the peak excursion of the noise is reduced. The table which follows outlines the other average types available. Note that PEAK and Nth modes are not really average functions but use the [# AVERAGES] function for their purpose.

Averaging Summary

Type	Definition	Advantages
RMS	Takes the sum of all corresponding y-axis values of each processed data record and divides each value by the [# AVERAGES].	Good for analyzing stationary data. Improves statistical accuracy. Display upgrades when the [# AVERAGES] are processed.
Exponential	A "moving" average with each record being weighted according to the time at which it was acquired - the earlier the record, the less significance it has in the resulting average. It is calculated using the equation: $[(1/E \text{ (new)}) + ((E-1)/E \text{ (old)})]$; where E = EXPONential FACTOR which lets you change the weighting.	Good for analyzing non-stationary data. Slightly improves statistical accuracy.
Peak	Maintains the maximum amplitude at each x-axis position and updates the display when the specified [# AVERAGES] has been taken. (Note that this is not really an average function.)	Lets you detect transient signal and dominant frequency components that vary with time.
Nth	Updates the display after N data records are acquired, where N is specified by the [# AVERAGES] function. The displayed data record is <i>not</i> averaged.	Good for data reduction which is sometimes desired when recording data.

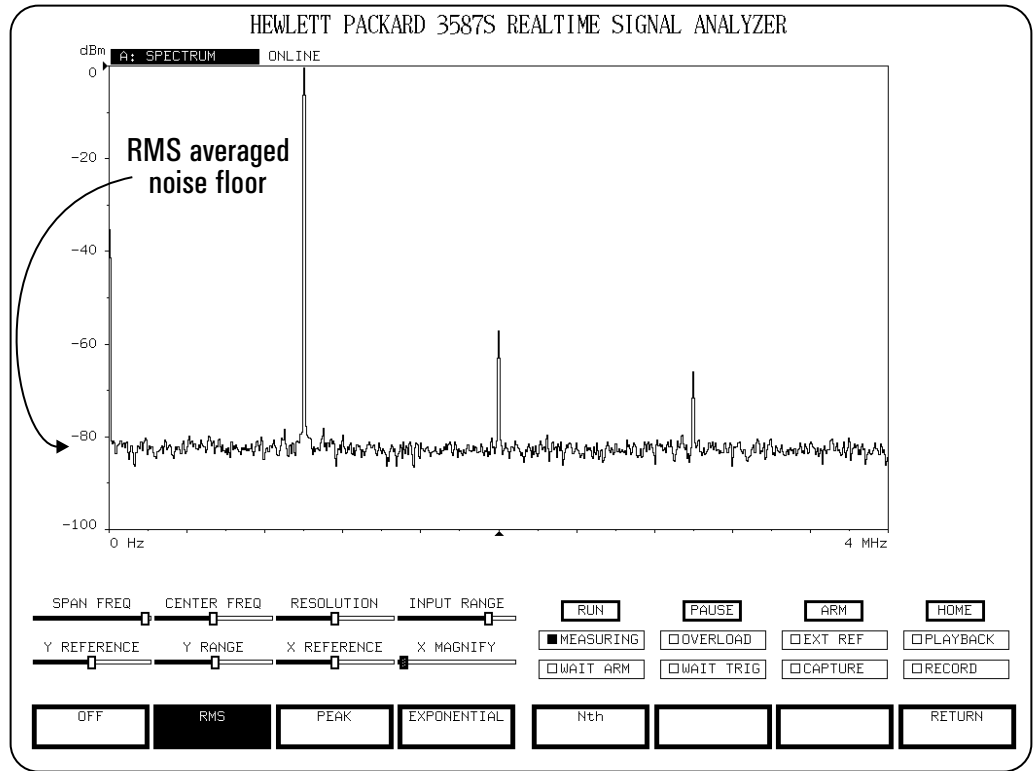

Averaging functions enhance the display information.

Trigger Conditions

1. Complete the steps in “Frequency Span” on page 61.
Zoom in on the 1 MHz signal used in the example and select a 500 kHz span. See “Zoom Measurements” on page 68.



2. Press
[Run]
[Dual Trace]
[A]
[Spectrum]
[B]
[Time]



3. Press
[HOME]
[MEASUREMENT]
[MEAS RESULTS]
Toggle to [TIME ON]
[HOME]
[TRIGGER]
[TRIG MODE]
[LEVEL]
[RETURN]
[TRIG LEVEL]
Type 25 and press [RETURN] (25% FS = 25% of the full scale input range)

4. Reduce the output level on the signal generator and notice that the measurement stops because the input signal level is now below 25% of the full scale input range. Increase the output level again and the measurement resumes.



5. If the triggering signal is not a steady-state signal, you can use a magnitude trigger as follows.
[TRIG MODE]
[MAGNITUDE]
[RETURN]
[TRG MAG LVL]
Type -12 and press [RETURN] (-12 dBFS = 12 dB below the full scale input range)

Trigger Modes

[FREERUN] ignores the trigger conditions and takes a measurement as soon as the previous data is acquired and processed.

[LEVEL] triggers a measurement when the input signal level exceeds the specified percentage of the full scale input range.

[MAGNITUDE] triggers a measurement when the instantaneous input signal power passes through a specified power level within the current span setting. A trigger does not occur if the signal amplitude is constant or if the signal is at the edge or outside of the current span settings. For positive slope triggers, the amplitude must at least pass from 1.5 dB below the trigger point to the trigger point. For negative slope triggers, the signal amplitude must at least pass from 1.5 dB above the trigger point to the trigger point. In the example, when the 1 MHz signal passes through a level 12 dB lower than the full scale input range, a measurement is triggered.

[EXTERNAL] acquires data when the signal applied to the EXT TRIG connector on the HP E1430A/E1437A Input Module meets the trigger conditions.

Other Trigger Functions

Trigger Slope — triggers on the positive or negative slope of the input signal.

Trigger Delay — starts a measurement when the specified number of sample points (N) before or after the trigger conditions are met. A negative value is a pre-trigger and a positive value is a post-trigger. If you want a measurement to start before an event by a specific amount of time (t_p , in seconds), you can calculate N using the following equation.

$$N = t_p \times \text{Sample Rate}$$

where: Sample Rate = [SPAN FREQ] 2.56

Trigger delay has a resolution of 4 samples.

Max trigger delay (pre or post) is 1 Megasamples

Arm — takes a measurement each time the trigger conditions are met (AUTO) or take only one measurement when the trigger conditions are met (MANUAL). See “Signal Capture” (page 84) for an example of manually arming the trigger.

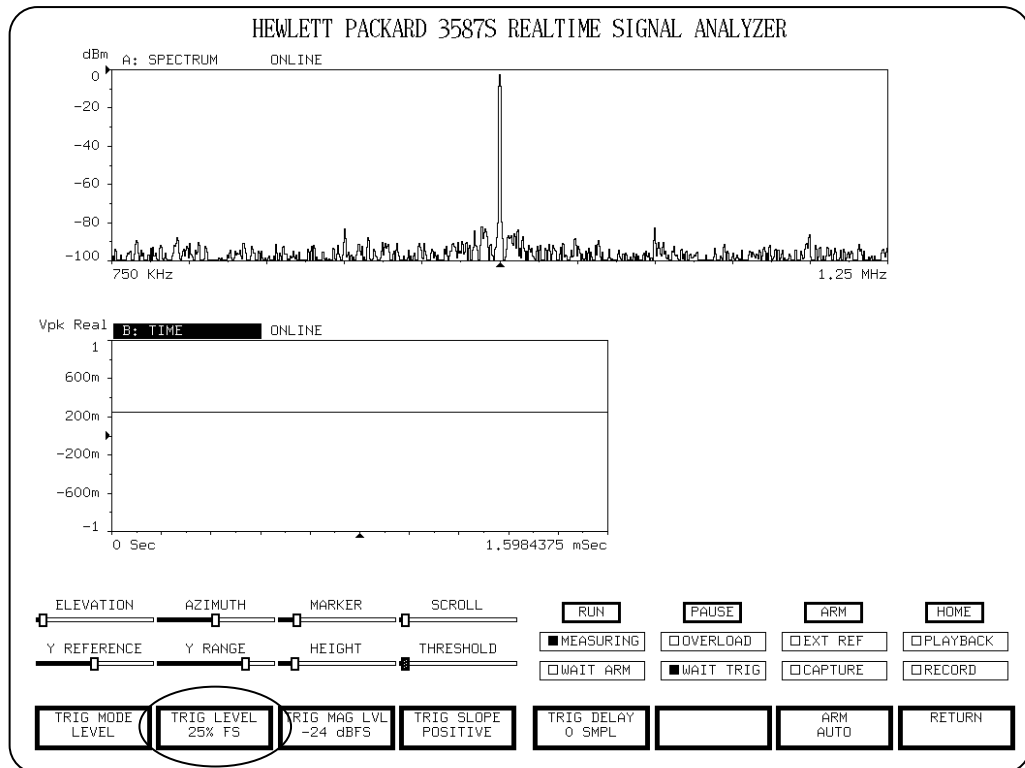

A signal level > 25% FS (full scale) triggers a measurement.

Collecting Data

This chapter discusses several methods to store and retrieve display data, captured measurement data, and instrument states. It also outlines the file management features.

Introduction

There are three types of data that can be collected and stored on disk:

Signal capture data is unprocessed measurement data captured in RAM.

Throughput capture data (option ATR) is unprocessed measurement data captured directly to a throughput disk system.

Display data is processed measurement data, suitable for display.

There are four ways to collect this data:

Save *signal capture* data to the *system* disk

Record throughput capture data to the *throughput* disk (option ATR)

Save a block of display data to the system disk

Record display data continuously to the system disk

The data type and collection method affects how the data can be post-processed as well as how much data can be collected. The following figure shows the system configuration, data processing, and information flow discussed in the following topics.

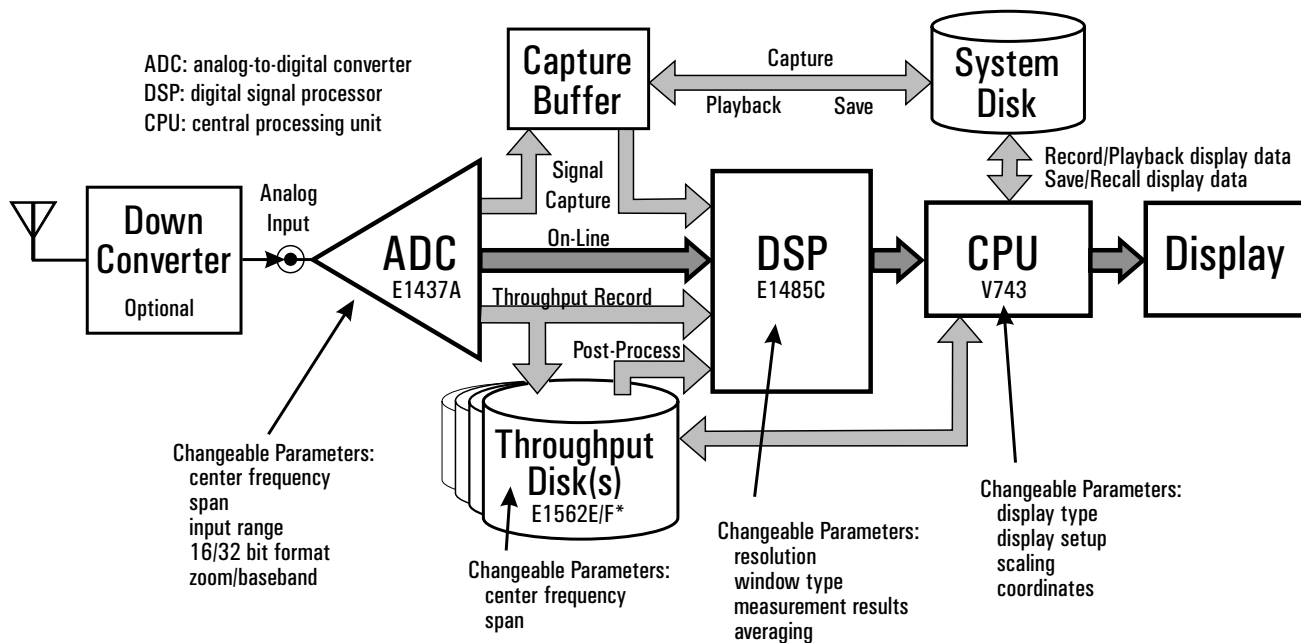

*Option ATR hardware.
SCSI disks connected
together with external
(front-panel) cables.

The *Changeable Parameters* in the figure are the analyzer's user-defined settings which determine how the data is measured, processed, stored, and displayed for the main blocks affecting the data. The point of collection determines what parameters can be changed during post-processing: the parameters between the collection point and the input *cannot* be changed; the parameters between the collection point and the CPU block *can* be changed.

Collection Methods

A discussion of each data collection method follows.

Signal Capture Data

Signal capture stores time data in a FIFO buffer on the ADC. The buffer can then be saved to the system disk. Signal capture data is gap-free; the data represents a continuous stream of ADC samples with no data loss between samples. The buffer size depends on the RAM installed on the ADC; as much as 64 MB may be installed.

The time represented by 64 MB of data depends on the measurement span and data width. Wide spans require high sample rates. A 4 MHz span takes 10.24 Msamples/s. If the data is 16-bit samples (2 bytes/sample), the maximum buffer capacity is 32 Msamples. With these settings, the buffer holds roughly 3.2 seconds of data. For 32-bit data, the buffer capacity is 16 Msamples.

Signal capture data is *unprocessed* measurement data. This allows analysis flexibility when it is post-processed. Signal capture data can be post-processed by changing parameters in the DSP and CPU blocks.

This collection method allows more versatility for post-processing data than saving or recording display data. When you play back a signal capture data file, you can select any measurement results (frequency, time, or amplitude) as well as the average type, resolution, or display type. Recalled display data allows changing only display parameters such as display type, scaling, and coordinates.

Throughput Capture Data (option ATR)

Throughput capture uses a VXI-SCSI disk interface module (E1562E, which contains two disk drives and two SCSI bus controllers) to capture ADC data (see previous figure). Throughput capture data is gap-free; the data represents a continuous stream of ADC samples with no data loss between samples. The monitor data displayed during throughput recording may have gaps, however.

This collection method has more post-processing versatility than either the signal capture or display data methods. Throughput capture data is *unprocessed* measurement data. When you post-process a throughput capture data file, you can change all the parameters described in the signal capture method as well as re-zoom and filter the original data for more refined band-selectable frequency analysis. See "Post-Processing Capture Data" on page 88 for an example of wideband recording/narrowband post-processing.

The throughput disk system is expanded via the SCSI bus by adding E1562F modules; see previous figure. Besides increasing the storage capacity, each additional module increases the span at which data can be recorded. Each MHz of span requires a 5.12-MB/s writing rate for 16-bit data; 10.24-MB/s for 32-bit data. Each E1562E/F has a writing rate which supports 2 MHz of span (with 16-bit data). Two E1562 modules are required to record a 4 MHz span with 16-bit data width. The maximum data rate is limited by the disk controllers. See note 3 on next page.

All installed disks appear as one LIF file system with a capacity equal to the sum of the individual disk capacities. See note 2 on next page. A system with two E1562E/F modules has a capacity of 16 GB which can contain one file. With the span=4 MHz and data width=16 bits, this is about 13 minutes of continuous data.

Data Extraction

Portions of a throughput capture file can be copied to another (smaller) file as segments defined by start/stop time or sample indexes. (Assuming there is room on the throughput disk for the new file.) After creating the smaller file, it can be moved to the system disk with the throughput file utilities. See “Extracting Data From Capture Files” on page 90.

Data Reduction

Another way to reduce captured data is to post-process the throughput capture data at a smaller span and save or record it from the CPU block to the system disk. This creates display data files on the HP-UX system disk, not time-domain data files as does the data-extraction method. See “Post-Processing Capture Data” on page 88.

Notes

- 1)** Before the throughput disk system is used, it must be initialized (formatted). This was done at the factory and should only be done again if you change one of the E1562 disk modules. It can also be done to delete all files from the disks.
Caution: Initializing the disk deletes all files stored there.
 - 2)** Each E1562 module has two disk drives. The drives in the E1562B/C modules have a capacity of 2 GB each. The drives in the E1562E/F modules have a capacity of 4 GB each. You may use E1562E/F drives in the same system with E1562B/C drives, but only half of the E/F drive capacity is utilized. This is due to the data-stripping write method used by the SCSI controllers in the B and E modules.
 - 3)** The maximum data rate that the disk controllers support is 20 MB/s. The data rate is determined by span and data width. With a span of 4 MHz (10 MSa/s) you can collect 16-bit samples but not 32-bit samples. The throughput capture system does not support the full 8 MHz span of the E1437A ADC. The system does not stop you from selecting values that exceed the data rate limit, but the disk controllers cannot pass data as fast as the ADC fills its FIFO buffer. When the FIFO becomes full, the ADC stops putting data in it. The disk controllers will continue to take data from the FIFO and write to disk until the FIFO is empty.
 - 4)** The disk drives in the E1562B/C modules self-calibrate periodically, based on the time since power-on or the last calibration. After being on 2 hours and 40 minutes, calibration occurs approximately every hour, depending on disk activity. Each disk has a buffer which continues to accept data during a calibration, but data cannot be written to a disk while it is calibrating. A calibration cycle could terminate a throughput capture if the data rate is so high that the disk buffers fill before the calibration ends. The data rate is determined by the measurement span and input data width (16 or 32-bit data). **To minimize the chance of disk calibration prematurely terminating a recording, perform a manual calibration just before starting the throughput capture.** The E/F drives do not require this consideration.
-

Display Data

Display data is processed measurement data collected from the CPU block. It is collected with either Save Data or Record Data to the system disk. The difference between saving and recording display data is that Save Data writes the current data in the display buffer to the system disk (i.e., data collected earlier) and Record Data writes the display data to the system disk starting when you initiate it and continues until you stop it (i.e., data collected in the future). Since display data is processed measurement results, only CPU-block display parameters can be changed when you recall or playback display data.

[SAVE DATA] writes all processed measurement data in the display memory to the system disk. The maximum length of the saved file is limited to the specified display [BUFFER DEPTH] (set in the [DISPLAY SETUP], [MEMORY CONFIGURATION] menu). Use [SAVE DATA] for map displays to store a unique number of traces to a file. Traces in the display buffer (up to the [FILE LENGTH]) are saved.

[RECALL] reads an entire data file from the system disk into the display memory and displays it statically; i.e. it does not look like a measurement is running. When you recall map data and the display memory buffer size is less than the file size, a truncated version of the file appears. To recall and display the entire file, either increase the [BUFFER DEPTH] or use the [PLAYBACK] feature instead to recall the data. See "Recording and Playing Back Display Data" on page 94 for an example.

[RECORD] writes each data record to disk as the data is taken and processed. Recording runs until the disk is filled when you select [FOREVER] as the [FILE LENGTH]. For map displays, [RECORD] saves the number of traces specified in the [FILE LENGTH] and starts storing when the record process starts, whereas [SAVE DATA] stores traces already in the display buffer. See "Recording and Playing Back Display Data" on page 94.

[PLAYBACK] displays data records dynamically; i.e., it looks like an on-line measurement is running. It is useful for analyzing a file that is too large to fit in display memory. [PLAYBACK] repeats the played back file indefinitely.

Notes

Data collected with either [SAVE DATA] or [RECORD] can be recalled or played back. To maximize the display buffer depth decrease the number of measurement results that are turned on and/or decrease the block size of each data record. See "Checking System Disk Space" on page 99 for more on memory constraints. Collecting display data does not have the 8 MByte record size limitation associated with signal capture. Therefore, much more data can be stored in each file, as determined by the file length parameter.

File Systems & Data Formats

The throughput disk SCSI controllers use the LIF file system which is significantly different from the HP-UX file system. Here are some important points:

- The throughput disk file system (LIF) is flat; all files exist in one directory.
- The system disk file system (HP-UX) is hierarchal.
- Files may be copied between the two file systems with file utilities provided.
- The HP-UX kernel parameter MAXFILESIZE limits the largest file size (typically 2 GB for HP-UX 9.0 and 20 GB for HP-UX 10)
- Throughput files are archived from the E1562 with the hp3587sar utility.
- The throughput file data format is SDF (standard data format); see next note.
- The signal capture file data format is SC (see option AGG documentation).
- File formats may be converted with the SCtoSDF and SDFtoSC utilities.

Note

The format of the throughput disk capture files is Standard Data Format (SDF). An SDF file consists of several headers followed by measurement data in binary form. The headers contain information such as measurement settings to help reconstruct the data. SDF files may be converted to other formats with the SDF Utilities which are included with option ATR. See Appendix B of the *Standard Data Format Utilities User's Guide* for a description of the SDF structure.

Signal Capture

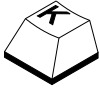

1. Connect a 500 kHz 0.5 Vrms sine wave to the HP E1437A input module.
2. Press
[HOME]
[PRESET]
[ALL]
[HOME]
[TRIGGER]
[TRIG MODE]
[LEVEL]
[RETURN]
[TRIG LEVEL]
Type 80 and press [Enter/Return] on the keyboard
[ARM MANUAL]
[RETURN]

3. Press
[HOME]
[MEASUREMENT]
[SIGNAL CAPTURE]
[CAPTURE SIZE]
[131072 SAMPLES]
[RETURN]
[CAPTURE MODE]
[ON]

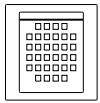

4. If the measurement is not running, press
[RUN]

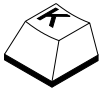

5. Press
[ARM]

6. Increase the function generator output level until new data appears on the display.
This indicates that the data has been captured to the signal capture buffer.

7. To save the captured data currently in the signal capture buffer, press
[HARD DISK UTILITIES]
[FILE TYPE]
[CAPTURE]
[WRITE PRCT OFF]
[RETURN]
[SAVE CAPTURE]
Type CAPTURE1 and press [Enter/Return] on the keyboard.
[RETURN]

Analysis

The second step sets up a manual arm for triggering the signal capture. In this case a signal capture occurs whenever the signal level is 80% of the full scale input range. The last step stores the captured data in "CAPTURE1".

To capture multiple sets of data to sequentially-numbered file names, use [AUTO RECORD]. If you use a manual arm, you must re-arm the trigger between captures just as in the previous example. See "Recording and Playing Back Display Data" (page 94) for an example of using [AUTO RECORD].

Background

Signal capture lets you collect gap-free data. The maximum capture size depends on the amount of RAM installed on the ADC and DSP modules as well as the [DATA WIDTH] setting (in the [INPUT SETUP] menu). Some relatively small amount of RAM on the DSP is used for internal processing. With 64 MB of RAM on both the ADC and DSP there will be approximately 60 MB of memory available for data capture. With 32 MB on the ADC and 64 MB on the DSP, you will have 32 MB available. (ADC RAM is also referred to as the FIFO buffer.)

The maximum capacity available is the largest value in the [CAPTURE SIZE] list. The values in this list are *samples* in powers of 2 except for the largest, which is calculated based on installed RAM minus (if DSP RAM > ADC RAM) DSP RAM in use. The number of *samples* this RAM value (*n*) represents depends on the data width. If the [DATA WIDTH] is 16-bit, the maximum capture size is $n / 2$ samples. If the [DATA WIDTH] is 32-bit, the maximum capture size is $n / 4$ samples.

In addition to capturing large amounts of gap-free data, saving signal capture data offers more versatility for post-processing than saving or recording CPU data. You can change the resolution, averaging, window type, measurement results, and zoom parameters when you play back captured data. These parameters cannot be changed when it is collected using [SAVE DATA] or [RECORD] in the [RECORD/PLAYBACK] menu. See the introduction of this chapter for more information about how signal capture works and how it compares with other methods of data collection.

Note

To perform playback analysis, a saved signal capture file must be read entirely into DSP RAM. The system used to play back a captured data file must have a capture size capacity at least as large as that used to capture it.

Playing Back Captured Data

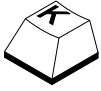

1. Complete the steps in "Signal Capture" on page 84.
2. Press
[HOME]
[MEASUREMENT]
[SIGNAL CAPTURE]
[FILENAME]
Type CAPTURE1 and press [Enter/Return] on the keyboard
[CAPTURE MODE]
[PLAYBACK]

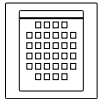

3. Press
[Run] and notice the capture data on the display.

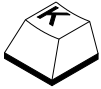

4. Change this to a time display by pressing
[RETURN]
[MEASUREMENT RESULTS]
Toggle to [TIME ON]
[HOME]
[DISPLAY]
[DSPLY TYPE]
[NEXT]
[TIME]

The data is played back one data record at a time, and repeats playing back the same file indefinitely.

In addition to changing coordinates, scaling or any other display parameter, you can also change the resolution, averaging, window type, and measurement results on played back signal capture data.

Note

To perform playback analysis, a saved signal capture file must be read entirely into DSP RAM. The system used play back a captured data file must have a capture size capacity at least as large as that used to capture it. See background discussion under the signal capture exercise.

Throughput Capture (option ATR)

Throughput capture is provided with option ATR. To determine if option ATR is installed, press [HOME], [SYSTEM], [DIAGNOSTICS], [OPTIONS INSTALLED].

Also, before performing this task, please read the introduction to this chapter.

To capture a data file on the E1562 Throughput Disk, perform the following steps:

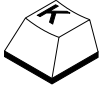

1. Change the span to 500 kHz. Press:
[HOME]
[MEASUREMENT]
[FREQUENCY SETUP]
[SPAN FREQ]
[500.0000 kHz]
[RETURN]
[RETURN]
2. Setup the throughput capture and start it. Press:
[SIGNAL CAPTURE]
[THRUPT DISK CAPTURE]
[FILENAME]
Enter a filename like THRU and press [RETURN]
[THRUPT MODE]
[RECORD]
[RETURN]

Data is now being recorded on the throughput disk. A portion of the data being recorded is also displayed (see the figure in the introduction). The path that branches from the throughput disk and goes to the DSP block provides the path for the data used to monitor the data being recorded. In some cases, the display processing cannot keep up with the data rate. When the data is post-processed there are no gaps in the displayed data.
3. When the status message appears that indicates that the capture is complete, press:
[THRUPT MODE]
[OFF]
[RETURN]
4. To display information about the captured data file, perform the following steps.
[HOME]
[MEASUREMENT]
[SIGNAL CAPTURE]
[THRUPT DISK CAPTURE]
[THRUPT FILE UTILITIES]
[DISPLAY FILE INFORMATION]

See the discussions on post-processing and extracting throughput data.

Post-Processing Capture Data (option ATR)

This capability is provided with option ATR. If your system does not have this option installed, this task cannot be performed. To determine if option ATR is installed, press [HOME], [SYSTEM], [DIAGNOSTICS], [OPTIONS INSTALLED].

Measurement data captured on the throughput disk can be post-processed in much the same manner as on-line data is analyzed. The only difference is that you cannot change the input parameters of the data. Because the data passes through the DSP block, it can be refiltered and zoomed. See the diagram in the introduction of this chapter.

To post-process a data file on the E1562 Throughput Disk, perform the following steps:

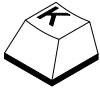

1. Select the file to post-process. Press:
[HOME]
[MEASUREMENT]
[SIGNAL CAPTURE]
[THRUPT DISK CAPTURE]
[FILENAME]
Enter the name of the file you wish to analyze and press [RETURN]
[THRUPT MODE]
[POST-PROCESS]
[RETURN]
2. To start or restart the post-processing measurement, press:
[RUN]
3. To stop post-processing and go back to on-line measurements, press
[THRUPT MODE OFF]

The following illustrations demonstrate using option ATR to perform wideband recording followed by narrowband post-processing. In this example, an HP 3587S with option ATR is configured with an optional HP 89431A RF downconverter. The first illustration shows the frequency spectrum recorded; a 2 MHz portion of the FM radio broadcast band, centered at 98.625 MHz, with multiple carriers present.

Option ATR (with four E1562 disk modules) recorded all the information in this band for 13 minutes. After the recording was complete, the post-processing capabilities of option ATR were used to isolate a single carrier via digital re-zooming and filtering (i.e. band-selectable analysis).

The second illustration shows the resulting spectrum and time data of the isolated carrier; a 250 kHz portion of the FM radio broadcast band, centered at approximately 98.1 MHz. This carrier is the largest amplitude carrier in the original spectrum shown in the first display. Option ATR's flexible post-processing capabilities can easily be employed to re-zoom and isolate any carrier or signal in the recorded band.

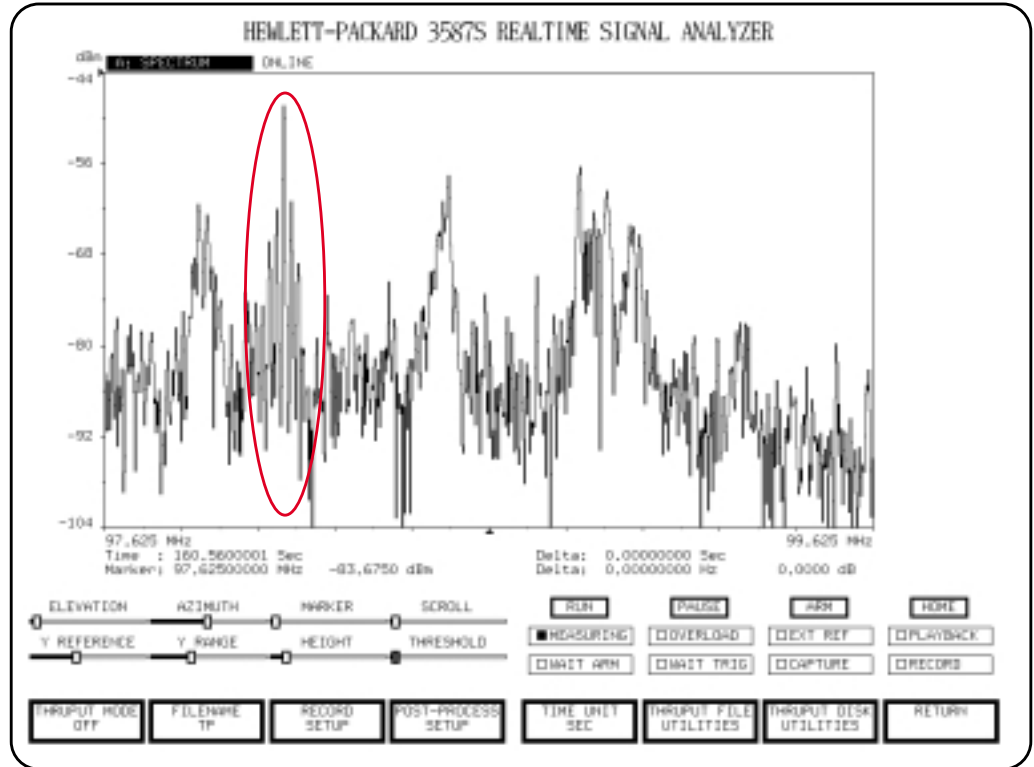

Wideband recording of a 2 MHz portion of the FM radio broadcast band. Center scale is 98.625 MHz.

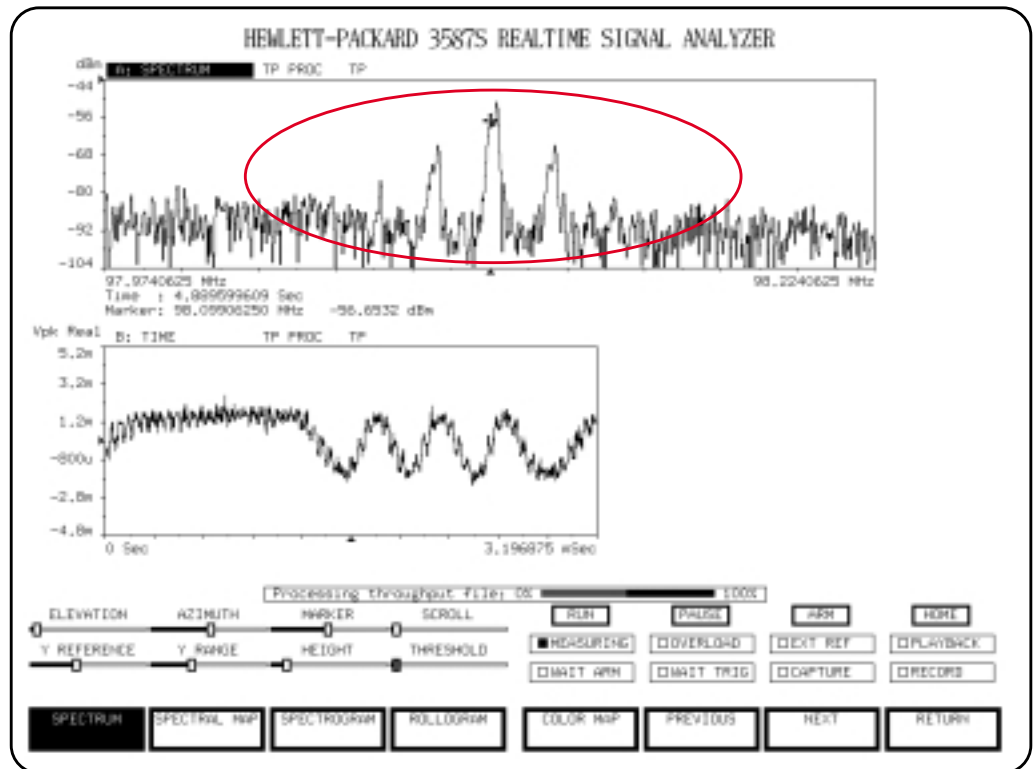

Post-processing the throughput capture data; this is a 250 kHz portion centered on 98.1 MHz.

Extracting Data From Capture Files (option ATR)

This capability is provided with option ATR. If your system does not have this option installed, this task cannot be performed. To determine if option ATR is installed, check [HOME], [SYSTEM], [DIAGNOSTICS], [OPTIONS INSTALLED].

Throughput capture files can be very large. You can extract portions of a file to create smaller files for post-processing or for data archiving. This is demonstrated in the following:

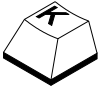

1. Select the file to extract data from. Press:
[HOME]
[MEASUREMENT]
[SIGNAL CAPTURE]
[THRUPTUT DISK CAPTURE]
[THRUPTUT FILE UTILITIES]
[EXTRACT FROM THRUPTUT FILE]
[COPY FROM]
Enter the filename and press [RETURN]
2. Select the file to put the extracted data in. Press:
[COPY TO]
Enter the filename and press [RETURN]
3. Select the location and amount of data to extract from the [COPY FROM] file. Press:
[COPY BEGIN]
Enter the beginning location of the data to extract and press [RETURN].
The COPY BEGIN and COPY END values can be specified in units of seconds, minutes, or samples. The unit is selected in the [HOME], [MEASUREMENT], [SIGNAL CAPTURE], [THRUPTUT DISK CAPTURE], [TIME UNIT] menu.
4. Create the new file containing the extracted data. Press:
[PERFORM COPY]

The new file can now be post-processed or archived.

Archiving and Restoring Capture Files

The `hp3587sar` utility is a command-line executable program used with the `tar` command to archive and recall throughput capture files on the E1562 LIF disk.

Note

This utility cannot be used when the `hp3587s` program is running.

hp3587sar Archive Utility Switches

The command line switches for the `hp3587s` archive utility are as follows:

Switch Parameters	Description	Default Setting
-u	Display this text	
-N <lif_vol_name>	E1562 LIF volume name	[default]
-I	Initialize e1562 LIF disk	
-L	List e1562 directory w/ file sizes	
-l	List e1562 directory	
-c <file-list>	Create an archive, listed LIF files	
-C	Create an archive, all LIF files	
-x <file-list>	Extract from an archive	
-X	Extract all files from an archive	
-A <archive-device>	Archive device or file	[/dev/rmt/0m]
-t	List the archive contents	
-d	Display program description	
-v	Display messages when running	
-S <directory>	System Directory	[/opt/hp3587s/]
-W <directory>	Working Directory	[./]
-a <address>	Logical Address of E1485A	[128]
-Z <interface>	VXI Interface Name	[vxi]
-T <address>	Logical Address of E1562B	[144]

The following CONFIGURATION file entries can be used instead of the command line switches:

```
VXI Interface      : interface
Archive Device    : archive-device
E1562b Logical Address : address
E1485a Logical Address : address
E1562b Lif Volume  : lif_vol_name
System Directory  : directory
Working Directory  : directory
```

Examples

To list the files on the E1562 LIF disk:

```
hp3587sar -L
```

To archive all files on the E1562 LIF disk to DDS tape:

```
hp3587sar -C
```

To restore all files on a DDS tape to the E1562 LIF disk:

```
hp3587sar -X
```

To list the contents of a DDS tape archive:

```
hp3587sar -t
```

or

```
tar t
```

To restore one file on a DDS tape to the E1562 LIF disk:

```
hp3587sar -x <filename>
```

To archive one file on the E1562 LIF disk to DDS tape:

```
hp3587sar -c <filename>
```

To transfer a list of files from the HP-UX system disk to the E1562 LIF disk:

```
tar cf archive.tar <list of HP-UX filenames>  
hp3587sar -X
```

To transfer a list of files from the E1562 LIF disk to the HP-UX system disk:

```
hp3587sar -Aarchive.tar -C  
tar xf archive.tar
```

Notes

The file system directory structure of HP-UX 10.20 is significantly different from that of HP-UX 9.0x. See the software installation note for more detail.

When files are restored (-x or -X), the date and time of creation are set to the current time of day, not the date and time the file was created.

When a file is archived, the file's *logical* length is archived, not the *physical* length. When the file is restored, its physical length is the file's logical length (rounded up to the nearest LIF sector size), not the original physical size.

When an archive requires more than one tape, the user must keep track of the tape order. No information about loading order is stored on the tape(s).

The archived file's permissions setting is 0644, group and user id's are set to those of the running process, and the modification time is set to the current time.

The hp3587sar program archives and restores files between the E1562 LIF disk and the archive device. It cannot archive or restore HP-UX files.

Saving and Recalling Display Data

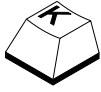

1. Save display data by pressing
[HOME]
[MEASUREMENT]
[RECORD/PLAYBACK]
[HARD DISK UTILITIES]
[WRITE PRCT OFF] (to allow data storage to disk)
[RETURN]
[SAVE DATA]
Type a filename such as DATA1 and press [Enter/Return] on the keyboard.

2. Recall data by pressing
[HOME]
[MEASUREMENT]
[RECORD/PLAYBACK]
[FILENAME]
Select the desired file and press [Enter/Return] on the keyboard.
(To scroll through the user file names, use the up or down arrow keys.)
[MODE]
[RECALL] and the stored data is recalled to the display.

Recording and Playing Back Display Data

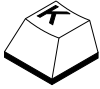

1. Complete the steps in “Online Measurements” on page 58.

2. Press

[HOME]

[MEASUREMENT]

[RECORD/PLAYBACK]

[FILENAME]

Type TEST and press [Enter/Return] on the keyboard

[FILE LENGTH]

Type 50 and press [Enter/Return] on the keyboard

[SYSTEM DISK UTILITIES]

[RECORD BASE]

[1] (this is the default)

Toggle to [AUTO RECORD ON]

[RETURN]

[MODE]

[RECORD]

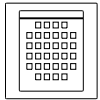

3. If the measurement is not running, press

[RUN]

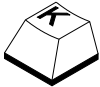

4. Wait for the RECORD indicator to turn off. Repeat the record process as many times as you like by pressing [MODE] [RECORD], assuming the measurement is running. If it is paused, press [RUN] or [CONT] first. Each time you record, the data is stored in sequentially-numbered files.

5. To play back the data, press

[MEASUREMENT]

[RECORD/PLAYBACK]

[FILENAME]

Type TEST1 and press [Enter/Return] on the keyboard

[MODE]

[PLAYBACK]

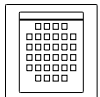

6. Press

[RUN] and notice the same data playing back one trace at a time.

In this example, the first 50 traces are recorded to the first file (in this case test1) and each subsequent set of 50 traces are recorded to sequential files (test2, test3, etc.). Playback of TEST1 recalls the first 50 traces, one at a time, and repeats playing back the same file indefinitely. Note that you can change coordinates, scaling, or any display parameter on the played back data.

Displayed data can be recalled or played back regardless of whether the data was stored using [SAVE DATA] or [RECORD]. See “Saving and Recalling Trace Data” on page 93 to compare record/playback with save/recall operations.

Saving a Single Trace



1. If you want to save a single trace from a stored map file, play back or recall the file by completing the last two steps in “To record and playback trace data” or the last step in “To save and recall trace data”.
2. Press
[Pause/Cont]
when the trace you want to save is displayed.
3. Click on that trace so that it changes color. Use the [SCROLL] knob on the knob box to scroll from one trace to another.
4. Press
[HOME]
[MEASUREMENT]
[RECORD/PLAYBACK]
[FILE LENGTH]
[1 TRACE]
[SAVE DATA]
Type a file name and press [Enter/Return] on the keyboard.

You can also use this method to save several consecutive traces from a file which may have more data than you need. Simply click on the first trace of interest and select the appropriate [FILE LENGTH] so that all the traces of interest are included. Once you have stored all traces of interest, you can delete the larger file and significantly increase the amount of available disk space.

Displaying State Information

There are four categories of state information:

Input state
Measurement state
Data header
Trace state



1. Display the current input parameters by pressing
[HOME]
[STATE]
[INPUT STATE]
2. Display the current measurement (instrument) state by pressing
[HOME]
[STATE]
[MEASUREMENT STATE]
3. Display the instrument state used for taking the data in the active trace by pressing
[HOME]
[STATE]
[DATA HEADER STATE]
4. List the display state of the currently active trace by pressing
[HOME]
[STATE]
[TRACE STATE]

It is important to be aware of which instrument parameters can be changed for the currently displayed data. There are four types of state information.

[INPUT STATE] lists the current instrument parameters which can be changed during online measurements only.

[MEASUREMENT STATE] lists the current instrument settings which can be changed during online measurements and during playback of signal capture data.

[DATA HEADER STATE] lists the same parameters as [MEASUREMENT STATE]. The only difference is [DATA HEADER STATE] lists the settings for the active trace which may be different because the data can be playback or recalled data.

[TRACE STATE] lists the display parameters, coordinates and scaling for the currently active trace. These parameters may be changed for any type of displayed data.

The following figure illustrates the different types of states.

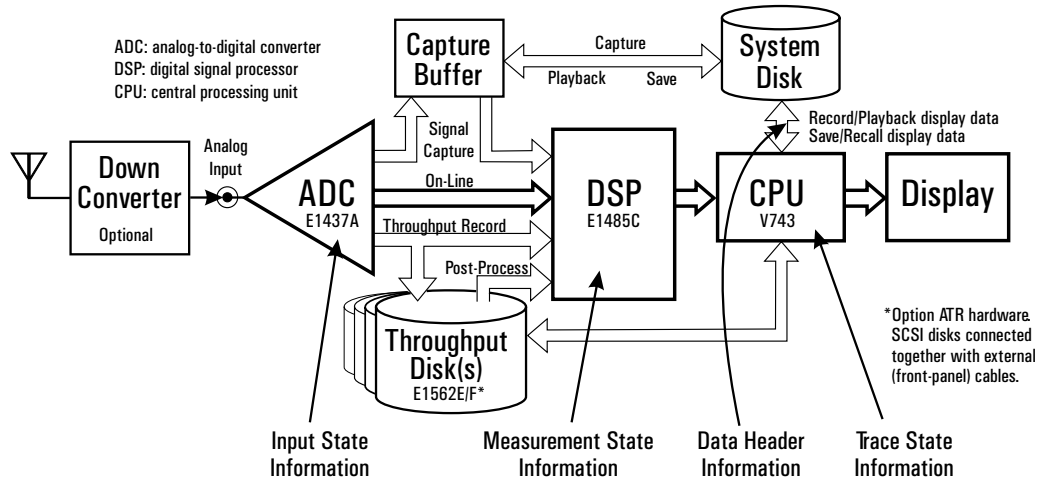

If multiple traces are active, [DATA HEADER STATE] and [TRACE STATE] show the state of the *first* active trace. To display the [DATA HEADER STATE] or [TRACE STATE] of another trace, you must make that trace active.

The following shows an example of a measurement state listing. See “Printing” on page 52 to learn how to get a hardcopy listing of the instrument state.

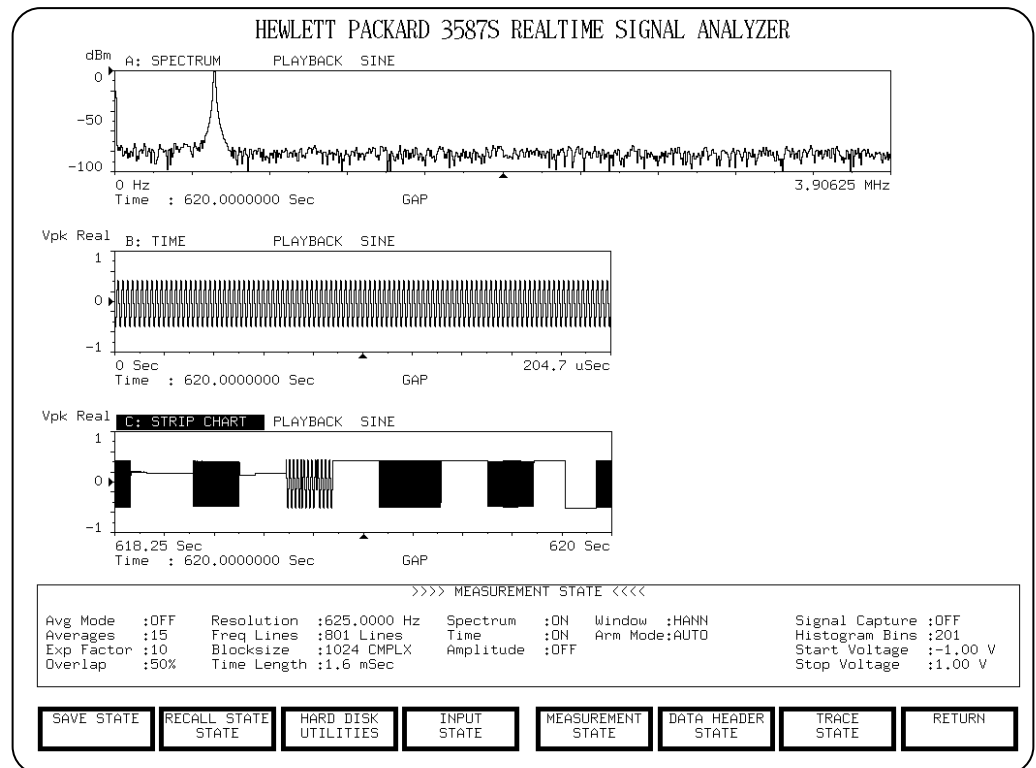

The measurement state information appears below the trace display.

Saving and Recalling Instrument State

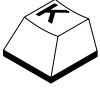

1. Press
[HOME]
[STATE]
[SAVE STATE]
Type a file name and press [Enter/Return] on the keyboard. Notice the status message below the display confirming that the state has been saved.
2. Recall an instrument state by pressing
[HOME]
[STATE]
[RECALL STATE]
Select the desired file and press [Enter/Return] on the keyboard.

To scroll through the available instrument state file names, use the up or down arrow keys.

Checking System Disk Space

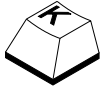

1. Press
[HOME]
[MEASUREMENT]
[RECORD/PLAYBACK] or [SIGNAL CAPTURE]
[HARD DISK UTILITIES]
[FILE SYSTEM INFORMATION]

The amount of available disk space and total disk space are displayed.

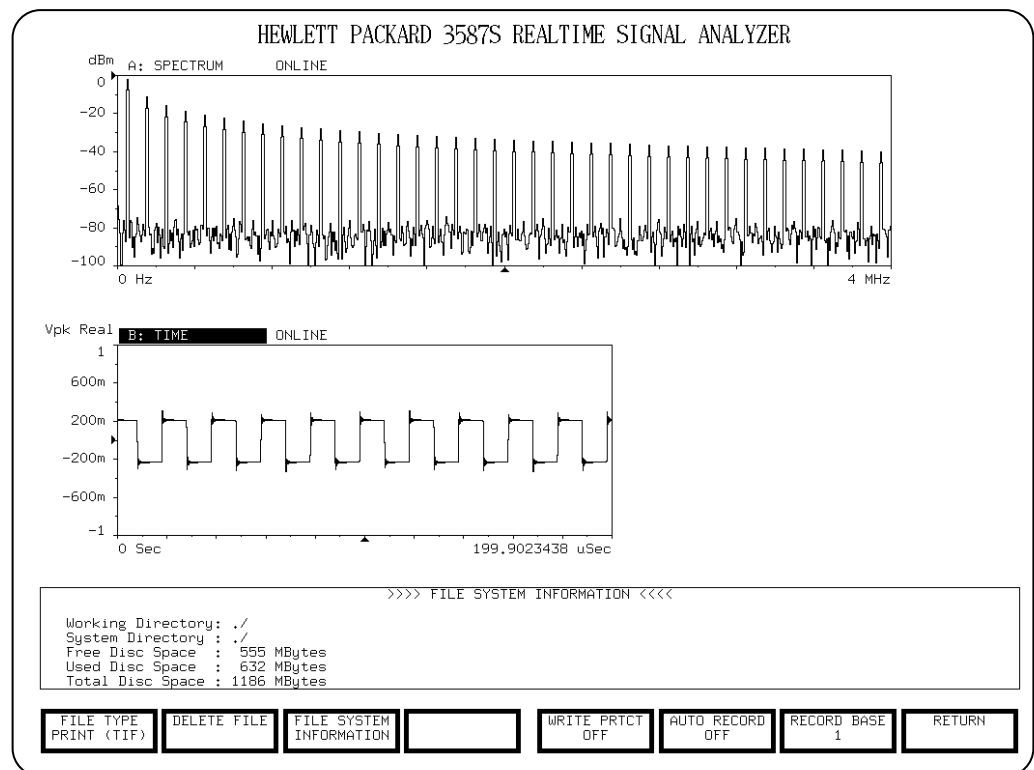

Disk space information appears below the trace display.

Memory Usage

The amount of memory used depends on several parameters as shown below. Performance is affected by the CPU loading caused by other processes. The limit is set by changing the `Max Data Size` parameter found in the `CONFIGURATION` file. When this value is zero, the program uses the maximum allowed by the system.

When the system runs low on RAM, it uses virtual memory (swapping to disk) which usually reduces performance significantly. A general guideline to use is that total memory required is no more than 60% of the host's installed RAM. The following equations describe memory usage in more detail.

```
TotalMemory = ScaleBufferMemory + DataMemory
if (scaleBuffer = ON)
    ScaleBufferMemory = (((DispWindowSize / 4) + 4) * NumTraces) * BufferDepth;
if (scaleBuffer = OFF)
    ScaleBufferMemory = (((DispWindowSize) / 4) + 4) * NumTraces;
DataMemory = DataHeader + (Status + Blocksize) * BufferDepth
```

where:

Display Window Size depends on the display screen resolution as:

screen resolution	Display Window Size
640 480	512 points
1024 768	801 points
1280 1024	1024 points

Status (time stamp plus status such as overload and gap) = 12

Blocksize depends on how many [MEASUREMENT RESULTS] are turned on. To get the Blocksize value in the equation above, add the following values for each measurement result that is turned on:

```
If [ SPECTRUM ] is on, ([ #LINES ] + 1) * 4
If [ HISTOGRAM ] is on, ([ HISTOGRAM BLOCKSIZE ] + 2) * 4
If [ TIME ] is on and [ REAL ] coordinates are used, [ TIME
LENGTH (REAL) ] * 4
If [ TIME ] is on and [ IMAGINARY ] coordinates are used, [ TIME
LENGTH (IMAG) ] * 4
```

Example

Given the following settings, Total Memory is calculated as

Spectrum: on
Histogram: off
Time: off
Lines : 801
Time Length (# data points): 2048 real
Buffer Depth : 100
Display Window Size: 1024 768 (801 points)

$$\begin{aligned} \text{Data Memory} &= 520 + [12 + [801 + 1] \cdot 4] \cdot 100 \\ &= 322,520 \text{ bytes} \end{aligned}$$

if(scaleBuffer is ON)

$$\begin{aligned} \text{Scale Buffer Memory} &= [[[1024 \cdot 4] + 4] \cdot 100] \cdot 3 \\ &= 1,230,000 \text{ bytes} \end{aligned}$$

$$\begin{aligned} \text{Total Memory} &= 1,230,000 + 322,520 \\ &= 1,552,520 \text{ bytes} \end{aligned}$$

if(scaleBuffer is OFF)

$$\begin{aligned} \text{Scale Buffer Memory} &= [[1024 \cdot 4] + 4] \cdot 3 \\ &= 12,300 \text{ bytes} \end{aligned}$$

$$\begin{aligned} \text{Total Memory} &= 12,300 + 322,520 \\ &= 334,820 \text{ bytes} \end{aligned}$$

Copying Saved Display Data



1. Press
[HOME]
[MEASUREMENT]
[RECORD/PLAYBACK]
[FILENAME]
Type the name of the file you want to copy and press [Enter/Return] on the keyboard.
[MODE]
[RECALL]
[FILE LENGTH]
Type 0 and press [Return] on the keyboard.
[SAVE DATA]
Type the name of the file to which you want to copy and press [Enter/Return] on the keyboard.

Specifying a [FILE LENGTH] of 0 means the entire recalled file will be saved to the new file (i.e. "forever").

Copying Saved Signal Capture Data

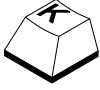

1. Press
[HOME]
[MEASUREMENT]
[SIGNAL CAPTURE]
[FILENAME]
Type the name of the file you want to copy and press [Enter/Return] on the keyboard.
[CAPTURE MODE]
[PLAYBACK]
[RETURN]
[SAVE CAPTURE]
Type the name of the file to which you want to copy and press [Enter/Return] on the keyboard.

Deleting a File

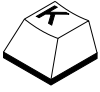

1. [MEASUREMENT]
[RECORD/PLAYBACK] or [SIGNAL CAPTURE]
[SYSTEM DISK UTILITIES]
[FILE TYPE]
2. Press
[DATA] to select from the list of processed data files,
[CAPTURE] to select from the list of an unprocessed data files or
[STATE] to select from the list of instrument state files.
3. Press
[DELETE FILE]
Use the up or down arrows to select the file you want to delete and press [Enter/Return]
on the keyboard.

Appendix A: Keyboard User's Guide

Use the following guides to perform equivalent knob or button box operations using the keyboard.

Note that only the default functions for the knob and button boxes are given. If you have the HP 35687B Option AGG and you have customized the default KNOBSYSTEM or BUTTONSYSTEM files, the menu maps may not apply.

Button Box Functions

The button box provides quick access to functions within the softkey command tree. The default functions for the button box are defined as follows:

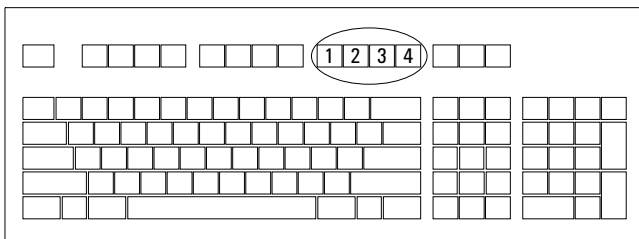
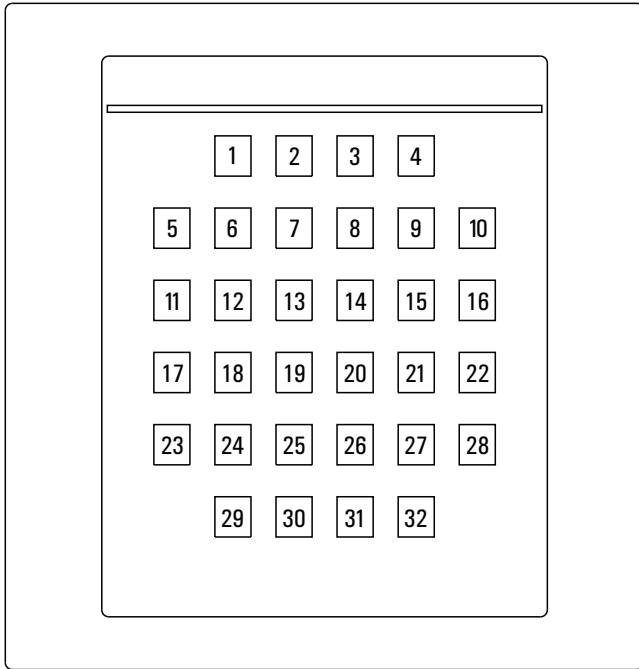

1. [Run]
2. [Pause/Cont]
3. [Arm]
4. [Home]

5. [DISPLAY] [DIPLY TYPE] [SPECTRUM]
6. [DISPLAY] [DSPLY TYPE] [SPECTRAL MAP]
7. [DISPLAY] [DSPLY TYPE] [SPECTROGRAM]
8. [DISPLAY] [DSPLY TYPE] [ROLLOGRAM]
9. [DISPLAY] [DSPLY TYPE] [COLOR MAP]
10. [DISPLAY] [DSPLY TYPE] [TIME]
11. [MARKERS] [MARKER MODE] [OFF]
12. [DISPLAY] [DSPLY FORMAT] [SINGLE]
13. [DISPLAY] [DSPLY FORMAT] [DUAL]
14. [DISPLAY] [DSPLY FORMAT] [TRIPLE]
15. [DISPLAY] [DSPLY FORMAT] [OVERLAY]
16. [MARKERS] [MARKER FUNCTIONS] [MARKER TO PEAK]
17. [MARKERS] [MARKER MODE] [SINGLE]
18. [DISPLAY] [ACTIVE TRACE] [A]
19. [DISPLAY] [ACTIVE TRACE] [B]
20. [DISPLAY] [ACTIVE TRACE] [C]
21. [DISPLAY] [ACTIVE TRACE] [ABC]
22. [MARKERS] [MARKER FUNCTIONS] [NEXT PEAK RIGHT]
23. [MARKERS] [MARKER MODE] [RELATIVE]
24. [DISPLAY] [DSPLY SETUP] [PRESENTATION] [HIDDEN LINE]
25. [DISPLAY] [DSPLY SETUP] [PRESENTATION] [WIRE FRAME]
26. [DISPLAY] [DSPLY SETUP] [PRESENTATION] [GRID]
27. [DISPLAY] [DSPLY SETUP] [ROTATION] [SCROLL DIR]
28. [MARKERS] [MARKER FUNCTIONS] [NEXT PEAK LEFT]
29. [SYSTEM] [CUSTOMIZE] [KNOB BOX] [X/Y DISPLAY]
30. [SYSTEM] [CUSTOMIZE] [KNOB BOX] [MONITOR]
31. [SYSTEM] [CUSTOMIZE] [KNOB BOX] [COLOR]
32. [SYSTEM] [CUSTOMIZE] [KNOB BOX] [3-D DISPLAY]

Note Button functions may be redefined with the programming option AGG.

Knob Box Functions

All knob box functions appear as slide bars below the trace display. Select a function set with buttons 29 (red), 30 (blue), or 31 (green) on the button box. Activate a slide bar by clicking on it and dragging the mouse to the desired position or value. Function sets are as follows:

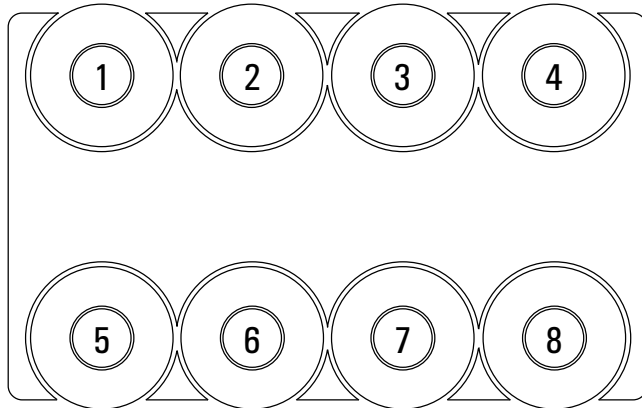

X/Y DISPLAY Knob Selections (red)

1. [DISPLAY] [DSPLY SETUP] [ROTATION] [ELEVATION]
2. [DISPLAY] [DSPLY SETUP] [ROTATION] [AZIMUTH]
3. [MARKERS] [MARKER VALUE]
4. [SCROLL]
5. [DISPLAY] [SCALE] [Y REFERENCE]
6. [DISPLAY] [SCALE] [Y RANGE]
7. [DISPLAY] [DSPLY SETUP] [ROTATION] [HEIGHT]
8. [DISPLAY] [DSPLY SETUP] [PRESENTATION] [THRESHOLD]

Note Knob functions may be redefined with the programming option AGG.

MONITOR Knob Selections (blue)

1. [MEASUREMENT] [FREQUENCY SETUP] [SPAN FREQ]
2. [MEASUREMENT] [FREQUENCY SETUP] [CENTER FREQ]
3. [MEASUREMENT] [RESOLUTION SETUP] [RESOLUTION]
4. [INPUT SETUP] [INPUT RANGE]
5. [DISPLAY] [SCALE] [Y REFERENCE]
6. [DISPLAY] [SCALE] [Y RANGE]
7. [DISPLAY] [SCALE] [X REFERENCE]
8. [DISPLAY] [SCALE] [X MAGNIFY]

COLOR Knob Selections (green)

1. [DISPLAY] [DSPLY SETUP] [3-D MAP COLORS]
[COLOR MAP]
2. [DISPLAY] [DSPLY SETUP] [3-D MAP COLORS]
[# COLORS]
3. [DISPLAY] [DSPLY SETUP] [SYSTEM COLORS]
[TRACE COLOR]
4. [DISPLAY] [DSPLY SETUP] [2-D TRACE COLORS]
[GRID COLOR]
5. [DISPLAY] [DSPLY SETUP] [COLOR] [BACKGND CLR]
6. [DISPLAY] [DSPLY SETUP] [IMAGE ENHANCEMENT]
[LOG FACTOR]
7. [DISPLAY] [DSPLY SETUP] [IMAGE ENHANCEMENT]
[X BRK POINT]
8. [DISPLAY] [DSPLY SETUP] [IMAGE ENHANCEMENT]
[Y BRK POINT]

Keyboard Accelerator Keys

Keyboard accelerators are keys which immediately execute common tasks. The following lists the default keyboard accelerators. If you have the HP 35687B Option AGG Software, you can change the functionality of the existing keyboard accelerators or make up your own by referring to "Customizing the Keyboard" in the Option AGG Customization Guide.

Keyboard Accelerator ¹	Function	Softkeys Executed
m	displays the current measurement state	[STATE] [MEASUREMENT STATE]
d	displays the data header state of the active trace (this can differ from the current measurement state if the data is played back or recalled)	[STATE] [DATA HEADER STATE]
t	displays the parameters used to set up the display for the active trace	[STATE] [TRACE STATE]
i	displays the current input state	[STATE] [INPUT STATE]
s	swap markers (marker ref marker)	
P	prints the screen to the currently specified printer	[HARDCOPY] [PRINT SCREEN]
R	starts recording data	[MEASUREMENT] [RECORD/PLAYBACK] [MODE] [RECORD]
S	Synchronize the scaling parameters (ref, Y range, Y ref, X range) between active traces. The higher active trace is copied to the lower active trace.	
	scrolls the marker trace up one trace in the active traces	
	scrolls the trace down one trace	
	moves the marker in the active trace one bin to the right	
	moves the marker in the active trace one bin to the left	
[Shift]	as above, but only moves the relative marker	
[Home]	Enters the marker value into one of two functions; the [CENTER FREQUENCY] or the [X REFERENCE]. Note that the function must be active to make the entry. (The softkey turns pink when it is active.) This is equivalent to having a marker-to-center frequency function.	
[Page Down]	page down one screen of data (if available)	
[Page Up]	page up one screen of data (if available)	

¹ The keyboard accelerators are case sensitive.

Appendix B: Display and Measurement Cross-Reference

This appendix includes two reference tables that will help you understand the relationships between measurement and display parameters. The first table shows which measurement results must be turned on to obtain certain display types and parameters. The second table shows which measurement setups and parameters have effect on each kind of measurement result.

Display Type vs Changeable Display Parameters

Display Type	Time	PR Time	Time Map	Strip Chart	Spectrum	PR Spect	Spectrl Map	Color Map	Spectrogram	Rollogram	Histogram	PDF	CDF	Hist Map	Hist CMap
Measurement Result ¹	Time				Frequency						Amplitude				
Display Setup:															
System Colors															
Screen Color	X	X	X	X	X	X	X	X	X	X	X	X	X	X	X
2-D Trace Colors															
Mkr Color	X	X	X	X	X	X	X	X	X	X	X	X	X	X	X
Rel Mrkr Clr	X	X	X	X	X	X	X	X	X	X	X	X	X	X	X
Line Color	X		X	X	X		X				X	X	X	X	
Grid Color	X	X			X	X	X				X	X	X		
Backgnd Clr	X	X	X	X	X	X	X	X	X	X	X	X	X	X	X
Gap Color									X	X					
3-D Map Colors															
# Colors		X				X		X	X	X					X
Map Color		X				X		X	X	X					X
Map Mode		X				X		X	X	X					X
Log Factor		X				X		X	X	X					X
X Brk Point		X				X		X	X	X					X
Y Brk Point		X				X		X	X	X					X
Saturation		X				X		X	X	X					X
Luminance		X				X		X	X						X
Rotation															
ELEVATION			X				X	X	X					X	X
Azimuth			X				X	X						X	X
Height			X				X	X						X	X
Scroll Dir			X				X	X	X	X				X	X
SGRM Lines									X						
Presentation															
Grid	X	X			X	X	X				X	X	X		
Threshold	X	X	X	X	X	X	X	X	X	X	X	X	X	X	X
Hidden Line			X				X							X	
Wire Frame			X				X							X	
Strip Chart Records				X											
Trace Fill	X				X						X	X	X		
Memory Config															
Buffer Depth	X	X	X	X	X	X	X	X	X	X	X	X	X	X	X
Freq Width					X	X	X	X	X	X	X	X	X	X	X
Time Width	X	X	X	X											

¹ The Measurement Result must be turned on to enable the Display Type

Display Type	Time	PR Time	Time Map	Strip Chart	Spec-trum	PR Spect	Spectrl Map	Color Map	Spectro-gram	Rollo-gram	Histo-gram	PDF	CDF	Hist Map	Hist CMap
Measurement Result¹	Time				Frequency						Amplitude				
Display Format:															
Single	X	X	X	X	X	X	X	X	X	X	X	X	X	X	X
Dual	X	X	X	X	X	X	X	X	X	X	X	X	X	X	X
Triple	X	X	X	X	X	X	X	X	X	X	X	X	X	X	X
Overlay	X				X						X	X	X		
Coordinates:															
Y-Axis Coord															
Mag (dB)					X	X	X	X	X	X					
Mag (dBm)					X	X	X	X	X	X					
Mag (log)					X	X	X	X	X	X					
Mag (lin)					X	X	X	X	X	X					
Real	X	X	X	X											
Imag	X		X	X											
None		X									X	X	X	X	X
Units															
Peak or RMS					X	X	X	X	X	X					
V or V ²					X	X	X	X	X	X					
Scale:															
X Magnify Ref	X	X	X		X	X	X	X	X	X	X	X	X	X	X
X Magnify	X	X	X		X	X	X	X	X	X	X	X	X	X	X
X Default	X	X	X		X	X	X	X	X	X	X	X	X	X	X
Y Reference	X	X	X	X	X	X	X	X	X	X	X	X	X	X	X
Y Range	X	X	X	X	X	X	X	X	X	X	X	X	X	X	X
Y Auto	X	X	X	X	X	X	X	X	X	X	X	X	X	X	X
Markers:															
Marker Mode	X	X	X	X	X	X	X	X	X	X	X	X	X	X	X
Marker To Peak	X	X			X	X					X	X	X		
Next Peak Left	X	X			X	X					X	X	X		
Next Peak Right	X	X			X	X					X	X	X		
Power					X	X									
Noise					X	X									

¹The Measurement Result must be turned on to enable the Display Type

Setup Parameters Which Affect Measurement Results

Parameters which effect each measurement result	Measurement Result		
	Time	Spectrum	Amplitude
Input Setup:	X	X	X
Trigger:	X	X	X
Measurement:			
Frequency Setup			
Baseband Mode	X	X	X
Zoom Mode	X	X	
Resolution Setup	X	X	
Averaging Setup		X ¹	X ²
Measurement Parameters			
Freq Window		X ³	
Overlap	X	X	X
Hist Blksize			X
Hist Start V			X
Hist Stop V			X

¹ All average modes

² # Averages function sets the number of accumulations

³ All types available

Appendix C: Preset Parameters

This table lists the functions affected by Preset and their default values.

Type of Preset	Function	Default Value		
Color Setup	Display Setup			
	System Color, Screen Color	Slate Blue		
	2-D Trace Colors,	Active Trace	A	
		Marker Color	Yellow	
		Relative Marker Color	Yellow	
		Trace Color	80% Gray	
		Grid Color	50% Gray	
		Background Color	Black	
		Gap Color	Cyan	
		3-D Map Colors	# Colors	32
			Map Colors	Color 1
			Saturation	100%
	Luminance		100%	
	Image Enhancement	Rotate Color	0	
		Map Mode	Normal	
		Log Factor	0	
		X Break Point	0.25	
		Y Break Point	0.5	
	Display Setup	Active Trace	A	
		Display Type	Spectrum	
Display Setup				
Rotation				
Active Trace		A		
ELEVATION		5 pixels		
Azimuth		0 pixels		
Height		50 pixels		
Scroll Direction		Up		
SPGM Lines		2		
Presentation				
Active Trace		A		
Grid		Off		
Threshold		0%		
Hidden Line		Off		
Wire Frame		Off		
Trace Fill		Off		
Strip Chart		128 records		
Memory Configuration				
Buffer Depth		100		
Frequency Width		801 pixels		
Time Width		512 pixels		
Display Format		Single		
Coordinates				
Y-Axis Coordinates		Maq (dBm)		
Units				
Peak or RMS		RMS		
V or V ²		Volt ²		
Scale				
Active Trace		A		
X Magnify Reference	E1430: 2.000000 MHz E1437: 4.000000 MHz			
X Magnify	1			
Y Reference	10 dBm			

Type of Preset	Function	Default Value
	Y Range	100 dBm
	Annotation Setup	
	Title	Hewlett Packard 3587S Realtime Signal Analyzer
	Annotation	Off
	Line 1 ¹	
	Line 2 ¹	
	Vertical ¹	
	Markers	
	Marker Mode	Off
Measurement Setup	Input Setup	
	Input Range	10 dBm
	Coupling	DC
	Grounding	Single-ended
	Analog Ftr	In
	Data Width	32-bit
	External Ref Setup	
	Ref Freq	Internal
	Ext Ref Freq	E1430: 10.24000 MHz E1437: 20.48000 MHz
	Trigger	
	Trigger Mode	Freerun
	Trigger Level	0% FS (full scale)
	Trigger Magnitude Level	-24 dBFS
	Trigger Slope	Positive
	Trigger Delay	0 Samples
	Arm	Auto
	Measurement	
	Measurement Results	
	Spectrum	On
	Time	Off
	Amplitude	Off
	Measurement Parameters	
	Freq Window	Hann
	Overlap	0%
	Histogram Bins	201
	Hist Start V	-1.0000 V
	Hist Stop V	1.0000 V
	Frequency Setup	
	Start Frequency	0.000000 Hz
	Stop Frequency	E1430: 4.00 e6 E1437: 8.00 e6
	Center Frequency	E1430: 2.00 e6 E1437: 4.00 e6
	Span Frequency	E1430: 4.00 e6 E1437: 8.00 e6
	Zoom Mode	Off
	Bandwidth	Full
	Downconvtr Setup	
	Dwn Cnvt LO	0 Hz
	Dwn Cnvt IF	0 Hz
	Freq Mirror	Off
	Freq Multiply	1
	Ampl Scalar	1
	Resolution Setup	
	Resolution	E1430: 5.00 kHz E1437: 10.00 kHz
	Time Length	E1430: 200 sec E1437: 100 sec

Type of Preset	Function	Default Value
	Averaging Setup	
	# Averages	10
	Average Mode	Off
	Expon Factor	10
	Record/Playback	
	Mode	Off
	Filename	Data
	File Length	10 traces
	File Type	data
	Write Protect	On
	Auto Record	Off
	Record Base	1
	Signal Capture	
	Capture Mode	Off
	Filename	Capture
	Capture Size	65536
Customize Files	Customize	
	Menu System	Default
	Knob Box	X/Y Display
	Button Box	Default
	Keyboard	Default
All	All parameters listed in this table are set to their default values	

¹ The default annotation is the null string (no text).

Appendix D: Image Enhancement Convolution Kernels

This appendix contains the convolution kernel definitions referred to in the discussion of Image Enhancement on page 38.

Low-Pass Spatial Filters						High-Pass Spatial Filters											
1/9	1/9	1/9	0.1	0.1	0.1	1/16	1/8	1/16	-1	-1	-1	0	-1	0	1	-2	1
1/9	1/9	1/9	0.1	0.2	0.1	1/8	1/4	1/8	-1	9	-1	-1	5	-1	-2	5	-2
1/9	1/9	1/9	0.1	0.1	0.1	1/16	1/8	1/16	-1	-1	-1	0	-1	0	1	-2	1
LP1			LP2			LP3			HP1			HP2			HP3		

Blurring Kernel					Matched-Filter Edge Enhancement							
1	1	1	1	1	-1	0	1	-1	-1	-1	-1	-1
1	1	1	1	1	-1	0	1	0	0	0	0	0
1	1	1	1	1	-1	0	1	1	1	1	1	1
1	1	1	1	1	-1	0	1	Horizontal Edges				
1	1	1	1	1	-1	0	1	Vertical Edges				

Laplace Edge Enhancements											
0	1	0	-1	-1	-1	-1	-1	-1	1	-2	1
1	-4	1	-1	8	-1	-1	9	-1	-2	4	-2
0	1	0	-1	-1	-1	-1	-1	-1	1	-2	1
LAP1			LAP2			LAP3			LAP4		

Glossary

This glossary contains definitions of general terms used in this manual. For definitions of specific analyzer functions, refer to the online help text for the HP 3587S Realtime Signal Analyzer. For an introduction to Fourier theory and Fast Fourier Transform (FFT) analyzers, see *Spectrum & Network Measurement* by Robert A. Witte (HP P/N 5960-5718).

Active Trace. For an FFT analyzer, a trace (or set of traces) to which a given parameter is applied. Making a trace active means one parameter can be applied to one trace and a different parameter to another trace.

Aliasing. A phenomenon which can occur whenever a signal is not sampled at greater than twice the maximum frequency component. Causes high frequency signals to appear at low frequencies. Aliasing is avoided by filtering out signals greater than $\frac{1}{2}$ the sample rate.

Anti-aliasing Filter. A low-pass filter designed to filter out frequencies higher than $\frac{1}{2}$ the sample rate to prevent aliasing.

Auto Spectrum. The spectrum display of an FFT analyzer whose magnitude represents the power at each frequency, and which has no phase. RMS averaging produces an auto spectrum.

Averaging. In an FFT analyzer, digitally averaging several measurements to improve accuracy or to reduce the level of asynchronous components (noise). Refer to definitions of RMS, time, and peak-hold averaging.

Band-pass Filter. A filter with a single transmission band extending from lower to upper cutoff frequencies. The width of the band is determined by the separation of frequencies at which amplitude is attenuated by 3 dB (0.707).

Bandwidth. The spacing between frequencies at which a band-pass filter attenuates the signal by 3 dB. In an FFT analyzer, measurement bandwidth is equal to $(\text{frequency span})/[(\text{measurement resolution}) \times (\text{window noise bandwidth factor})]$.

Baseband. A measurement that starts at 0 Hz and collects only the real part of time data. See also, Zoom.

Bin. The measurement resolution of a single data point of a data record.

Block Size. The number of samples used in an FFT analyzer to compute the Fast Fourier Transform. Also the number of samples in a time display. The larger the block size, the better the resolution of the measurement and the longer the measurement time.

CDF (Cumulative Density Function) A measure of the probability that a level equal to or less than a specific level occurred. It is computed by integrating the probability density function (PDF).

Center Frequency. For a bandpass filter, the center of the transmission band. For an FFT analyzer, the frequency that is displayed at the center of the x-axis.

Color Map. A color map is similar to a spectral map except the amplitude is represented both graphically and by way of color. The amplitude scale is divided by color, each color representing a portion of the scale.

Coordinates. Any of a set of two or more magnitudes used to determine the position of a point. For example, Hz and time are x-axis coordinates and dBm and volts are y-axis coordinates. Coordinates may also be real, imaginary, or complex.

Cycle. One complete sequence of values of a periodic quantity.

Decibels (dB). A logarithmic representation of amplitude ratio, defined as 20 times the base ten logarithm of the ratio of the measured amplitude to a reference. dB amplitude scales are required to display the full dynamic range of an FFT analyzer. dBV and dBm readings, for example, are used for terminated systems (i.e., 50 Ω systems). dBV is referenced to 1 V_{rms} and dBm is referenced to 1 mW.

Digital Filter. A filter which acts on data after it has been sampled and digitized. These filters are often used in FFT analyzers to provide anti-aliasing protection after internal re-sampling.

FFT Analyzer. A signal analyzer that uses digital signal processing and the Fast Fourier Transform to display frequency components. Results can also be displayed in the time domain, phase spectrum, and amplitude domain.

Flat Top Window. A window function that provides excellent amplitude accuracy, but has less-accurate frequency resolution than the Hanning window.

Frequency. The repetition rate of a periodic event, usually expressed in cycles per second (Hz), revolutions per minute (rpm), or multiples of a rotational speed (orders).

Frequency Hopping. A modulation technique which employs switching of transmitted frequencies at a rate less than or equal to the sampling rate of the information transmitted. Selection of the particular frequency to be transmitted can be made from a fixed sequence or from a pseudo-random set of frequencies covering a wide bandwidth. The intended receiver "frequency-hops" in the same manner as the transmitter to retrieve the desired information.

Gaussian Window. A window function which is especially useful for measuring pseudo-random signals such as those in speech analysis.

GaussTop Window. A window function that has excellent sidelobe performance, and is therefore useful for measurements requiring high dynamic range.

Hanning Window. A window function that provides better frequency resolution than the flat top window, but with reduced amplitude accuracy.

Hardcopy. A printout of data or other information.

Harmonic. Frequency component at a frequency that is an integer multiple of the fundamental frequency.

Hertz (Hz). The unit of frequency represented by cycles per second.

High-pass Filter. A filter with a transmission band starting at a lower cutoff frequency and extending to (theoretically) infinite frequency.

Histogram. A measurement of the number of samples which occur over a given period of time that have amplitudes within a specified interval of amplitudes. The x-axis of a histogram displays a specified range of amplitudes. The y-axis displays the number of times each amplitude occurred over the given time period.

Hysteresis. Non-uniqueness in the relationship between two variables as a parameter increases or decreases. Also called deadband, or that portion of a system's response where a change in input does not produce a change in output.

Integration. The area between two specified points under a curve which produces a result that, when differentiated, yields the original quantity.

Leakage. In FFT analyzers, a result of finite time record length that results in smearing of frequency components. Its effects are greatly reduced by the use of weighted window functions such as flat top and Hann.

Low-pass Filter. A filter whose transmission band extends from dc to an upper cutoff frequency.

Modulation, Amplitude (AM). The process where the amplitude of a signal is varied as a function of the instantaneous value of another signal. The first signal is called the carrier, and the second signal is called the modulating signal. Amplitude modulation produces a component at the carrier frequency, with adjacent components (sidebands) at the frequency of the modulating signal.

Modulation, Frequency (FM). The process where the frequency of the carrier is determined by the amplitude of the modulating signal. Frequency modulation produces a component at the carrier frequency, with adjacent components (sidebands) at the frequency of the modulating signal.

Overlap Processing. When the time required to collect a block of data is greater than the time spent processing it in the FFT, the FFT processor has some idle time. Overlap processing utilizes the idle time by performing FFTs with some "old" data. The amount of overlap is described as a percent: 50% means that half the data in the block is "old" and 100% means that an FFT is performed every time a new sample is taken. Overlap processing improves resolution, greatly increases the speed with which device adjustments can be made, and can dramatically reduce the time needed to compute RMS averages with a given variance. See page 66.

Overshoot. In the display of a step function (usually of time), that portion of the waveform which, immediately following the step, exceeds its nominal or final amplitude.

Panning. Moving the displayed x-axis scale so that adjacent portions of a data record are displayed.

PDF (Probability Density Function) A measure of the probability that a specific level occurred. PDF is a histogram which is normalized to unit area.

Peak Hold. In an FFT analyzer, a type of averaging that holds the peak signal level for each frequency component.

Period. The time required for a complete oscillation or for a single cycle of events. The reciprocal of frequency.

Phase. A measurement of the timing relationship between two signals, or between a triggering point and an event on one signal.

Power Spectrum. The spectrum display of an FFT analyzer whose magnitude represents the power at each frequency, and which has no phase.

Random Window. See Hanning Window.

Real Time Analyzer. See FFT Analyzer.

Real Time Rate (Real Time Bandwidth). For an FFT analyzer, the most broad frequency span at which data is sampled continuously. Real time rate is mostly dependent on FFT processing speed and display speed.

Record. See Time Record.

Rectangular Window. See Uniform Window.

Resolution. The smallest change in stimulus that produces a detectable change in the instrument output.

Ringling. For pulse transmissions, the maximum amount by which the instantaneous pulse value deviates from the straight-line segment fitted to the top of a pulse, following rolloff or overshoot.

Root Mean Square (rms). Square root of the arithmetic average of a set of squared instantaneous values. FFT analyzers perform rms averaging digitally on successive sets of data.

Sidelobe. For a window function, the major lobe contains most of the energy of a signal. This major lobe is at the center of the filter and represents the center of each bin. Energy outside the major lobe is due to a window function's sidelobes. These sidelobes cause energy to appear in other bins.

Signal Conditioner. A device placed between a signal source and a readout instrument to change the signal. Examples: attenuators, preamplifiers, charge amplifiers, filters.

Spectral Map. A three-dimensional plot of the frequency spectrum versus another variable, usually time. This is also commonly referred to as a waterfall plot or display.

Spectrogram. A spectrogram is similar to a spectral map except amplitude is represented by color instead of y-axis fluctuation. The amplitude scale is divided by color, each color representing a portion of the scale.

Spectrum Analyzer. An instrument which displays the frequency spectrum of an input signal.

Subharmonic. Sinusoidal quantity of a frequency that is an integral submultiple of a fundamental frequency.

Time Record. In an FFT analyzer, the sampled time data converted to the frequency domain by the FFT. The size of this time record is sometimes variable, providing variable resolution displays.

Tracking Filter. A low-pass or band-pass filter which automatically tracks the input signal. A tracking filter is usually required for aliasing protection when data sampling is controlled externally.

Transducer. A device for translating the magnitude of one quantity into another quantity. For example, an accelerometer is a transducer that translates motion to voltage.

Trigger. Any event which can be used as a timing reference. In an FFT analyzer, a trigger can be used to start a measurement.

Uniform Window. In an FFT analyzer, a window function with uniform weighting across the time record. This window does not protect against leakage, and should be used only with transient signals contained completely within the time record.

Vector. A quantity which has both magnitude and direction (phase).

Waterfall Plot. See Spectral Map.

Window Function. A weighting function applied to a time record to overcome the problem of leakage. Most window functions force the time record values to zero at each end of the time record to reduce or eliminate the transient that otherwise occurs when the record is replicated, as is done in FFT analysis. The shape of the window is important because it changes the data values. Various functions have been developed for particular DSP applications. The common ones are Hanning, flat top, Gaussian, Gaussstop, and uniform.

Zoom. A measurement with a start frequency that is greater than 0 Hz and collects both the real and imaginary parts of the time data. See also, Baseband.

Index

A

- A trace 42
- accelerator keys 108
- active trace 42, 119
- aliasing 119
- All Traces 42
- amplitude
 - domain 49
 - error 62
- annotation 50
- anti-alias filter 119
- application window 5
- archiving throughput files 91
- arm
 - manual 85
 - trigger 78
- auto
 - record 85
 - scale 24, 60
 - spectrum 119
- available disk space 99
- averaging 56, 74
 - definition 119
- azimuth 32

B

- B trace 42
- backup, throughput files 91
- bandwidth
 - definition 119
 - noise 62
 - real-time 67
- baseband 68
 - definition 119
- batch plotting 54
- bin
 - definition 119

- histogram 49
- Blackman window 62
- block
 - diagram 80
 - mode 66
 - size 119
- blurring
 - image enhancement 39
 - kernel definition 118
- buffer depth 83
- button box
 - active status 13
 - functions 106
 - installation 11
 - introduction 4
 - notation 7

C

- C trace 42
- capture 81
 - mode 85
 - mode recall 86
 - save unprocessed data 84
- CDF 49, 119
- center frequency 72, 119
- changeable parameters 80
- changing
 - active trace 42
 - amount of overlap processing 66
 - frequency span 61
 - map color scaling 36
 - map colors 34
 - y-axis coordinates 70
- codewords 13
- collecting data 79
- color distribution
 - See color scaling

- color map
 - changing color scale 36
 - changing map color 34
 - displaying 32
- color scaling 36
- color setup
 - See Also map color
 - presetting 57
- command switches 15
- common terms
 - See glossary
- compatible printers 52
 - See Also Customization Guide
 - See Also printing to other printers
- complex data 72
- configuration
 - files 13
 - hardware 10
- contoured map
 - See wire frame
- convolution kernels
 - blurring kernel 118
 - Laplace edge enhancement 118
- coordinates
 - complex 68, 72
 - definition 119
 - y-axis 70
- copy
 - capture data files 103
 - saved capture data 103
 - trace data files 102
- cumulative density function (CDF) 49, 119
- customize files
 - See Also Customization Guide
 - presetting 57

D

- dark range stretching 36
- data
 - archiving 83
 - collection 79, 81 - 83
 - copying 103
 - display 82
 - extraction 82
 - post-processing 81, 83
 - records 44
 - reduction 82

- SDF 83
 - types 80
- data header state 96
 - keyboard accelerator 108
- date and time 92
- delay, trigger 78
- delete files 104
- directory 15
- disk space 99
 - amount used 99
 - maximizing 95
- display
 - data 80, 82
 - memory size 83
 - preset 57
 - printing 52
 - rate 40
 - state information 96 - 97
- displaying
 - color maps 32
 - cumulative density function 48
 - disk space 99
 - frequency spectrums 23
 - histograms 48
 - instrument state 97
 - marker(s) 27
 - online help 20
 - probability density function 48
 - real and imaginary coordinates 72
 - saved data 86, 93 - 94
 - spectral maps 40
 - spectrograms 28, 30
 - strip charts 44
 - titles and annotations 50
- downconverters
 - hardware installation 11 - 12
- dual trace 44

E

- edge enhancement 39
- editing annotation 50
- elevation 28, 30, 32, 38
- enhancing images 38
- exit
 - See system shutdown
- exponential averaging 74
- extracting data 82

task 90

F

file

- copying 102 - 103
- date and time 92
- deleting 104
- moving/transferring 92
- permissions 92
- system directory structure 92
- system information 99

flat top window 62, 119

format, data 83

free run trigger 77

FREQ WINDOW 62

frequency span 61

front end hardware

installation 11

presetting 57

function definitions

See online help

functions

button box 106

knob box 107

G

gap indicator 66

gap-free data acquisition

See signal capture

Gaussian window 62, 120

Gausstop window 62, 120

glossary 119

grid 42

H

Hanning window 62

definition 120

hard disk usage 99

help index 7, 20

printing 53

HF tuner 11

hidden line 40

high-pass image enhancement 39

histogram 49

color map 49

definition 120

length 49

map 49

horizontal edge enhancement 39

HP LASERJET 52

I

image enhancement 38

convolution kernels 118

imaginary

coordinates 72

data 68

index

for help 20

input

range, preset 115

setup, preset 115

state 96

Installation

See Also HP 35687A Software Installation Note

installed

options 13

instrument state

appending to a printout 52

displaying 97

printing 53

saving and recalling 97

K

key path 20

keyboard

accelerators 22

installation 11

introduction 5

notation 7

user's guide 105

knob box

active status 13

installation 11

introduction 4

notation 7

knob box functions 107

knob sensitivity 13

L

Laplace edge enhancement 39, 118

leakage 56, 62, 120

- LIF file
 - archive 91
 - system 81
- light range stretching 36
- lines, number of 64
- listing
 - the instrument state 97
- log factor (colors) 36
- low-pass image enhancement 39

M

- magnify x axis 64
- main marker 27
- map angle
 - See azimuth
- map color
 - changing color scaling 36
 - changing colors 34
 - dark and light range stretching 36
- map colors
 - mode 36
- marker
 - accelerator keys 108
 - knob functions 107
 - relative 27
 - single 27
 - speed keys 106
 - strip chart 46
 - to center frequency 108
 - trace 30
 - units 70
- matched-filter edge enhancement 118
- maximum display rate 40
- measurement
 - marker 27
 - online 58
 - preset 57
 - resolution 64
 - speed improvements 66
 - state 96
 - zoom 68
- measurement state 96 - 97
 - displaying 22
 - keyboard accelerator 108
- median filtering 39
- memory
 - allocated for data 15

- configuration 83
 - preset 57
- menu map
 - knob box 107
 - printing 53
- modifying
 - x-axis scale 26
 - y-axis scale 24
- monitor
 - controls 60
 - installation 11
- mouse
 - installation 11
 - introduction 4
 - notation 7
- moving
 - files 92
 - markers 107

N

- NEXT PEAK LEFT
 - keyboard accelerator 108
- next peak right 27
- NEXT PEAK RT
 - keyboard accelerator 108
- noise equivalent bandwidth factor 62
- Nth Averaging 74
- Number of Lines
 - See resolution

O

- online
 - help 20
 - measurement indicator 58
- options
 - available 6
 - descriptions 6
 - installed 13
- overlap processing 66, 120
- overload
 - indicator 58
 - status 100

P

- panning the display 26
- PDF 49, 120

- peak averaging 74, 120
- playback 22
 - signal capture file 86
- playing back a stored record 22
- post-processing
 - captured data 86
 - data 81
 - task 88 - 89
- power
 - magnitude 77
 - spectrum 120
- power-off procedure 14
- power-up defaults 15
- preset 57
- print
 - mode 52
 - screen 52
- printer type 52
- printing 52
 - batch 54
 - color displays 53
 - data 52
 - full screen 52
 - help index 53
 - instrument state 53
 - keyboard accelerator 108
 - menu maps 53
 - multiple data sets 54
 - other printers 53
 - trace area 52
- probability density function (PDF) 49, 120

Q

- quit
 - See system shutdown

R

- random window
 - See Hanning
- range, input 60
- real coordinates 72
- real-time bandwidth 67, 120
- recall
 - captured data 86
 - display data 93
 - signal capture file 86

- state information 98
- the instrument state 97
- trace data file 83
- record
 - and play back display data 94
 - keyboard accelerator 108
 - signal capture data 85
- rectangular window
 - See uniform
- reducing data 82
- refresh rate 61
 - improving 66
- relative marker 27
- resolution 64
- RMS Averaging 74
- rollogram 28 - 29

S

- SATURATION 34
- save
 - data 83
 - display data 93
 - signal capture file 85
 - single trace 95
 - state 97
 - state information 98
- save data 83
- scaling
 - synchronize traces 108
 - x-axis 26
 - y-axis 24
- screen
 - introduction 5
 - printing 52
- scroll 29 - 30, 95
 - direction 40
 - traces 108
- SCSI disks 81
- SDF 83
- sensitivity, knob 13
- shutdown power 14
- signal capture 81, 85
 - recalling 86
 - saving 85
- signal capture data 80 - 81
- signal flow diagram 80
- single marker 27

- sinusoidal window
 - See flat top
- slide bar controls 24, 60
- slope, trigger 78
- softkey settings 42
- span 61
- spatial filters 118
- spectral map
 - definition 121
 - displaying 40
- spectrogram
 - changing color scale 36
 - changing map color 34
 - description 121
 - displaying 30
- speed keys
 - See keyboard accelerators
- state 97
 - information 96
 - printing 52
- statistical functions
 - See amplitude domain
- status
 - gap 46
 - printer 52
- stretching (color map scale) 36
- strip chart 44
- synchronize traces 108
- system
 - block diagram 80
 - shutdown 14
- system configuration
 - files 13
 - hardware 10

T

- terms (common)
 - See glossary
- threshold 32, 40
- throughput capture
 - data 81
 - file backup 91
 - task 87
- throughput capture data 80
- time
 - data 44, 81, 88
 - length 64

- time record length 64
- title 50
- trace
 - marker 30
 - printing 52
 - spacing 28, 30, 32
 - state 96
 - state, accelerator 108
 - synchronize scales 108
- trace only (print) 52
- transfer files between disks 92
- transient window
 - See uniform
- trigger 78
 - conditions 76
 - definition 121
 - delay 78
 - magnitude level 78
 - manual arm 85
 - slope 78
- triple trace 46
- tuners 11

U

- uniform window 62
 - definition 121
- using the marker 27
- using the strip chart markers 46

V

- vertical edge enhancement 39
- VHF/UHF tuners 11
- viewing consecutive traces 29 - 30

W

- waterfall
 - See spectral map
- window
 - application 5
 - function, definition 121
 - functions 62
 - size, position, name 13
- wire frame 40
- working directory 15

X

X axis

breakpoint 36

magnify 26

reference 26

X magnify 40

x-axis

scaling 26

Y

Y axis

auto scale 24

breakpoint 36

range 24

reference 24

y-axis

coordinates 70

scaling 24

Z

zoom measurements 56, 68

definition 121

post-processing 88