

USER GUIDE
for the
SFC FUSION™ A5 Module



© Aurora SFC Systems, Inc. 2009

No part of this manual may be reproduced in any form or by any means (including electronic storage and retrieval or translation into a foreign language) without prior agreement and written consent from Aurora SFC Systems, Inc. as governed by United States and international copyright laws.

P/N A5-53-3000 Rev A

11/09

Printed in the United States

The material contained in this document is provided “as is,” and is subject to being changed, without notice in future editions. Aurora SFC Systems shall not be liable for errors or for incidental or consequential damages in connection with the furnishing, use, or performance of this document or of any information contained herein.

Technology Rights

The SFC Fusion™ technology described in this manual is covered under one or more US and international patent applications and is owned exclusively by Aurora SFC Systems, Inc. A limited license is granted Aurora customers to use the technology in accordance with the manufacturer’s guidelines and exclusively with Aurora hardware unless otherwise specified in writing by Aurora SFC Systems. Improper or unapproved use may, at Aurora’s discretion, revoke the use license and be prosecuted to the fullest extent of the law.

Trademarks

SFC Fusion and Aurora SFC Fusion are trademarks of Aurora SFC Systems, Inc. All rights reserved.

Technical Contact Information

Aurora SFC Systems, Inc
1250 Oakmead Pkwy
Suite 210
Sunnyvale, CA 94085
USA

info@aurorasfc.com

877.TRY.SFC1
(877-879-7321)
650.636.9390

Safety Notices and Symbols

CAUTION

A **CAUTION** notice denotes a hazard. It calls attention to an operating procedure, practice, or the like that, if not correctly performed or adhered to, could result in damage to the product or loss of important data. Do not proceed beyond a **CAUTION** notice until the indicated conditions are fully understood and met.

WARNING

A **WARNING** notice denotes a hazard. It calls attention to an operating procedure, practice, or the like that, if not correctly performed or adhered to, could result in personal injury or death. Do not proceed beyond a **WARNING** notice until the indicated conditions are fully understood and met.

NOTICE

A **NOTICE** is an application specific, extended description of a product feature or operation. It may be used to explain alternative or extended means of use; to emphasize specific features or to explain specific exceptions to general guidelines.



This symbol signifies risk of electric shock hazard. Application of the symbol on a product surface requires operators to consult the product documentation for a full explanation of the hazard. The documentation will display the symbol as part of the **WARNING** or **CAUTION** hazard description.



This symbol signifies a hot surface hazard. Application of the symbol on a product surface requires operators to consult the product documentation for a full explanation of the hazard. The documentation will display the symbol as part of the **WARNING** or **CAUTION** hazard description.



This symbol signifies a mechanical pinch hazard. Application of the symbol on a product surface requires operators to consult the product documentation for a full explanation of the hazard. The documentation will display the symbol as part of the **WARNING** or **CAUTION** hazard description.

TABLE OF CONTENTS

Technology Rights	2
Trademarks	2
Technical Contact Information	2
Safety Notices and Symbols	3
TABLE OF CONTENTS.....	4
Chapter 1 SFC Fusion A5 Module Overview.....	9
Product Description	9
Intended Use	10
Module Layout.....	11
The Electronics Bay	14
The BPR Drawer.....	17
The Booster Drawer	19
Safety Features.....	21
Protective Grounding	21
Double Fused Power Entry Module.....	21
APG Remote Connection.....	22
Liquid Leak sensor.....	22
Chiller hardware current limit.....	22
Normally closed CO2 supply valve	22
Pump and fan index monitoring.....	22
Booster Motor and Injection Wash motor index monitoring.....	23
Back Pressure Regulator Drive Home Sense.....	23

CPU Watchdog timer	23
System Pressure monitoring	23
System Temperature Monitoring	24
Inactivity Timeouts	24
Readiness timeout	25
Power Supply Monitoring.....	25
System Logbook	25
Chapter 2 Site Requirements and Specifications	26
Physical and Facility Requirements.....	26
Overview.....	26
Customer Responsibilities	27
Ventilation.....	28
Environmental Conditions	29
Bench Space.....	30
Dimensions and Weight.....	31
Electrical	31
Gas Supply Selection	32
Cylinder Storage.	33
Flammable Solvents.....	33
HPLC Requirements	35
PC and Software Requirements	36
Summary of SFC Fusion A5 Specifications	37
Chapter 3 Installing the SFC Fusion A5	39

Hardware Installation.....	39
General Procedures	39
Preparing the HPLC.....	40
Modifications to the Agilent Binary Pump.....	42
Modifications to the Agilent Autosampler	48
Installing SFC Fusion A5.....	59
Preparation	59
Unpacking the Fusion A5	59
Connecting the Waste system to the Fusion BPR Outlet.....	61
Installing the Flowcell.....	63
Connecting the BPR to the HPLC Stack.....	64
Optimized Oven Plumbing	65
Connecting The Autosampler	66
Connecting Booster To HPLC	66
The Injector Wash Pump	68
Priming the Injector Wash Pump.....	70
Connecting Fusion A5 to a Source of Carbon Dioxide	70
Cable connections to the HPLC.....	74
Getting Ready to Run the Instrument	77
Software Installation	79
Installing SFC Fusion™ Driver Software.....	79
Installing the SFC Fusion™ A5 USB driver	83
Configuring the CIC driver interface in ChemStation.....	87

Chapter 4 Operating the SFC Fusion A5	93
Powering on the Module	93
Power Up Sequence and Operational Control States	93
Operational Control States	94
Controlling the A5 through the Agilent Chemstation™	96
User Interface Familiarization	96
Exploring the A5 module Graphical User Interface (GUI)	97
Turning the SFC System on and off	99
Starting and Stopping the A5 Module	100
Controlling the Wash Pump	101
Viewing A5 Charting Functions	102
Running a method on the SFC system	103
Loading the SFC_Def analysis method	103
Adjusting the method for use	103
Running the Checkout Method	104
Shutting Down the SFC	106
Partial Shutdown	106
Full Shutdown	107
Chapter 5 Maintaining the SFC Fusion A5	109
Inspection and Preventative Maintenance Intervals	109
Daily Inspection and Maintenance	109
Every 3 months	109
Every 6 months	Error! Bookmark not defined.

Annually.....	110
As Needed [Corrective]	110
General Maintenance procedures.....	111
Booster Drawer	111
Replacing Fuses	116
Cleaning and Decontamination.....	117
Preparing for storage or shipping.....	118
APPENDIX.....	120

Chapter 1

SFC Fusion A5 Module Overview

Product Description

The SFC Fusion™ A5 module is an add-on accessory to specific configurations of existing Agilent 1100 or 1200 series HPLC systems. The A5 module performs several functions which in combination allow the host HPLC system to meter liquid or supercritical CO₂ as one of the components of a high pressure binary fluid pumping system. From the host pump's perspective the CO₂ is pumped in much the same manner as water is pumped in reversed phase HPLC. When pumping CO₂, the separation system is typically referred to as a *Supercritical Fluid Chromatography* [SFC] system.

The A5 module itself is not a separation system. It simply provides pre- and post-flow conditioning features that insure the CO₂ remains a well behaved fluid during the separation process. On the pre-flow end, the A5 module conditions incoming CO₂ vapor or liquid by precompressing and thermally conditioning the flow stream such that the Agilent pump can meter the fluid with little or no compression compensation. The result is a continuous, nearly pulsation-free stream of CO₂ from the metering pump that in turn produces a much lower baseline noise to optical detectors in the system.

Installation of the A5 module requires very minor alterations of the existing HPLC hardware and software. Further, normal HPLC function can be restored simply by replacing the CO₂ supply with a standard liquid supply with the hardware enhancements in place. As a result, the conversion between HPLC use and SFC use and back is rapid.

The SFC Fusion module is designed to minimize the need for significant linear benchspace in laboratories. The tall narrow aspect of the module requires less than 10 inches of linear space.

Once installed, the SFC Fusion A5 software driver integrates directly into the Agilent ChemStation graphical user interface. Users are provided access to method setpoints and instrument control. A visual display of instrument parameter status is also available. In all other ways, the ChemStation software remains identical to HPLC operation.

Additional off-line diagnostic software provided with the A5 module allows users to run a full suite of diagnostic tests to indicate module performance. Many tests can be run either on the module alone, or on the complete system.

Intended Use

The SFC Fusion A5 Module is intended for use by qualified operators only in climate controlled, well ventilated chemical laboratory environments as part of a larger chromatography system. Operation of the A5 module preconditions an output CO₂ flowstream for input to the larger chromatography system, allowing the system pump to deliver a precisely metered volumetric flow rate. CO₂ is the only chemical fluid permitted for use in this preconditioning step. Allowed hardware configurations of the larger chromatography system are available from Aurora SFC Systems and may change over time.

CO₂ flowstreams as well as any modifier flowstreams added to the chromatographic mobile phase must be substantially returned to the A5 module back pressure regulator after the detector(s) of the system for proper system operation. The outlet vapor/liquid flow stream of the BPR should be separated by phase with the vapor phase directed to a dedicated ventilation path and not released into the general laboratory air system.

Operators of the A5 module should read all documentation included in this manual and be aware of safety considerations. In particular, operators must be aware of standard operation, inspection and maintenance procedures of the module.

Stand alone operation of the A5 module as a CO₂ delivery system is prohibited except for diagnostic purposes under control of diagnostic software tools provided by Aurora SFC Systems. Such prohibited use will void the manufacturer's warranty and may result in unsafe operation.

WARNING	Use of this product outside the specific operational guidelines of this manual will invalidate the Warranty and may result in hazardous operation and revoke the limited use license granted for SFC Fusion technology.
----------------	--

Module Layout

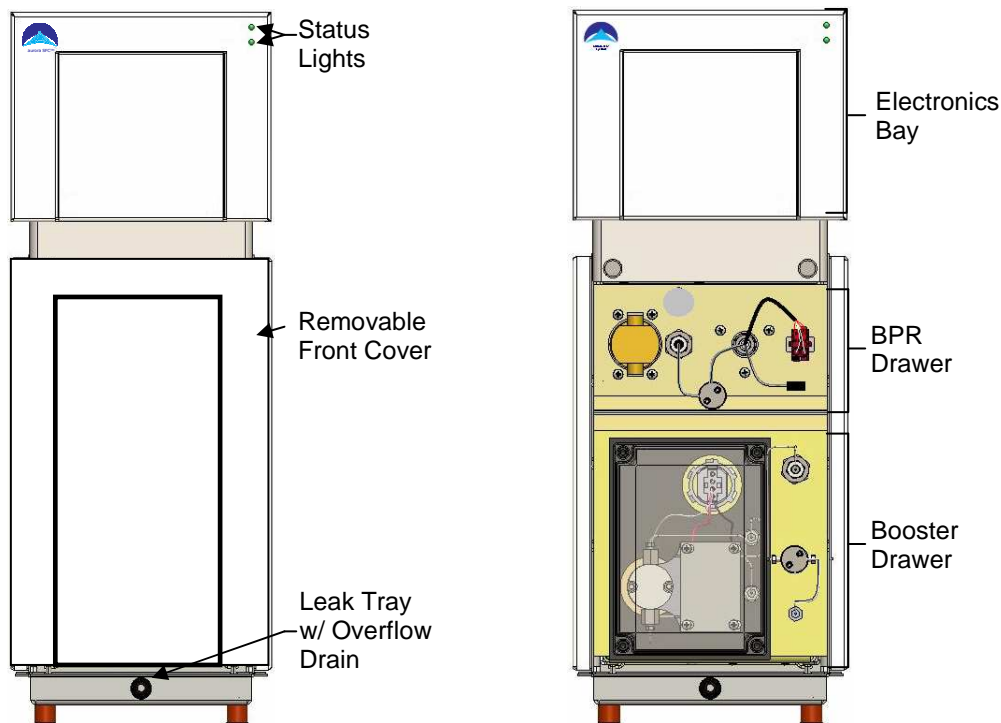

Figure 1.1
The SFC Fusion A5 module

Figure 1.1 shows two illustrations of the front view of the A5 module. The SFC Fusion Module consists of several integrated sections which include:

- A protective external enclosure with removable front cover
- An electronics bay
- A back pressure regulator (BPR) drawer
- A booster drawer
- A leak tray with overflow drain

The A5 module is intended to be located immediately to the right or left of the Agilent HPLC stack and share use of the Agilent solvent compartment for wash solvent and waste bottle containment. In cases where additional detectors such as MS or ELSD are located adjacent to the HPLC stack the A5 module should be preferentially located to the opposite side.

The Enclosure

The SFC Fusion A5 enclosure [Figure 1.2] protects internal module components from damage during shipping and normal operation of the module. The enclosure consists of an internal frame used to support three bays of the module and external panels and covers used to isolate the internal components. All panels and covers should remain installed during normal operation of the instrument.



The base of the enclosure supports a stainless steel drip tray intended to capture unintentional fluidic leaks resulting from plumbing, priming and improper tightening of fittings or from condensate that may accumulate in the module. The drip tray contains an electronic leak sensor encased in a Teflon shell used to detect accumulation of fluid in the tray and signal an alert. The sensor will respond to laboratory fluids typically used in the system including wash solvents, modifiers and water. The drip tray also includes an overflow port to allow excess fluid to be channeled via a supplied drain tube to an appropriate waste container provided by the user.

A removable front panel provides users access to the lower two bays which support the BPR and Booster drawers. Removal of the panel is performed by grasping the top left and right corners of the panel and pulling gently forward to release the magnetic clasps, then lifting the panel clear of the bottom locating pins. With the front panel removed, the user has access to all the user serviceable components of the module with the exception of the CO₂ inlet port and electrical connections located on the rear panel of the enclosure. Except under very special circumstances, there is no need to remove the enclosure side panels for routine operation or maintenance. Doing so may damage delicate internal components and void the module warranty. In addition, removal of side covers may expose users to unguarded moving parts such as fans, motors or belt drives that represent a mechanical hazards.

WARNING



Removal of side covers will expose users to unguarded moving parts that represent mechanical hazards. In addition, this may expose delicate internal parts to damage. Warranty may be voided if user opens these panels without specific factory authorization.

Fluidic transfer lines into and out of the A5 module are routed through “T” shaped access cutouts in the enclosure side panels. This routing allows the front panel to be replaced after installation without crimping or twisting of the transfer lines.

Figure 1.x shows the bottom rear view of the enclosure. Located at the bottom left of this figure is a CO2 inlet port. The port accepts a six foot 1/8" OD stainless steel transfer line supplied with the A5 ship Kit and intended to introduce CO2 vapor from high pressure CO2 cylinders or CO2 liquid from a high pressure CO2 delivery system. The inlet port contains a cup style filter intended to remove any solid particulates introduced with the CO2 down to 10 um in size. The cup filter is user replaceable and the reorder number is available in the table of consumables located in the Appendix.

Figure 1.3 also shows a fan guard intended to protect a radiator based, circulated cooling system of the booster drawer. Cool air is drawn into the module via this fan guard to help sustain the drawers CO2 chiller operation. Airflow into the vent must not be obstructed. Locating this vent near the hot exhaust of another instrument in the laboratory will decrease the chilling efficiency of the chiller and will likely result in a higher maintenance frequency. Sharp objects should never be poked into the holes of the guard since this will damage the radiator or fan assemblies of the cooling system.



Figure 1.3
Rear view of lower section
of the A5 Enclosure

The Electronics Bay

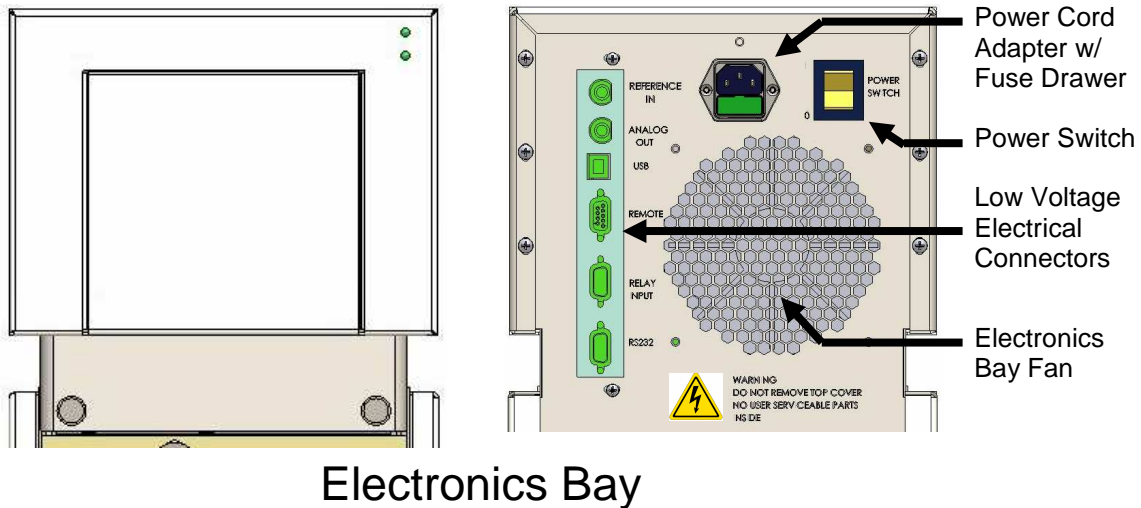

Figure 1.4
Front and rear view illustrations of the A5 Electronics Bay

The electronics bay of the A5 module houses power supplies, fans and mainboard electronics used to power and control the module. The bay is isolated from user contact by the enclosure top cover. This cover should never be removed by the user. Removal will expose the user to high voltages required to power the device. Within the electronics bay, 120V or 240 V AC supply power is converted to 12V or 24V DC power sources which are distributed throughout the module to power motors, fans, sensors and pumps as well as mainboard electronics. Use of low voltage DC power dramatically reduces shock hazard to users in the event of equipment damage or malfunction.

WARNING



Removal of the top cover will expose the user to high voltages required to power the module. No user serviceable parts are enclosed. The top cover should never be removed by the user, but only by a qualified service technician. A serious shock hazard exists if the power cord is attached and the top cover is removed. This is true whether the unit is powered on or off. As a safety measure always remove the power cord before removing the top cover.

The top front cover of the electronics bay houses two status lights in the upper right corner. These lights are used to convey the operational state of the module. In general, illumination of the top light signals that the module has been powered while illumination of the bottom light signals the module has reached a “ready” state of operation. Two other modes of signaling are used by the status lights to signal other module states. The two lights flashing in an alternating pattern [i.e. one light on then the other] signals the device is in “standby” mode. Both lights flashing on then off at the same time signals an

error event of the module. The user is responsible for correcting and clearing error conditions before attempting to restart the module for normal operation. A detailed description of the different operating control states of the A5 module is offered in Chapter 4.

The right illustration of Figure 1.5 displays a rear view of the electronics bay. A panel mounted C14 (10A) filtered power entry module which conforms to industry standard IEC-60320 specifications is located in the upper center of the diagram. The receptacle requires a mating C-13 terminated power cord. A US power cord conforming to the NEMA 5-15P specification is included in the A5 ship kit. This power cord allows connection to US standard 120V 15 amp AC circuits via a plug in wall receptacle. The A5 module itself can accept AC power in the range of 100 – 240 V at 50-60 Hz. Users operating the A5 module in other countries are responsible for supplying a suitable power cord with appropriate termination. The power receptacle contains a dual fuse drawer in conformance with IEC 61010 safety standards. Fuses are user replaceable according to the maintenance procedure found in the Chapter 5.

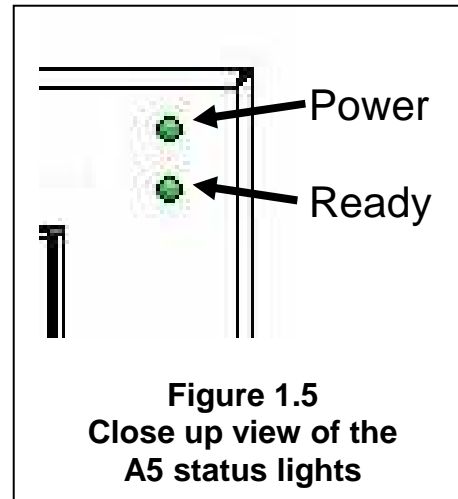

To the right of the power receptacle is a rocker type power switch. Depressing the bottom of the power switch turns the unit to the OFF or unpowered state. Depressing the top of the power switch powers the A5 module. Except for diagnostic testing and certain plumbing maintenance procedures, all maintenance performed on the A5 module should be performed with the power switch in the OFF position.

To the left side of the rear view figure [i.e. on the module's rear right side] is a bezel which provides a series of low voltage electrical connections. These connectors are labeled as follow and are briefly described below:

- **Reference In.** This connector uses a BNC type cable to connect to the analog out BNC connector of the Agilent Binary Pump.
- **Analog Out.** This connector is reserved for special applications of the A5 module.
- **USB.** This connector mates to the B side of a supplied USB cable. The cable is then connected to the PC workstation at an available USB 2.0 port.
- **Remote.** This connector uses a supplied DE9 m/m cable and connects to the Remote port of the Agilent autosampler. In the event that a CTC autosampler is used, the CTC and the A5 module connect to the “Remote” port of the Agilent binary pump via a Y cable.
- **Relay Input.** This connection is used only if the wash pump is installed. The supplied DE15 cable connects to the BCD accessory interface installed in the Agilent autosampler during system setup.

- **RS232.** This connector is reserved for special applications the A5 module. It is not equivalent to or a suitable replacement for the USB connector for communication to the Workstation PC.

Installers should use only the cables supplied with the A5 for connection of these analog and digital signals. If a particular cable is lost or damaged, a replacement cable should be ordered from Aurora SFC Systems. Care should be taken in inserting cables into connectors. Damage to connectors on the bezel will result in replacement of the mainboard of the module.

WARNING	Only cables supplied with the SFC Fusion A5 module should be used. Use of other cables may result in violation of IEC or NRTL compliance specifications. The A5 module may experience undue susceptibility to external radiated or conducted frequencies.
----------------	--

The BPR Drawer

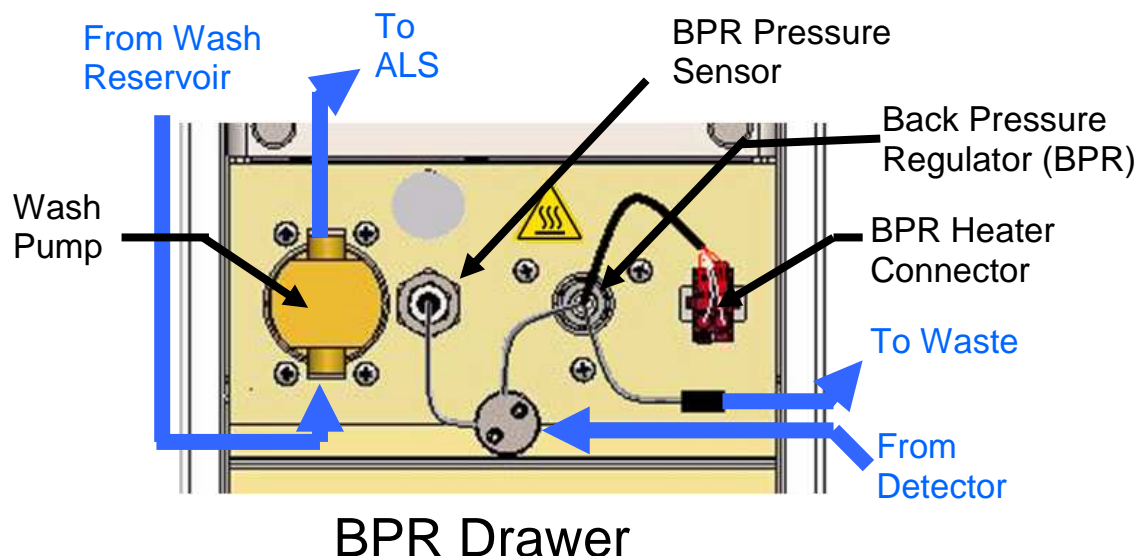

Figure 1.6
Illustration of BPR Drawer components

The BPR drawer houses the system back pressure regulator and optional wash pump assemblies. The function of this drawer is to provide high precision control of the system back pressure independent of pressure setting, flow rate and composition within the operational range of the SFC system. If specific autosamplers are selected during the order process, an optional wash pump is installed in the BPR drawer. The pump provides low pressure solvent to the autosampler to help reduce sample carryover.

The BPR head is heated to promote smooth control and replace heat consumed by the phase change of CO₂ from liquid to gas across the nozzle orifice. The heated control range is 30 to 70 C, however the temperature can exceed the control range during startup, when flow or composition are suddenly changed or if the heater goes into a runaway condition. Open loop temperatures of the BPR head can exceed 120 C. This component should always be considered a hot surface capable of inflicting serious burns to skin. The front cover should always be installed during operation as a safety measure.

WARNING



The BPR head can reach temperatures exceeding 120 C in fault states and should always be considered a serious burn hazard. The front cover should always be installed during module operation as a safety measure.

Figure 1.2 shows the main elements of the BPR and wash pump assemblies. Inlet and outlet flow paths for each are displayed in blue in the figure. Both devices are user serviceable from the front panel of the BPR drawer. The BPR is designed to be

replaceable. In the event of BPR failure, the user disconnects the inlet and out flow lines, unplugs the BPR heater connector and unscrews the BPR head assembly from the front panel. The replacement BPR head is refastened firmly to the panel, plugged into the heater connector and reattached to the inlet and outlet connectors. No calibration of the new BPR head is required. Service to the wash pump includes standard operations such as check valve and seal replacement. Again, all operations are accessible from the front panel of the BPR drawer.

Exchange of the entire BPR drawer assembly is available as a service option, but is outside the scope of this manual. In the event of an exchange, specific instructions will be included with the new drawer for the removal and replacement of the drawer as well as return of the defective drawer assembly.

The Booster Drawer

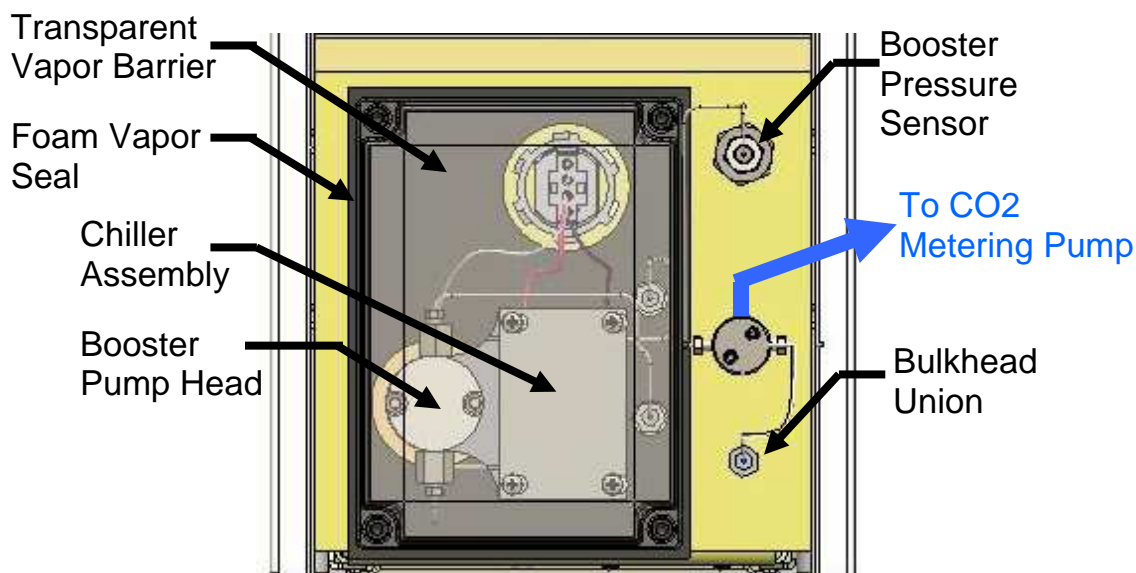

Booster Drawer

Figure 1.7
Illustration of Booster Drawer components
accessible from the front panel

The Booster drawer houses components of the SFC Fusion A5 module responsible for preconditioning the CO₂ to a high pressure liquid state immediately prior to being metered by the HPLC system binary pump. All user serviceable components of the booster drawer are accessible from the front panel of the drawer. These include the booster pump seals and check valves, and in rare cases, the pump piston.

Plumbing in the booster pump is pretested for leaks at the factory. The only fittings that may need adjustment are fittings related to pump head removal; check valve replacement and attachment of the outlet transfer line to the Agilent binary pump. Users should avoid over tightening fittings since this may cause distortion of the bulkhead fittings and require a service call to remove leaks.

The majority of accessible components of the booster pump are located within a transparent shield sealed to the drawer face with a foam seal. The shield and seal act to prevent infiltration of water vapor into the pump head compartment. This is critical since in routine operation, the pump head chiller assembly can reach temperatures as low as -20C. Without an adequate barrier, water vapor would rapidly freeze into a large ice ball at the pump head. Freezing water consumes a great deal of power and dramatically robs the chiller of power necessary to chill incoming CO₂ to the liquid state.

For service operations, the transparent shield is easily removed by removing screws at each corner. Before removal of the shield, the pump unit should be allowed to warm to near room temperature to prevent significant condensation on the metal surfaces. After service, the metal surfaces should be wiped free of any apparent condensation before the shield is replaced. It is not unusual to observe a thin patina of frost coating the chiller plate during operation. This arises from a very small amount of water trapped inside the shield and is not harmful to the booster operation. Observing a growing accumulation of frost inside the shield is an indication of seal failure and should be corrected.

External to the vapor shield are the outlet components of the booster pump. These include a bulkhead union that delivers the conditioned CO₂ to the face surface; a booster outlet pressure sensor and a fluidic tee that splits the flow stream between the dead-ended pressure sensor and the module outlet.

Internal components of the booster drawer include the booster pump drive mechanism; a CO₂ shut off valve; an inlet supply pressure sensor; a pulse dampener; and a radiator-based, circulated liquid cooling system. These components are specifically selected for long term, low maintenance operation and are not part of the user serviceable parts list. Annual maintenance by a qualified service representative is recommended for maintaining these components in good working order.

Exchange of the entire booster pump drawer is available as a service option, but is outside the scope of this manual. In the event of an exchange, specific instructions will be included with the new booster drawer for the removal and replacement of the drawer as well as return of the defective drawer assembly.

The booster pump is capable of prepping CO₂ for sustained flow at rates of up to 5 mL/min and pressures up to 400 bar measured at the Agilent binary pump inlet. Despite the high flow rate and pressures, internal fluidic volumes of the A5 system remain low. Total fluidic volume prior to the booster stage is less than 5 mL, while total fluidic volume after the pressurization stage is less than 25 mL. These stated volumes do not include the volumes contained in the external component of the HPLC system, but do include the return internal volumes of the BPR flowpath as well.

Safety Features

The SFC Fusion A5 module is equipped with several safety features designed to prevent accidental hazardous operating ranges from being achieved when operating as part of a larger SFC System. These features include:

- Protective Grounding
- Double Fused Power Entry Module
- APG Remote Connection
- Liquid Leak Sensor
- Chiller hardware current limit
- Normally closed CO2 supply valve
- Pump and fan index monitoring
- Booster Motor and Injection Wash motor index monitoring
- Back Pressure Regulator Drive Home Sensor
- CPU Watchdog timer
- System Pressure monitoring
- System Temperature monitoring
- Inactivity Timeouts
- Readiness timeout
- Power Supply Monitoring
- System Log Book

Protective Grounding

The SFC Fusion A5 is designed to be powered using a power cord with a protective ground wire. The wire grounds the instrument case and protects users from accidental exposure to high internal voltages used to power the system. The A5 must be installed into a properly grounded outlet before powering the device. Never defeat the grounding path by using ungrounded adapters between the A5 and the power source. This can create an unsafe operating condition.

WARNING

The A5 must be installed into a properly grounded outlet before powering the device. Never defeat the grounding path by using ungrounded adapters between the A5 and the power source. This can create an unsafe operating condition.

Double Fused Power Entry Module

The power entry module of the A5 module is double fused in compliance with IEC and CE safety guidelines. The two 8A 250V time-delayed rated fuses protect the device from external power surges and internal electrical malfunctions and shorts. Spare fuses are supplied as part of the A5 ship kit.. Users should never simply change a fuse without first trouble shooting the cause for failure.

APG Remote Connection

The A5 has a bi-directional signal to monitor for external errors reported by the HPLC system, and to report faults and errors recognized by the A5 to the HPLC.

Should the A5 sense an HPLC reported fault on the Remote Shutdown line (pulled low), the A5 will immediately respond by disabling all drive, control, and CO2 supply. A severe fault recognized within the A5 will result in the same system shutdown, and the Remote Shutdown line will also be signaled to scram the HPLC system as well.

In addition to reporting Shutdown Faults, the remote connection will also continuously report the ready/not ready state of the A5. This allows the HPLC to delay run time events if the A5 is not at ready conditions.

Liquid Leak sensor

The A5 has been designed to contain liquid leaks in the front of the system bulkhead area. Liquid leaks and spills do not enter the area occupied by electronics or motor devices. Below the bulkhead is a drip tray that contains an active leak sensor. Anytime a liquid (leak, condensate, solvent, coolant) migrates beneath the sensor, a leak fault is triggered and the system immediately scrams. The remote shutdown is also signaled and the HPLC will shutdown also.

Chiller hardware current limit

An over-current protection circuit is installed on the chiller drive circuitry. In the event that the chiller electronics draw excessive current, the error will be instantly signaled and current shut off. This will place the system in a not ready state. The A5 will remain in this state until either reset or power cycled.

Normally closed CO2 supply valve

The Fusion A5 is equipped with a normally closed on/off valve on the CO2 supply line. In the event of a power failure or the instrument is turned off, the supply valve automatically closes. Additionally, when the A5 is not actively pumping, the supply valve is also closed. The presence of the supply valve prevents continual and unintended flow from the supply source.

Pump and fan index monitoring

The chiller circulatory pump, and the chiller fan all have active sensing to ensure proper operation. Should the circulatory pump or fan begin running at an excessively slow speed, or stop operating at all, the system will enter a not ready state and indicate the source of the fault.

Booster Motor and Injection Wash motor index monitoring

Any time the booster motor or injection wash motor are supposed to be operating, their motions are monitored. Should either of these motors report excessive motion signals, a torque fault is signaled. These signals generally represent an unexpectedly high pressure in the pump's fluidic paths prevent proper operation. The torque fault places the system in a not ready state and will be automatically cleared if normal operation is restored.

A power on check is also performed to ensure that the sensors and motor drive mechanics are operational. If during the power on check the motor(s) fail to advance, or the sensor fails to record motor motion, a system fault will be signaled.

Back Pressure Regulator Drive Home Sense

The back pressure regulator drive mechanics have an active home position sensor. At power on, or when the system begins operation after being in the OFF state, the BPR drive is exercised to move to a fully open (no pressure) position before moving into an operational range. This movement ensures the proper operation of the back pressure regulator drive mechanics.

CPU Watchdog timer

The processor implements a Watchdog timer. Should events occur in processor firmware that prevent proper operation and control of A5 hardware, the processor will automatically reset, disable active control, and execute power on diagnostics.

System Pressure monitoring

The Fusion A5 has pressure sensors that continually monitor system operation. These sensors perform general status, over-pressure, and under-pressure (leak/rupture) sensing.

CO2 Supply Pressure

A pressure sensor exists on the CO2 supply line. This sensor monitors the pressure of the incoming CO2 stream. In the event that this sensor drops below a low pressure limit value for a continuous minute, the system enters a Low Supply Pressure fault. This fault is self clearing on restoration of supply pressure.

Booster Pressure

A pressure sensor monitors the output of the CO2 booster. This sensor will scram the system (all zones off) should the pressure ever record a value in excess of an over pressure limit of 450 bar.

There is also under pressure sensing enabled. Should booster pressure drop noticeably below CO2 supply pressure for two continuous minutes, a leak will be assumed and the system will immediately shut down all zones.

In addition to the extreme over pressure event, a lower, configurable zone pressure limit is implemented. Should the booster pressure reach this configurable limit, the booster zone is immediately stopped until the zone reaches a normal operating range.

BPR Pressure

The back pressure regulator performs checks similar to the booster. Any recorded pressure value in excess of an over pressure limit of 450 bar will result in an immediate system shutdown.

Should there be five continuous minutes of readings noticeably below that of CO2 supply pressure; a leak will be assumed triggering an immediate system shutdown.

The back pressure regulator also implements a configurable zone limit. Should system back pressure reach this zone limit, the nozzle is commanded to open until the zone is within a normal range.

Aux Pressure

When equipped with an Auxiliary pressure sensor, the Fusion A5 will perform an immediate shutdown on pressure over 450b. This sensor is a witness to the HPLC column head pressure when installed.

System Temperature Monitoring

The A5 monitors and controls the temperature of the chiller and back pressure regulators. Temperature limits are imposed on these zones. Should the temperature exceed a configurable limit, the zone is turned off.

In addition to monitoring temperature, the temperature sensors are monitored for correct functioning and presence. Should a temperature sensor fail, or be removed from the system, the fault will be recognized and the zone will be shut down.

Inactivity Timeouts

The Fusion A5 has a standby mode whereby the chiller and nozzle temperature zones, and back pressure drive remain enabled. This mode has a duration limit that after four hours of standby operation, the A5 will shut down all control and enter the Off state.

Readiness timeout

The Fusion A5 monitors overall system readiness. Should the A5 operate in a not ready state for more than 15 minutes, it will be assumed that a fundamental error in system operation has occurred and the system will shutdown all control immediately. In normal operation, the A5 will achieve readiness within this timeout.

Power Supply Monitoring

The A5 continuously monitors internal power supply voltages for proper operation. Should a power supply exhibit an improper value, the system will enter a not ready state until such time that normal operation is restored.

System Logbook

All of the events, errors, and faults listed in this section are maintained in a hardware based logbook for the duration of the instrument power on state. These faults and error conditions can be read by the Aurora Diagnostic and Maintenance Utility.

Chapter 2

Site Requirements and Specifications

Physical and Facility Requirements

Overview

Selection of a site for installing the SFC Fusion A5 module is critical to achieving optimum performance, robustness and serviceability of the instrument. The A5 module is intended for use in a climate controlled industrial laboratory with adequate power, ventilation, CO₂ supply and mechanical integrity to support the units operation. The A5 module uses pressurized carbon dioxide (CO₂) as its primary fluid. Different laboratory sites have different requirements for use of liquefied gas cylinders or supply systems, and consideration must be made for safe routing and delivery of CO₂ vapor or liquid to the instrument.

The A5 module is an add-on accessory to an existing Agilent 1100 or 1200 series HPLC system operating under local ChemStation control. As such, the module must be located immediately adjacent to the HPLC stack. The A5 instrument design permits facile installation on either side of the instrument stack with only a few inches of total clearance on either side.

In general, meeting the following criteria for site selection will minimize installation time and optimize system performance:

- A permanently anchored, low vibration laboratory bench surface with adequate linear space and support capacity to handle the weight of the A5 module, HPLC system and PC controller
- A complete Agilent modular HPLC system stack including all original instrument covers and flow components.
- Sufficient permanent electrical outlets to handle all power cords of the system without use of temporary power strips or extension cords
- Nearby local fume venting access without routing across aisle ways or above ceiling tiles
- Nearby access to a CO₂ supply without routing across trafficked areas. If high pressure cylinders are used, adequate mounting hardware for securing tanks is required.
- A location away from direct exposure to sunlight and to variable temperature drafts arising from HVAC or adjacent instrumentation exhaust flows.

- Temporary access to the rear of the module and HPLC stack for component installation and cable routing.
- Typical laboratory level of air exchange rates of at least 6-10 per hour or higher [compared to typical office exchange rates of 4/hour].
- Low dust levels in air and on bench surfaces.

Customer Responsibilities

Make sure your site meets the specifications described in this chapter. Customers are responsible for providing the necessary space, venting capacity, electric outlets, gases, operating supplies, consumables and other usage dependent items such as columns, vials, syringes and solvents (minimum solvent purity: HPLC Grade Methanol, or Ethanol) required for the successful installation of instruments and systems.

In addition, customers are responsible for all tubing and fittings required for complete plumbing of the HPLC system from the binary pump inlet to the detector outlet. It is a good idea to keep extra tubing on hand for the installation of the A5 system, since new flow paths are used in the column compartment.

Tubing used in SFC should never be hand cut with a manual or an abrasive wheel cutter. Such cuts tend to be irregular and provide poor low dead volume connections. SFC mobile phases have very high diffusion rates and tubing of greater than 0.007” id is inappropriate. Tubing id of 0.005” is preferred in the SFC flow system.

Agilent sells very flexible stainless steel capillary tubing terminated with 1/16” OD caps for high pressure fluidic connections in a variety of lengths. These tubes use Swagelok™ style compression fittings and are preferred for SFC use. The tubing is color coded. Red indicates 0.005” id and green indicates 0.007” id.

Use of PEEK tubing or ferrules is not recommended. Extreme care must be taken when loosening such polymeric fittings since the tubing can blow out resulting in rapid release cryogenic CO₂ and solvent if the system is pressurized.

WARNING Use of PEEK tubing or ferrules is not recommended. Use of polymeric ferrules can allow tubes to “blow out” spontaneously during operation or when loosened under pressure.

Further, the customer is responsible for the operating condition of the HPLC system at the time of installation. If modules have been modified from their initial condition [for example, mixing components removed from the binary pump, the components should be restored. It is strongly recommended that prior to installation of the A5 module, the HPLC system receive a professional service examination which tests operational qualification and performance verification for each individual module and the system. Such testing, however, does not always reveal issues such as contamination or minor

leaks that can plague the performance of SFC if not addressed. The user should also provide a complete rinsing of untested elements such as the vacuum degasser.

Finally, in locations outside the United States, customers are responsible for supplying a suitable power cord in conformance with local regulations. The A5 power cord specification is found in the Electrical section of the chapter.

NOTICE

If you have problems in providing anything described as a Customer Responsibility, please contact your local Aurora SFC Systems agent for discussion and for assistance.

Ventilation.

The SFC Fusion A5's exhaust must be vented outside of the laboratory environment. This can be done by placing the outlet of the waste bottle into the air stream inside a chemical fume hood or into a sealed local vent access to the outside. The exhaust vent system should not be part of an environmental control system that recirculates air inside of a building. Exhaust venting requirements need to comply with all local, state and federal environmental and safety codes.

Venting Capacity: Not less than 0.5 cuft/minute (14 liters/min).

A 2 meter (6ft.) length of 1/4 inch i.d., 1/2 o.d. tygon tubing is included for venting the gaseous exhaust. A small plastic bottle is provided to separate liquid components from gaseous exhaust. The vent line may be easily extended by a 1/2" o.d. Teflon or tygon extension tube. The customer is responsible for collection and disposal of all waste streams and maintenance of the waste collection system.

The waste stream from a supercritical fluid chromatograph consists of liquid droplets entrained in a high velocity gas. The liquid is easily trapped in any suitable container but the gas stream **MUST** be vented into a fume hood or through a vent to the outside. A tube from the outlet of the back pressure regulator can be directed into the supplied waste bottle to capture the liquid.

A small amount of modifier is always present in the gas stream. In the case of methanol, between 1 and 2% methanol is always present in the waste gas at room temperature. Methanol is toxic and prolonged exposure may lead to serious health issues. Consult the Materials Safety Data Sheet shipped with the solvent for appropriate handling, storage and use.

WARNING

The effluent from a supercritical fluid chromatograph may contain vaporized, toxic solvents. Never vent into an enclosed, occupied space. Always vent into a fume hood or vent to the outside.

Many of the modifiers used in SFC are toxic and semi-volatile. They should only be used in a space designed as a chemistry laboratory or other suitable space with a high rate of air exchange.

In addition to exhaust ventilation, the A5 unit should only be operated in an area with sufficient laboratory air exchange, generally 6-10 air exchanges per hour. During routine operation of the A5 module small volumes of CO₂ are released the air from low level leaks, column changing, exchanging the CO₂ supply tank etc. With proper air exchange levels, these releases are not be considered hazardous since they do not approach the OSHA personal exposure level (PEL) for 8-hour exposure for CO₂.

As an added safety step, the local air in the vicinity of the A5 system can be monitored for CO₂ via any of several inexpensive air quality monitors. Alarm levels should generally be set to 5000 ppm, the OSHA 8-hour PEL. If the alarm sounds, action should be taken to identify the specific CO₂ leak source. It should be noted the exhaling directly on to such a CO₂ monitor will drive it to an alarm state since the CO₂ content of expired air exceeds the PEL level.

Environmental Conditions

The SFC Fusion A5 is a laboratory instrument and not suited to use outdoors or in areas with uncontrolled temperature and humidity conditions. Environmental requirements for temperature, pressure and humidity for the SFC Fusion A5 system are generally more restrictive than those of many high performance HPLC systems intended for laboratory use. Operating the SFC Fusion A5 System within the recommended temperature ranges insures optimum instrument performance and lifetime. Performance can be affected by sources of heat and cold from direct sunlight, heating, air conditioning systems, or drafts as mentioned earlier.

The site's ambient temperature conditions must be stable for optimum performance of the entire system. Temperature changes of 3°C / hour or less (as defined by ASTM conditions) are required to achieve best possible baseline stability. Higher variations will result in higher signal drift and wander of the baseline of the coupled HPLC system.

Allowed temperature and humidity ranges:

- operating temperature: 15 to 30°C (59 to 85°F),
< 3°C/hour rate of change
- operating humidity < 95%, non-condensing
- operating Altitude: up to 2000m (6500ft).

There is a small dependency between room temperature and the flow rate of carbon dioxide delivered by the SFC. The density of the fluid delivered depends on the temperature of the Agilent binary pump head, which is not controlled. If the instrument experiences large day to day swings in temperature, flow may vary by more than 1%.

The SFC Fusion A5 and HPLC instrument should be situated to avoid intermittent, direct, strong air drafts, such as emanating from heating/cooling equipment. This is particularly true when attempting to perform trace analysis. The refractive index of carbon dioxide varies 30 times more than the refractive index of water in the vicinity of room temperature. The largest single source of UV detector noise can be drafts from air conditioning/heating ducts. Avoid direct sunlight which can cause uneven heating.

The SFC Fusion A5 is unique in being able to pump carbon dioxide that is supercritical (>31°C) in the source. However, excessive heat places higher demands on the chiller/condenser. Further, this temperature region is subject to high rates of change in CO₂ density. These factors drive the specification that laboratory air temperature should be maintained below 30°C.

Finally, care should be taken when arranging instrument configurations in a back-to-back orientation so that hot exhaust of one instrument is not exposed to the air intake of the other. The A5 module intakes cooling air near the bottom rear of the instrument and exhausts air near the top of the rear enclosure panel. A5 exhaust air is never more than a few degrees above room temperature. However, large instruments, such as mass spectrometers can deliver large volumes of heated exhaust. Such exhaust should be deflected upward and away from the A5 module rear panel.

Although The SFC Fusion A5 has minimal problem with condensation on cold surfaces, any condensation should be avoided. There is a “leak” tray with a leak sensor at the bottom of the A5 module to catch any condensation or leaks and divert them to a waste bottle. However, any significant volume of liquid in the leak tray will trigger the leak sensor and shut off the pump.

<p>CAUTION Do not store, ship or use your The SFC Fusion A5 module under conditions where temperature fluctuations could cause condensation within the module. Condensation will damage the system electronics. If your module has been shipped in cold weather, leave it in its box and allow it to warm up to room temperature slowly to avoid condensation.</p>

Bench Space

The A5 Module requires approximately 1 foot of linear bench space immediately adjacent to the target HPLC system stack. Approximately 5 inches of free space is required behind the instrument for cable access and adequate air flow for ventilation. Similar access to the rear of the HPLC stack is also required to install cables and interface cards. As mentioned earlier, for optimal performance, the rear air space should not be heated significantly from room temperature by the exhaust of other instrumentation in the lab, rather hot exhaust should be vented or directed upward from the instrument.

The module is designed to install on either side of the HPLC stack with sufficient high pressure transfer tubing to attach to a double stacked system. In the event the LC is attached to a split flow detector such as Mass Spec or ELSD, the A5 module should be positioned on the opposite side of the stack. Shelves overhanging the A5 module should provide a minimum of 6 inches of clearance to allow access to the rear power switch. Finally, the PC system interface to the A5 module is USB 2.0. A six foot cable is supplied with the system. The CPU must be placed within range of this cable. Alternately the user may supply an extended length USB cable not to exceed 16 feet.

While the SFC Fusion A5 module can exist on either side of the HPLC, it is often easier to locate it on the left side of the HPLC system.

Dimensions and Weight

Select the laboratory bench space before your system arrives. Pay special attention to the total height requirements. Avoid bench space with overhanging shelves. Pay special attention to the total weight of the modules and solvents you have in addition to the SFC Fusion A5. Make sure that your laboratory bench can support this weight.

Table 2.1
Nominal Weight and Dimensions for the
SFC Fusion A5 Module

Weight	26 kg	56 lbs.
Height	60 cm	23 in
Width	26 cm	10 in
Depth	48 cm	18 in

Fusion module is heavy (approximately 26KG or 56 pounds). The module should be removed from its packaging and lifted to the bench by two people. It should be positioned on a sturdy bench capable of holding this weight plus the weight of the HPLC system with which it is operated.

WARNING	The SFC Fusion A5 module is heavy. The module should be removed from its packaging and lifted to the bench by two people.
----------------	---

A dedicated 15 Amp 100-120V or 10 Amp 200-240V [+/- 10%] AC power outlet with line frequency of 50-60 Hz [+/- 5%] is required for the SFC Fusion A5. The A5 module should be located within 1 meter (3 feet) of this outlet. In addition, the host HPLC system, computer system and printer require additional outlets.

In locations outside of the US, the customer is responsible for providing an IEC 60320 C13 power cord to connect to the IEC 60320 C14 panel connector located on the rear of the SFC Fusion A5.

Power specification for the SFC Fusion A5 is 100-240 VAC 50/60 Hz 700 VA Max.

Gas Supply Selection

The A5 module can accept either liquid or vapor phase CO₂ at its inlet. Both phases must be clean and substantially free of other entrained liquids, vapors or solids. It is highly recommended that CO₂ delivered from high pressure cylinders be delivered as vapor [i.e. no dip tube]. The A5 module contains a CO₂ supply valve that will fail if inlet pressure exceeds 1200 psi. As a result, large CO₂ supply systems may require pressure regulation to prevent overpressure. The maximum recommended inlet pressure is 1000 psi. The minimum inlet pressure is 600 psi [40 bar]. A listing of suitable and unsuitable CO₂ supplies appears below.

Suitable CO₂ Supplies

- Beverage Grade CO₂ (>99.98% bulk purity) delivered as a vapor from high pressure cylinders
- SFC Grade CO₂ (>99.9999% bulk purity) delivered as a vapor or liquid from high pressure aluminum cylinders.
- High purity CO₂ (>99.9998% bulk purity) delivered from a distributed high capacity CO₂ delivery system. The CO₂ may be delivered as either a vapor or liquid. The user is responsible for providing lubricant-free shutoff valving to isolate the A5 module from the supply system. Also adequate pressure regulation must be supplied to prevent exceeding the maximum inlet pressure specification

Unsuitable CO₂ sources include:

- Cryogenic Dewar Cylinders or tanks. The vapor from these vessels is of insufficient pressure.
- Helium padded high pressure CO₂ cylinders
- premixed CO₂/organic liquid cylinders

Aurora provides a CGA 320 gas connection as part of US ship kits. Outside of the US, the customer must provide a means of interfacing a supplied 1/8" steel tube with (Swagelok type) compression fitting to the gas supply or bottle. A 6-foot [~2meter] 1/8"od inlet transfer line is included with the system. The user supplied CO₂ system must be located within range of this line. Alternately, the line may be extended by the user using appropriate compression fittings, and pressure rated stainless steel transfer tubing.

Conversions: 1 psi = 6.8947 kPa = 0.068947 Bar = 0.068 ATM

Cylinder Storage.

Carbon dioxide in steel cylinders exists as a liquid in contact with a vapor. Direct storage in the hot sun, or other hot locations can result in vaporizing ALL the fluid, generating excessive pressure which could rupture the safety disk, located in the cylinder valve. Consult the cylinder supply company for appropriate storage conditions.

Carbon dioxide in cylinders should not be stored in extremely cold locations, either. Storage at very cold temperatures results in a significant drop in cylinder pressure, which prevents a pump at higher temperatures from pumping the fluid inside. Although there is no safety issue with cold locations, carbon dioxide is a very poor conductor of heat, and it may take many hours, or even days to warm. The carbon dioxide cylinder pressure must be above 600 psi to satisfy inlet pressure requirements of the A5.

Flammable Solvents

The A5 module is exposed to solvent contact from two sources: the return line to the BPR and the wash pump. Some solvents are flammable and must always be handled with appropriate care. In normal operation, solvents are channeled out of the A5 unit to proper waste receptacles; however, accidental leaks within the system are possible. With all covers in place, leaks are channeled to eventually reach the bottom drip tray where a leak sensor will halt operation of the system.

The table below lists several common laboratory solvents with varying autoignition temperatures. The normal maximum operating temperature of the BPR is limited to 70 C with a power off fail safe maximum of 100 C. In a runaway condition, temperatures may reach significantly higher temperature. Solvents with autoignition temperatures below 200 C must not be used. This includes such solvents as carbon disulfide and diethyl ether and some hydrocarbon mixtures. Further, solvents with flash points less than 0 C are strongly discouraged from use. If these solvents are used, the operator takes responsibility for providing extended safety procedures to maintain safe operation.

<p>Warning Carbon Disulfide and Diethyl Ether are prohibited for use in the A5 module. These materials have unusually low autoignition temperatures and can form explosive byproducts such as peroxides. These and similar reagents represent a severe fire or explosion hazard.</p>

When flammable solvents are used with the A5 unit, the unit should be located away from open flames and spark sources.

Table 2.2 Flammability Parameters of Common Laboratory Solvents

Solvent	Closed Cup Flash Point (°C)	Lower Explosive Limit %v/v	Upper Explosive Limit %v/v	Autoignition Temperature (°C)
Carbon Disulfide	-30	1.3	50	90
Diethyl Ether	-45	1.9	36	160
Pentane	-49	1.5	7.8	285
n-Hexane	-22	1.2	7.5	233
Acetone	-18	2.6	12.8	485
Methyl Ethyl Ketone	-7	1.8	11.5	505
Ethyl Acetate	-4	2.2	11.4	460
n-Heptane	-4	1.2	6.7	215
Nonaromatic Hydrocarbon Solvent (100- 140 C boiling range)	1	0.8	8	275
Toluene	4	1.3	7	535
Methanol	10	7.3	36	455
Isopropanol	12	2	12	425
Ethanol	13	3.3	19	365
n-Butyl Acetate	24	1.7	15	370
m-Xylene	25	1.1	7	525
n-Butanol	35	1.4	11.2	340
Mineral Spirits (150-200 C boiling Range)	38-43	0.7	6.5	258
Nonaromatic Hydrocarbon Solvent (150- 200 C boiling range)	39-43	0.6	6.5	260
Aromatic Solvent (150- 200 C boiling range)	47-50	1	7.5	496
Nonaromatic Hydrocarbon Solvent (200-230 C boiling range)	82	0.6	5	250
Nonaromatic Hydrocarbon Solvent (250-270 C boiling range)	117	0.5	4.7	240

HPLC Requirements

The SFC Fusion A5 interfaces to a pre-installed and fully functional Agilent 1100/1200 HPLC system. Prior to installation of the A5 module, the customer is responsible for insuring the HPLC system performs to the manufacturers operating specifications. A preferred order of components for low noise operation from top to bottom is:

- solvent storage compartment
- vacuum degasser module
- binary pump module
- Autosampler module
- Column oven module
- Detector module

The system should be fully rinsed to remove residual organics, buffers and incompatible solvents. Aurora recommends rinsing Channel A with 100 mL of HPLC grade water followed by 100 mL HPLC grade methanol. Channel B including the degasser channel be rinsed with 100 ml of water followed by 100 mL of methanol. Allow the rinse solvent to flow through the entire system [replace the column with a union]. After rinsing, drain solvent from the channel A ports [A1 and A2 if a selection valve is used] and plug the degasser ports for these channels.

If pump seals have been in service more than three months, Aurora recommends that they be replaced using the yellow [UHMW PE blend] seals available from Agilent[p/n 0905-1420 for normal phase solvents] or Aurora SFC Systems [p/n 00-73-1010]. A set of seals is supplied with the A5 ship kit. The installed black Agilent seals [p/n 5063-6589] will work but will have a shorter service life pumping CO₂.

As part of the sales process, the customer will be asked to complete a configuration description of the host HPLC system using the Aurora SFC Systems Configuration Guide. Please refer to this guide for detailed instructions, compatibility requirements and ordering specifics.

In brief:

- All model numbers refer to both 1100 and 1200 series Agilent modules with any letter designation [A,B, etc.] unless explicitly stated
- The HPLC system must utilize a G1312 Binary Pump to provide high pressure mixing. A required Binary pump compatibility kit is included as part of the A5 System. Agilent Isocratic and quaternary pumps are not supported at this time.
- Agilent autosamplers such as the G1313, G1329, and G1367 are acceptable with installation of a required AutoSampler compatibility kit available from Aurora SFC Systems. CTC Pal autosamplers are acceptable with a separate kit.

- UV detectors such as a VWD, DAD, or MWD are acceptable when utilizing a high pressure flow cell. Such cells may be available from Aurora SFC Systems or other vendors. In the case of the 1100 DAD and MWD modules, B series or higher are recommended. Please consult your sales representative for specifics.
- All modules should be upgraded to firmware Rev A.06.01 or greater.

NOTICE

Anecdotally, some older versions of the 1100 series modules have demonstrated problems with certain revisions of the A.06.0x firmware. A specific pattern has not been identified. If the module behaves abnormally with later firmware versions in this series, try an earlier version. As a last resort, back the firmware rev to the last A.05.xx version. This will require downgrading all modules in the stack since communication issues exist in the CAN bus between revs A.05 and A.06. Use of rev A.05.xx firmware will prevent mixed use with 1200 modules in the stack.

The Customer must insure that any other additional modules, detectors, valves, columns, tubing, fittings, etc are compatible with pressures, temperatures, and solvents used in the SFC system.

PC and Software Requirements

The HPLC system must be installed and controlled with Agilent ChemStation versions B.02.01 or newer. Older versions are not supported.

The PC should not have power save/power down modes enabled. Windows XP [w/ SP2 or SP3] and Vista w/ SP1 are supported. Windows 2000 w/ SP4 will function but is not recommended due to poor performance of the USB communications port. Installation of current service packs and updates for the operating system and system utilities is recommended. Anti-Virus software is recommended, but full disc scans should not be performed during instrument operation.

The PC must have an available USB2.0 port. Available memory must meet the HPLC manufacturer's requirement for the installed workstation. Aurora recommends a minimum of 2 Gbyte of installed memory.

Summary of SFC Fusion A5 Specifications

Table 2.3
SFC Fusion A5 Specifications

Physical

Weight	26 kg
Dimensions (h × w × d)	60 × 26 × 48 cm
Line voltage	100 – 240 VAC
Line frequency	50 or 60 Hz
Power consumption	700 VA Max
Operating temperature	15-30 °C
Non-operating temperature	-40 – 70 °C
Humidity	< 95 %, Non-condensing
Laboratory Ventilation	minimum 6 air exchanges/hr for lab air; CO2 monitor recommended w/ alarm @5000 ppm
Exhaust Vent capacity	>20 liters/min with sustained negative pressure
Operating Altitude	up to 2000 m (6500 ft)
Non-operating altitude	up to 4600 m (14950 ft)
Safety standards:	IEC, NRTL

Chemical

Inlet CO2 Bulk Purity	>99.99% vapor; >99.999% liquid
Inlet CO2 Phase	vapor from non-diptube high pressure cylinder; liquid from commercial CO2 delivery system
Inlet CO2 Supply Pressure	40 - 70 bar [580 to 1000 psi]
Inlet CO2 temperature	10 - 30 C
Wash Solvent	HPLC grade alcohol
Liquid Coolant	30% propylene glycol in deionized water; proprietary antioxidants; red dye added for safety
Coolant volume	< 300 mL

Wetted Materials

High Pressure flow path	300 and 400 series stainless steel PEEK, Carbon filled PEEK Teflon, PTFE, FEP, CTFE UHMW PE Ruby, sapphire, ceramic
Low Pressure flow paths [Waste; Wash Pump; Leak Tray]	316 Stainless steel PEEK Teflon, PTFE, FEP, CTFE CPE; LDPE Tygon PVC
Vapor Exhaust	Tygon PVC

Performance

Hydraulic system	Single piston with proprietary motor control
Total Hydraulic Volume	< 5 mL @ pressure < 70 bar < 25 mL @ pressure up to 400 bar
Chiller system	Thermoelectric cooling with secondary air/liquid cooling circuit
Back Pressure Regulation (BPR) System	Low volume diaphragm type with proprietary drive control; replaceable BPR head assy; No required recalibration after head replacement
Chiller temperature	- 20 to 9 C variable with flow and pressure demand
Booster Pump Speed range	0 - 6000 steps/sec average step rate
Booster Pump Pressure range	100 - 400 bar up to 5 ml/min demand
Pressure pulsation	< 2 % amplitude at pump speed > 300 st/sec and outlet pressure >100 bar
BPR Thermal range	40 -70 °C (104 - 158 F)
BPR Thermal precision	± 1 °C
BPR Pressure range	100 - 400 bar
BPR Pressure accuracy	Better than 2% after calibration to host Pump
BPR Pressure precision	Better than ±0.5 bar [±0.2 bar typical] measured downstream of separation column
Control and data evaluation	Agilent ChemStation for LC with SFC Fusion A5 driver; Aurora A5 Diagnostic Program
Analog in pressure monitoring	1 V FS; one input; range set by calibration to host pump
Communications	USB 2.0; APG Remote: ready, start, stop and shut-down signals; relay contact closure [wash pump only]

Chapter 3

Installing the SFC Fusion A5

Hardware Installation

General Procedures

Proper use of wrenches

Some of the plumbing connections require a nut to be tightened onto a fitting. There are often two sets of “flats” next to each other. Attempting to tighten the nut without securing the other part of the fitting with a second wrench can result in loosening yet another connection upstream or downstream. It is “best practice” to always hold the fitting with one wrench while tightening or loosening another connection.

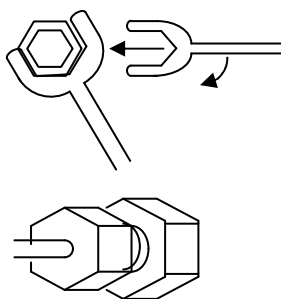

Figure 3.1
Proper tightening of Fittings

Compression (Swaged Fittings)

Most of the fittings in the Fusion and Agilent modules are either Swagelok or Valco. Use the appropriate fitting as recommended by the equipment manufacturer. The recommended tightening procedure to install new fittings is to tighten the nut finger tight then turn an additional $\frac{1}{4}$ to $\frac{1}{2}$ turn to seal. In general, previously swaged fittings need only an additional $\frac{1}{8}$ th turn once finger tight.

In SFC, the fluid has $\frac{1}{10}$ th the viscosity of water, so this may not be tight enough. All connections should be checked for leaks and tightened further if necessary. Soapy water or “Snoop” make it easy to find leaks if carbon dioxide is in the fluid. Tiny bubbles appear in the liquid around the fitting.

Each fitting should be individually and carefully installed. The depth of the tube inside the fitting is very important. If the tube pilot (length beyond ferrule end) is too long, the fitting can leak or with excessive tightening permanently bind. If the pilot is too short, a poorly swept volume and be created. This poorly swept volume will create noticeable chromatographic tailing. If the pilot is way too short, the fitting could fail under use. Pilot depths are not always interchangeable between fittings. It is a best practice to swage a tube in the fitting that it will be used in. It is best to provide some light force to hold the tube in the fitting and preventing the tube from exiting while tightening the fitting.

Excessive force can actually result in breaking off some components and obviously should be avoided. It may be more expedient to replace the whole fitting if one of the connections fails to seal. You may notice that some of the more expensive components (such as a pressure transducer have a less expensive fitting mounted to them to act as a sacrificial fitting. Connections should be made to the less expensive component, and repetitive removal and replacement to one of the more expensive fittings should be avoided.

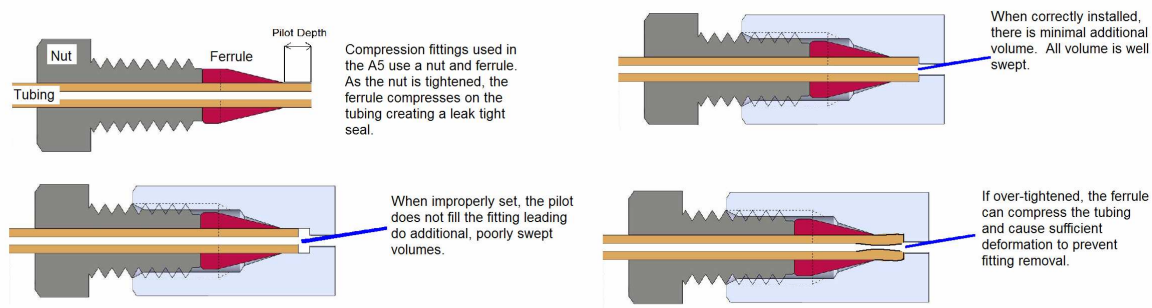

Figure 3.2
Compression fittings

Preparing the HPLC

Fusion is not a “magic bullet” that can convert a broken or non-compliant HPLC into an excellent SFC. The HPLC to be converted to an SFC must be in proper working order as an HPLC. The system needs to pass normal HPLC acceptance criteria.

If the instrument is an older unit, please ensure all the covers are available, and fit, and the plumbing matches the manufacturer’s recommendations. Detector lamps should be evaluated using the manufacturer’s procedure to determine whether they need to be replaced. If the user decides to have a preventive maintenance performed prior to the installation of the Aurora fusion Module, the main pump seals for the A side of the binary pump should be compatible with normal phase operation. Operating the pump with the

standard reversed phase seals will result in a shorter seal life than would otherwise be expected.

Salts and Water - Flushing the Instrument

Many inorganic salts are not soluble in carbon dioxide and need to be removed from the pump before conversion to an SFC. SFC mobile phases can actually tolerate small amounts of water. In fact water is sometimes added to the methanol or ethanol to help solubilize very polar amphoteric compounds.

If the HPLC is checked out as a reversed phase HPLC, it needs to be flushed in a specific manner to remove salts and water. Remove the column and replace with a union. This involves pumping pure water without salts for at least 30 minutes at 5 ml/min. The entire system, including pump, autosampler, oven and detector need to be flushed. After flushing salts, the pure water should be replaced with pure methanol (or ethanol, or isopropanol) for at least 30 minutes at 5ml/min. After this flush the instrument is ready for conversion to an SFC.

Preferred Stack Arrangement

In order to minimize delays and broadening caused by excessive tube lengths, we recommend the following stack layout. The SFC Fusion™ A5 needs to be immediately adjacent to the LC stack, but can be placed on either side. In the preferred arrangement, the degasser and solvent tray are located on the top of the stack. These feed into the binary pump, and the A5 injection wash pump. Underneath the degasser is the Binary pump. The binary pump is located directly above the autosampler. The autosampler is above the oven, which is above the detector.

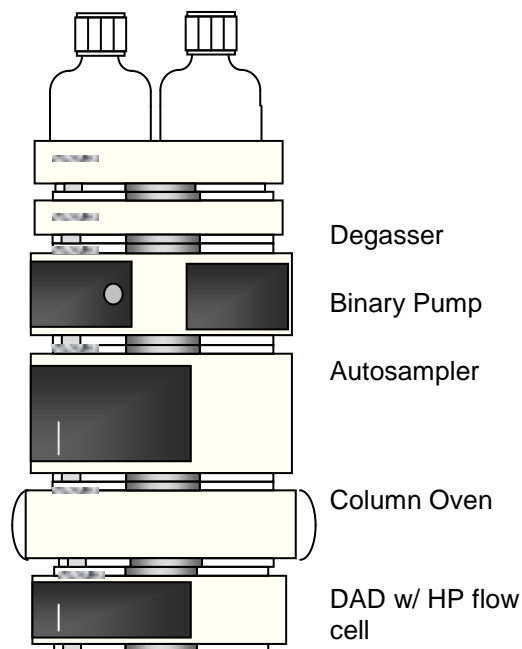

Figure 3.3
Preferred order of Agilent HPLC Components

It is recommended to plumb the system with small diameter tubing. For general use 0.17mm or 0.007” tubing should be used. In more demanding applications where pressure drops are not excessive, 0.12mm or 0.005” tubing can be selectively used. Use ferrules and tubing connections as recommended by the equipment manufacturer.

All four degasser channels will be available for solvent usage. It is highly recommended that one channel be reserved for neat methanol (no additives). Reserving this channel will minimize the time needed for flushing the degasser as solvents are changed. Failure to adequately flush the degasser when switching solvents will greatly impact sensitivity.

Modifications to the Agilent Binary Pump

Preparation

Binary Pump is installed in the LC system. Purge both A and B pumps with methanol to remove water and buffers from entire system.

Converting the Agilent Binary pump for SFC usage requires two modifications. The first modification is to replace the normal active inlet valve and outlet ball valve in the Channel A, left side pump with filtered high pressure capable check valves and check valve holders. The second modification is to add a purge valve and check valve inline with the Channel B, right side pump. This additional purge valve should be used preferentially for purging or priming the modifier (B) pump. If the original valve were to

be used, it would expel both modifier and CO2 flow streams. The new valve, isolated by the inline check valve, will only expel B side fluids.

After these modifications are complete, the Channel A pump will be used for delivering CO2 while the Channel B pump will be used for modifier delivery. If the binary pump is equipped with a solvent selection valve, neither of the A channels will be used.

It is highly recommended that the user familiarize themselves with standard maintenance functions and terminology used in the binary pump. This information is available in the Agilent Binary pump reference manual and user guide.

WARNING When opening capillary or tube fittings, solvents may leak out. Please observe appropriate safety procedures (for example, goggles, safety gloves and protective clothing) as described in the material handling and safety data sheet supplied by the solvent vendor, especially when toxic or hazardous solvents are used.

Parts Required

Flat metric wrench used to remove the active inlet check valve, replacement passive inlet and outlet check valves, electronic jumper, and modifier purge valve assembly. Two ¼”-5/16” wrenches for capillary connections.

All of the parts required to adapt an Agilent Binary pump for use with the SFC Fusion™A5 are supplied with the A5 in the Binary Pump Compatibility Kit.

Table 3.1
Agilent Binary Pump Compatibility Kit

A5-69-4130	1	Agilent Binary Pump Compatibility Kit
A5-21-2010	1	Check Valve Holder Adapter (Agilent - Inlet)
00-73-2140	1	Check Valve Holder (Outlet - Agilent)
00-73-2010	2	Check Valve Cartridge; 0.125 ball
A5-60-2740	1	Lemo Adapter Cable Assembly
00-84-2020	1	BNC Cable
A5-69-4510	1	Modifier Purge Valve Assembly
A5-53-7990	1	Agilent Pump Compatibility Option Installation Guide
00-73-1020	2	Agilent Pump Seals

Additionally, you will need a 14mm (thin) wrench supplied by Agilent with the binary pump, and ¼”, 1/2”, 9/16”, and 5/8” wrenches.

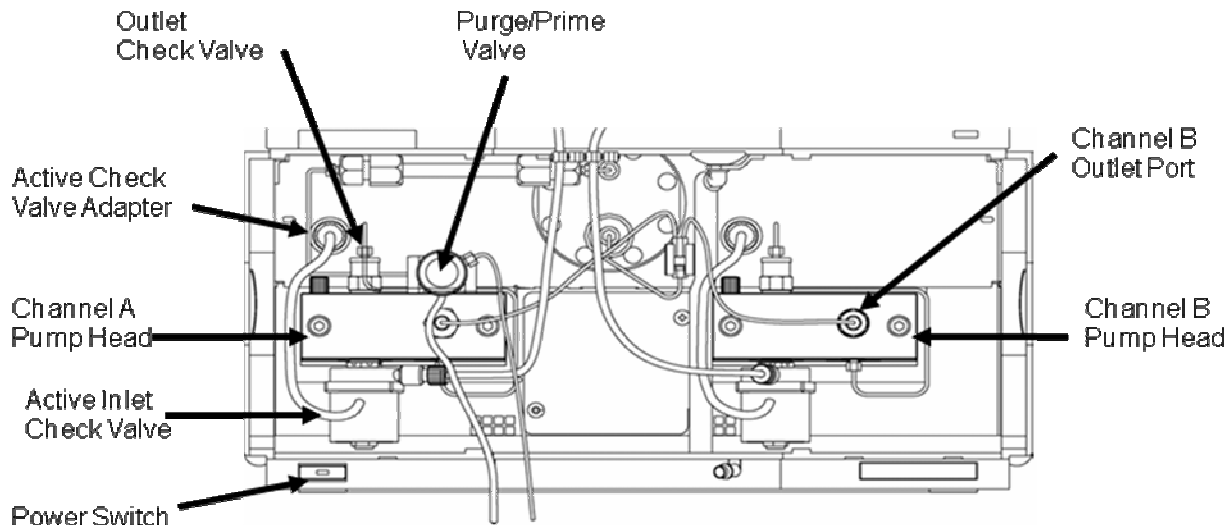

Figure 3.4
Diagram of the Agilent Binary Pump

WARNING

When opening capillary or tube fittings, solvents may leak out. Please observe appropriate safety procedures (for example, goggles, safety gloves and protective clothing) as described in the material handling and safety data sheet supplied by the solvent vendor, especially when toxic or hazardous solvents are used.

1. With the power off, and pump disconnected from its power source remove the front cover of the Agilent binary pump, by pressing the snap fasteners on both sides.
2. If equipped with a solvent selection valve, disconnect the 1/4-28 fittings from the A side of the selection valve to the left side active inlet valve. Plug **or remove** all A side connection to prevent siphoning.
3. Disconnect any tubing supplying liquid to the left hand (A) active inlet check valve, making sure to prevent siphoning.
4. Unplug (electrically) the left hand (A) active inlet check valve from the front panel of the pump.
5. Using the Agilent supplied 14mm flat wrench, carefully loosen and remove the active check valve being careful not to damage the gold seal on the mating surface. Store the active inlet check valve in a safe place for future use.
6. Replace the active inlet check valve with the passive inlet check valve holder and cartridges supplied with Fusion. Insure that the arrow on the check valve is pointing upward. Additionally, the check valve will have a

filter frit on the bottom and an open hole on the top. The threads on the new inlet check valve holder have a fine pitch. Carefully thread this fitting in by hand. This fitting should be able to easily turn with finger **force only many turns**. A wrench should only be used for final tightening. Tighten snugly without using excessive force.

7. The SFC Fusion™ A5 Booster will connect to this check valve inlet. This is the CO₂ (mobile phase) entry to the HPLC system.
8. Plug in the gray plastic LEMO adapter into the electrical connector previously used by the Active Inlet Valve.

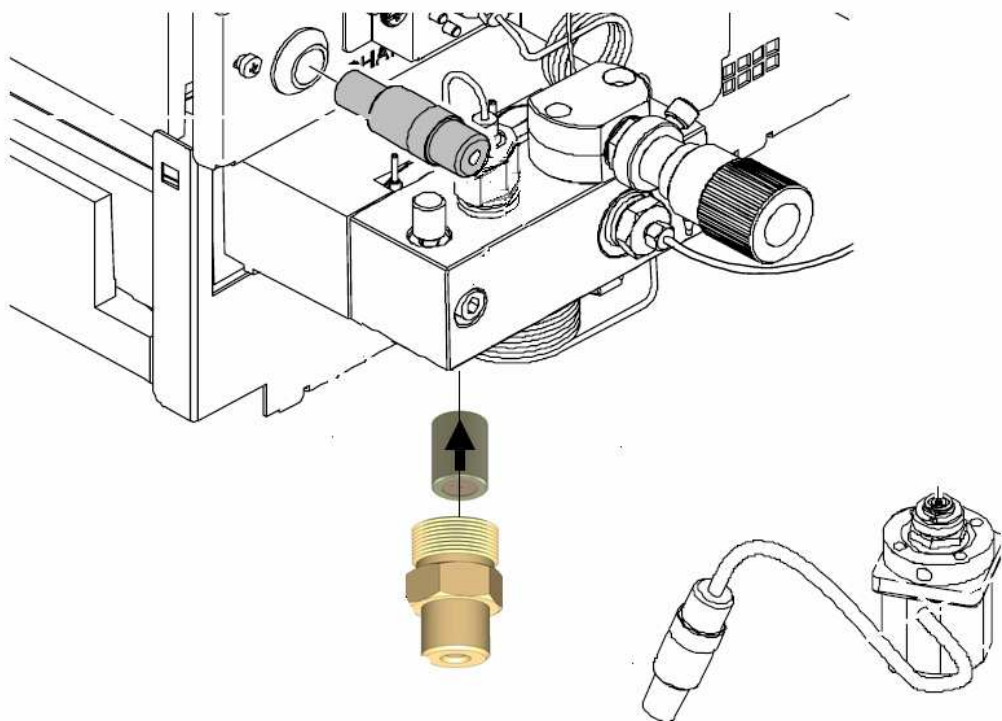

Figure 3.5
Installation of the Inlet Check Valve

1. Remove the tube from the absorber capillary that connects to the outlet ball valve. Do not damage this tube and fitting end, it will be reused in a subsequent step.
2. Remove the Agilent outlet check valve of the Channel A pump. Retain this for future use.
3. Install the new Aurora supplied Outlet check valve, and check valve holder in its place. Insure that the arrow on the check valve is pointing upward. Additionally, the check valve will have a filter frit on the bottom and an open hole on the top. Tighten snugly without using excessive force.

4. Reconnect the absorber capillary to the outlet check valve holder.

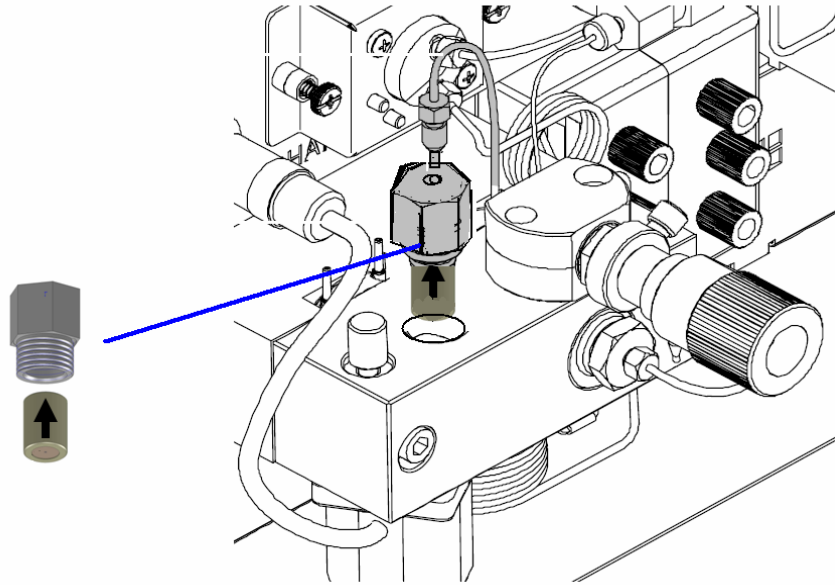

Figure 3.6
Installation of the Outlet Check Valve

5. Install the purge valve on the B pump. The knurled nut interfaces with a threaded hole on the top right face of the Channel B pump head.

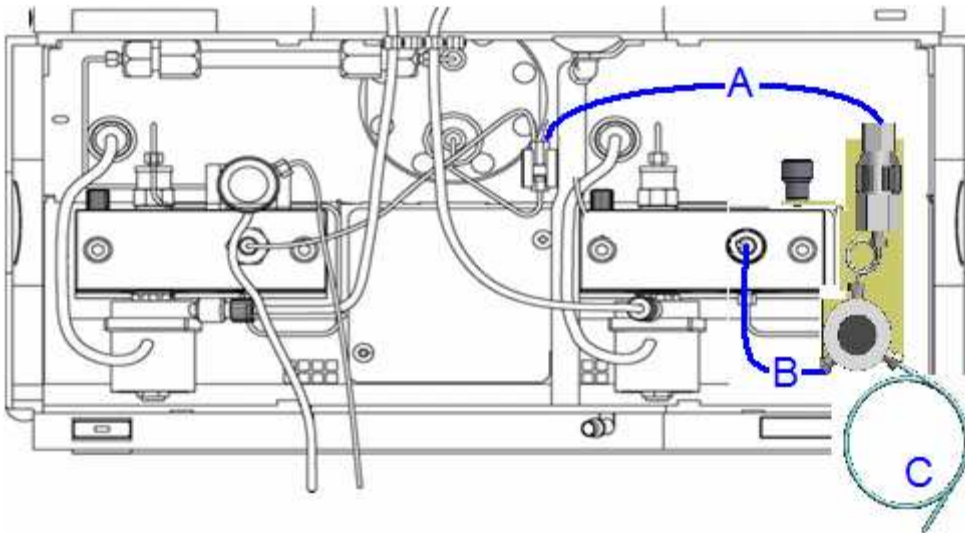

Figure 3.7 Installation of the Modifier Purge Valve

6. Remove the line (tee) from the Channel B outlet Port and re-install it in the outlet of the in-line check valve holder This is labeled as A in the diagram above.
7. Connect the inlet of the purge valve to the outlet of the pump (Channel B outlet Port) with the stainless steel tubing provided as part of the purge valve assembly. This is labeled as B in the above diagram.
8. Connect the Teflon outlet tube of the new purge valve assembly into the top cover of the SFC Fusion™ gas liquid separator (and waste bottle). This is labeled as C in the above diagram.
9. Connect the output of the SFC Fusion Booster to the inlet check valve holder of Channel A.
10. The BNC coaxial cable can be used to connect the Analog Output on the back panel of the Binary pump to the SFC Fusion A5 Reference In terminal/connector on the back of the Fusion module. Be aware that a similar appearing output exists on the DAD and VWD detectors that should NOT be utilized.

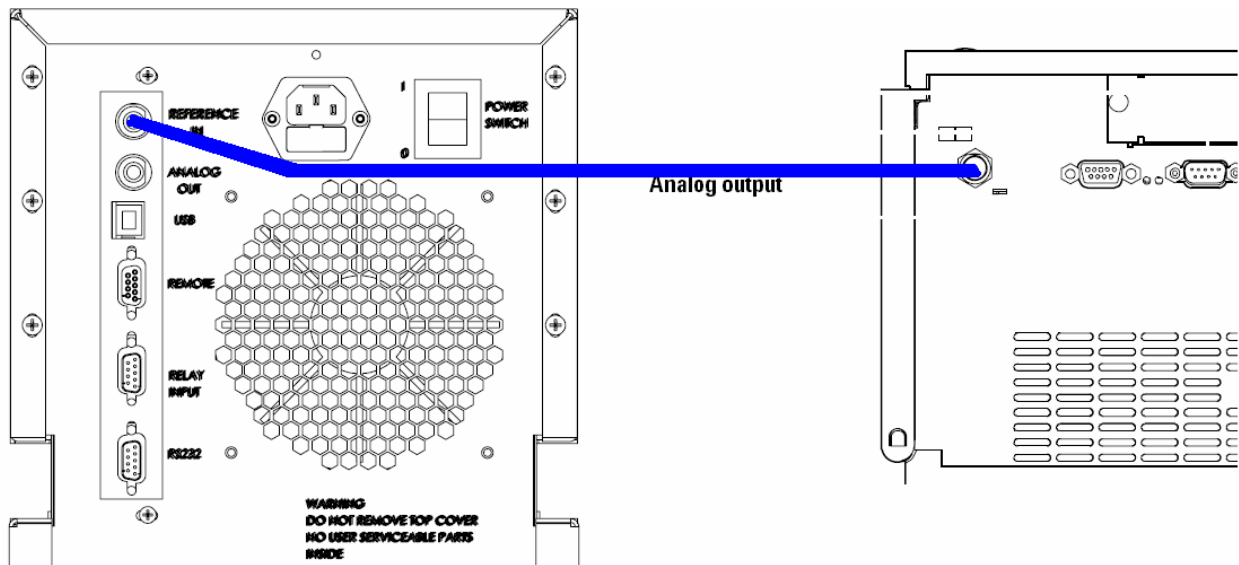

Figure 3.8 Connecting the Analog Reference Signal

Modifications to the Agilent Autosampler

Preparation

When the autosampler has previously been installed in an LC system, purge the system for at least 30 minutes with both water and then methanol to remove water and buffers from entire system.

Converting the Agilent Autosampler for SFC usage requires two modifications. The first modification is to replace the normal two groove rotor in the injection valve with a three groove rotor to allow the sampler to operate as a closed loop injector. The stator of the valve is re-plumbed, with the addition of an external sample loop, plus movement of the remaining fittings. The second modification is to add an accessory interface board to the ALS allowing it to communicate with the SFC Fusion™ A5 during and injection.

It is highly recommended that the user familiarize themselves with standard maintenance functions and terminology used in the binary autosampler. This information is available in the Agilent autosampler reference manual and user guide.

The plumbing of the autosampler as a fixed loop autosampler is very different from the open or broken loop design documented by Agilent. Please be aware of these differences and follow this documentation completely.

WARNING	When opening capillary or tube fittings, solvents may leak out. Please observe appropriate safety procedures (for example, goggles, safety gloves and protective clothing) as described in the material handling and safety data sheet supplied by the solvent vendor, especially when toxic or hazardous solvents are used.
----------------	--

Parts Required

A 9/64" hex wrench. Two 1/4"-5/16th" wrenches for capillary connections.

All of the parts required to adapt an Agilent autosampler for use with the SFC Fusion™A5 are supplied with the A5 in the Std/WP ALS Compatibility Kit.

Table 3.2

A001	1	Agilent Std/WP ALS Compatibility Kit
00-81-5010	1	BCD Board
00-84-2040	1	Relay Cable, HD15M/F (VGA type), 6'

00-73-6020	1	Sample Loop, 5 uL with Fittings
00-73-3010	1	3 Groove Rotor Seal
A5-69-4120	1	Wash Pump Transfer Line
00-73-2060	1	Check Valve - Outlet , 15psi, 10-32
00-41-0320	1	Union - PEEK, (.020), 1/16" x 1/16"
A5-69-4050	1	Wash pump Inlet Line Assembly
00-41-2510	1	Bottle Filter
00-74-5010	1	Syringe - 10cc, Disposable
00-41-3530	1	Adapter - Female slip Luer to Female 1/4-28
00-41-3540	1	Adapter - Female slip luer to female 10-32

The first task in the conversion is to disassemble the injector valve (shown below) to access and replace the Rotor Seal. Aurora supplies a specific rotor that is different than others that may be supplied in the Agilent catalog. Use of rotor seals other than the Aurora supplied one may result in carryover between samples.

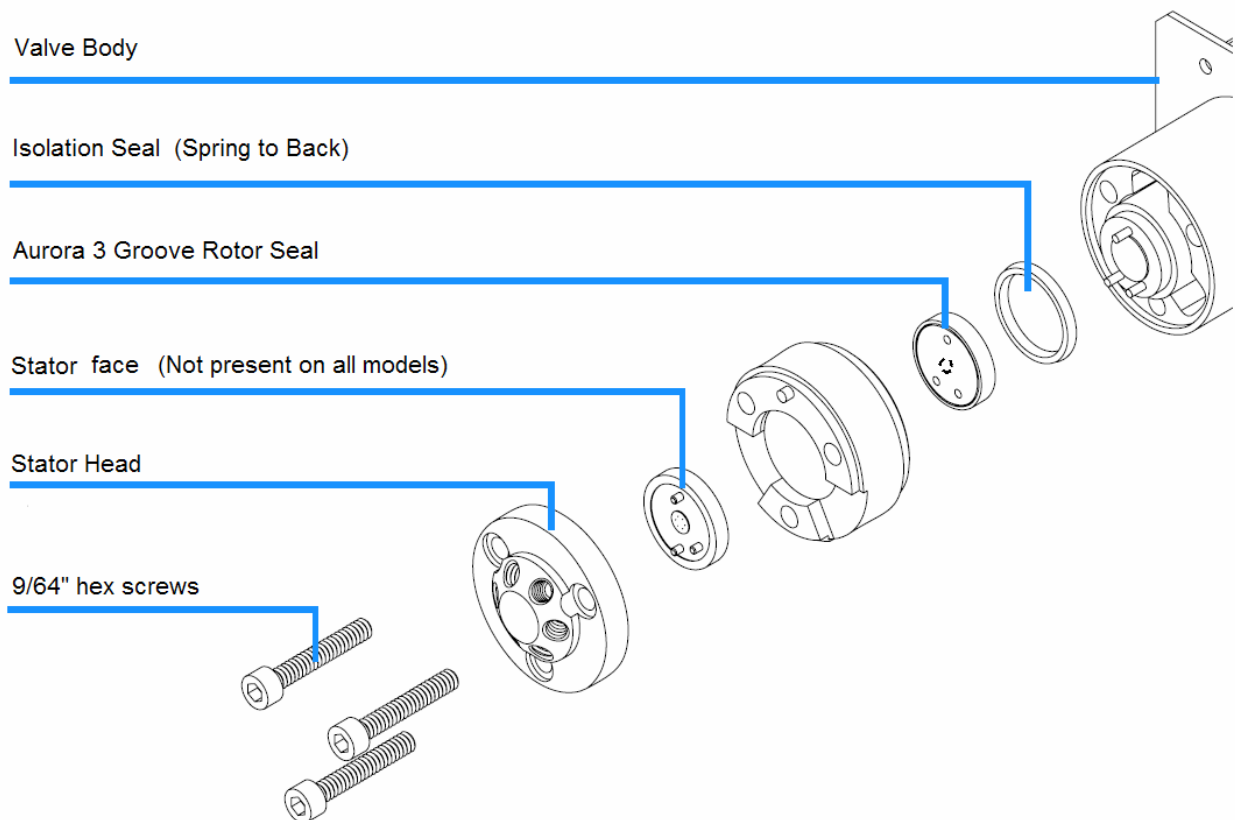

Figure 3.9 Exploded View of the Autosampler Injection Valve

WARNING When opening capillary or tube fittings, solvents may leak out. Please observe appropriate safety procedures (for example, goggles, safety gloves and protective clothing) as described in the material handling and safety data sheet supplied by the solvent vendor, especially when toxic or hazardous solvents are used.

The task of replacing a rotor seal is well documented in Agilent manuals, and service videos. Please refer to these guides for further assistance.

Remove all capillaries from the injection valve.

Loosen each of the three 9/64th inch hex bolts. Alternate two turns on each one to remove the stator in a parallel fashion. Do not completely remove one bolt without loosening the other bolts in turn.

Remove the stator head, stator face, and stator ring.

Remove the old rotor seal and isolation seal.

Install the new Aurora supplied rotor seal and the isolation seal. The spring in the isolation seal should face backwards, towards the back of the instrument.

Install the stator run with the shorter of the two pins facing front at the 12 O'Clock position. Ensure that the stator ring fits flat on the valve body.

If the autosampler has a separate stator face, place it on the stator head.

Install the stator head and face against the injection valve. Alternately tighten each of the three bolts two turns at a time until the stator head is securely fastened.

Swage one end of the sample loop into port 5 of the injector. Then remove.

Swage the other end of the sample loop into port 2 of the injector. Then remove.

With the fittings swaged onto the loop, the loop may be bent to allow both ends to fit simultaneously into the stator head.

Plumb the needle seat capillary into position 3.

Plumb the waste line to position 4. Direct the waste line through the over flow drain tube.

Plumb port 1 with the line going to the column (oven)

Plumb port 6 with the high pressure line coming from the binary pump.

Install the 10-32 male check valve end into the outlet (upper) port of the injection wash pump on the Fusion A5.

Connect one end of the wash pump transfer line to the 10-32 female port on the check valve just installed in the injection wash pump.

Before connecting the union end of the wash pump transfer line, use a syringe and luer adapter to prime (pull sample through) the injection wash pump.

The existing line (likely blue) from the inlet of the Agilent Autosampler's metering device can be plumbed into the union on the wash pump transfer line.

The autosampler should be plumbed following the diagram below.

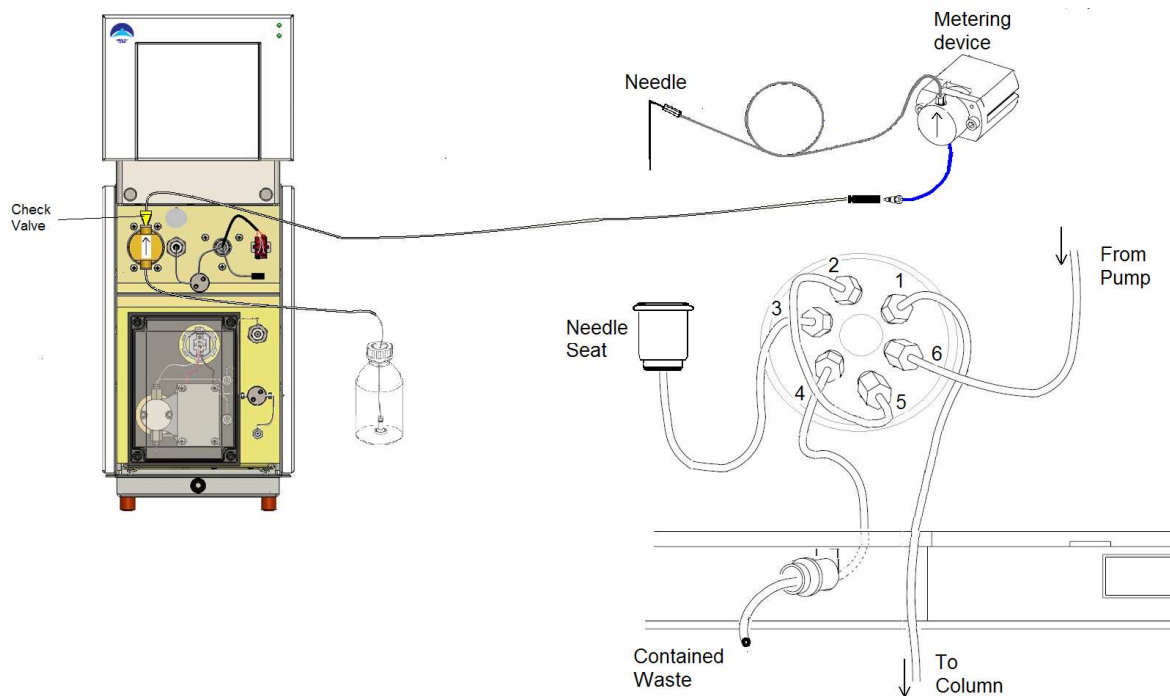

Figure 3.10
Autosampler Fluidic connections

Installing the sample loop

Proper swaging of fittings is important. The sample loop is not bent to directly fit into the valve stator head. It will have to be bent to shape to accomplish this. Prior to bending the loop, individually swage each end of the loop to insure proper pilot depth. Incorrectly installing the loop can lead to carryover and broadening difficulties.

The 5uL sample loop, Aurora PN. 00-73-6010, is plumbed between ports 2 and 5.

Positioning the waste line

In normal operation, the sample loop is switched from being in the high pressure flow stream (mainpass) to being out of the flow stream and connecting to the seat capillary and waste (bypass). As the valve switches, the fluid in the loop will expand and rush out of the loop through the waste line. If the waste line is positioned to empty into a liquid reservoir such as a WPA flush port, the exiting fluid from the sample loop could splash the flush port fluid across the als. The preferred positioning of the waste line is through the leak vent. In this position, the expanding fluid harmlessly exits into the leak tubing.

Alternatively, a waste line can be fabricated that empties into the Fusion A5's gas liquid separator (waste bottle).

Under no circumstances should this line be allowed to be unconstrained. During operation of the injection wash pump, this is the final exit of the wash fluid.

Installing the Agilent BCD Board

A means is required to tell the wash pump when to wash. This is accomplished using a standard board (Aurora PN 00-81-5010) and cable (Aurora PN 00-84-2040) available from Aurora. However, Aurora has included this board and cables in the ALS ship kit.

Agilent HPLC modules have a small compartment located on the back panel near the top, with a cover held in place by two captured knurled nuts. Loosen the nuts and remove the cover taking care to retain it for future use.



Figure 3.11
BCD Interface Card

Locate the BCD board in the ship kit. As with all electronic boards be careful not to damage it with static electricity, solvent, etc.

Caution Follow all recommended ESD precautions when handling electronic PC Boards and components.

Carefully slide the board into the slot. When it bottoms out, gently push the bezel until the connectors engage. Tighten the captured knurled nuts.

With the BCD card in place, connect the 15 pin relay contacts connector to the relay input connector on the back of the Fusion A5.

Connect the 9 pin Remote connector on the back left of the autosampler to the 9 pin Remote connector on the back of the A5.

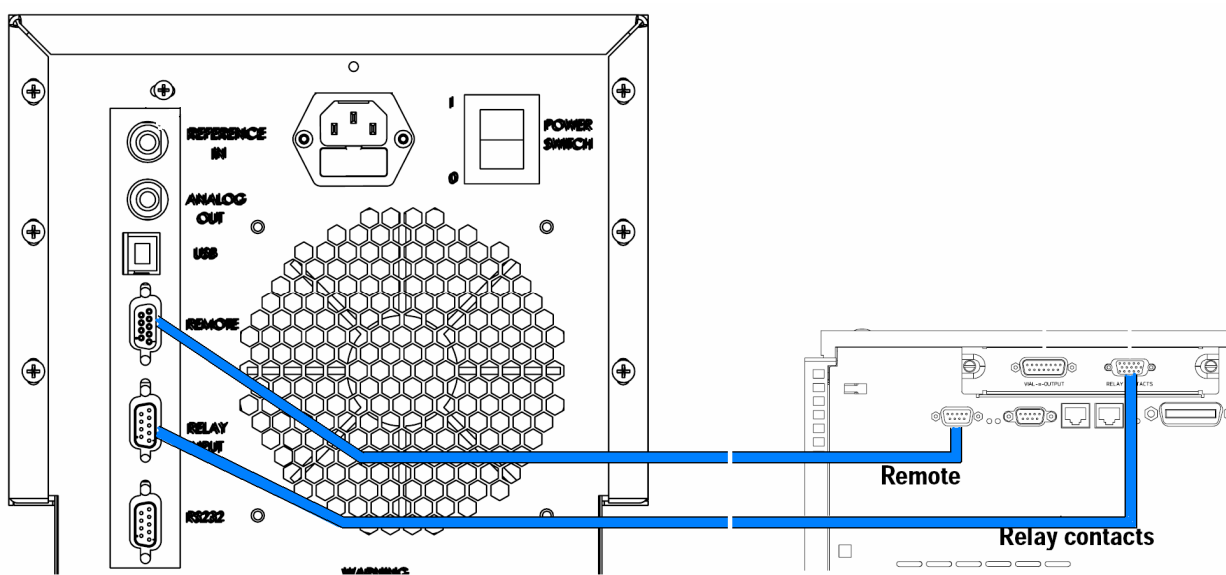

Figure 3.12
Autosampler Signal Cable Connections

Installing an Injection Program in the Method

Table 3.3
**Agilent 1200 High Performance Autosampler
Injector Program**

Injection	
Injection Volume	13.0 µl
Injection Mode	Injector Program
Time	
Stoptime	No Limit
Posttime	Off
High Throughput	
Autom. Delay Vol. Reduction	Off
Overlapped Injection	disabled
Minimized Carry Over	Off
Needle Wash	
Wash Mode	Wash in Flushport
Wash Time	1.0 s
Wash Location	Vial 10
Repeat	1 times
Injector Cleaning	
Injection Valve Cleaning / Valve Switching	
Time 1 Bypass	off
Time 2 Mainpass/Bypass	off
Time 3 Mainpass/Bypass	off
Time 4 Mainpass/Bypass	off
Valve Movements	1
Auxiliary	

Draw Speed	100 µl/min
Eject Speed	100 µl/min
Draw Position	0.0 mm
Equilibration Time	2.0 sec
Sample Flush-Out Factor	5.0 times Injection Volume
Vial/Well Bottom Sensing	No
Store Temperature	No
Injector program table	
Row	Action
1	NEEDLE down
2	CONTACT B CLOSED
3	WAIT 0.10 min
4	CONTACT B OPEN
5	VALVE bypass
6	DRAW 1.5 µl from air, def. speed
7	DRAW def. amount from sample, def. speed, def. offset
8	DRAW 3.0 µl from air, def. speed
9	NEEDLE wash as method
10	EJECT max. amount into seat, def. speed
11	VALVE mainpass + start pulse
12	CONTACT B CLOSED
13	WAIT 0.10 min
14	CONTACT B OPEN
Agilent Contacts Option	
Contact 1	Open
Contact 2	Open

Contact 3	Open
Contact 4	Open

NOTICE

Modifying Agilent autosamplers from broken loop to fixed loop autosamplers has several minor consequences that need to be understood for adequate performances

Potential for Carry-Over

Agilent sells a 3-groove rotor superficially resembling but NOT equivalent to the Aurora SFC Systems 3-groove rotor. The Agilent rotor has one of the grooves slightly extended in length to facilitate a partial “make-before-break” connection. The Agilent rotor is designed to be used in a different context than the Aurora approach. Using the Agilent rotor instead of the Aurora rotor WILL result in carry-over, unless a substantial volume of injector valve wash solvent is used between injections. The extra length of the groove effectively acts as a poorly swept mixing chamber, since the mobile phase does not directly flow through the whole volume.

Using the Aurora standard 3-groove rotor eliminates this source of carry-over, since it does not have this extra groove length. Using the Aurora 3-groove rotor substantially decreases the volume of solvent required to avoid carry-over.

Dead Volume-Partial Loop Injections

Plumbed as a loop injector the Agilent autosamplers have a dead volume between the high pressure needle seat and the groove on the rotor of the injection valve. There are 2 different diameter tubes to make this connection. Thus, the actual dead volume can have several different values, depending on which ID tubing is used. This dead volume can be several micro liters or more. When attempting to make smaller injections, NO sample may actually enter the loop unless provision is made to use two air bubbles, one on each side of the sample, insert a plug of modifier or other solvent behind the sample, etc.

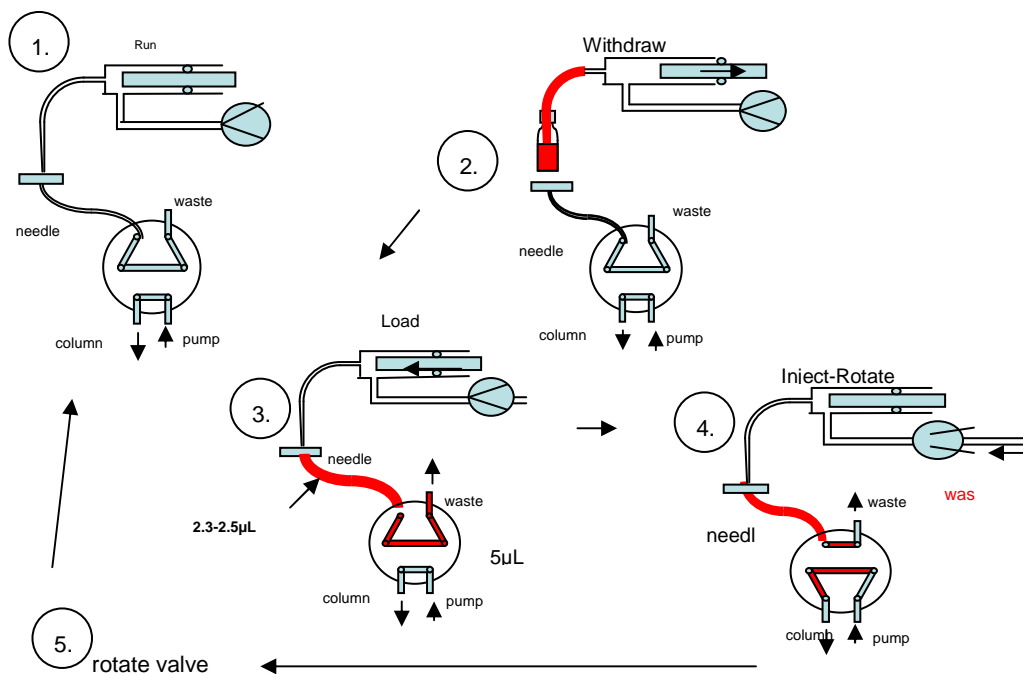

Figure 3.13
Full Loop Injection

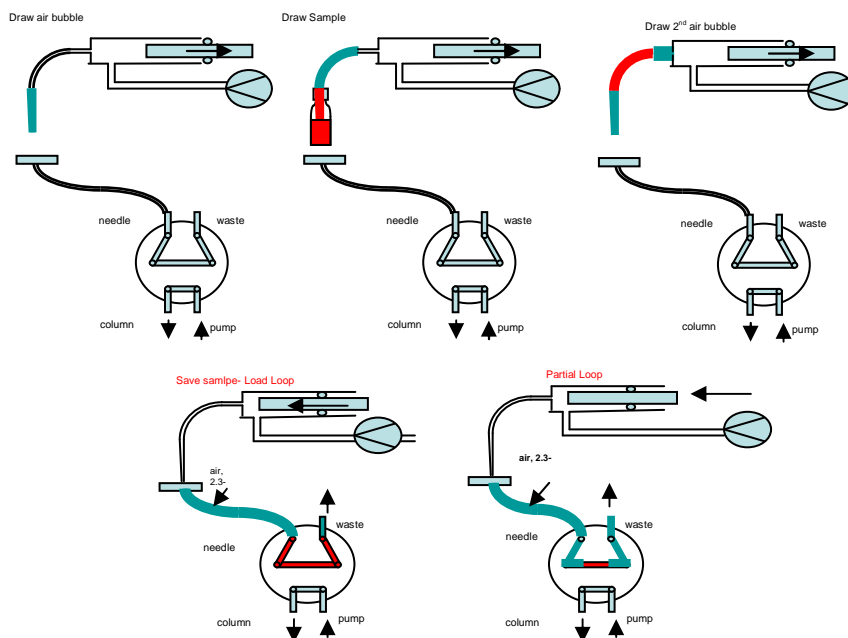

Figure 3.14
Partial Loop Injection

Some General Injection Rules

Many people use 20 μ L loops in HPLC. In SFC, the sample is often dissolved in a solvent that is stronger than the mobile phase. Injecting large volumes, such as 20 μ L, of such a solvent will cause peak distortion.

As a rule of thumb, no more than approximately 5 μ L of a polar solvent such as methanol should be injected onto a 4.6mm ID column, as shown in the figure below.

This should NOT have a major impact on area reproducibility but should destroy efficiency as indicated in the second figure below.

Use Small Loops

The loop should not be much larger than the maximum desired injection (or \approx <5 μ L). Remember the loop is washed with a strong solvent, and is usually filled with that solvent. The sample displaces all or some of this solvent.

If the loop is too large, too much strong solvent is injected, regardless of whether the loop is filled with sample or wash solvent. Peaks will be distorted. Efficiency will degrade.

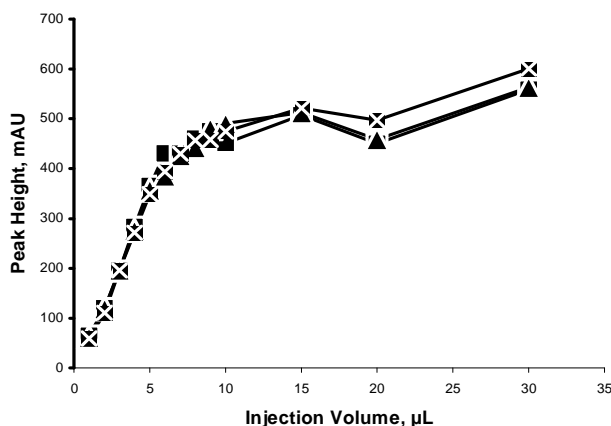

Figure 3.15
Plot showing loss of efficiency with large injection volume

If a large loop is used, air bubbles can be used to displace the wash solvent.

Less Polar Sample Solvents Help

Replacing the sample solvent with a much less polar solvent can allow injection of much larger volumes. However, the new solvent must be significantly less polar than the modifier used. Replacing methanol with ethanol or even isopropanol has minimal effect.

Solvents like chloroform or methylene chloride tend to cause significant focusing (NO broadening), but since they are chlorinated should probably be avoided.

Installing SFC Fusion A5

WARNING Do not connect AC power or interconnection cables or gas tubing to the Fusion instrument until these installation procedures direct you to do so.

Preparation

Before beginning the installation of the SFC Fusion™ A5, familiarize yourself with all instructions. This includes converting the various modules in the HPLC stack. All of the modules in the HPLC stack need to be cleaned and flushed prior to performing the SFC Fusion™ upgrade. It is easiest to perform this flushing and preparation before beginning required modifications.

If you have not previously done so, completely read and understand all of the operations regarding site prep, module conversion, and installation before continuing.

Locate all modules, devices and supporting equipment before continuing. Ensure that the supply tubing can reach a physically secured source of CO2. Ensure that adequate venting is available and with reach of supplied waste systems.

This document describes a particular order of plumbing the system. In this document, we will describe plumbing and electrical connections last. These operations are performed on the back of the systems. Depending upon your individual installation, you may wish to perform operations on the rear of the instruments first. This is perfectly acceptable, provided you can maintain access to supply connections to ensure integrity and leak tightness of fittings and connections.

Unpacking the Fusion A5

Damaged Packaging

When you receive your Fusion A5 inspect the shipping boxes for any signs of damage. If the shipping container or cushioning material is damaged, notify the carrier and save the shipping material for inspection. Save all materials until the contents have been checked for completeness and the instrument has been mechanically and electrically checked.

CAUTION If there are signs of damage to the Fusion A5 Module, please do not attempt to install or use the instrument.

Delivery Checklist

Compare the delivery checklist with the contents of the shipping boxes to ensure completeness of the shipment.

For parts identification check the illustrated parts breakdown in Chapter 5. Please report missing or damaged parts to your local Aurora representative.

Additionally, you may also receive other items and compatibility kits depending on options ordered. These options may include

High Pressure Flow Cell

- Mass Spectrometer Splitter

- Autosampler Compatibility Kit

- Gas Delivery System Interface Kit

The contents of these kits are detailed in other sections of this guide.

**Table 3.4
Fusion A5 Contents Lists**

Item		Quantity	
Fusion A5 Module		1	
A5-69-4080		1	A5 Tubing Kit
	00-42-5030	1	Tubing - Tygon, 3/8", (1/4")
	A5-60-9050	1	CO2 Supply Line Assembly
	A5-69-4090	1	A5 Waste Line
	A5-69-4010	1	A5 Pump transfer line Assembly
	A5-69-4070	1	A5 Return transfer Line
	A5-69-4060	1	A5 Leak Tray Waste Line
A5-60-9010		1	Fusion A5 Ship Kit
	00-77-2010	1	A5 Waste Bottle
	00-84-2050	1	USA Power Cord
	00-84-2030	1	Remote Cable, DB9 M/M
	A5-53-4000	1	Software Driver Disk
	00-84-2090	1	USB Cable - 6'
	00-26-1070	1	Wrench Set
	00-26-1060	1	Wrench - Adjustable, 6"
	00-26-1040	1	Wrench - Hex, 3/16"
	00-26-1050	1	Wrench - Combination, 1/4"
A5-60-9180		1	A5 Spares Kit
	00-73-1010	2	A5 Pump Seals; UHMWPE
	00-73-2010	1	Check Valve Cartridge; 0.125 ball
	00-42-2520	2	Nut - SS, 1/16"
	00-42-2020	2	Ferrule - SS, 1/16"
	00-83-5040	2	Fuse, 8.0A, 250V, slow blow
A5-53-3000		1	A5 Operation Manual
A5-53-1000		1	A5 Site Prep and Installation Guide

Connecting the Waste system to the Fusion BPR Outlet

The SFC Fusion™ A5 has a waste bottle located outside of the A5 cabinet. It can be located anywhere easily accessible and visible within the range of the supplied tubing.

The waste bottle served multiple purposes and collects liquid waste from multiple sources. The primary purpose is to separate the gaseous and liquid waste from the outlet of the bpr (system) in a manner that the gaseous waste can be appropriately vented outside of the lab environment. The waste bottle has input and output ports located above any collected liquids. The mixed stream enters the waste bottle and the gaseous stream exits out the spout.

WARNING Proper system operation requires adequate space in the waste bottle to allow gaseous exit. It is the responsibility of the operator to ensure that the waste bottle is empty before beginning operation of the A5 and to monitor and empty the waste bottle as needed during usage.

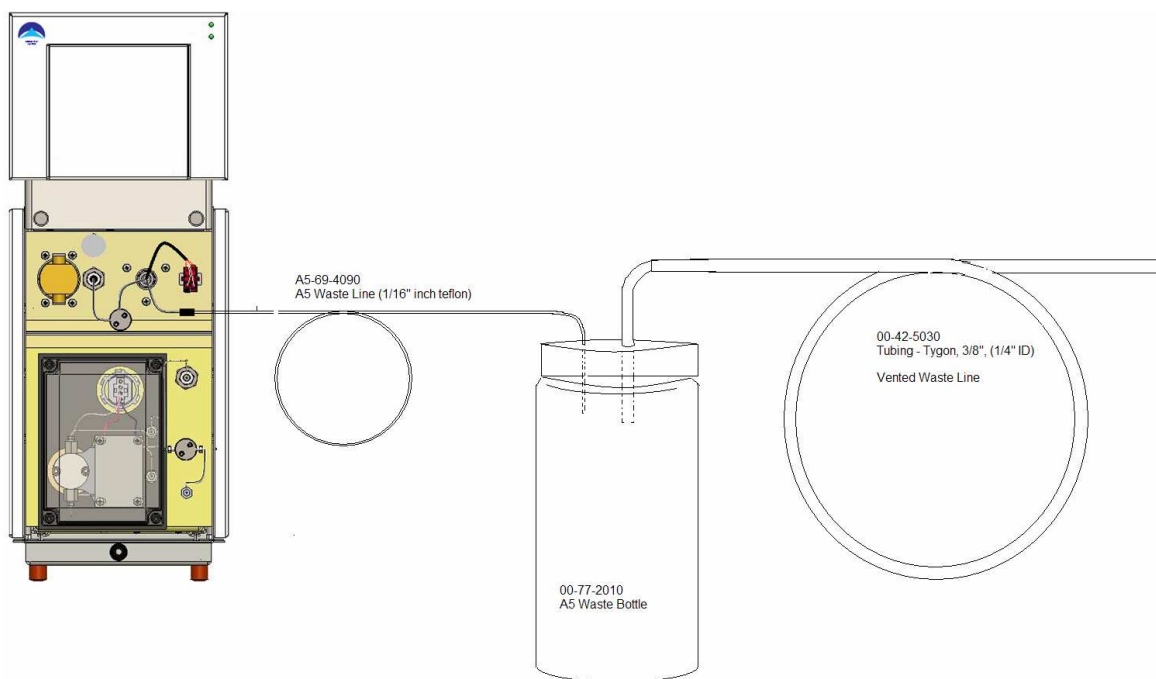

Figure 3.16
Installing the Waste Container

WARNING The vapor exiting the Fusion module may contain several % organic solvent. The effluent should NEVER be vented directly into an

enclosed space occupied by humans due to the potential for long term exposure to toxic substances.

Locate and assemble the Waste bottle and Tygon vent tubing. The vent tubing can be placed over the spout on the top of the waste bottle. Route the Tygon tubing to an appropriate vent. The system must be actively vented.

Locate the A5 Waste line. Insert the free end through a hole in the top of the waste bottle cap. Insert the tube ½” into the waste bottle. Connect the fitting end to the outlet union on the BPR. This union utilizes a 10-32 CPI fitting. Tighten snugly.

Installing the Flowcell

The back pressure regulator exists after any detectors in the HPLC system. Thus, the detector flow cells (or splitter in the case on an ELSD or Mass Spectrometer), operate at an elevated pressure relative to HPLC.

CAUTION Verify that the cell installed in the detector is capable of the high pressures used in SFC. Exposing a standard HPLC flow cell to high pressures will result in damage to the cell.

Aurora offers a Diode Array Detector flow cell that has been extensively optimized for use in SFC. This cell is pressure rated and tested to 350bar. It contains extensive thermal conditioning not found in standard HPLC flow cells. Aurora’s cell is highly recommended for SFC usage.

The flow cell should already be installed in the DAD (or VWD). Carefully examine the inlet and outlet ports of the cells to ensure that flow is in the correct direction. In the DAD, the outlet port is customarily located below the inlet port on the connection block.

The inlet port of the DAD flow cell enters the stationary portion of the handle. This stationary bar acts as an initial thermal conditioning zone. Customarily, this port has a male fitting. The outlet port connects directly to the cylindrical portion of the flow cell. Customarily, this connection has a female fitting.

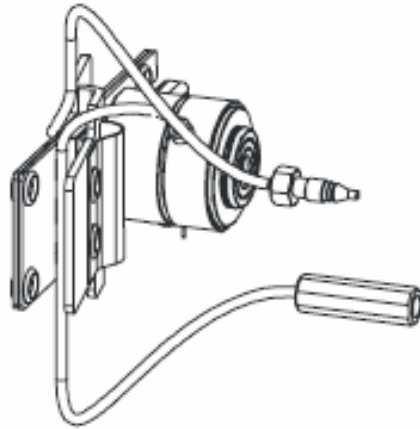

Figure 3.17
DAD High Pressure Flow Cell

Connecting the BPR to the HPLC Stack

Connect the A5 return transfer tube to the outlet block of the detector. This tube can then be routed out the concave opening in the bottom of the detector behind the detector cover. The return transfer tube should then be routed to the space between the HPLC stack and the A5. Move the tube upward between the units and through the upper tee-slot on the side cover of the A5. The return transfer tube can then be fastened in the right port of the tee in the lower center of the bpr drawer.

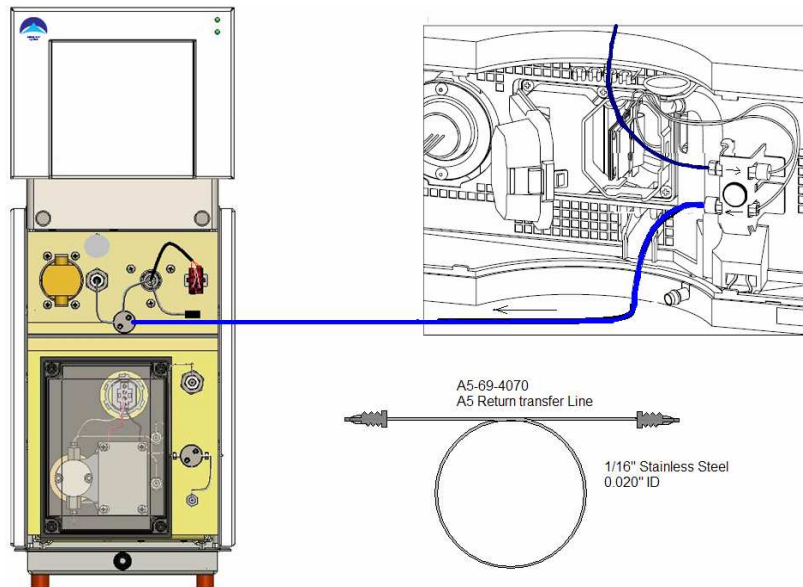

Figure 3.18
Connecting the A5 return Line

Connecting The Autosampler

If not already performed, Agilent Autosamplers need to be converted for use with SFC. Please reference the installation and upgrade section of the Autosampler compatibility kit for specific instructions.

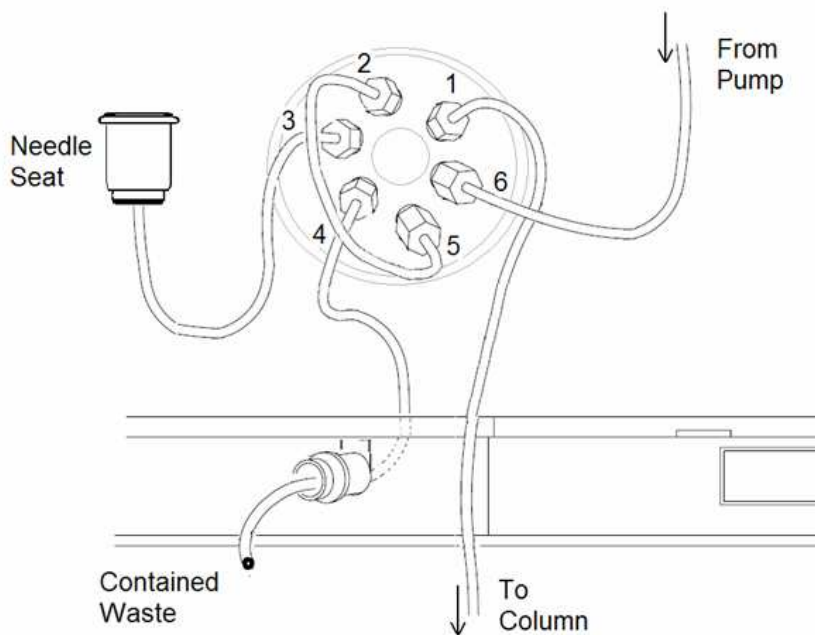

Figure 3.20
Plumbing the Autosampler

If the autosampler has been upgraded, the plumbing connections can be made to the injection valve.

In the fixed loop operation of the autosampler, all connections are made on the injection valve as shown. Port 1 is connected to the inlet of the right side (column pre-heater) thermal conditioning block of the oven.

Port 6 is connected to the combined output flow of the binary pump. This combined output is a port on the collar of the original purge/prime valve on the pump.

Connecting Booster To HPLC

The Binary pump should have already been modified to replace the Active Inlet valve with Aurora supplied check valves and holders. If the Binary Pump has not been

converted for SFC use, install the Binary Pump Compatibility kit before continuing. The active inlet valve shipped by Agilent is incapable of operating at normal CO₂ delivery pressures.

CAUTION Verify that the binary pump active inlet check valve has been replaced with the passive inlet check valve. Connecting the booster pump of the Fusion module to the active inlet check valve will result in damage to the active inlet check valve.

Locate the stainless steel booster transfer line. Connect one end to the top port of the output tee on the center right side of the booster drawer. Tighten finger tight and then an additional 1/8th turn as needed.

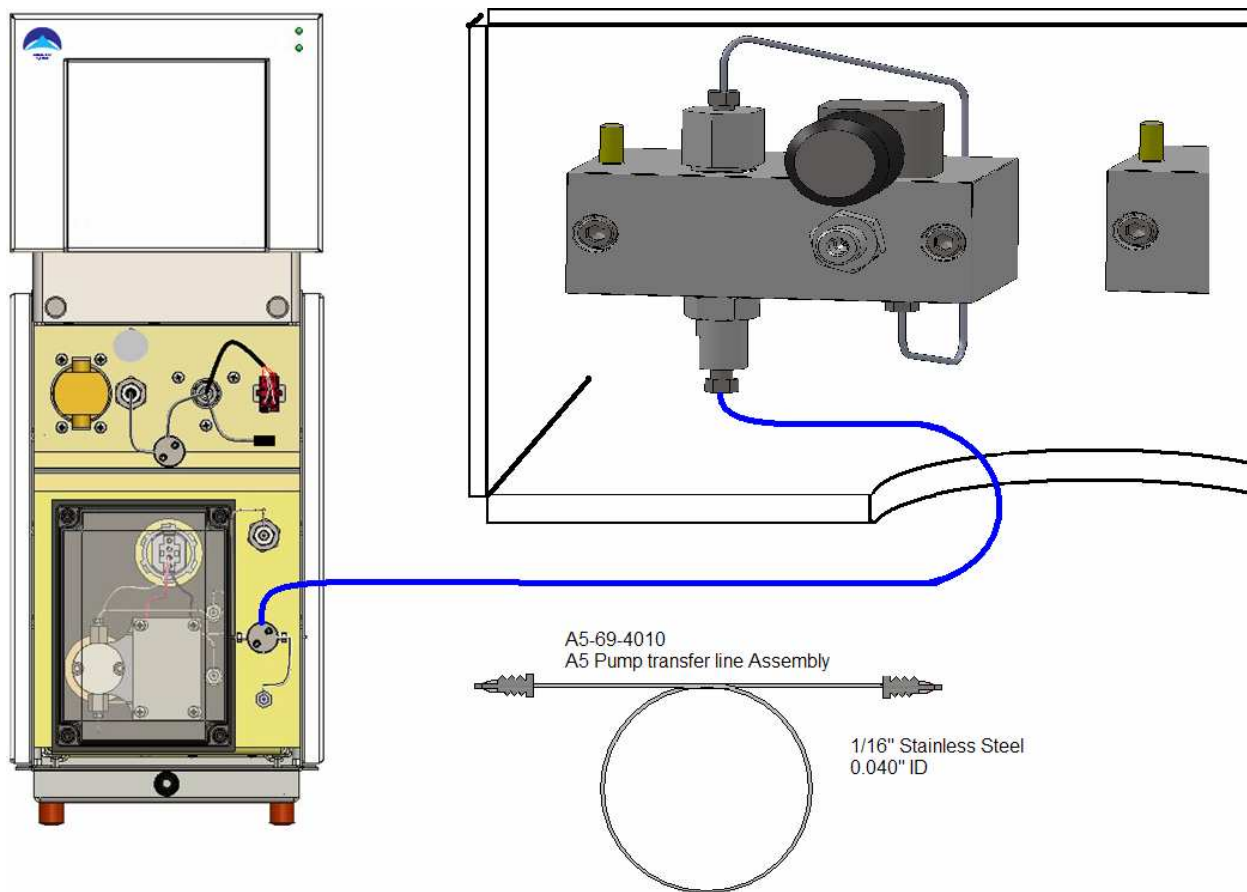

Figure 3.21
Connecting the Booster outlet line

This tube can be routed through the tee slots on the side of the A5. The tube will travel upward between the A5 and HPLC stack to the bottom side of the binary pump. The tube

will then be routed horizontally to the bottom center of the binary pump where it can enter in the concave opening behind the cover. The tube should then be routed to the left side of the pump beneath the Channel A (left side) inlet check valve. The end of the booster transfer tube can then be installed in the inlet check valve holder.

Any spare tubing can be located between the A5 and HPLC stack.

The Injector Wash Pump

The wash pump is only required with autosamplers normally operated as “broken loop” autosamplers, converted to fixed loop autosamplers. The injector wash pump needs to be plumbed to a source of wash solvent. This wash solvent is used to prime the injector system to assure proper operation while aspirating sample. It is also responsible to wash the injection system (needle interior, needle seat, injection valve, and sample loop) in between injections.

The injector wash pump is connected to a (supplied) bottle filter through the wash pump inlet line. The wash pump inlet file is connected to the lower port on the injector wash pump located on the left side of the bpr drawer. The other end should be connected to the bottle filter. The filter can then be placed in a user supplied wash solvent bottle.

The wash solvent bottle can be left on the bench or placed in the HPLC solvent tray. The wash pump is connected to the metering device (syringe pump) through a check valve intended to prevent siphoning. The operation of the check valve should be verified to ensure it is not leaking as this can cause a loss of injection precision.

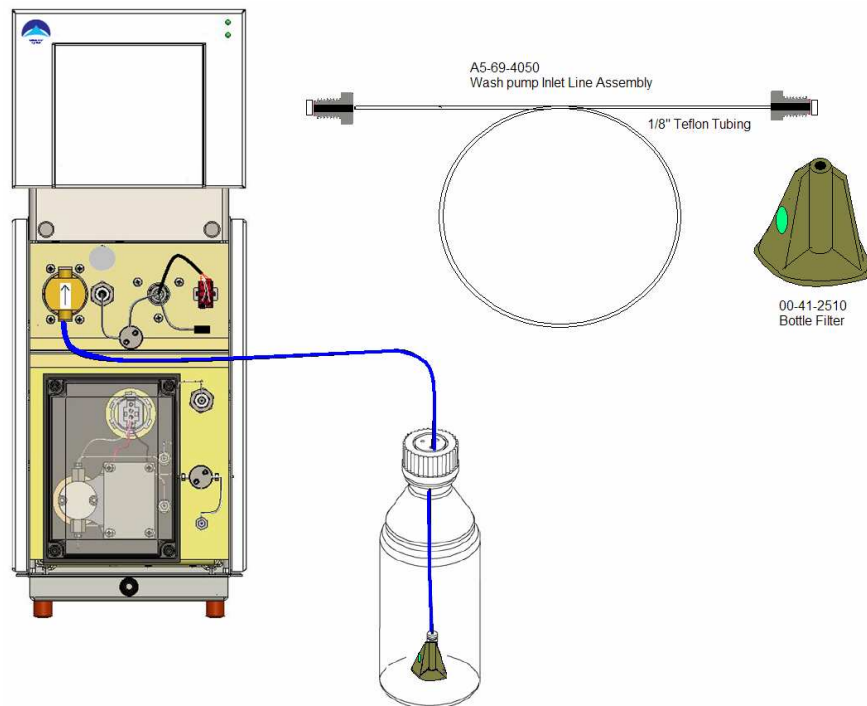

Figure 3.22 Connecting the Wash Pump Inlet

The outlet of the injector wash pump is connected to the metering device in the Agilent autosampler. To plumb the outlet side of the injector wash pump, locate the spring loaded check valve (00-73-2060) and install it in the upper port of the injector wash pump. Flow through the wash pump is in the upward direction. On the spring loaded check valve, the male end represents the inlet, and the female port represents the output. The injection wash system will not function if the check valve is improperly installed. An arrow embossed on the check valve body indicating the direction of flow. Verify that the check valve is tightly installed.

Connect the PEEK wash pump transfer line to the spring loaded check valve. A union is provided on the other side of the of the wash pump transfer line. Follow instructions below for priming the injector wash pump before connecting the union and the autosampler metering device.

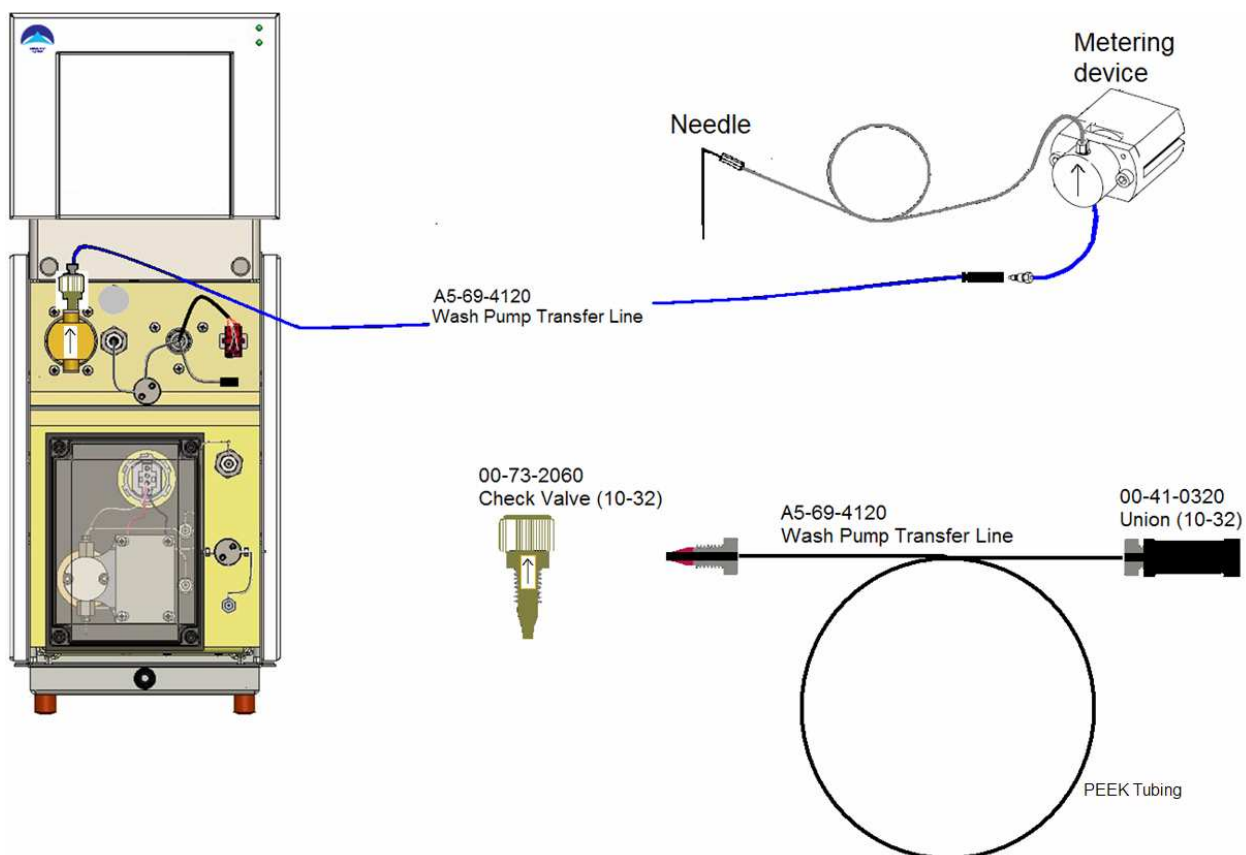

Figure 3.23 Connecting the Wash line and Check Valve

Priming the Injector Wash Pump

The wash pump is not self priming; it needs to be filled with wash solvent. See the plumbing scheme, above. There is an “extra” in-line check valve downstream of the wash pump. This check valve contains a ball pushed into the seat with a spring. The purpose of the spring is to prevent siphoning of the wash solvent from the container, through the injection valve to waste. With the check valve in place, it is easy to prime the injector wash pump without siphoning.

Once the PEEK wash pump transfer line and spring loaded check valve are connected to the injector wash pump, one can fill the pump through the injector wash pump transfer line. A syringe, and several Luer adapters are included in the ship kit (see drawing). The syringe, Aurora PN: 00-74-5010, can be connected to the check wash pump transfer line (once the union is removed) using the Luer adapter, Aurora PN: 00-41-3530. Retracting the syringe will pull solvent through the system, check valves, and tubing. This will effectively prime the injector wash pump. After completion, remove the Luer adapter, reinstall the union, and connect to the autosampler metering device.

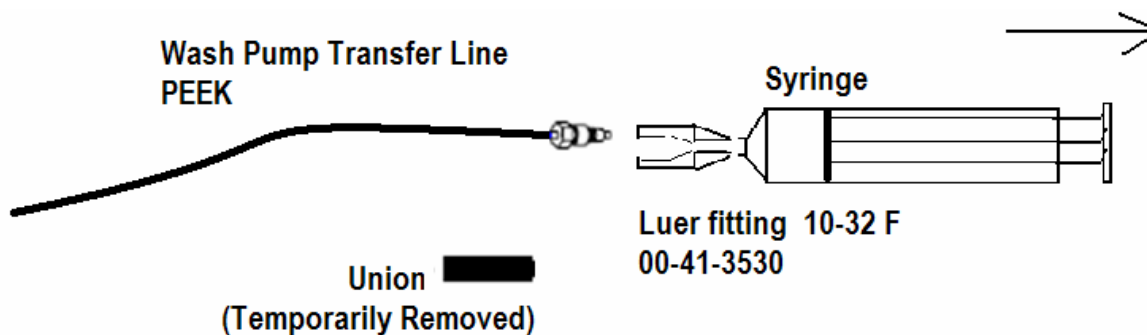

Figure 3.24

Connecting Fusion A5 to a Source of Carbon Dioxide

Fusion A5 has a 1/8th inch tube inlet connection on the lower left hand side on the back of the Fusion module. This connection is actually part of a very high surface area filter intended to intercept catastrophic levels of particulates. The user needs to connect this input to a source of carbon dioxide. The most common sources of carbon dioxide are liquefied carbon dioxide in a room temperature cylinder. At “room temperature” the pressure in the cylinder could change from a little above 50 Bar to just below 70 Bar. Unlike most SFCs, Fusion is immune to the variations in flow resulting from cylinder pressure.

WARNING Expanding carbon dioxide can become extremely cold capable of creating severe frostbite in short times. Avoid contact with expanding gases. Do not vent substantial quantities into the laboratory.

WARNING Carbon dioxide is poisonous at high concentrations and should only be used in well ventilated areas. The system effluent should be vented into a fume hood or to the outside. Evacuate if a large spill occurs. A carbon dioxide sensor/alarm is recommended.

Individual cylinders

WARNING Carbon dioxide in cylinders is partially liquefied, under high pressure and contains a great deal of energy. If containment is breeched (a break in the line or cylinder) the entire contents will vaporize and quickly expand up to 500 times in volume and create very forceful, high velocity gas streams. Cylinders must be properly constrained, and proper tubing used, to avoid damage that could generate projectiles.

Any industrial grade of carbon dioxide is acceptable provided it is supplied in a cylinder without a DIP tube. Drawing off the vapor phase leaves non-volatile contaminants behind in the cylinder. Using cylinders with a DIP tube subjects the chromatograph to contaminants soluble in the dense, liquid layer.

Larger tanks are more convenient in that they require less frequent change-out. Cylinders can contain 30 pounds, or 50 pounds, or even 70 pounds of CO₂. Roughly speaking, most 4.6mm columns are run at 3-5 mL/min, which is close to 2.5-4g/min of carbon dioxide. This is equivalent to 150-250g/hr; 1.2- 6Kg/day. Thus, a 30 pound cylinder should last 2.2 to 11days; a 50 pound cylinder would last 4 to 19 days; and a 70 pound cylinder could last 5.3 to 27 days - all depending on use (3-5ml/min; 8-24hr/day). For individual users, particularly new users, the use of cylinders is perfectly acceptable. Larger groups should consider installing a gas delivery system and a bulk storage tank.

Locate the cylinder in as close proximity as possible to the instrument. In the past, the cylinders were stored at much higher temperature than the lab temperature which resulted in vaporization in the supply line coming into the lab. Most SFC pumps cannot condense this vapor and therefore, cannot deliver CO₂. Fusion has a very powerful condenser designed to accept vapor phase CO₂. Nevertheless, it is always advisable to not stress any equipment.

Facilities and Safety personnel often wish to store and mount the cylinders outside the lab - sometimes quite far from the intended location of the instrument. They should recognize

that the transfer lines can hold large volumes, equivalent to a large fraction of a cylinder, particularly if tubing with large ID is used. Shut off valves on both ends of a transfer line are not recommended, unless one or both has a pressure relief valve or burst disk.

Be sure the cylinder is properly constrained and cannot tip over. Suitable chains or cylinder straps are required.

Cylinders in the USA and Canada use a CGA 320 cylinder adapter. One is included in the Fusion USA ship kit, along with a 1/4inch FNPT to 1/8th inch compression fitting, and 6 feet of 1/8th inch OD stainless steel tubing. The filter fitting sticking out the back of the Fusion module contains 1/8th inch nut and ferrule(s), which could be used with the Aurora supplied 6 foot tube, or a longer, user supplied, tube, to connect a cylinder to the Fusion module.

There are a multitude of different European “standards” for the connection to carbon dioxide cylinders. Aurora recommends that customers in Europe to contact their gas supply companies and ask them how to mate the cylinders they supply with an American 1/8” OD supply line.

WARNING Carefully check tank and inlet fittings for leaks. Any leaks present in the supply line and inlet fitting will not be sensed or protected by safety features in the SFC Fusion™ A5.

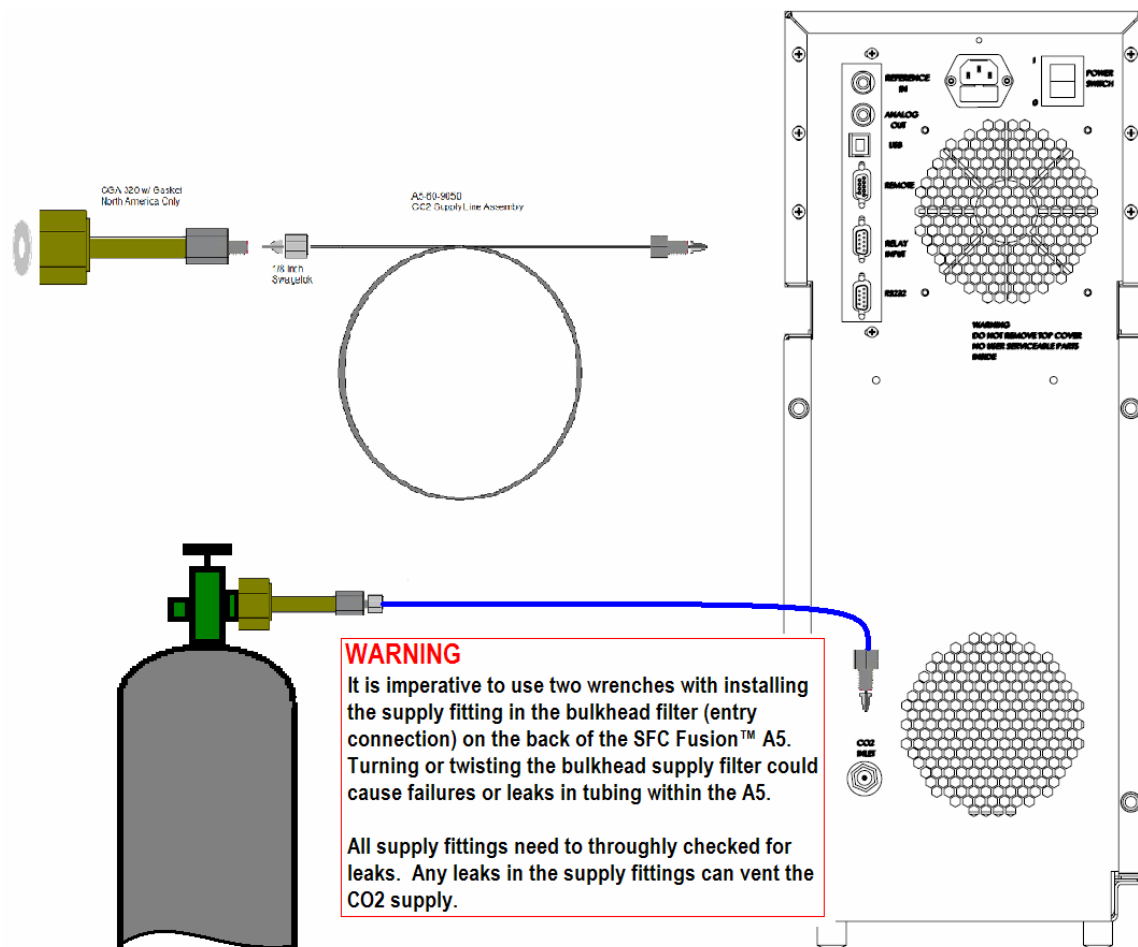

WARNING
 It is imperative to use two wrenches with installing the supply fitting in the bulkhead filter (entry connection) on the back of the SFC Fusion™ A5. Turning or twisting the bulkhead supply filter could cause failures or leaks in tubing within the A5.
 All supply fittings need to be thoroughly checked for leaks. Any leaks in the supply fittings can vent the CO2 supply.

Figure 3.25

WARNING It is imperative to use two wrenches with installing the supply fitting in the bulkhead filter (entry connection) on the back of the SFC Fusion™ A5. Failure to provide backup torque to the supply filter could allow it to spin while tightening the supply line fitting. Turning or twisting the bulkhead supply filter could cause failures or leaks on tubing within the A5.

Gas Delivery Systems (GDS)

Anyone performing semi-prep SFC has probably been convinced that operation without a GDS is problematic. Thus, many laboratories are now plumbed with carbon dioxide

boosted to 70 to 80 bar outlet pressure. Even though an analytical system does not need such a GDS, it is perfectly adapted to its use.

Aurora Fusion has an inlet safety shut-off valve rated to 1500 psi (>100Bar). While this rating is well above the outlet pressure of any typical GDS, past experience suggests it is wise to allow for some extra margin. Aurora suggests setting the local output of any GDS between 60- and 70-Bar, through local outlet pressure regulators.

Under these conditions, the GDS will almost always provide liquid carbon dioxide to the chromatograph. Unlike some earlier, systems, the Fusion module will easily condense any fluid that is actually present as a vapor, and prevent pump cavitations.

Cable connections to the HPLC

WARNING Ensure that the AC power cord is NOT yet connected to the Fusion instrument.

Cable connections to the SFC Fusion™ A5 are dependent upon the installed configuration. The primary decision to be made is whether or not an Agilent autosampler is present. When an Agilent autosampler is present, the Fusion A5 remote line and relay contacts lines are connected to the autosampler.

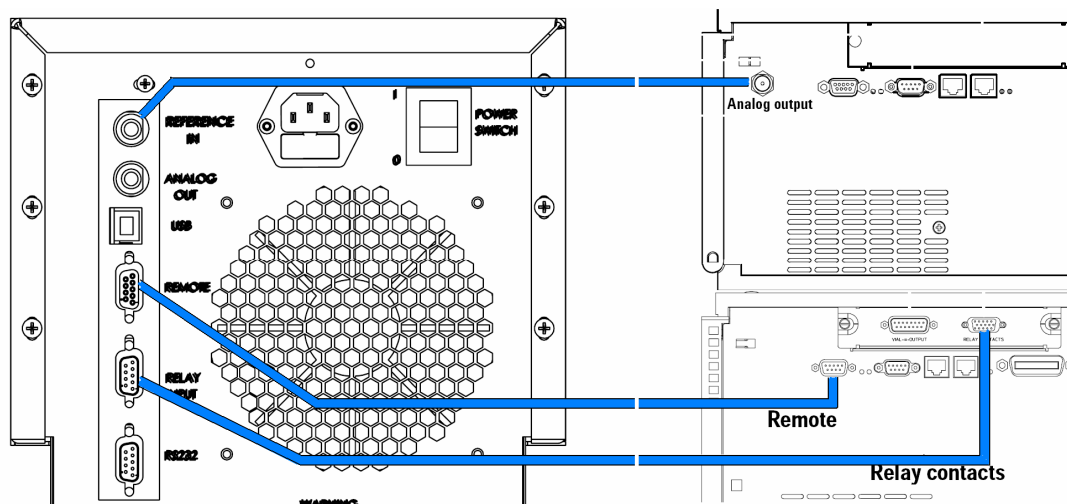

Figure 3.26
Reference, Remote and Relay Signal Connections

When the system is using a NON-Agilent autosampler such as a CTC Pal, the remote line is connected via a WYE cable to the remote connection on the binary pump.

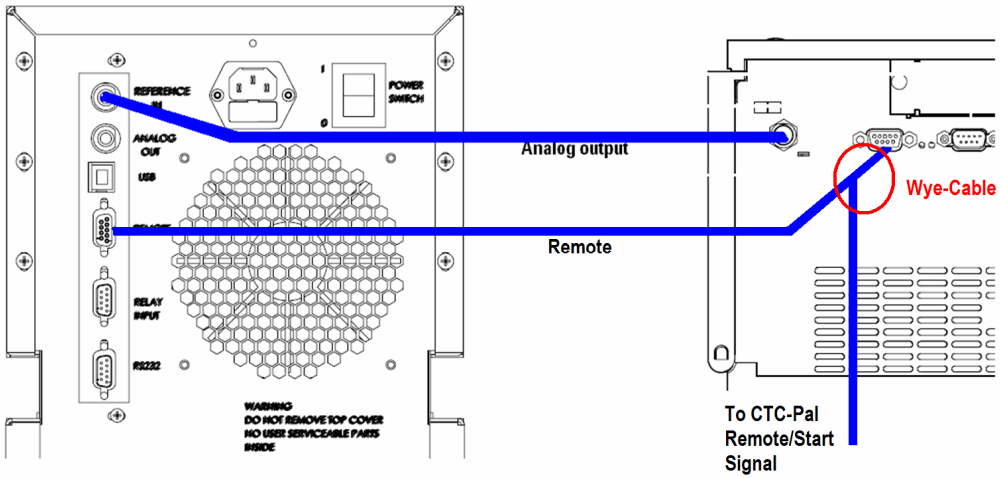

Figure 3.27
Alternative Remote Connection with Y cable

In either case, the Binary pump's analog output signal should be connected to the Fusion A5's reference in terminal.

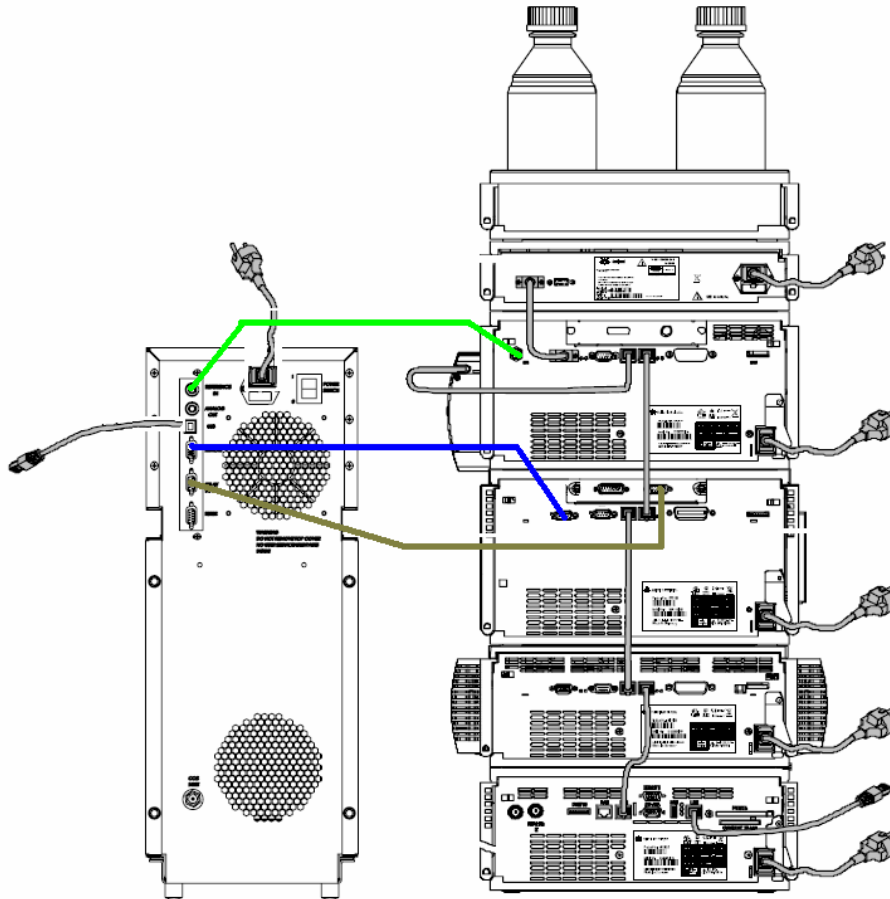

Figure 3.28

Lastly, the USB cable should be connected to the Fusion A5 USB port. This can be run to any convenient, compatible USB port on the PC.

CAN cabling between the modules of the HPLC stack is described in the HPLC module's reference manuals. This is unchanged from the normal, recommended means of interconnecting HPLC devices.

The HPLC stack will still require a LAN connection to the PC. This LAN connection will still require all the normal HPLC/Chemstation properties such as BOOTP, Firewall, and IP Address settings. This remains unchanged in a Fusion installation.

Connecting and operating multiple instruments on a single PC is not supported. Both the Fusion USB and HPLC Lan connections must be made on the same PC that Chemstation will be installed on and used for instrument control.

Connecting the Leak Tray Waste Line

The SFC Fusion™ A5 contains a Leak Tray on the bottom of the instrument to collect and sense any liquid spills that may occur in the A5 cabinet. In the bottom of this leak tray is an active sensor that continuously monitors for liquid presence.

The drip tray contains an overflow drain to divert any large amounts of collected liquid to an external collection means. The overflow tube incorporates a simple push-to-connect fitting. It is connected to the port on the bottom center on the front of the instrument. Pushing on the outside ring of the port facilitates removal of this line.

Since this liquid may be organic solvents, an appropriate collection container should be supplied by the user.

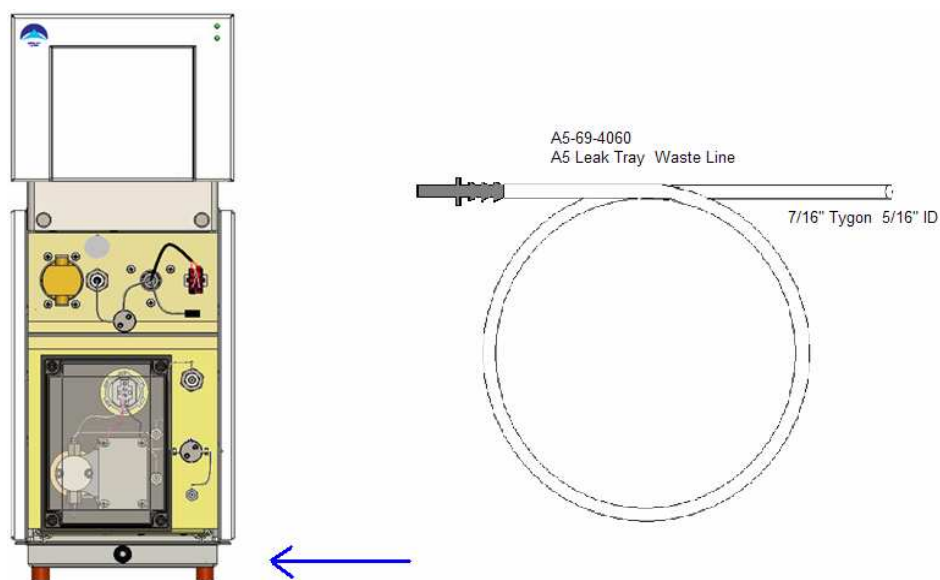

Getting Ready to Run the Instrument

Check to make sure all relevant signal cables between Fusion and the HPLC are in place;

Connect the AC power cord, Aurora PN 00-84-2050 (US/Canada only), to the Fusion instrument;

Connect the AC power cord to an appropriate wall outlet;

Turn on the Fusion instrument and observe the front panel LEDs.

Description of tests to run

Install the Fusion add-in Software

Locate the Fusion CD in the Aurora Ship Kit;

Place the CD into the CD reader on the computer running the Agilent Chemstation;

Follow prompts to copy and install the Fusion software.

Software Installation

The Aurora SFC Fusion™ A5 communicates to a host PC via a Universal Serial Bus (USB) interface. The installation of a high speed USB 2.0 port is recommended. Support for USB in Windows XP, Windows Vista, and Windows 7 is sufficient for reliable device communications. USB support in Windows 2000 is incapable of robust and reliable device operation and is neither recommended nor supported.

Installation of the A5 software requires that a version of Agilent Chemstation (Version B.02.01 or newer) is pre-installed and configured. The A5 software will not work with prior versions of Chemstation. Obtaining and performing an initial installation of Agilent Chemstation is beyond the scope of these instructions.

Installation of the Aurora software involves three tasks.

The first step is to configure Chemstation to support the SFC Fusion™ A5 (CIC based) driver. The second step is to configure the Universal Serial Bus driver to allow the A5 to be recognized by the Windows operating system.

Lastly, the address of the connected A5 module is supplied to Chemstation.

Installing SFC Fusion™ Driver Software

A software installer CD is included with the Fusion A5. Locate this disk and place it in a CD Rom drive. You can then navigate to the SW.x.x directory where you will find a windows .msi installer file and a matching setup.exe file.

Double Clicking on the Setup.exe file will begin the installation.

The installer is a multipurpose tool that will install the driver components initially if not previously present. If the Fusion components are already present, options will be presented to remove or repair the current files.

If prior versions of the SFC Fusion components are present, the installer will automatically upgrade the installation to the version present on the CD Rom.

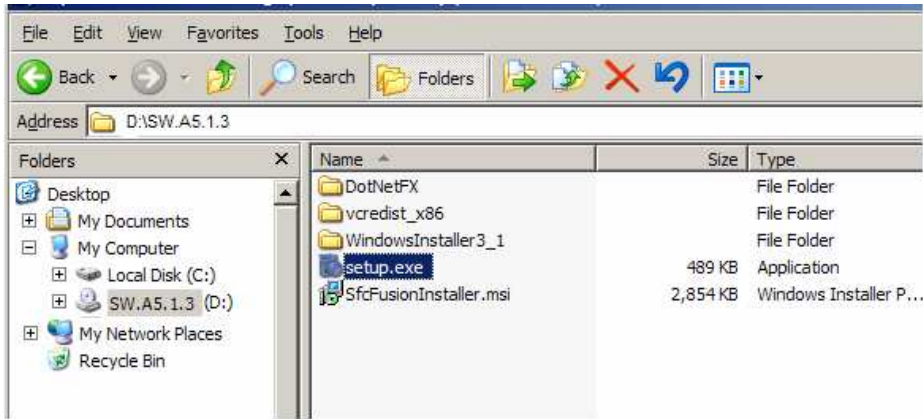

Figure 3.29

The installation begins by installing pre-requisite packages needed by the Fusion A5 software. These steps are required for proper operation. Pressing cancel or otherwise preventing complete installation will leave Fusion in a non-operational state.

The pre-requisite packages that may be installed (unless already present on this PC) are Visual C++ runtime libraries, Windows Installer, and the Microsoft .Net Framework (2.0)

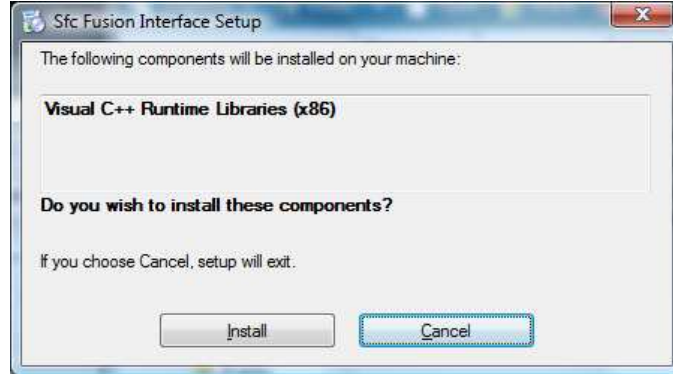

Figure 3.30

Once all pre-requisite packages are installed, the installer wizard will begin installation of Fusion components.

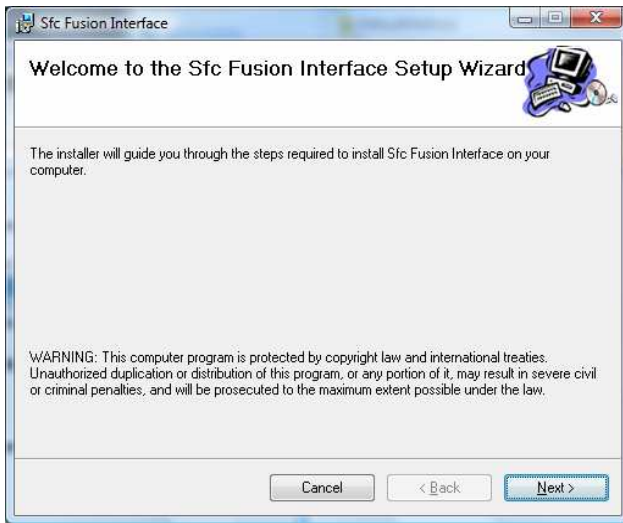

Figure 3.31

The SFC Fusion driver components need to be installed in the Agilent ChemStation directory tree. Please specify the location of the Chemstaion files in this dialog box. The normal location is in C:\Chem32.

If an incorrect location is specified, the installer will recognize the error (later) and roll back the installation.



Figure 3.32

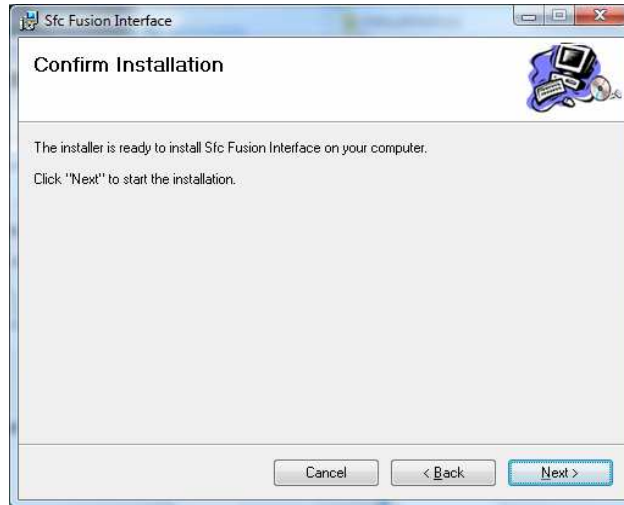

Figure 3.33

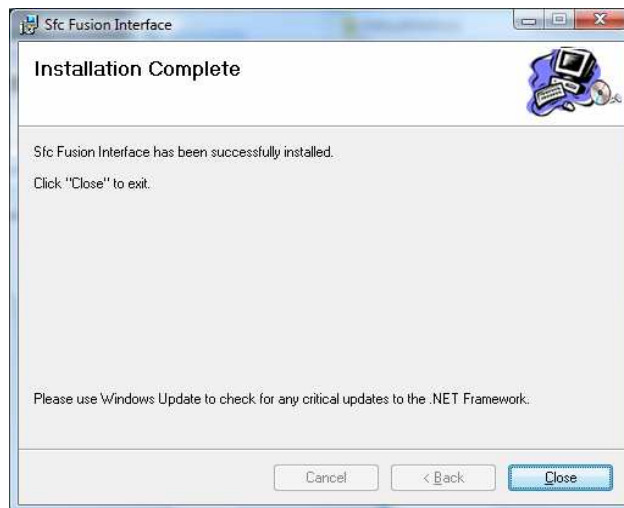

Figure 3.34

At this point all of the driver files are installed and ready to use. An icon will be placed on the desk top for the Aurora Diagnostic and Maintenance Utility. A link to the diagnostic utility will also be placed in the start menu.

Installing the SFC Fusion™ A5 USB driver

As mentioned, the Aurora SFC Fusion™ A5 communicates to a host PC via a high speed USB 2.0 port. This USB connection is pervasive on most all modern PCs. If the PC is not current enough to have a USB port built in, it is likely to be too old to reliably operate chromatographic instrumentation. In such a case, the user should consider obtaining modern hardware.

Once the Fusion A5's USB connection is connected to a host PC and the A5 is powered on, the windows plug-n-play should begin the new hardware wizard. This wizard will help locate the correct files to complete the communication installation.

Windows may wish to search for a driver location, but will not likely be successful. You may skip this search by selecting no in the box below.

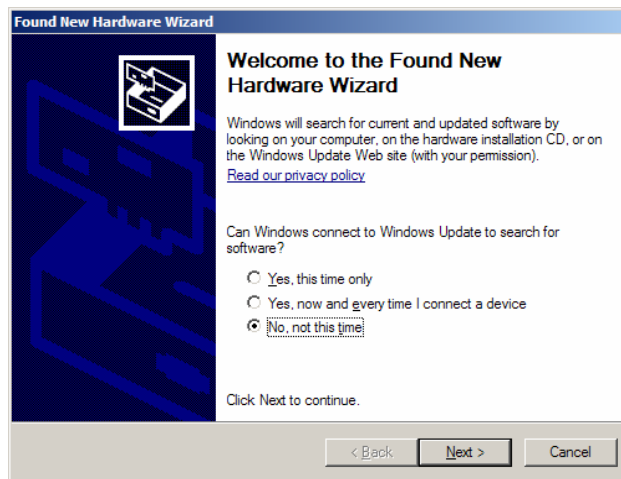

Figure 3.35

On new installations, the automatic search will not likely find the required driver file. On the next prompt, indicate that a specific location will be provided. This is labeled as an Advanced setting.

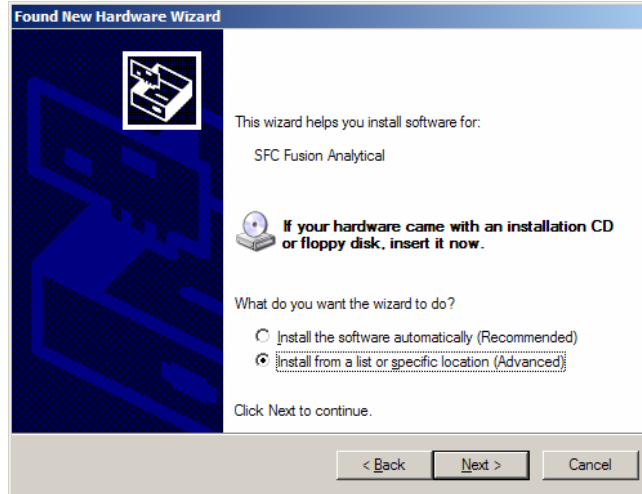

Figure 3.36

Having already run the SFC Fusion drivers, the required files can be found in the chemstation directory tree. As shown below, this is in the sub-directory `drivers\GCI\AuroraSfc\USB` off of the main chemstation. The required files also can be located on the root of the Fusion install CD.

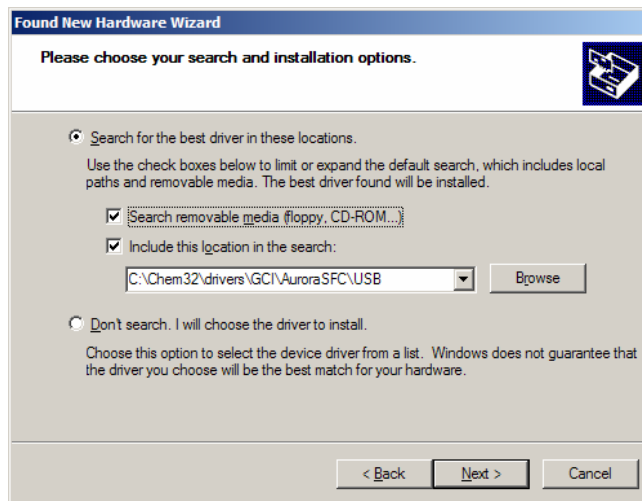

Figure 3.37

Windows will begin to install the Fusion USB driver but will stop requiring confirmation. A dialog box similar to these shown below will indicate that the driver's publisher cannot

be verified or logo testing has not been completed. This warning must be ignored and driver installation will continue.



Figure 3.38



Figure 3.39

Occasionally, an installation file's location (usbser.sys) may be requested. A version of this file can be found on the installation CD.

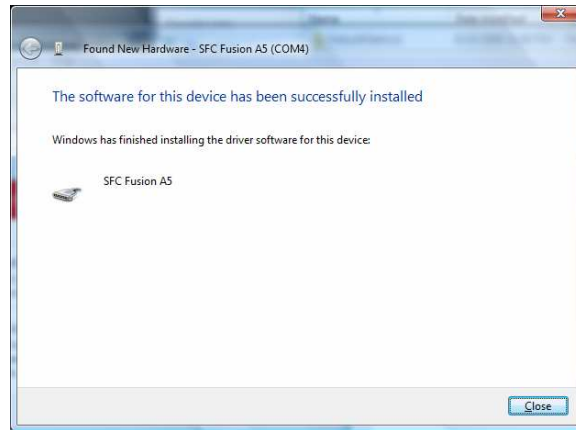

Figure 3.40

The device is now installed and its com port assignment can be found in MyComputer->Properties->Hardware->Device Manager->Ports

This COM port assignment will be needed in the next step.

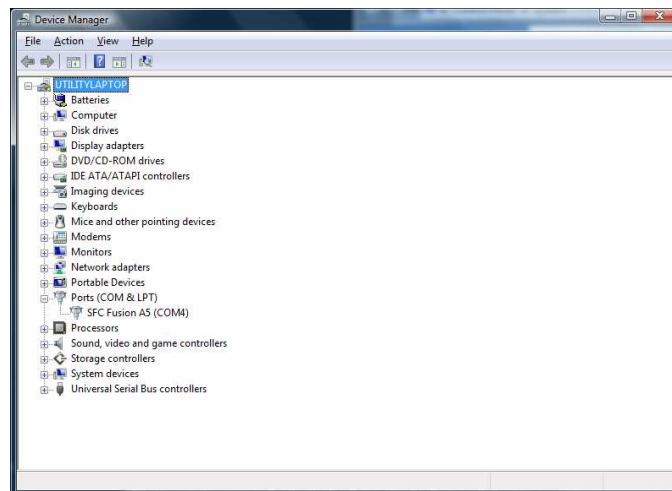

Figure 3.41

Should it be necessary to uninstall or re-install the USB interface for the A5 device, you may perform those operations by right-clicking on the SFC Fusion entry under Ports and follow the indicated steps.

Configuring the CIC driver interface in ChemStation

As previously mentioned, Agilent ChemStation provides an interface for installing devices and drivers into the Chemstation. This driver interface is referred to as Common Instrument Control or CIC for short. This is a standard mechanism to reliably add control of third party drivers. With the CIC interface, the Fusion A5 device can load, save and print method setpoints within the normal method framework. Additionally, the ready/not ready status of the A5 is monitored as part of the normal run/sequence processing.

To install the CIC interface, or verify its presence in Chemstation, we use the Chemstation's Configuration Editor. The configuration editor can be accessed via the Start menu. Navigate to Programs, Agilent ChemStation, Configuration editor.

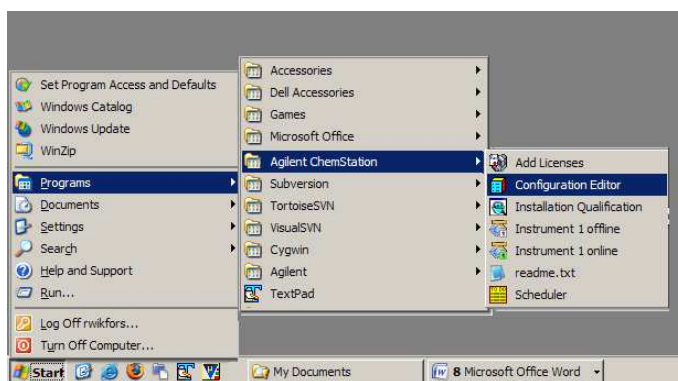

Figure 3.42

The configuration editor will display the current driver status for the installed instrument. An example of this is shown below. Normally, the LC system is selected (3D when using a DAD), with an address for communicating with the HPLC stack. If these HPLC entries are not present, please consult Chemstation documentation for an initial configuration.

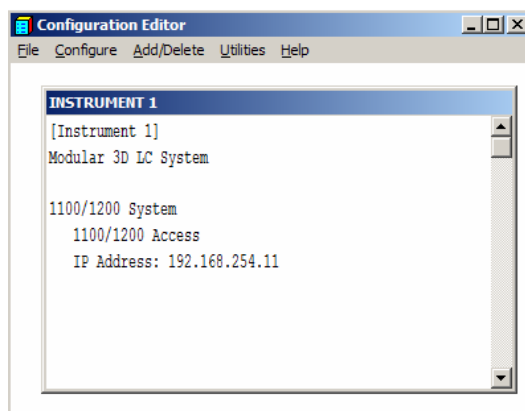

Figure 3.43

To add or edit the configuration of this instrument, select Configure - Instrument from the menu bar on the upper left part of the editor window. It will bring up a pop up window similar to below.

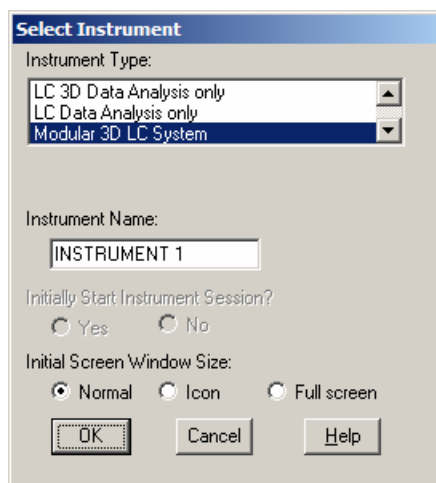

Figure 3.44

From this window, we can specify the proper instrument type. This would include Modular LC system for VWD based systems, Modular 3D LC system for systems with a DAD, Modular LC/MS system, when operating with a mass spectrometer.

Data Analysis only systems are inappropriate for instrument control and should not be selected.

The currently selected modules for this instrument now show up in the following window. Our task is to scroll in the Modules window and select the Common Instr. Ctrl's Access Point.

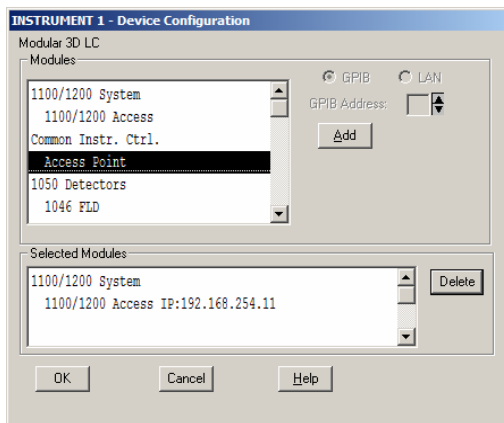

Figure 3.45

Pressing add will provide an entry point for additional module (like the A5) in chemstation.

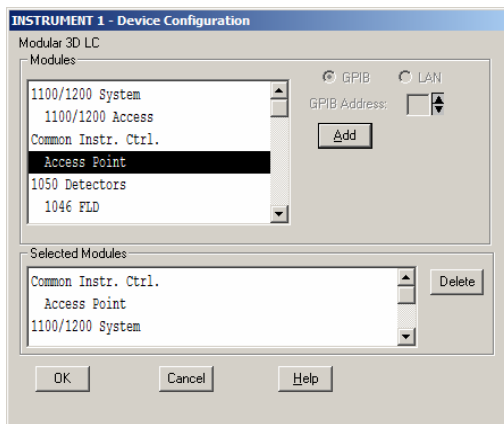

Figure 3.46

Pressing ok will add the CIC interface to ChemStation and show the current ChemStation configuration. It must include the CIC access point and the 1100/1200 system LAN

interface. Additionally, any mass spectrometer systems will have entries for the specific mass spectrometer and its associated address.

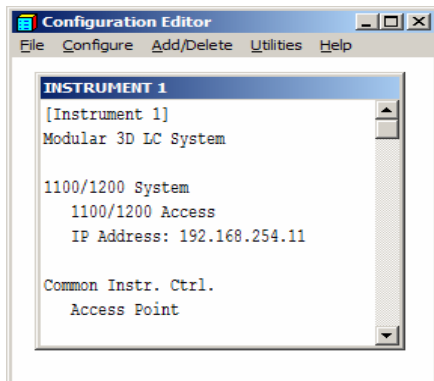

Figure 3.47

Select File and Save from the menu bar to save these modifications to the Chemstation configuration.

Now, start up an online copy of the Chemstation. Starting the online copy, or selecting Configure CIC devices from the Chemstation Instrument menu will allow the selection and configuration of the Fusion A5 system.

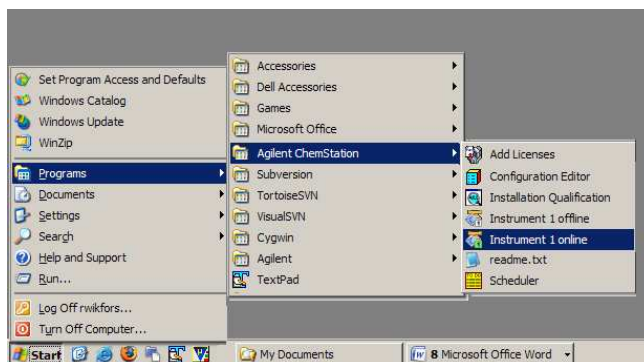

Figure 3.48

As Chemstation starts, and progresses to instrument initialization, it will recognize that a CIC device has not been installed. Chemstation will then prompt for a device with the following dialog. The device list shown is just an example and does not necessarily match the devices currently installed on the target system.

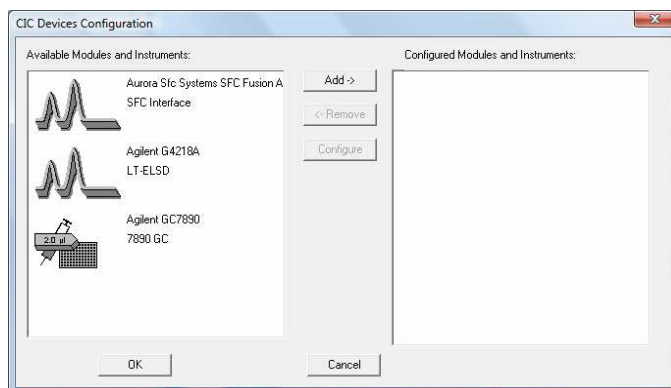

Figure 3.49

At this point, select the Fusion entry on the left panel and press the ADD button. This will create an appropriate entry on the right panel.

On occasion, the CIC window may not have focus. When this happens, you cannot click on the window to do anything. This condition can be remedied by pressing ALT-Tab (simultaneously) on the keyboard until this window receives focus.

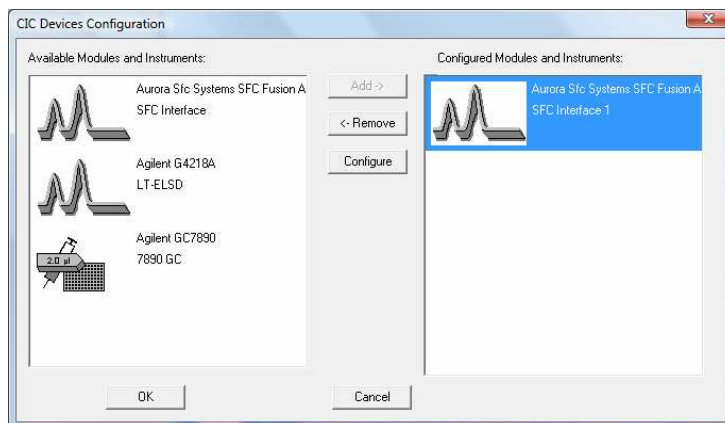

Figure 3.50

The .Fusion devices COM port can be assigned by selecting the device entry in the right panel and then pressing the Configure button. This will bring up the dialog below where you need to enter the COM port address for the device as shown in Device Manager.

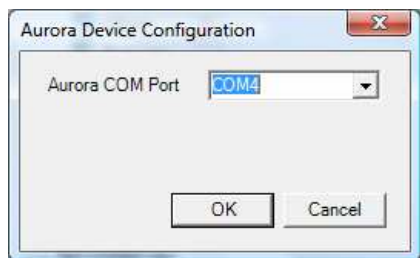

Figure 3.51

The correctly configured device will display the COM port selection in the last line of the device description in the right panel.

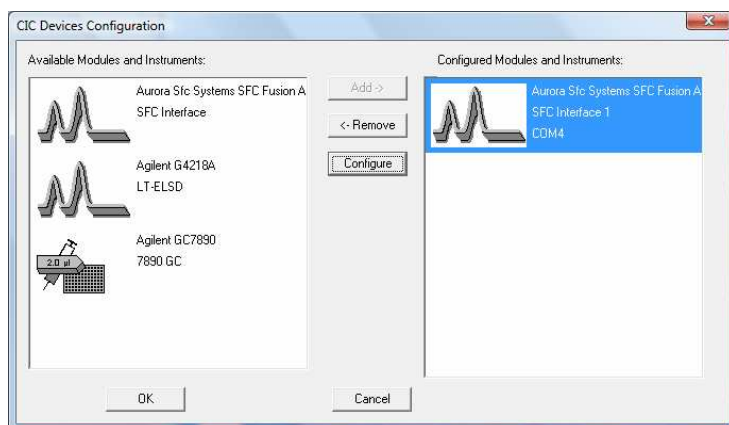

Figure 3.52

Chapter 4

Operating the SFC Fusion A5

Powering on the Module

Before operating the A5 module, it must be powered on. This is accomplished by depressing the top of the rocker-type Power switch located on the upper right rear of the module. Once the button is pressed, the A5 module will respond by entering its power up sequence. The power button of the A5 unit must remain accessible to the user at all times. Never arrange equipment so that the switch cannot be accessed.

Warning	The power switch of the A5 unit must remain accessible to the user at all times. Never arrange equipment so that the switch cannot be accessed.
----------------	---

Power Up Sequence and Operational Control States

Power up Sequence

When Power is applied to the A5 module, a series of events is initiated. The order of these events is designed to safely initialize and test individual component functionality. The module power up sequence executes the following steps:

- 1) Power is automatically applied to the processor and the two module fans
- 2) The processor initializes:
 - a. Any temporary configuration or calibration data that has not been stored in flash memory is lost
 - b. A checksum validation is made of data stored in flash memory
 - c. A self test is run to test power supply voltage levels and sensor readings for in-range values
 - d. Stored calibration and configuration data are downloaded to RAM.
 - e. The event logbook is updated
- 3) The booster pump drive is rotated searching for its index pulse.
- 4) Index pulses are tested for module fans and the coolant pump
- 5) The BPR is homed to its fully open (depressurized) position
- 6) If installed, the wash pump is rotated to its index pulse

At the completion of a successful power up sequence, the processor places the A5 module in the OFF operational state described in the next section. If an error is encountered and unresolved after multiple attempts, the module is placed into the ERROR state and a notation is stored in the event log.

Operational Control States

The SFC Fusion A5 module has three defined operational control states: OFF, STANDBY and ON. The three states are controlled by the user by selecting the A5 Control option from either the Chemstation SFC Fusion icon, by pressing various icons of the CHemstation GUI or from the Aurora A5 Diagnostic Program status tab.

Some components of the A5 module are not governed by the three described states but are continuously on. These include:

- The processor
 - continuously records and transmits sensor data to the host control system
 - handles status and command requests from the host controller
 - monitors sensors for safety related parameters
 - updates the event log
- Pressure and temperature sensors are continuously powered and sensed
- Coolant and Electronics bay fans are continuously powered
- The Wash pump is activated by contact closure of the ALS independent of the A5 control state

The OFF State

The OFF state is characterized as follows:

- The CO2 Supply Valve is closed (unpowered)
- The Booster pump drive is unpowered
- The BRP drive is unpowered
- The BRP heater is unpowered
- The chiller is unpowered
- The secondary cooling circuit pump is unpowered

The OFF state is always entered after a successful power up sequence. It can also be entered by direct user selection of the ‘off’ radio button in the control window; by a timeout from the STANDBY state or by pressing the OFF button of the Chemstation graphical user interface twice in succession.

When the A5 Module is in the OFF state, the top “power” status light is solidly lit and the bottom “ready” status light is off.

The STANDBY State

The STANDBY state is characterized as follows:

- The CO2 Supply Valve is closed (unpowered)
- The Booster pump drive is unpowered
- The BRP drive is powered.

- The BRP heater is powered
- The chiller is powered
- The secondary cooling circuit pump is powered

The STANDBY state can also be entered by direct user selection of the ‘standby’ radio button in the control window; or by pressing the power button associated with the SFC icon of the GUI; or by pressing the OFF button of the Chemstation graphical user interface once while the system is running.

When the STANDBY state is entered from the OFF state, the BPR must be homed. Once this is accomplished, the BPR drive is active but in a hold state.

When the A5 Module is in the STANDBY state, the two status lights flash in and alternating pattern. The STANDBY state will remain active for a period of up to three hours. If no user initiated action is taken to change or renew the state within this time period a timeout occurs and processor automatically enters the OFF state.

The ON State

The ON state is characterized as follows:

- The CO2 Supply Valve is open (powered)
- The Booster pump drive is powered and begins pumping CO2 to the pumps pressure target
- The BRP drive is powered and the BRP begins the process of regulating to its setpoint.
- The BRP heater is powered
- The chiller is powered
- The secondary cooling circuit pump is powered

The ON state can also be entered by direct user selection of the ‘ON’ radio button in the control window; or by pressing the power button associated with the SFC icon of the GUI; or by pressing the ON button of the Chemstation graphical user interface.

When the A5 Module is in the ON state, the top status light is continuously lit. The bottom status light becomes lit when the system reaches a “ready” state indicating that backpressure and booster pump pressure are under control and stabilized within their control band.

Modules which start from the OFF state generally first must perform an initialization routine before moving to ON. In the case of the A5 module, initialization causes the BPR first to home then move to a default initialization position. The booster pump will delay operation until the chiller passes below a threshold temperature value.

Controlling the A5 through the Agilent Chemstation™

User Interface Familiarization

Operating controls for the SFC Fusion A5 are provided within the Chemstation user interface. These controls exist within the Method and Run control view.

Should the chemstation startup in a data analysis window, you can move to the instrument control/method view by pressing the bar on the lower left or by selecting the appropriate entry in the View menu.

Inside Method and Run Control view, there are a number of operational items for the SFC Fusion™ A5

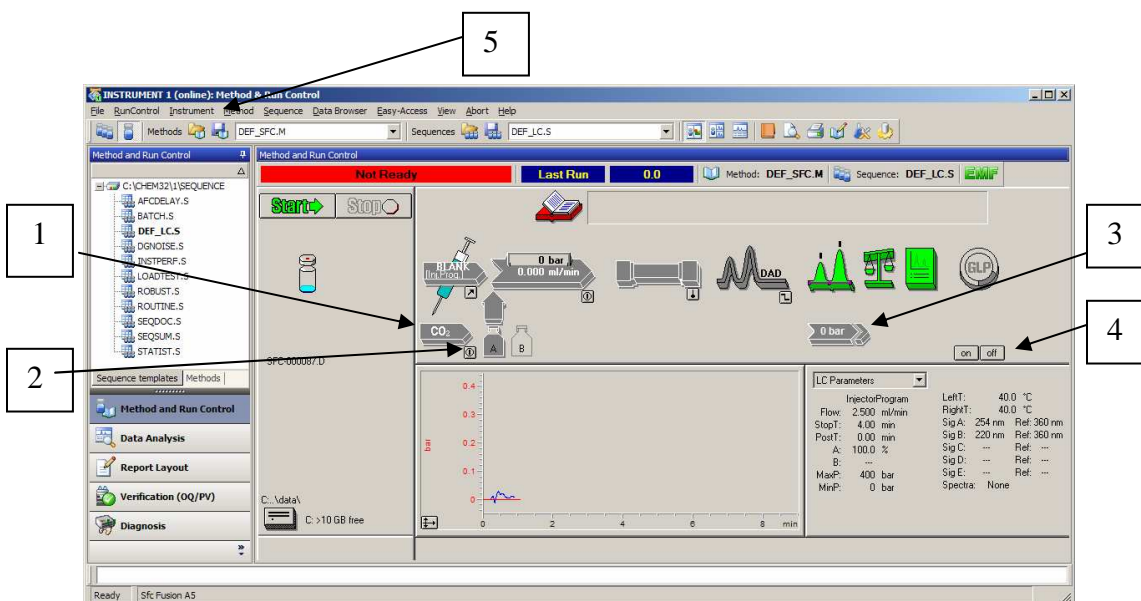



Figure 4.1
Graphical Icons used to control the A5 Module

- [1] Iconic representation for the Booster
- [2] On/Off/Standby button controlling the Fusion A5 device only.
- [3] Iconic representation of the BPR with a textual display of actual back pressure
- [4] On/Off/Standby button icons controlling all modules of the system
- [5] The Instrument menu item

The four graphical icons provide the primary control interface for the Fusion A5. Additionally, equivalents to these elements exist under the instrument menu in menu bar [5]. Other icons of the graphical user interface, retain the exact behavior they had

when running Chemstation in the HPLC mode. For this reason, users already familiar with the Chemstation have a very shallow learning curve to begin using SFC.

Exploring the A5 module Graphical User Interface (GUI)

Right clicking either of the icons  or  above displays an identical drop-down menu where:

- **Setup Aurora ...** opens the method parameter edit window
- **Inj Wash 30 Sec** runs the Wash Pump for 30 seconds as a priming step
- **Control...** opens the Control status window
- **Not Ready Reasons** opens a window which enumerates the not ready conditions of the device

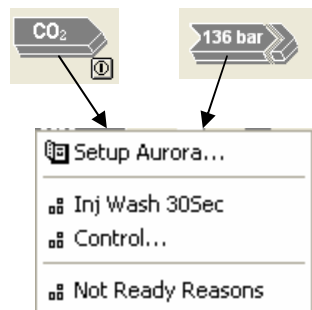



Figure 4.2
A5 Control Menu

Setting the Control State

The three control states discussed earlier [ON, OFF and STANDBY] can be directly accessed by selecting the **Control ...** menu item. This displays the Control mode window that allows users to set the current mode. In addition, a Depressurize checkbox in the window becomes active when either STANDBY or OFF is selected. Checking this box causes the BPR to home, releasing the CO2 pressure, when the window is closed by pressing OK.

Operation of the booster and BPR are tied to the same control state, so selecting the window from either icon affects both components. Selecting the On or Standby radio buttons in turn without depressurizing has an identical effect to repeatedly pressing icon  above. It alternately toggles the A5 module between ON and STANDBY.

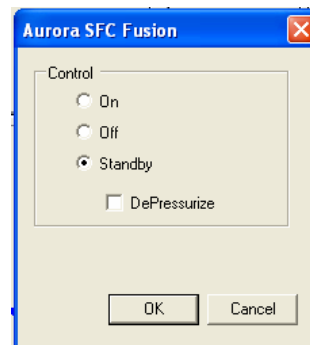

Figure 4.3
A5 Control States

Editing A5 Method Parameters

Selecting **Setup Aurora ...** displays the A5 method parameter window.

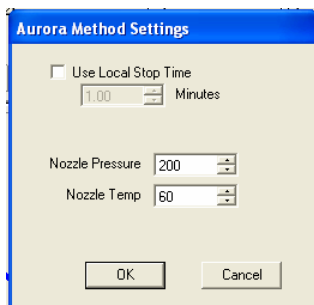

Figure 4.4
A5 Method Parameters

The most critical setpoint of the A5 device is the Nozzle Pressure parameter. This setpoint controls the SFC mobile phase back pressure regulated by the BPR in the range from 100 to 350 bar. Well controlled backpressure in SFC maintains the CO₂ at liquid-like densities necessary to keep all mobile phase components in a single phase. Optical detectors benefit greatly from the ultra low-noise BPR of the A5 module, which High sensitivity analytical methods generally require BPR pressure settings between 140 and 200 bar. The lower setpoint range is convenient when split-flow is required [e.g for a mass spec or ELSD interface] to

limit the volume flowing into the split stream.

Other parameters of this window include Nozzle Temp which sets the BPR temperature in the range of 40 to 70C, and a Local Stop Time which allows the A5 to have its own run duration during a method. Except in rare circumstances, the default values shown should be used. Pressing OK exits the edit window and immediately sends the revised parameters to the A5.

Changing the pressure setpoint while the A5 unit is ON will change both the BPR and booster pump demands. The A5 module may take some time to adjust to the new back pressure and stabilize. During this time, icons **1** and/or **3** will be displayed as yellow indicating the “not ready” condition. When the icons become “ready” the icon will turn green.

Turning the SFC System on and off

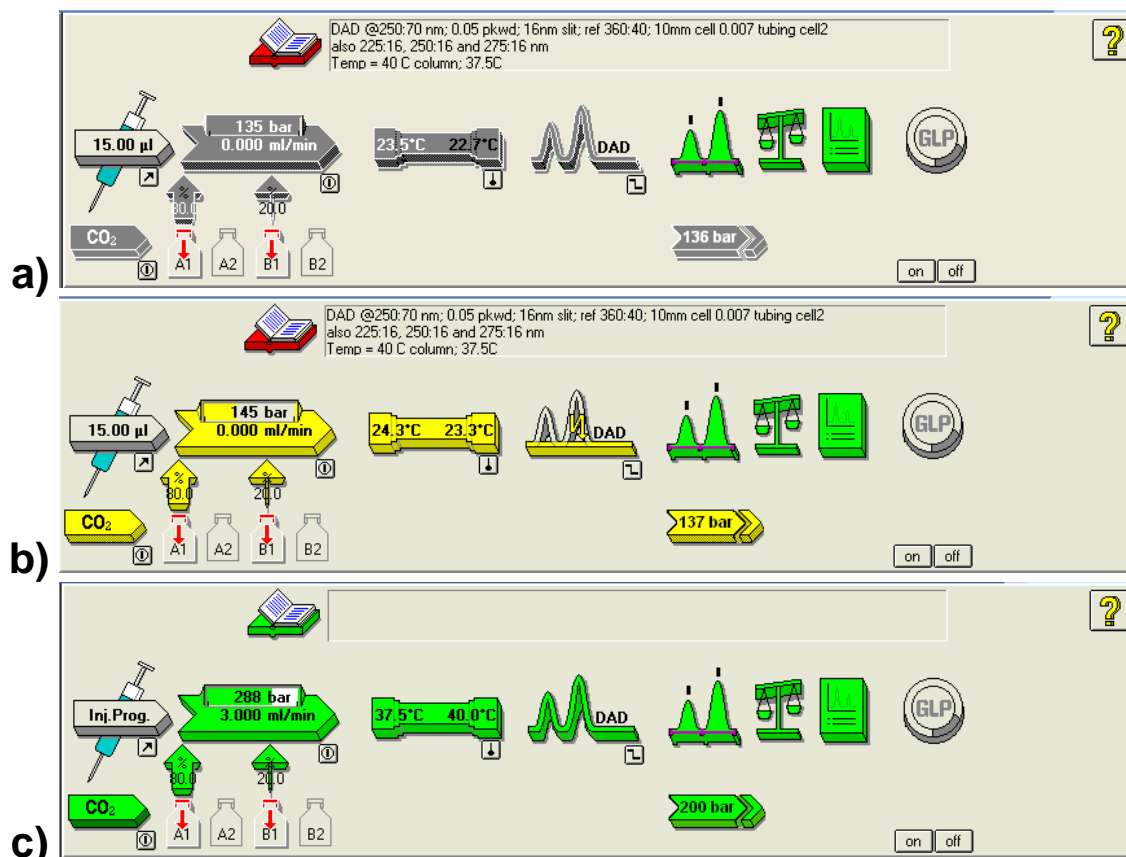

Figure 4.5
Chemstation GUI control panels showing modules in
a) OFF/STANDBY state; b) ON/not ready state
and c) ON/ready state

If the SFC system is in the OFF or STANDBY states when the Chemstation is started, icons will appear gray as in Figure __ a). From this state, the easiest means of starting up the entire SFC system is by depressing the system On button [4]. This is the equivalent of moving all modules to the ON state at the same time.

The Chemstation responds by activating all modules. Some modules may first perform and initialization routine. Starting at initialization until each component in the SFC system reaches a “ready” condition, icons are shaded yellow to indicate a not ready condition. When the ready condition is achieved, the icons turn green. Figure 4.5 shows views of the GUI control pane in the a) OFF/STANDBY state ; b) not ready and c) ready conditions of the ON state. Note that the Autosampler icon in the three figures does not participate in visual status cues. The Autosampler is considered to be always in the ON/ready control state unless an exception is indicated [e.g. door open]. A Red icon indicates an error state has been detected.

Starting the Chemstation does not change the current operational control state of the SFC system modules. Components that were left in the ON state when Chemstation closed, remain ON outside of Workstation control and also when the Workstation software restarts. The SFC Fusion A5 driver conforms to this standard. The one exception is that if the Chemstation is exited with the A5 unit in STANDBY, it will change state to OFF after the idle timeout period, whether under Chemstation control or not.

It is a good practice to place all pumps, including the A5, into the STANDBY or OFF state before exiting the Chemstation. This assures that all pumping of fluids is performed under the supervision of the workstation rather than simply the individual modules.

Depressing the system OFF button 4 moves all modules to the standby state. In some cases, users may prefer to leave the column oven and detector in the ON state during shutdown. In these cases the A5 and the binary pump can be turned off individually by depressing their individual ON/OFF buttons.

CAUTION

Set all system pumps, including the A5 unit, to OFF or STANDBY before exiting the Chemstation. Pumps left in the ON state are unsupervised by the workstation. This may result in unsafe operation.

Starting and Stopping the A5 Module

The A5 module can be controlled individually via button 2 of the GUI. Pressing the button toggles the state between ON and STANDBY. The A5 booster is intended to operate in coordination with the binary pump during normal operation [i.e. both module ON]. It is not recommended to place the binary pump in the ON state without activating the A5 module since the binary pump will not be able to pump CO₂ properly. Table ___ shows pump responses to the four possible control stat combinations. In general, both pumps should be started and stopped at the same time.

**Table 4.1
Combined A5 and Binary Control State Responses.**

Response to Control State Combinations of the A5 and Binary Pump Modules		
A5 State	Binary State	Response
OFF	OFF	Both Pumps Idle
OFF	ON	Binary pump attempts to pump both CO2 and modifier, but effectively pumps only modifier. Column fills with pure modifier. Back pressure approaches last controlled setpoint, but is not actively controlled. This is not a recommended control state.
ON	OFF	Booster delivers CO2 to Backpressure setpoint then slows or stops to maintain pressure. Back pressure is actively controlled. The system is not flow rate controlled.
ON	ON	Normal Operation. Booster provides binary pump with preconditioned CO2 based on flow demand. Binary pump delivers controlled CO2 and modifier mixtures to the flow system. Back pressure actively controlled.

CAUTION

Do not start the binary pump without starting the A5 unit. This can cause the flow system and column to fill with modifier without active backpressure regulation. Back pressure will be limited near the last active setpoint.

Controlling the Wash Pump

Some A5 modules include a wash pump installed in the BPR drawer of the module. The wash pump is intended to supply wash solvent to Agilent 1100 and 1200 standard and wellplate autosamplers. As part of the installation, the wash pump inlet port is plumbed to a supply reservoir of wash solvent and the outlet is plumbed to the inlet of the autosampler metering pump. The wash pump is controlled by contact 2 of the BCD interface card installed into the autosampler. While the contact is closed, the wash pump operates continuously, opening the contact halts operation. The default state of contact 2 is always open.

The wash pump can be activated manually for 30 second intervals by selecting the **Inj Wash 30 Sec** menu item of the booster or BPR control menus. This initiates the pump and halts operation automatically and is the safest means of operation.

Some priming operations may require longer periods. The pump can be activated for an indefinite period by accessing the **Contacts ...** menu of the autosampler and closing contact 2. The wash pump should not be left unattended in this state. It will continue operating even after the reservoir empties and may damage the pump seal. In addition, the waste reservoir may be overfilled. When the desired amount of priming has occurred return Contact 2 to the open state.

Warning

Never leave the system unattended with the wash pump operating by manual contact closure. This can result in damage to pump seals as well as waste reservoir overflow.

The wash pump can also be activated as part on an injector program using the CONTACT command. An example of needle rinsing in an injector program is found in DEF_SFC.mth. Generally the program includes a WAIT step between closing and opening the contact to give a timed rinse.

Before operating the wash pump manually or as part of an injector program, users must assure the wash solvent has a controlled waste path. Generally, the needle must be seated in the needle seat. Some autosamplers provide wash stations for the needle that may be appropriate. Never operate the wash pump with the needle in the raised position or inserted into a vial. This will generate a leak condition and halt the system.

Warning

Never operate the wash pump with the needle in the raised position or inserted into a vial. This can cause a leak condition and halt the system.

Viewing A5 Charting Functions

A powerful feature of the Chemstation is the ability to chart various real time signals such as detector signals, binary pump pressure and flow, etc. The A5 driver supports real time charting of a variety of internal signals listed in the appendix. By default, A5 backpressure and booster pressure are immediately available for charting. This is accomplished by selecting the CHANGE button in the lower right of the expanded charting view which produces the Edit Plot Signal window in Figure 4.6. Moving one or more of the *SFCx* signals to the Selected Signals pane initiates charting.

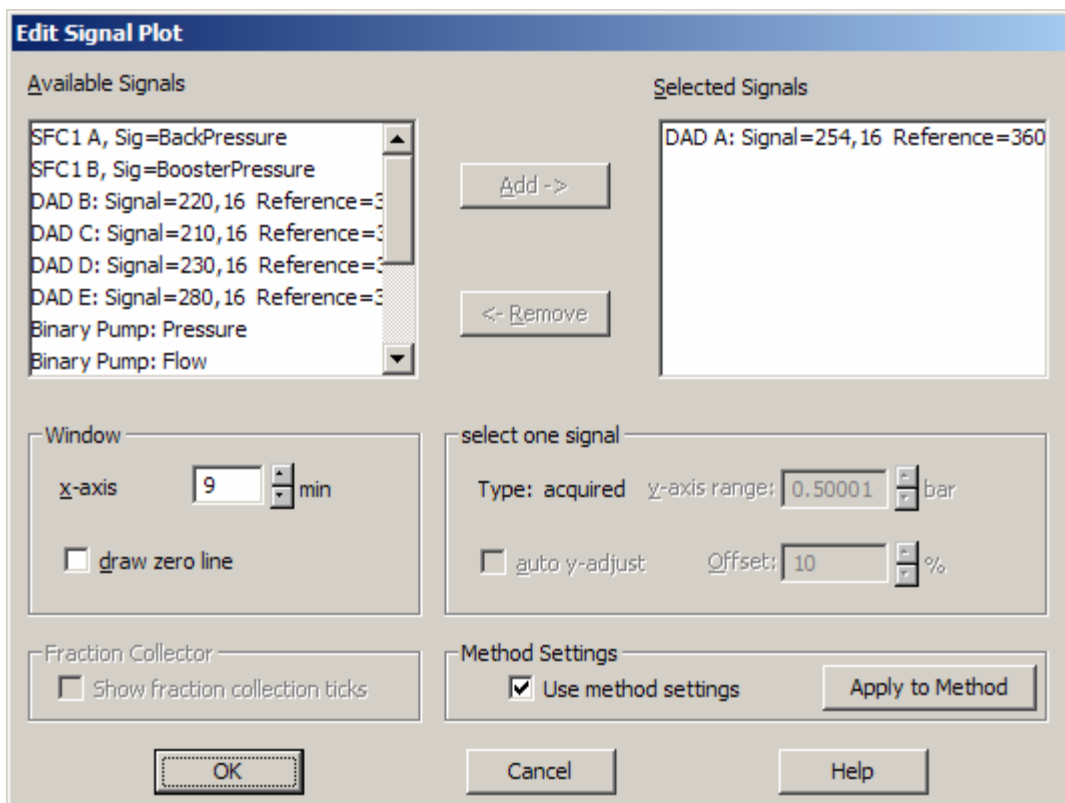

Figure 4.6
Edit Signal Plot Window

Running a method on the SFC system

Loading the SFC_Def analysis method

As part of software installation, a write protected method named DEF_SFC has been loaded into the Chemstation Methods directory. The method contains parameters used to evaluate noise performance of the SFC Fusion enhanced system. As is the standard for DEF_XXX methods, the binary pump flowrate has been set to zero so the pump will stop pumping when the method is loaded. To load the methods, used the menu bar and select File | Load | Method then select DEF_SFC from the list.

The DEF_SFC method uses many of the low noise optimizing techniques described in later chapters. In particular,

Adjusting the method for use

A few adjustments must be made for use. From the Control GUI:

- 1) Adjust the binary pump flow rate to 3 mL/min.

- 2) If a flow splitter has been installed down stream of the UV Detector, adjust the BPR Nozzle pressure to 140 bar.
- 3) If thermal optimization has been performed, set the left column oven heater to the optimum conditioning temperature
- 4) If a VWD is used, set the wavelength to 254 nm and peakwidth of 0.05 min.
- 5) Save the method as SFC Checkout.

Running the Checkout Method

STEP 1: Install a test column into the system. See instruction for changing columns in the maintenance chapter.

STEP 2: Turn the SFC system ON by pressing button on the Control GUI.

STEP 3: Load SFC_Checkout.mth

STEP 4: Open the modifier prime valve and prime the modifier until a bubble-free stream is observed in the transparent supply tube between the degasser and the pump for at least 30 seconds. Close the prime valve

STEP 5: Allow the system to stabilize several minutes until the UV detector signal has drift of < 1 mAU/min [typically about 10 minutes]

STEP 6: Set the injection mode to single sample

STEP 7: Set the data directory to SFC Checkout

Several types of injection can be performed including no physical injection [baseline evaluation]; blank injection, and sample injection. Each type begins with Step 8 as a continuation of the prior steps.

Baseline Evaluation

STEP 8: Clear the Vial field

STEP 9: Label the data file Baseline_ xxxx

STEP 10: Press START

Response: The method first zeros the DAD and then immediately starts into one minute of data collection. No injection is made; the valve does not turn. The data is saved in the data file and can be reanalyzed using noise analysis tools to determine baseline noise. At the method data rate, [5Hz; pkwd 0.05min] time

segments of approximately 0.2 to 0.3 minutes should be sampled to cover the 6-sigma time at the base of a normal SFC peak.

Blank Injection

STEP 8: Insert a vial containing pure methanol into the autosampler

STEP 9: Set the Vial field to the position **if** the blank vial

STEP 10 Label the data file Blank_ xxxx

STEP 11: Adjust the binary pump run time to 5 minutes

STEP 12: Adjust the absorbance range of the signal to about 20 mAU full scale

STEP 13: Press START

Response: The method first zeros the DAD and then uses the injector program to fill, and inject 5uL of blank. Data acquisition starts with the injection. The data will show the effect of the solvent alone on the baseline.

For this isocratic method, the baseline will return quickly to the initial status after the solvent front. For some gradient methods where the composition changes with time the baseline may slope up or down at various times and more or less at different wavelengths. The data file can be reanalyzed using noise analysis tools to determine baseline noise. It can also be subtracted from sample runs to eliminate spurious signals caused by the solvent composition.

Sample Injection

STEP 8: Insert a vial containing sample into the autosampler. [The selected sample should elute at the current conditions within the 5 minute period.]

STEP 9: Set the Vial field to the position **if** the sample vial

STEP 10 Label the data file Sample_ xxxx

STEP 11: Adjust the binary pump run time to 5 minutes

STEP 12: Adjust the absorbance range of the signal to about 20 mAU full scale

STEP 13: Press START

Response: The method behaves similar to the blank run. The data file can be reanalyzed using noise analysis tools to determine baseline noise. The user may also

subtract the blank run to eliminate spurious signals caused by the solvent composition.

Shutting Down the SFC

The manner of shutting down the SFC depends on the users needs for rapidly equilibrating the system on the next startup and how certain the timing of that startup. If the system will be shutdown for a while, it is probably best to shutdown all components including the DAD and column oven. These latter components tend to take more time to reach their most stable operating states than other components in the system. The user should always shut down both the A5 and the binary pump if the system is to be idle for a long time.

Partial Shutdown

Leaving the system pressurized

If the system is to be shut down for less than 2 hours a partial pressurized shutdown is preferred. Press the control buttons [e.g. button] to move the A5 and binary pump states to STANDBY. In this case, the system will remain pressurized and slowly bleed pressure via the nozzle. A residual pressure will remain in the system when the nozzle actually fully closes at lower pressure. The booster will remain chilled and much of the startup CO₂ will be preserved. The user should be aware that the system is pressurized and not attempt maintenance under this condition.

Warning

Setting the pump to STANDBY does not depressurize the system. Do not attempt to loosen fittings or perform maintenance under this condition. Serious skin and eye injuries can occur as the result of sudden release of CO₂ in the liquid or supercritical state. Gloves and eye protection should always be worn when operating or maintaining the A5 unit.

The detector and column oven are left in the on state to maintain their readiness. The user may elect to exit the Chemstation in this state and should answer NO to the “Shutdown Lamps...” query that appears during shutdown. Restarting the Chemstation will bring the system to this same state. If more than two hours in STANDBY elapse, then the A5 enters the OFF state and pressure may be lost at a more rapid rate.

Depressurizing the system

When maintenance is required on the SFC system, such as replacing the column, the system should be depressurized. Again, it is not necessary to shut down all modules, but only the pumps and other devices to be maintained. To depressurize the system, first

stop the A5 and the binary pump. Next open the **Control...** menu of the A5 booster [the standby state will be selected] and check the depressurize box. Then press OK.

NOTICE

If the A5 unit itself is to be serviced, select the OFF state of the Control window. This will shut off the BPR heater and booster chiller and allow them to move toward ambient temperature.

This will cause the BPR to home and fully open the CO2 path to depressurize. The A5 unit contains approximately 30 mL of stored CO2. This amount of CO2 should be vented properly. It will take several minutes to effectively drain. The user should allow the system to drain at least below 40 bar before cracking any fittings. At that point the CO2 will be in the vapor state and represent a small expanded volume. However, users must never inhale vapor directly from a cracked fitting. The concentration of CO2 emerging from a flow line even at low pressures can be toxic or even lethal.

Warning

Never inhale vapor issuing from an SFC flow line. Exposure to concentrations of CO2 over 5% in air can be lethal. Always keep tubes directed away your face. CO2 is ubiquitous in the atmosphere, but at high levels should be treated with the same care as handling other toxic chemicals. Always wear gloves and eye protection for safety. Avoid inhaling.

Alternatively, if the column oven contains a column switching valve, one path may be jumpered without a column. The reduced restriction will allow the system to depressurize much faster. Further, the isolated column can be exchanged immediately since the contained volume is CO2 is very small.

Warning

The A5 unit contains approximately 30 mL of liquid CO2. The CO2 must be vented properly since the expanded volume will allow local concentrations exceeding the OSHA PEL. Always allow the system to depressurize to below 40 bar before cracking any fittings. Always keep fittings directed away.

Full Shutdown

The SFC system can be fully shut down easily in two ways:

- 1) Press the Off button of icon .
 - a. One press for STANDBY
 - b. Two presses for OFF
- 2) Close the Chemstation.
 - a. Answer 'Yes' to the "Shutdown Lamps..." query that appears.

Both of these actions leave the SFC system pressurized. To depressurize the system refer to the discussion under Partial Shutdown.

Chapter 5

Maintaining the SFC Fusion A5

Inspection and Preventative Maintenance Intervals

Inspection and maintenance of the A5 system are critical elements of long term reliability and performance of the system. Maintenance falls into two categories, preventative and corrective. Preventative maintenance intervals can vary based on the system use. The intervals offered in this section are for systems with average use of approximately 30 hours per week. Infrequently used systems may extend these intervals, while heavily used systems may require more frequent preventative maintenance. Most service can be performed directly by the user or in-house maintenance technicians.

Daily Inspection and Maintenance

- Verify power and signal cables are firmly connected and not under strain
- Inspect all user serviceable high pressure tubes and transfer lines for crimping or very tight bends. Replace as necessary.
- Wipe up any visible liquid spills or condensation on or near instrument.
- Verify that all covers are securely fastened to the frame
- Inspect all reservoirs to insure an adequate solvent supply
- Prime wash pump and modifier pumps. Check that the purge valve reseals without leaking
- Empty all waste containers
- Check that exhaust line is attached to ventilation system and system is drawing
- If an inlet step down regulator is used with a gas supply system, check inlet pressure is between 40 and 70 bar.
- Check the integrity of the SFC Flow path. [i.e. that column, flow cell etc have not been removed]
- With system running, visually inspect unions and tees for leaks. Run diagnostic leak test for added sensitivity.
- Check CO2 air monitor, if available, for suitable exposure level [< 5000 ppm CO2]

Every 3 months

- Run nozzle diagnostic test
- Run system leak test
- Evaluate system calibration
- Check chiller efficiency curve

- If CO2 cylinders are used as supply, change cylinder seal [appx every 10 cylinders] with next tank change
- Remove visible dust accumulation in the area of the module

Annually

- Have service evaluation and maintenance by a Aurora SFC qualified service technician
 - Perform 3 month maintenance
 - Change booster and binary Pump A (CO2) piston seals
 - Inspect booster and CO2 metering pump check valve frits for seal wear; change frit or entire CV as necessary
 - Change coolant
 - Clean fan access paths
 - Upgrade firmware with any recommended safety or performance enhancements
 - Change modifier purge check valve
 - Change injection valve 3-groove rotor
 - Inspect high pressure flow cell
 - Inspect leak sensor function

As Needed [Corrective]

- Change booster and CO2 Pump check valves
- Change high pressure transfer lines with metal ferrules or PEEK end fittings after 10-20 reseals or when leaking
- Change Booster piston [rare]
- Change CO2 inlet filter
- Exchange BPR head [rare]

General Maintenance procedures

Booster Drawer

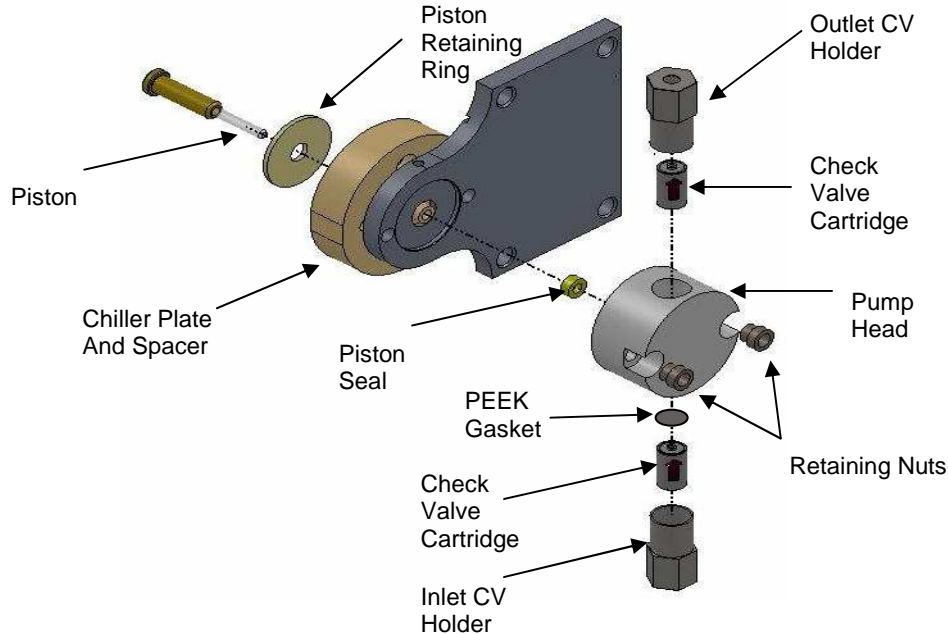

Figure 5.1
Exploded view of Booster Components

Procedure 1: Removing and Replacing the vapor shield (not shown)

Most maintenance procedures require removal of the Vapor shield to access the underlying pump unit..

You will need:

- A 3/16" hex drive wrench

Removal Procedure:

1. Set the Control state to OFF on the A5 module
2. Wait for the chiller temperature to approach room temperature. This will prevent significant condensation on the chiller assembly and pump head.
3. Turn the power OFF on the A5 module. (Remove Power cord?)
4. Remove the front cover of the A5 unit by pulling gently at the upper left and right indents to the rear of the cover. The cover will release from its magnetic catch. Lift the cover upward to clear the two mounting pins at

- the base. Set the cover aside. [Note: the 3/16" hex wrench used to remove the vapor shield and pump head is stored inside the removable front cover]
5. While holding the vapor shield with one hand, use the 3/16" hex wrench to loosen the four cap screws attaching each corner of the shield until they each disengage from the front panel. The screws are captured in the shield; do not try to remove them completely.
 6. Remove the shield and store it in a safe location. Do not use the shield as a container for disassembled parts. This will scratch the plastic surface and impair visibility of the pump head during operation.

Replacement Procedure

1. Locate the vapor shield approximately over the mounting holes in the booster drawer front panel.
2. Engage each screw approximately one turn.
3. Inspect the border of the vapor shield to make sure it is in sealing contact with the foam seal of the drawer face. Adjust as necessary.
4. Tighten the mounting screws to insure at least 50% deflection of the foam seal by the shield.
5. Replace the front cover by aligning the two base mounting pins and tilting forward to engage the magnetic catches.

Procedure 2: Replacing Booster Pump check valves

You will need:

- Tools necessary to remove the vapor barrier
- A 1/4" open end wrench
- A 9/16" open end wrench
- One or two Check valve cartridges

Procedure:

1. Remove the vapor shield
2. With the 1/4" and 9/16" wrenches loosen and remove the inlet or outlet capillary tube
3. With the 9/16" wrench loosen and remove the desired check valve holder. The check valve may or may not be extracted with the holder.
4. [Inlet CV only] The inlet check valve assembly includes a PEEK gasket. Set this gasket aside for reuse.
5. Remove the defective check valve cartridge.
6. Insert the new check valve cartridge into the holder oriented correctly for the direction of flow [arrow up] The inlet check valve will be

inserted with the non-filter end of the cartridge showing. The outlet check valve will be inserted with the filter end of the cartridge showing.

CAUTION

The orientation of the CV cartridge is critical. An arrow on the side of the cartridge indicates the direction of flow. Make sure the cartridge is installed to allow flow in the proper direction when installed into the pump head.

7. [Inlet CV only] Replace the PEEK gasket on the top of the inlet check valve cartridge with the flat side of the gasket facing the cartridge.
8. Insert the CV holder into the pump head and tighten with a 9/16" wrench.
9. Refasten the inlet or outlet capillary line holding the CV holder with a 9/16" wrench and tightening with the 1/4" wrench to seal.
10. Replace the vapor shield

Procedure 3: Removing, Cleaning and Replacing the Pump head and Replacing the Piston seal

Notes:

Each time the booster pump head is removed, the piston seal should be exchanged. This is because the seal surface may be easily scratched or distorted during the removal process. For this reason the procedures are bundled. Cleaning the pump head is optional after visual inspection. Sealing surfaces of the pump head are critical to successful operation. Never use metal tools or paper toweling to wipe, probe or contact these surfaces.

You will need:

- A 1/4" open end wrench
- A 9/16" open end wrench
- A 3/16" hex drive wrench
- A new piston seal
- seal insertion/removal tool
- Ultrasonic bath
- Isopropanol
- Deionized water

3A: Pump Head Removal Procedure:

1. Set the A5 Control mode to OFF

2. Wait for the pump head to reach room temperature
3. Power off the A5 module
4. Remove the vapor shield
5. With a 9/16" and 1/4" wrenches, remove the inlet line from the inlet check valve holder and the outlet line from the outlet check valve holder.
6. With the 3/16" hex drive carefully remove the two knurled nuts at the front of the pump head.

CAUTION Be careful not to break the piston when removing the pump head. Twisting the pump head can cause the piston to break.
--

7. Carefully separate the pump head from the pump. Move the pump head straight out from the pump and remove it from the piston. Be careful not to break or damage the piston. Also remove the seal from the piston if it did not stay in the pump head.
8. If the seal remains with the pump head, insert the flanged end of the seal insertion/removal tool into the seal cavity. Tilt it slightly so that flange is under the seal and pull out the seal.

CAUTION Using any other "tool" will scratch the finish.
--

3B: Pump Head Inspection and Cleaning Procedure

9. Visually inspect the piston seal cavity in the pump head. Use magnification if necessary. Remove any foreign material using a cotton swab, or equivalent, and avoid scratching the sealing surfaces. Be sure no fibers from the cleaning swab remain in the components.
10. The pump head, may be further cleaned as follows:
 - a. Remove inlet and outlet check valves
 - b. Clean with 50% isopropanol in water in an ultrasonic bath for at least 30 minutes, followed by rinsing for at least 10 minutes in 100% isopropanol. Be sure that all particles loosened by the above procedures have been removed from the components before re-assembly.
 - c. Replace the check valves
11. wipe off any residual liquid from external [non sealing] surfaces with a soft cloth such as a microfiber towel.

3C: Piston Seal Replacement Procedure

12. Sonicate or soak the new seal in isopropanol for 15 minutes to clean and provide lubrication for installing
13. Place the replacement seal on the rod-shaped end of the seal insertion/removal tool so that the spring is visible when the seal is fully

seated on the tool. Insert the tool into the pump head so that the open side of the seal enters first, facing the high-pressure cavity of the pump head. Be careful to line up the seal with the cavity while inserting. Then withdraw the tool, leaving the seal in the pump head. When you look into the pump head cavity, only the polymer portion of the seal should be visible.

3D: Pump Head Replacement Procedure:

14. Fill the pump head cavity about one third full with isopropyl alcohol.
15. Wet the piston tip with a few drops of isopropyl alcohol.
16. Holding an absorbent towel beneath the pump head assembly, line up the pump head and carefully slide it into place. Be sure that the inlet valve is on the bottom and the outlet valve is on the top. Do not force the pump head into place.
17. Finger tighten both knurled nuts into place. To tighten firmly, alternately turn nuts 1/4 turn while gently wiggling the pump head to center it.
18. Re-attach the inlet and outlet lines.

Procedure 4: Cleaning or Replacing Booster Pump Piston

Notes

In most cases, this procedure will be used only to replace a broken piston. Pumping CO₂ does not tend to leave deposits on the piston. Development of such deposits warrants examination of the CO₂ supply system and correcting the source of the deposited materials. Release of extraneous materials into the CO₂ supply system may cause contamination of the SFC system.

You will need:

- Tools for removing the vapor shield and pump head [procedures 1 and 3]
- A piston replacement kit
- A 9/64" hex drive wrench

Procedure

- 1) Remove the Vapor Shield
- 2) Remove the pump head
- 3) Clean the pump head
- 4) With a gentle rocking motion, loosen the chiller plate assembly and carefully slide it forward off the pump head mounting posts. Carefully twist the assembly out of the way.

CAUTION

Use care removing the chiller assembly from the mounting posts. The assembly is connected to a circulation pump behind the drawer panel. Do not pull the flow lines hard as this may loosen or crimp the tubes and cause the chiller to lose efficiency or cause leaks in the secondary cooler system.

- 5) Use the 9/64" hex wrench to unscrew the two cap screws attaching the spacer and very carefully remove the spacer by pulling straight back. This fully exposes the piston and retaining ring.
- 6) Remove the retaining ring by prying it out with a small blunt instrument or tweezers at the slot provided.
- 7) Grasp the metal base of the piston assembly so that you avoid exerting any side load on the sapphire rod, and remove the piston from the slot in the carrier by sliding it up.
- 8) Grasp the metal base of the replacement piston assembly, and insert it into the slot in the piston carrier until it bottoms in the slot.
- 9) Replace the retaining ring and spacer. Reattach the spacer mounting screws. If properly positioned, the spacer should be pressed into the foam wall seal.
- 10) Gently slide the chiller back onto the pump mounting posts and firmly press it onto the spacer. If properly positioned, the chiller heat exchanger should now be pressed into the foam wall seal.
- 11) Replace the piston seal
- 12) Replace the pump head
- 13) Replace the vapor shield

Replacing the CO2 Inlet Filter

- 1) Unscrew the filter closure from the filter housing.

CAUTION

Do not use a metal object such as a screwdriver or paperclip to remove the seal. Doing so can scratch the precision surface of the seat and may cause the filter to leak.

- 2) Use a seal insertion/removal tool or a non-metallic object (such as a wooden toothpick) to remove the large seal that remains in the housing
- 3) Unscrew the old filter and remove the small seal from the filter closure.
- 4) Place one of the small seals included in the replacement element kit over one of the new filters from the kit. Screw the new filter into the filter closure (finger tight).
- 5) Place one of the large seals from the replacement kit on the filter closure. Insert the filter closure into the housing and tighten.

Replacing Fuses

The power entry module of the A5 unit contains an external fuse drawer that is user serviceable.

To replace fuses:

1. Power down the unit
2. Disconnect the power cable from the power entry module
3. Depress the release lever of the fuse drawer and pull the drawer straight back to remove.
4. Replace blown fuses with 8A 250V Time Delay fuses of matching size. [A set of replacement fuses is included in the A5 ship kit]
5. Replace the fuse drawer by sliding it into the power entry module until it locks into place.

Cleaning and Decontamination

Cleaning

External surfaces of the enclosure can be wiped with a damp soft cloth to clean. More stubborn marks can be removed with a 50% isopropanol:water mixture or mild cleanser such as Soft Scrub™. The latter may also be used to remove surface paint blemishes that may result from normal use.

The vapor shield of the booster drawer should be wiped only with a very soft cloth such as a microfibre polypropylene cloth, otherwise scratching of the surface may occur. Other user accessible internal surfaces can be cleaned with a damp cloth.

Standard Decontamination

Booster Pump

The booster drawer of the A5 module contacts only pure CO₂ and generally does not require specific decontamination measures.

BPR

The BPR head contacts CO₂, modifiers and sample material. To decontaminate, rinse with 50% modifier flow at 5 mL/min for 15 minutes followed by pure CO₂ for 5 minutes.

Wash Pump

1. Drain the inlet line of old solvent.
2. Flush the inlet line and filter from a small intermediate reservoir to rinse contaminated residual fluid from the lines
3. Insert the inlet line into a fresh supply of pure solvent
4. Prime the wash for 2 minutes [four consecutive presses of the 30 second timer] to clear the remaining flow path.

Plugged BPR Decontamination

Decontamination of plugged BPR heads may require more aggressive solvents. In this case use the following procedure:

1. Depressureize the A5 unit completely.
2. Disconnect the BPR inlet and outlet tubes from the BPR drawer.
3. Attach the Inlet tube via a transfer line to waste.
4. Attach a solvent pump to the outlet tube of the BPR head
5. Prime the pump with a suitable solvent for the obstructed material.
6. Flush backwards with strong solvent at 1 mL/min for 20 minutes. Do not exceed a pressure of 400 bar.
7. If the pump cannot transfer fluid at less than 400 bar discontinue the operation and perform steps to exchange the BPR head.
8. IF the backflush is successful, rinse the BPR head with Isopropanol for 10 minutes at 1 mL/min to clear the strong solvent.
9. Reconnect the BPR inlet and outlet lines.
10. Complete the standard decontamination procedure listed above

Preparing for storage or shipping

If the A5 module needs to be stored in other than its operational location it is best to store in the original factory packaging. This packaging can also be used to reship the device to a secondary location. If the original packaging is unavailable, the unit should be stored upright and preferably covered in a plastic bag or wrap to prevent exposure to dust.





To prepare the unit for storage use the following procedure:

1. Follow the standard decontamination procedure
2. Depressurize the SFC system completely
3. Power off the unit
4. Remove the front panel
5. Disconnect the wash pump transfer line from the autosampler
6. Drain the Wash pump lines of fluid
7. Coil the lines to fit in the A5 module behind the removable front panel
8. Disconnect the Booster pump transfer line from the binary pump at the pump inlet check valve
9. Disconnect the BPR return line from the detector
10. Coil both lines to fit inside the A5 unit behind the removable front panel
11. Replace the Front panel
12. Disconnect the power cord and all signal cables from both ends of the connection.
13. Store cables and cords in a large plastic zip lock bag
14. Cover the unit with a large plastic bag

15. If the original container is available, place the unit with its left side down in the packaging. Other wise store the unit upright in the storage area.
16. If the HPLC will also be stored/shipped and will be reconfigured as an SFC system, the upgrade components may remain in the system.
17. If the two systems are to be permanently separated. Uninstall the check valves, modifier purge valve, 3 groove rotor and high pressure flow cell by reversing the install procedures of Chapter 3. Store the components along with the original software disc and any upgrades with the module.

APPENDIX

**Table A.1
A5 Consumable Parts**

Part View	P/N	Description
A5 Booster Drawer		
	00-73-1010	A5 Pump Seals; UHMWPE
	A5-26-6010	A5 Seal Extractor Tool
	00-73-2010	Check Valve Cartridge; 0.125 ball [fit all supplied Agilent and A5 CV holders]
	00-73-2160	Check Valve Holder (A5)
No photo available	A5-69-4010	A5 Pump transfer line
No photo available	A5-60-9050	CO2 Supply Line
No photo available		A5 Inlet CV gasket
No photo available		Booster Pump Piston Kit
No photo available		CO2 inlet replacement filter cup

A5 BPR Drawer		
No photo available	A5-69-4070	A5 Return transfer Line
No photo available	00-73-2060	Wash Line Check Valve
No photo available		Wash Pump Check Valve
No photo available		Wash Pump Piston Kit
No photo available	A5-69-4050	Wash Solvent Supply Line
No photo available	00-77-2010	A5 Waste Bottle
No photo available	00-42-5030	Exhaust tubing, 6ft
No photo available	A5-63-0040	Heated Nozzle Assembly (New)
No photo available		Heated Nozzle Assembly (Exchange)
No photo available	A5-69-4090	A5 Waste Line
Agilent Binary Pump		
	00-73-1020	Agilent Pump Seals
	00-73-2010	Check Valve Cartridge; 0.125 ball [fit all supplied Agilent and A5 CV holders]
	00-73-2140	Check Valve Holder (Outlet - Agilent)
	A5-21-2010	Check Valve Holder Adapter (Agilent - Inlet)
No photo available	A5-60-2740	Lemo Adapter
No photo available		Modifier Purge waste Line
No photo available		Modifier Purge Valve Rebuild Kit

Agilent Autosampler		
No photo available	00-73-3010	3-groove Rotor
No photo available	00-73-6020	Sample Loop, 5 uL
A5 Misc		
No photo available	D005	Passive Splitter Kit
No photo available	A5-69-4110	A5 Test restrictor
No photo available	A5-69-4060	A5 Leak Tray Waste Line
No photo available	00-41-0310	Union
No photo available	00-41-0200	Tee
No photo available		Plug, SS, 10-32 fitting
No photo available		Valco Nut, pkg of 10
No photo available		Valco Ferrule, pkg of 10
No photo available		Check valve frit
No photo available		Plug, PEEK, 1/4-28 fitting
No photo available	00-83-5040	Fuse, 8.0A, 250V, slow blow
A5 Cables		
No photo available	00-84-2040	Relay Cable, HD15M/F (VGA type), 6'
No photo available		Remote Y Cable
No photo available	00-84-2020	BNC Cable
No photo available	00-84-2050	USA Power Cord
No photo available	00-84-2030	Remote Cable, DB9 M/M
No photo available	00-84-2090	USB Cable - 6'

Table A.2
Physical Specifications for the SFC Fusion A5 Module

Physical

Weight	26 kg
Dimensions (h × w × d)	60 × 26 × 48 cm
Line voltage	10 – 240 VAC
Line frequency	50 or 60 Hz
Power consumption	700 VA Max
Operating temperature	15-30 °C
Non-operating temperature	-40 – 70 °C
Humidity	< 95 %, at 25 – 40 °C Non-condensing
Laboratory Ventilation	minimum 6 air exchanges/hr for lab air; CO2 monitor recommended w/ alarm @5000 ppm
Exhaust Vent capacity	>20 liters/min with sustained negative pressure
Operating Altitude	up to 2000 m (6500 ft)
Non-operating altitude	up to 4600 m (14950 ft)
Safety standards:	IEC, NRTL

Table A.3
Chemical Specifications for the SFC Fusion A5 Module

Chemical

Inlet CO2 Bulk Purity	>99.99% vapor; >99.999% liquid [Note 1]
Inlet CO2 Phase	vapor from non-diptube high pressure cylinder; liquid from commercial CO2 delivery system
Inlet CO2 Supply Pressure	40 - 70 bar [580 to 1000 psi]
Inlet CO2 temperature	10 - 30 C
Wash Solvent	HPLC grade alcohol
Liquid Coolant	30% propylene glycol in deionized water; proprietary antioxidants; red dye added for safety
Coolant volume	< 300 mL

Note 1: Inlet CO2 purity to 99.9999% can be achieved from lower grades of CO2 [e.g USP grade] by sampling only from the vapor phase of high pressure cylinders. The resulting distillation purifies the CO2 of the vast majority of UV and MS active compounds that interfere with trace analysis.

Table A.4
Wetted Material Specifications for the SFC Fusion A5 Module
Wetted Materials

High Pressure flow path	300 and 400 series stainless steel PEEK, Carbon filled PEEK Teflon, PTFE, FEP, CTFE UHMW PE Ruby, sapphire, ceramic
Low Pressure flow paths [Waste; Wash Pump; Leak Tray]	316 Stainless steel PEEK Teflon, PTFE, FEP, CTFE CPE; LDPE Tygon PVC
Vapor Exhaust	Tygon PVC

Table A.5
Performance Specifications for the SFC Fusion A5 Module

Performance

Hydraulic system	Single piston with proprietary motor control
Total Hydraulic Volume	< 5 mL @ pressure < 70 bar < 25 mL @ pressure up to 400 bar
Chiller system	Thermoelectric cooling with secondary air/liquid cooling circuit
Back Pressure Regulation (BPR) System	Low volume diaphragm type with proprietary drive control; replaceable BPR head assy; No required recalibration after head replacement
Chiller temperature	- 20 to 9 C variable with flow and pressure demand
Booster Pump Speed range	0 - 6000 steps/sec average step rate
Booster Pump Pressure range	100 - 400 bar up to 5 ml/min demand
Pressure pulsation	< 2 % amplitude at pump speed > 300 st/sec and outlet pressure >100 bar
BPR Thermal range	40 -70 °C (104 - 158 F)
BPR Thermal precision	± 1 °C
BPR Pressure range	100 - 400 bar
BPR Pressure accuracy	Better than 2% after calibration to host Pump
BPR Pressure precision	Better than ±0.5 bar [±0.2 bar typical] measured downstream of separation column
Control and data evaluation	Agilent ChemStation for LC with SFC Fusion A5 driver; Aurora A5 Diagnostic Program
Analog in pressure monitoring	1 V FS; one input; range set by calibration to host pump
Communications	USB 2.0; APG Remote: ready, start, stop and shut-down signals; relay contact closure [wash pump only]

Table A6
TEXT Listing of DEF_SFC.MTH
Method Control Parameters

Method Information	
Method: C:\CHEM32\1\METHODS\DEF_SFC.M	
Modified: 11/13/2009 at 12:17:30 PM	
Run Time Checklist	
Pre-Run Cmd/Macro:	off
Data Acquisition:	on
Standard Data Analysis:	on
Customized Data Analysis:	off
Save GLP Data:	off
Post-Run Cmd/Macro:	off
Save Method with Data:	on
=====	
Agilent 1100/1200 Binary Pump 1	
=====	
Control	
Column Flow	: 0.000 ml/min
Stoptime	: 1.00 min
Posttime	: Off
Solvents	
Solvent A 1	: 80.0 % (CO2)
Solvent B 1	: 20.0 % (MeOH)
PressureLimits	
Minimum Pressure	: 0 bar
Maximum Pressure	: 400 bar
Auxiliary	
Maximal Flow Ramp	: 100.00 ml/min^2
Compressibility A	: 0*10^-6/bar
Minimal Stroke A	: Auto
Compressibility B	: 130*10^-6/bar
Minimal Stroke B	: Auto
Store Parameters	
Store Ratio A	: Yes
Store Ratio B	: Yes
Store Flow	: Yes
Store Pressure	: Yes
Timetable is empty	
=====	
Aurora Sfc Systems SFC Fusion A5 SFC Interface	
=====	
Control	
Stoptime	: AsMethod
System Pressure	: 200 bar
Nozzle Temperature	: 60 C

Agilent 1100/1200 Diode Array Detector SL 1

Signals

Signal	Store	Signal,Bw	Reference,Bw	[nm]
A:	Yes	254 16	360 40	
B:	No	225 16	360 40	
C:	No	250 16	360 40	
D:	No	275 16	360 40	
E:	No	280 16	360 100	
F:	No	280 16	360 100	
G:	No	280 16	360 100	
H:	No	280 16	360 100	
K:	No	Board Temperature		
L:	No	Optical Unit Temperature		
M:	No	UV Lamp Anode Voltage		

Spectrum

Store Spectra : None

Time

Stoptime : As pump
 Posttime : Off

Required Lamps

UV lamp required : Yes
 Vis lamp required : No

Autobalance

Prerun balancing : Yes
 Postrun balancing : No
 Margin for negative Absorbance: 100 mAU

Peakwidth : > 0.05 min
 Slit : 16 nm

Analog Outputs

Zero offset ana. out. 1: 5 %
 Zero offset ana. out. 2: 5 %
 Attenuation ana. out. 1: 1000 mAU
 Attenuation ana. out. 2: 1000 mAU

Timetable is empty

```

=====
                        Agilent 1100/1200 Autosampler 1
=====
Injection
  Injection Mode       :      Injector Program
  Injector volume     :      15.00 µl
  Optimization        :      none

Auxiliary
  Drawspeed           :      100 µl/min
  Ejectspeed          :      100 µl/min
  Draw position       :      0.0 mm

Time
  Stoptime            :      As Pump
  Posttime            :      Off

Injector program table

  Row  Action
  |----|-----|
  1  NEEDLE down
  2  CONTACT B CLOSED.
  3  WAIT 0.10 min
  4  CONTACT B OPEN.
  5  VALVE bypass
  6  DRAW 2.0 µl from air
  7  DRAW def. amount from sample
  8  DRAW 3.0 µl from air
  9  EJECT max. amount into seat
  10 VALVE mainpass + start pulse
  11 CONTACT B CLOSED.
  12 WAIT 0.10 min
  13 CONTACT B OPEN.

Agilent Contacts Option
=====
  Contact 1           :      Open
  Contact 2           :      Open
  Contact 3           :      Open
  Contact 4           :      Open

Agilent Contacts Option Timetable
=====
Timetable is empty

=====
                        Agilent 1100/1200 Column Thermostat 1
=====
Temperature settings
  Left temperature    :      37.5°C
  Right temperature   :      40.0°C
  Enable analysis     :      When Temp. is within setpoint +/- 0.5°C
  Store left temperature :      Yes
  Store right temperature:      No

Time
  Stoptime            :      As pump
  Posttime            :      Off

Column Switching Valve :      Column 1

Timetable is empty

```