

Xinger®

Micro Xinger 3dB Hybrid Coupler



Description

The 1M703 Micro Xinger® is a low profile, miniature 3dB hybrid coupler in an easy to use surface mount package designed for ISM and LMDS applications. The 1M703 is designed for balanced amplifiers and signal distribution and is an ideal solution for the ever-increasing demands of the wireless industry for smaller printed circuit boards and high performance. Parts have been subjected to rigorous qualification testing and units are 100% tested. They are manufactured using materials with x and y thermal expansion coefficients compatible with common substrates such as FR4, G-10 and polyamide.

Features:

- 3.3 – 3.7 GHz
- Low Loss
- High Isolation
- 90° Quadrature
- Surface Mountable
- Tape And Reel
- New Micro-Package
- 100% Tested

ELECTRICAL SPECIFICATIONS**

Frequency	Isolation	Insertion Loss	VSWR		
GHz	dB Min	dB Max	Max:1		
3.3 – 3.7	23	0.20	1.19		
Amplitude Balance	Phase Balance	Power	ΘJC	Operating Temp.	
dB Max	Degrees	Ave. CW Watts	°C/Watt	°C	
± 0.20	± 4	30	52.3	-55 to +85	

**Specification based on performance of unit properly installed on microstrip printed circuit boards with 50 Ω nominal impedance. Specifications subject to change without notice.

Outline Drawing

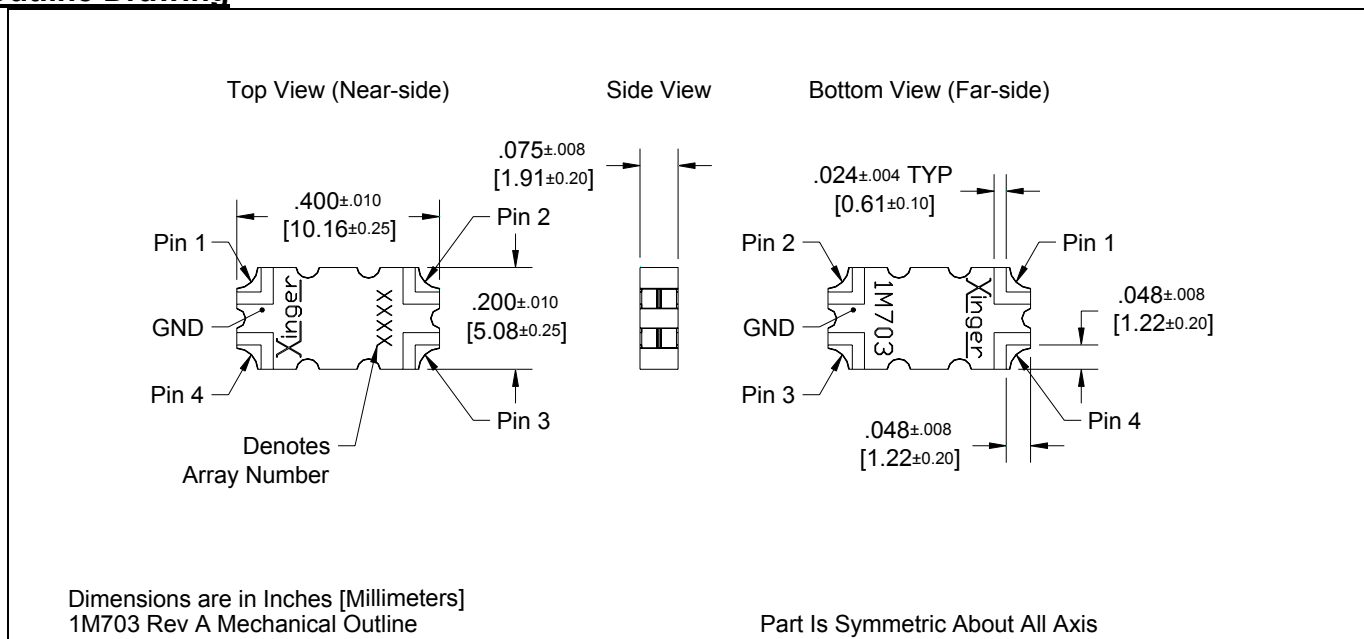

Typical Performance: 3.0 GHz. to 4.0 GHz.

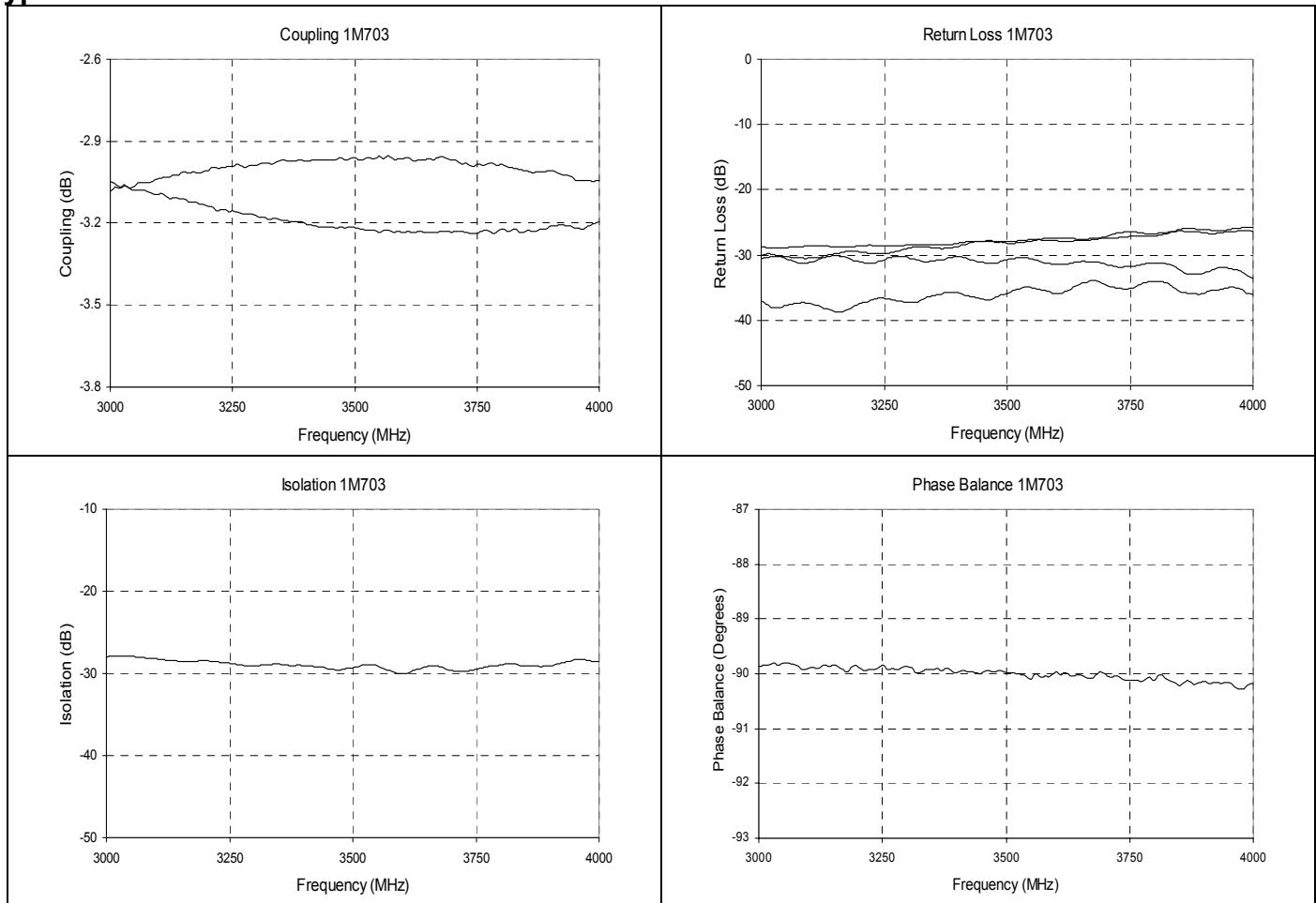

Pin Configuration

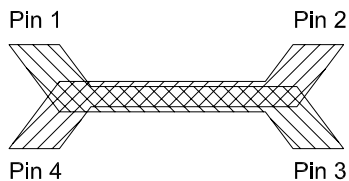

Hybrid Coupler Pin Configuration

	Pin 1	Pin 2	Pin 3	Pin 4
Configuration #1	Input	Isolated	-3dB, -90°	-3dB, 0°
Configuration #2	Isolated	Input	-3dB, 0°	-3dB, -90°
Configuration #3	-3dB, -90°	-3dB, 0°	Input	Isolated
Configuration #4	-3dB, 0°	-3dB, -90°	Isolated	Input

Mounting Footprint

To ensure proper electrical and thermal performance there must be a ground plane with 100% solder connection underneath the part

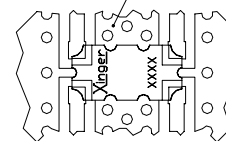

Part Is Symmetric About All Axis

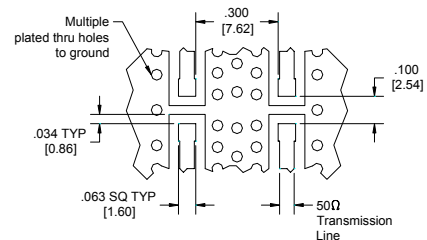

Dimensions are in Inches [Millimeters]
1M703 Rev A Mounting Footprint

USA/Canada: (315) 432-8909
Toll Free: (800) 544-2414
Europe: +44 2392-232392

Available on Tape and Reel For Pick and Place Manufacturing.

