



Surface Mount Termination 16 Watts, 50Ω



General Specifications

Resistive Element	Thick film
Substrate	Aluminum nitride ceramic
Terminals	Tin/Lead, 90/10 over Nickel

Electrical Specifications

Resistance Range:	50 ohms, $\pm 2\%$
Frequency Range;	DC – 3.0 GHz
Power:	16 Watts
VSWR	1.25:1 DC – 3.0 GHz

Note: Tolerance is $\pm 0.010"$, unless otherwise specified. Designed to meet or exceed applicable portions of MIL-E-5400. Operating temperature is -55°C to 125°C (see chart for derating temperatures). All dimensions in inches.

Specifications subject to change with out notice.

Features:

- DC – 3.0 GHz
- 16 Watts
- Aluminum Nitride (AlN) Ceramic
- Non-Nichrome Resistive Element
- Low VSWR
- 100% Tested

Outline Drawing

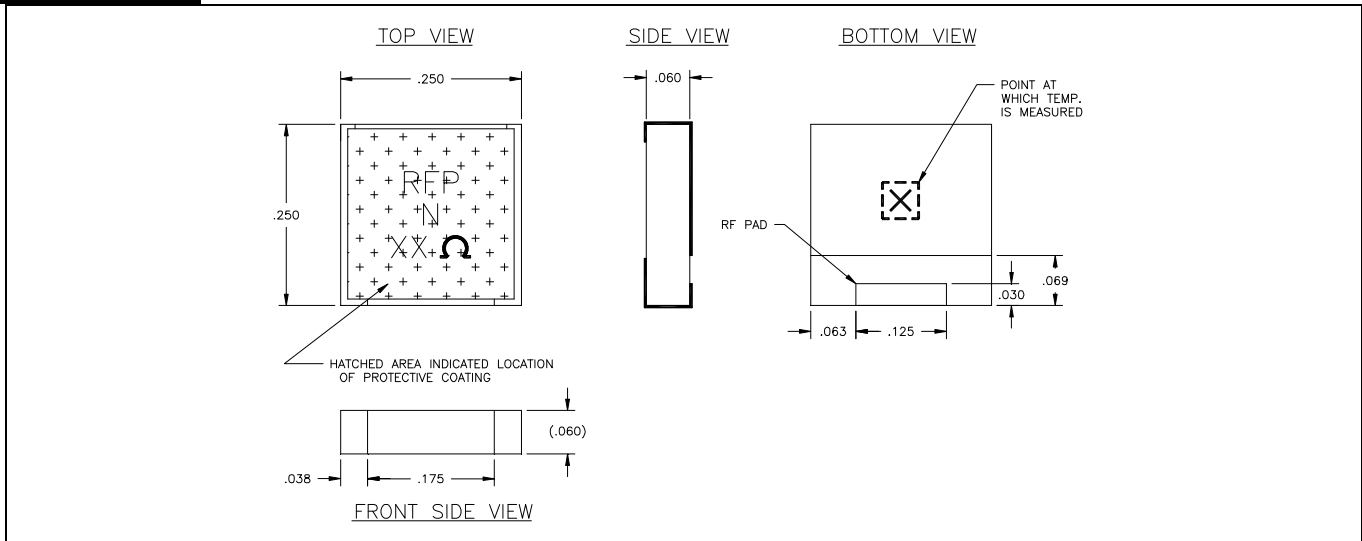

250250N6Z50 (097) Rev A

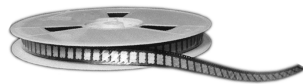



Typical Performance:

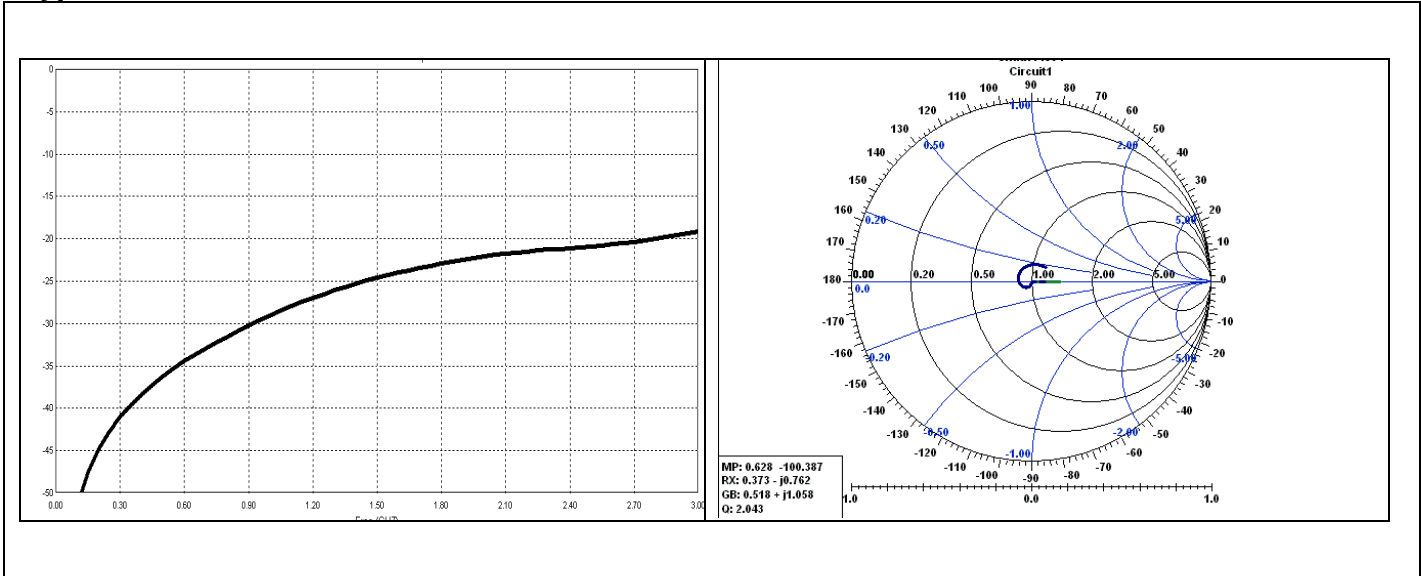

Power De-rating:

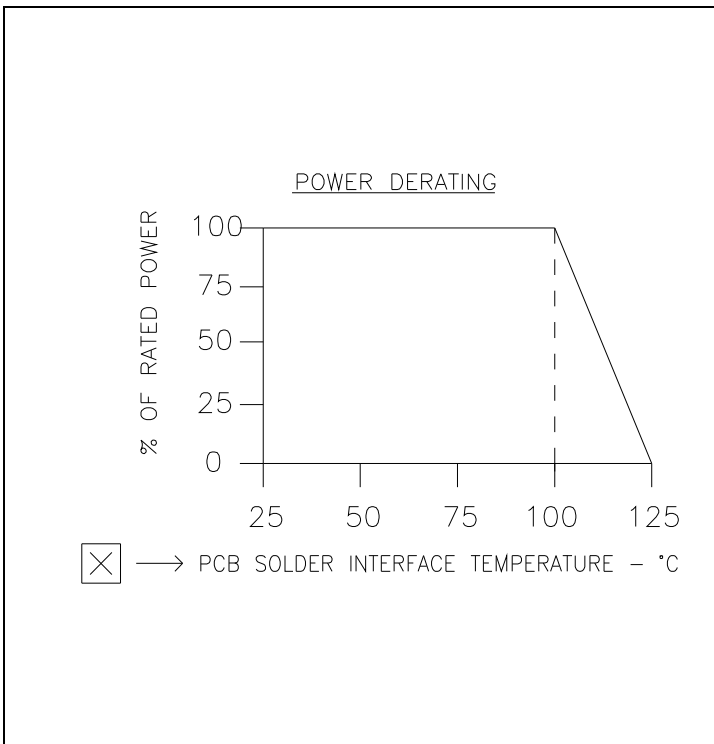

Mounting Footprint and Procedure:

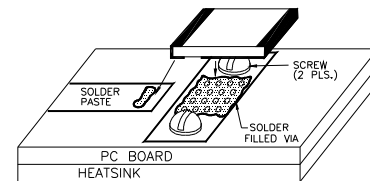

MOUNTING PROCEDURE

SUGGESTED MOUNTING PROCEDURES:

1. MAKE SURE THAT THE DEVICES ARE MOUNTED ON FLAT SURFACES (.001" UNDER THE DEVICE) TO OPTIMIZE THE HEAT TRANSFER.
2. DRILL & TAP THE HEATSINK FOR THE APPROPRIATE THREAD SIZE TO BE USED.
3. COAT HEATSINK WITH A MINIMUM AMOUNT OF HIGH QUALITY SILICONE GREASE (.001" MAX. THICKNESS).
4. POSITION DEVICE ON MOUNTING SURFACE & SECURE USING SOCKET HEAD SCREWS, FLAT & SPLIT WASHER. TORQUE SCREWS TO THE APPROPRIATE VALUE. MAKE SURE THAT THE DEVICE IS FLAT AGAINST THE HEATSINK. (CARE SHOULD BE TAKEN TO AVOID UPWARD PRESSURE OF THE LEADS TOWARDS THE LID).
5. SOLDER LEADS IN PLACE USING APPROPRIATE SOLDER WITH A CONTROLLED TEMPERATURE IRON.

** FOR MORE DETAILS CONTACT FACTORY **

250250N6Z50 (097) Rev A

USA/Canada: (315) 432-8909
Toll Free: (800) 544-2414
Europe: +44 2392-232392

Available on Tape and Reel For Pick and Place Manufacturing.

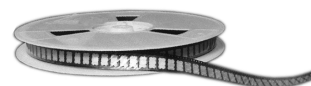

Anaren
What'll we think of next?™