

Xinger®

Xinger Balun 50Ω to 100Ω Balanced



Description

The 4859B50-50C is a low profile sub-miniature balanced to unbalanced transformer designed for differential inputs and output locations on next generation wireless chipsets in an easy to use surface mount package covering 802.11a Uni-Band II and Uni-Band III and the Japanese ISM band (4.9GHz). The 4859B50-50C is ideal for high volume manufacturing and is higher performance than traditional ceramic baluns. The 4859B50-50C has an unbalanced port impedance of 50Ω and a 100Ω balanced port impedance*. This transformation enables single ended signals to be applied to differential ports on modern integrated chipsets. The output ports have equal amplitude (-3dB) with 180 degree phase differential. The 4859B50-50C is available on tape and reel for pick and place high volume manufacturing.

Features:

- 5.15 – 5.35 GHz Narrow Band
- 4.8 – 5.9 GHz Extended Band
- 180° Transformer
- 50 Ohm to 2 x 50 Ohm
- Low Insertion Loss
- Covers 802.11a Uni-Band II & III
- No DC Decoupling Capacitors Required
- Input to Output DC Isolation
- Surface Mountable
- Tape & Reel
- Convenient Package

ELECTRICAL SPECIFICATIONS**

Frequency	Unbalanced Port Impedance	Balanced Port Impedance*	Return Loss	Insertion Loss
GHz	Ohms	Ohms	dB min	dB max
5.15 – 5.35	50	100	17	0.5***
4.8 – 5.9			16	0.6***
Amplitude Balance	Phase Balance	Power Handling	ΘJC	Operating Temp.
dB	Degrees max	Watts	°C / Watt	°C
0 ± 0.5	180 ± 5.0	4	75	-55 to +85
0 ± 0.6	180 ± 5.0			

**Specification based on performance of unit properly installed on microstrip printed circuit boards with 50 Ω nominal impedance. Specifications subject to change without notice.

* 50Ω reference to ground *** Insertion Loss stated at room temperature (0.55 dB Max at +85 °C)

Outline Drawing

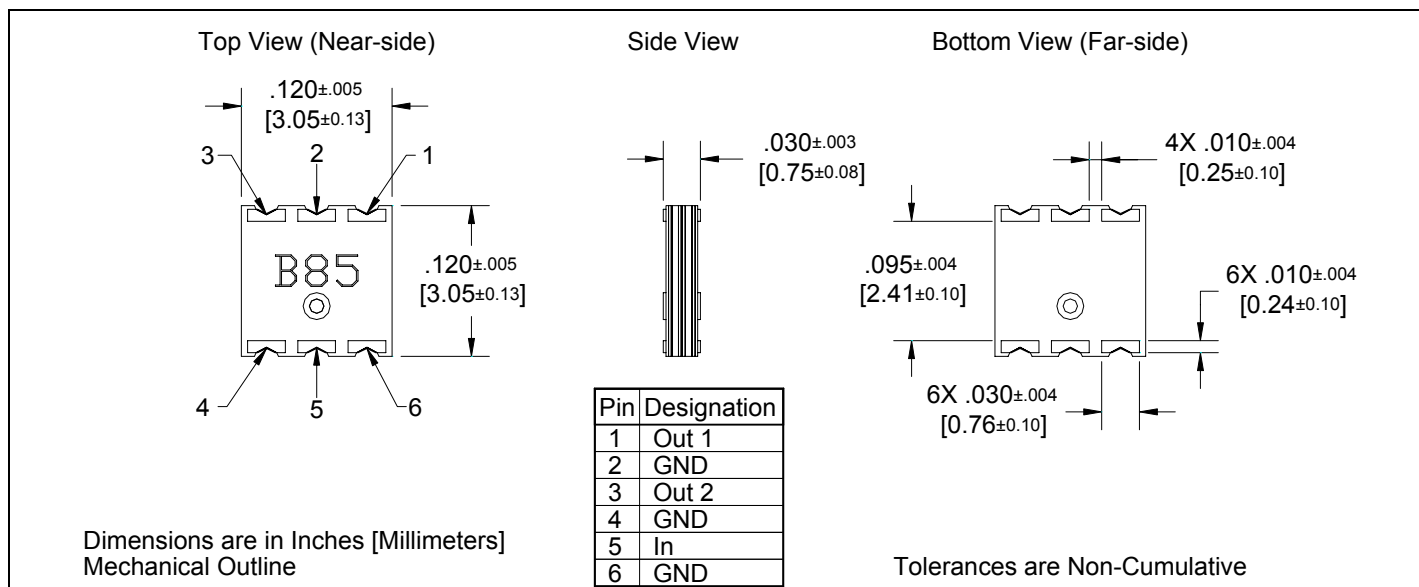

Typical Performance: 4.5 GHz. to 6.0 GHz.

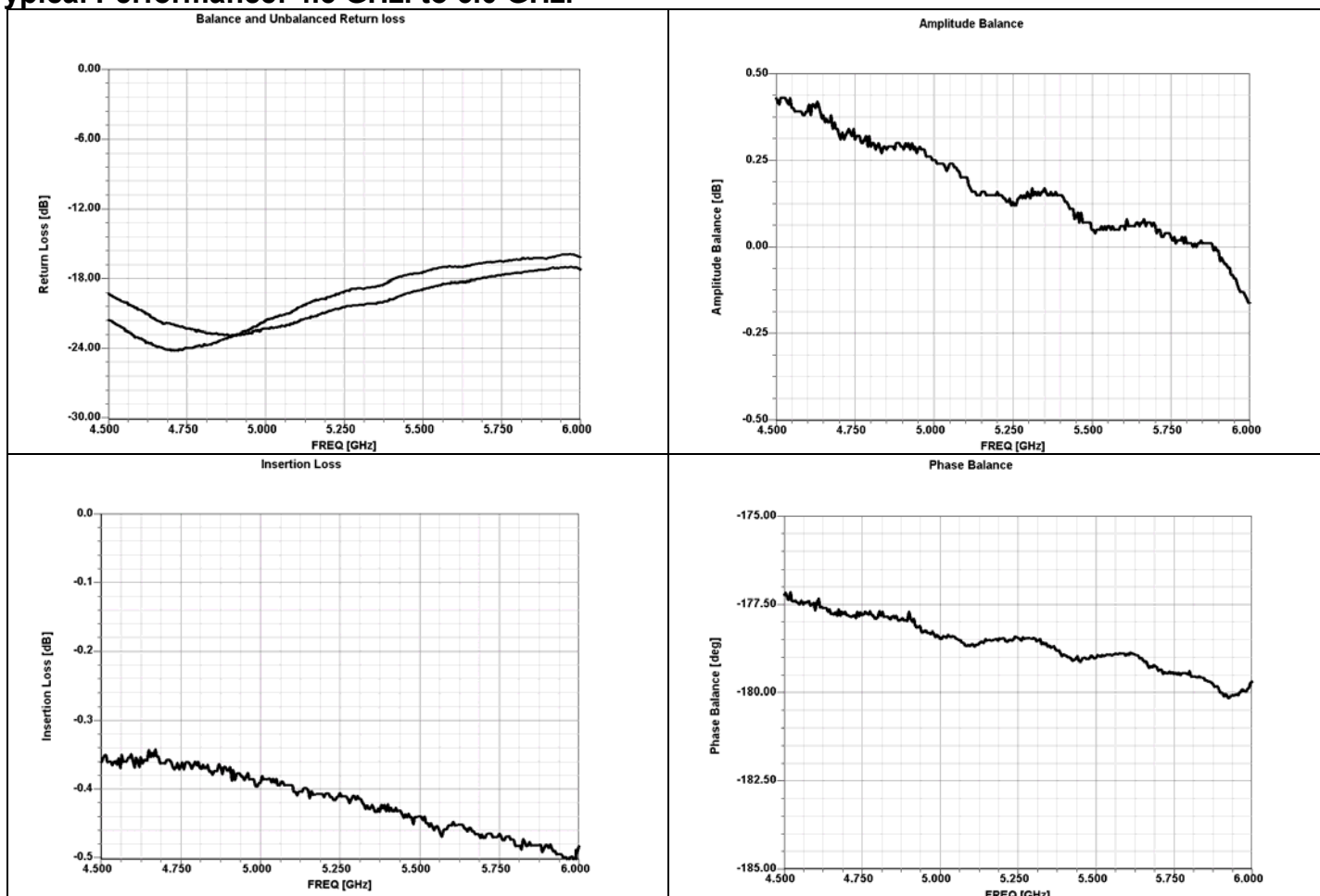

Pin Configuration:

Balun Pin Configuration

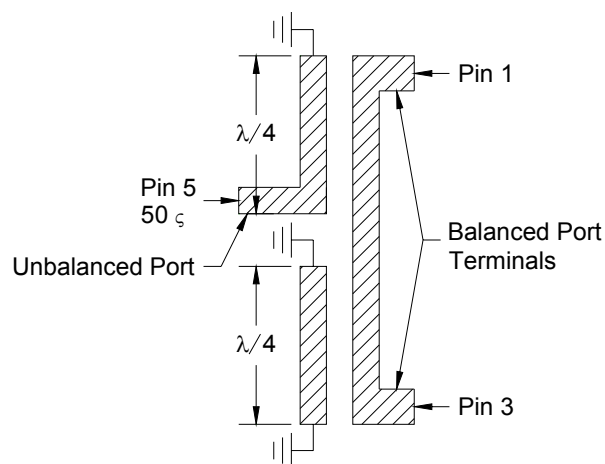

The internal configuration of the Xinger® balun is diagrammed to the left; the unbalanced port is DC connected to ground and the two balanced ports are DC connected and floating. For many chipset applications there is an opportunity to eliminate two decoupling capacitors and/or use a single bias point if applicable. Differential drive is popular in integrated circuit since it aids stability in the presence of bond wire and pin inductance, provides some degree of immunity to power supply and ground noise, and can provide higher output power in the case of some device limits. The construction of the Xinger® balun is bonded multi-layered stripline made of low loss dielectric material with plated through vias connecting the internal circuitry to the external printed circuit board, similar to that of the Xinger® hybrids and directional couplers.



Typical Performance: 5.15 GHz. to 5.35 GHz.

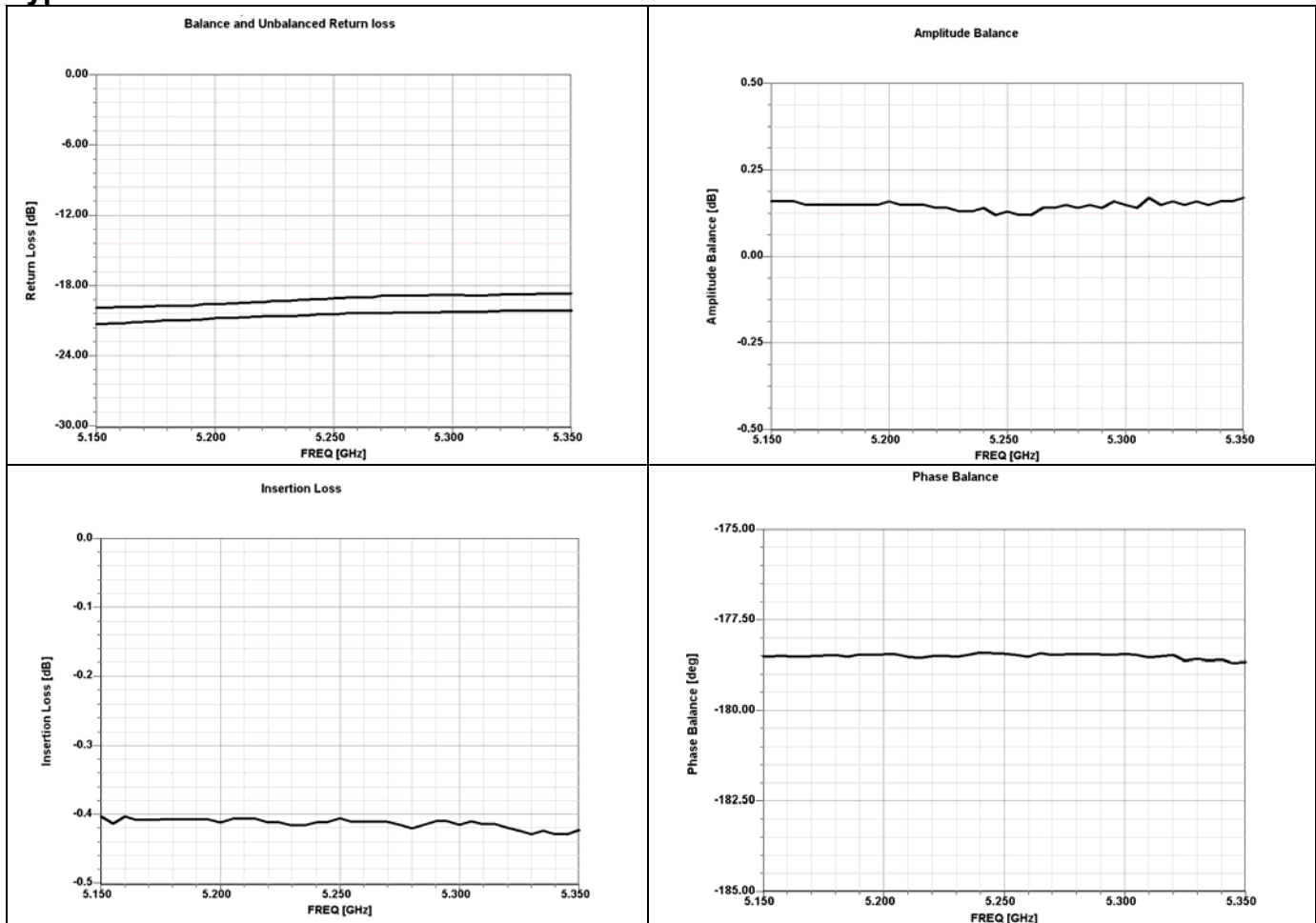

Mounting Configuration:

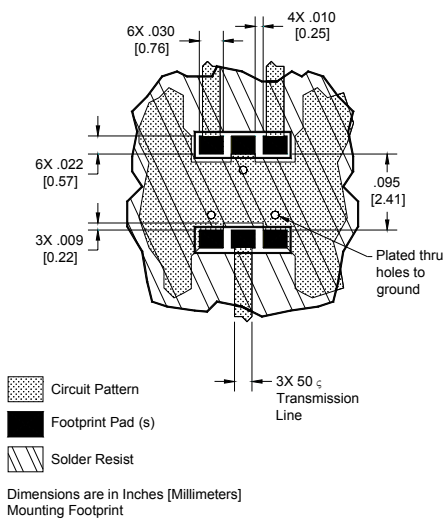

In order for Xinger surface mount components to work optimally, there must be a 50Ω transmission line to the balanced port and 50Ω transmission lines from the unbalanced ports. If this condition is not satisfied, amplitude balance, insertion loss and VSWR may not meet published specifications.

All of the Xinger components are constructed from ceramic filled PTFE composites which possess excellent electrical and mechanical stability having X and Y thermal coefficient of expansion (CTE) of 17 ppm/°C

An example of the PCB footprint used in the testing of these parts is shown to the left. In specific designs, the transmission line widths need to be adjusted to the unique dielectric coefficients and thicknesses as well as varying pick and place equipment tolerances.



Packaging and Ordering Information

Parts are available in reel and are packaged per EIA 481-2. Parts are oriented in tape and reel as shown below. Minimum order quantities are 4000 per reel. See Model Numbers below for further ordering information.

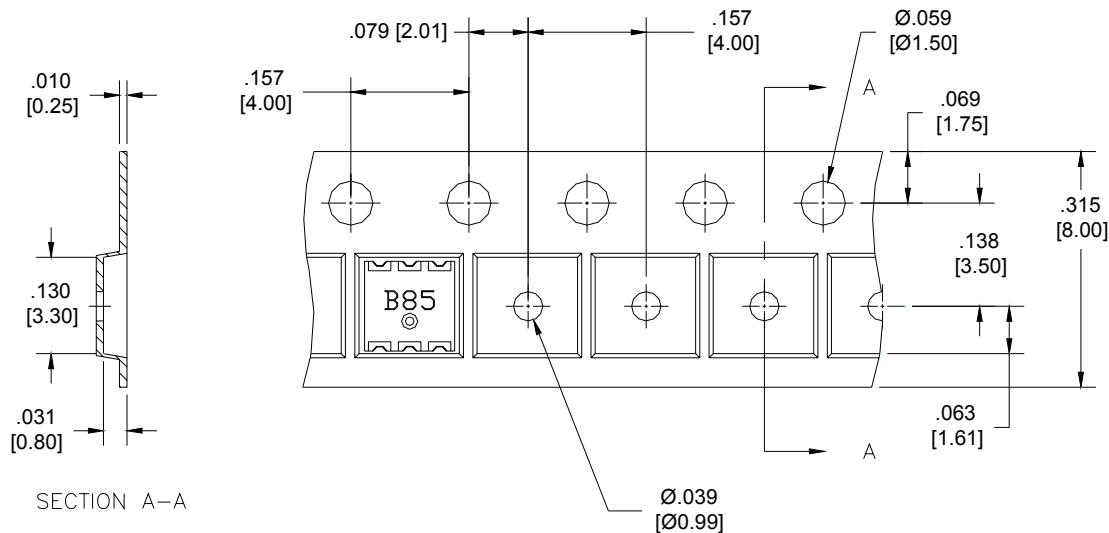

Dimensions are in inches [mm]

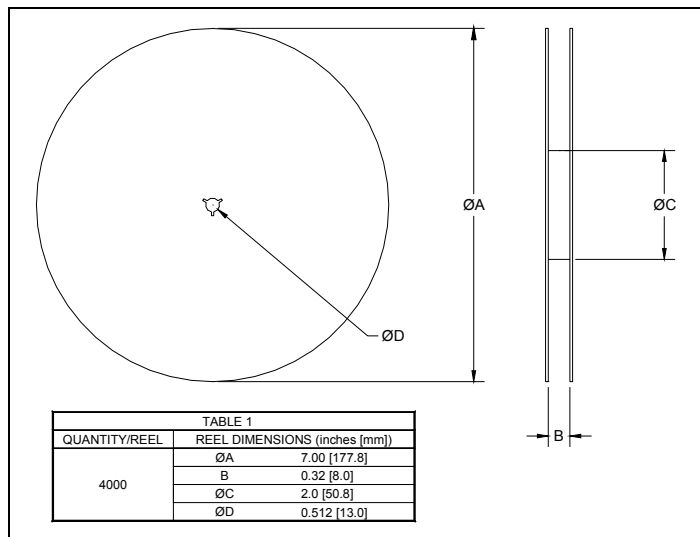
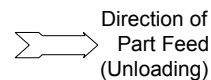

USA/Canada: (315) 432-8909
 Toll Free: (800) 544-2414
 Europe: +44 2392-232392

Available on Tape and Reel For Pick and Place Manufacturing.



Anaren

What'll we think of next

4859 B 50-12 A P R

Frequency	Function	Input Impedance	Output Impedance + Coupling	Package Dimensions	Plating	Shipping Package
00550 = 50 - 500 MHz	B = Balun	50 = 50 Ohm	12 = 12.5Ω to Ground	A = 150 x 150 mils (4mm x 4mm)	P = Lead	R = Reel
0110 = 100 - 1000 MHz	F = Filter	75 = 75 Ohm	15 = 15Ω to Ground	C = 120 x 120 mils (3mm x 3mm)	S = Tin	B = Bulk
0910 = 900 - 1000 MHz	FB = Filter / Balun		25 = 25Ω to Ground	E = 100 x 80 mils (2.5mm x 2mm)		
0921 = 900 - 2100 MHz	C = 3dB Coupler		37 = 37.5Ω to Ground	G = 120 x 60 mils (3mm x 1.5mm)		
1222 = 1200 - 2200 MHz	DC = Directional		50 = 50Ω to Ground	J = 80 x 50 mils (2mm x 1.25mm)		
1416 = 1400 - 1500 MHz	CR = Circulator		75 = 75Ω to Ground	L = 60 x 30 mils (1.5mm x 0.75mm)		
1718 = 1700 - 1800 MHz	DB = Dual Balun		100 = 100Ω to Ground	N = 140 x 80 mils (3.5mm x 2mm)		
1719 = 1700 - 1900 MHz			03 = 3dB Hybrid			
1819 = 1800 - 1900 MHz			10 = 10dB Directional			
2122 = 2100 - 2200 MHz			20 = 20dB Directional			
2022 = 2000 - 2200 MHz			C = Clockwise			
2425 = 2400 - 2500 MHz			AC = Anti Clockwise			
3436 = 3400 - 3600 MHz						
4859 = 4800 - 5900MHz						
5153 = 5100 - 5300 MHz						
5159 = 5100 - 5900 MHz						
5759 = 5700 - 5900 MHz						
1414 = 14000- 14500 MHz						
0819 = 800 + 1900 MHz						

