

RF Power introduced its first product in 1987 and has since designed, manufactured and supported the most reliable line of high-power resistive components in the industry. Employing state-of-the-art equipment, manufacturing and quality assurance practices, our line of resistors, terminations and attenuators continue to be among the most cost effective, innovative and reputable solutions in the industry. In addition, RF Power's commitment to customer service excellence has resulted in our receiving several quality awards from major customers.

Traditionally, high-power resistive components have been constructed using a Beryllium Oxide (BeO) ceramic substrate. In recent years several governments and agencies have enacted prohibitions against the use of Beryllium Oxide. In response to these industry developments, RF Power undertook a research and development mission to develop an effective alternative to BeO, using an Aluminum Nitride (AlN) ceramic in its place. AlN has thermal and electrical properties comparable to BeO, but none of the environmental issues associated with it. The most recent addition to our product offering is a new line of RF Power Alumina (Al₂O₃) terminations. Alumina has electrical properties comparable to both BeO and AlN, but with a reduced power handling capability. This line is intended as a low-cost alternative to both BeO and AlN for less demanding applications.

RF Power high-power resistive products are widely used in the wireless industry, as well as in medical, industrial, military and aerospace applications. Our resistive products cover a wide range of communications bands, such as NMT-450, NMT-900, AMPS, ETACS, IS-95, GSM, DCS, PCS, W-CDMA, 3G, Wireless LAN, WCS, ISM and satellite communication bands. Typical applications for our products would be in splitter and combiner networks for power amplifiers, signal sensing in feed-forward amplifiers, isolator and circulator construction, delay line and cavity filter assemblies, and high power RF generators.

RF Power high-power resistive components are available in a wide variety of mechanical configurations including surface mount, chip, flanged, flangeless, coaxial and cable load.

Introduction

Anaren

RF Power

INSTALLATION DETAILS-

Surface Mount-

When mounting surface mount resistors, it is important to ensure that the best possible thermal path exists between the resistor and the heat sink. This should be done using solder filled vias to connect the ground pad on the resistor with the heat sink. To further improve the thermal connection, two screws should be mounted on either side of the resistor, pressing the PC board tightly against the heat sink.

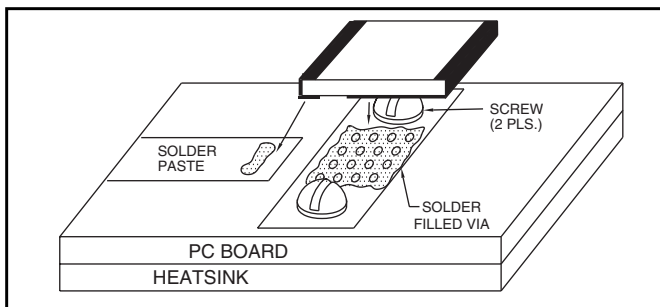

It is important to keep in mind that the power handling specified for the given resistor assumes that the recommended mounting procedure is followed.

Footprint: When making a footprint for a surface

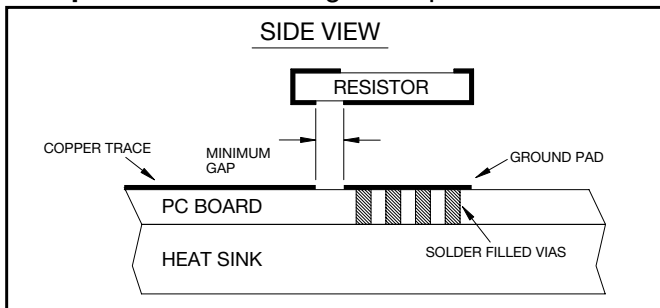

mount resistor, it is important to leave a gap between the input trace and the ground pad that is no less than the gap present on the resistor. All other footprint dimensions can be sized as desired. It is recommended to make traces 10-20 mils

larger than the solder terminals on the resistors (to allow for a solder fillet).

Chip and Flangless-

Chip and flangeless resistors should be mounted directly on a flat heat sink surface (0.001" under the device) to achieve the best possible thermal connection to the heat sink. Mount the resistor using a solder with a melting point higher than the one used when attaching the lead.

When mounting the lead, make sure that a stress relief is present either in the form of a small loop or a large S-style bend.

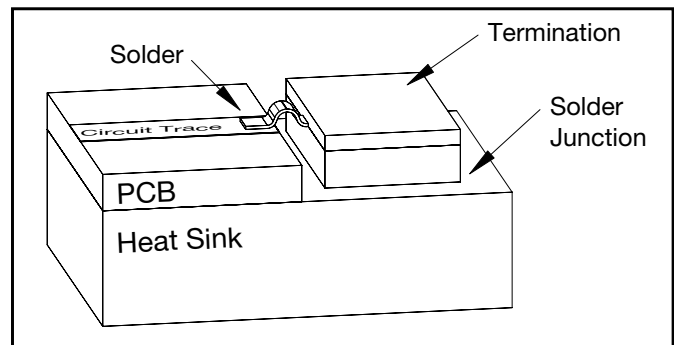

If no stress relief is present repeated thermal cycling will cause metal fatigue in the lead and cause it to break or detach.

Epoxy-

Conductive epoxies such as silver epoxy can also be used to mount the resistor, but be aware that the silver epoxy has a much lower thermal conductivity than solder. The thickness of the silver epoxy used to mount the resistor should be kept to a minimum to avoid introducing a thermally insulating layer between the resistor and heat sink. Be aware that if the resistor is used in a sealed package, outgassing from the epoxy may contaminate other parts.

Flanged-

Flange mounted resistors should be bolted down on a flat surface (0.001" under the device) on the heat sink. The heat sink should be drilled and tapped for the appropriate screw and thread size. To further improve the heat transfer, apply a thin layer (max. 0.001") of high quality thermal grease under the device. Mount the resistor with flat and split washers, and torque screws to appropriate

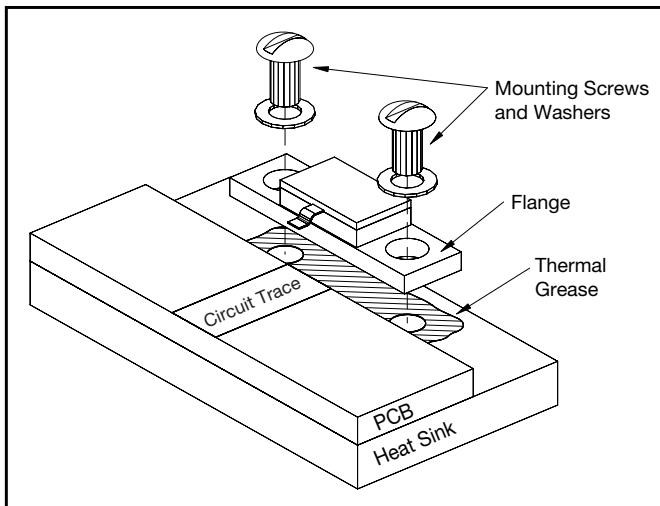

value.

When mounting the lead, make sure that a stress relief is present either in the form of a small loop or a large S-style bend. If no stress relief is present repeated thermal cycling will cause metal fatigue in the lead and make it break or detach.

Introduction

Anaren

RF Power

Tape and Reel-

All RF Power surface mount and chip resistors are available on tape and reel. The parts are packaged with the marking facing up, and oriented to have the input terminal towards the sprocket holes.

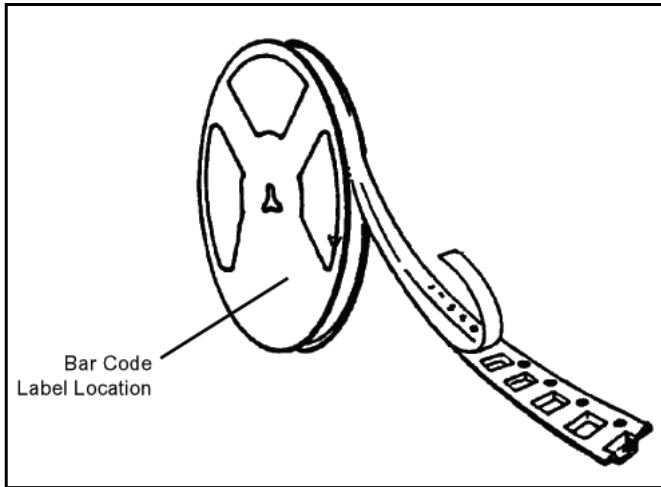

The tape and reel follow the EIA-481-2 Standards with the label mounted on the side.

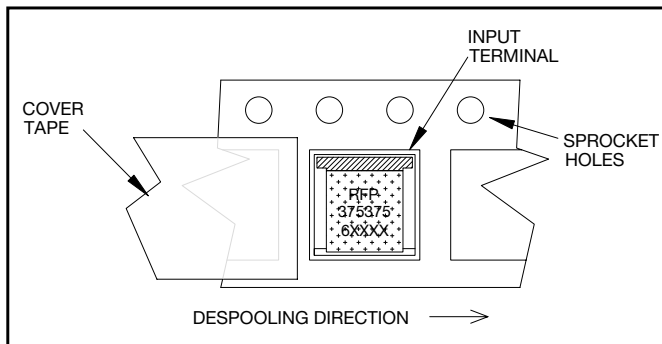

Storage of Components-

Some of the components have a tin/lead surface finish. Commonly used storage procedures used to control oxidation should be followed for these surface mount components.

Tape and Reel Dimensions-

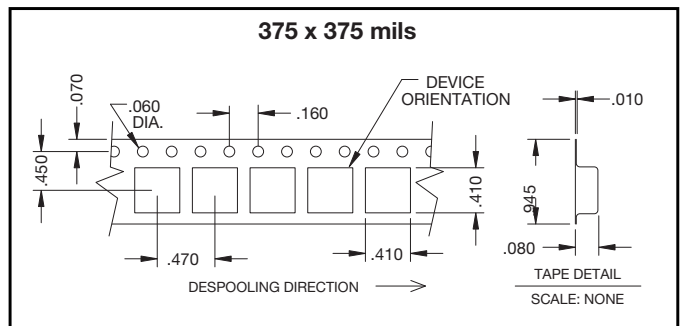
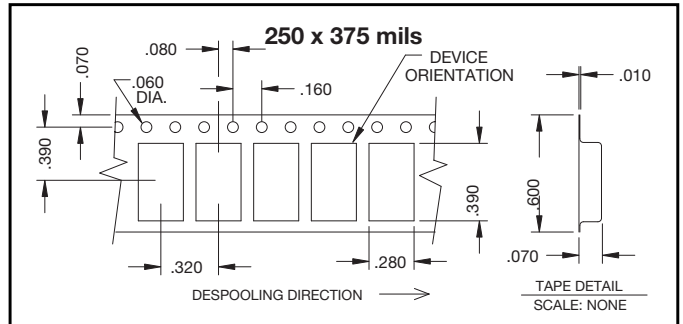
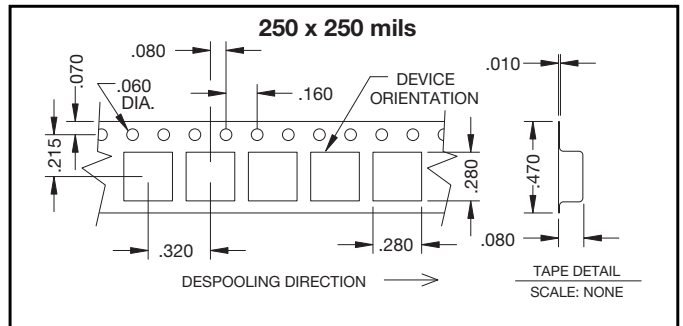
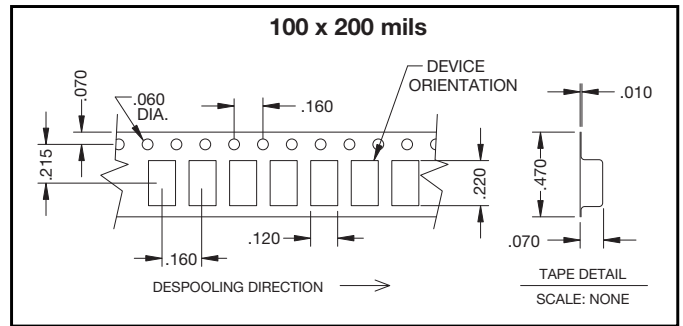

Surface Mount Resistors

Part Number	Power (Watts)	Frequency	Capacitance	Page
RFP-100200-4Y100-2	5	DC-3.0 GHz	0.3 pF	4.2.3
RFP-250250-4Y100-2	8	DC-2.0 GHz	1.0 pF	4.2.5
RFP-250250-6Y100-2	8	DC-2.0 GHz	0.9 pF	4.2.7
RFP-250375-4Y100-2	10	DC-2.0 GHz	1.4 pF	4.2.9
RFP-375375-6Y100-2	30	DC-1.5 GHz	2.0 pF	4.2.11

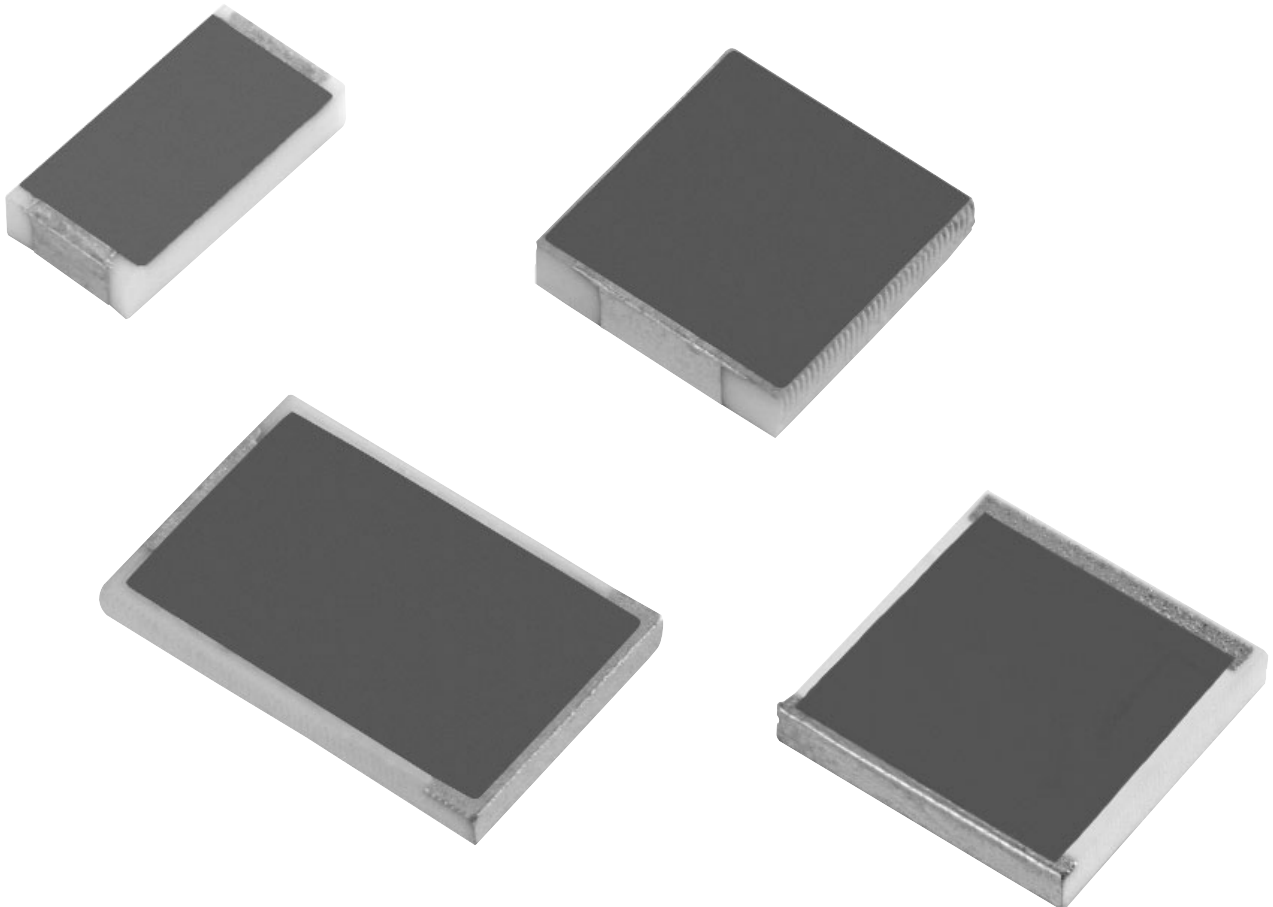

Resistors

Anaren

RF Power

INTRODUCTION-

RF Power surface mount resistors are made as thick film resistor on a ceramic substrate. This allows for maximum flexibility when it comes to power handling and performance.

RESISTOR VALUE-

The standard resistor value is 100Ω, but a wide range of values is available upon request. Standard resistor value tolerance is 2% but 1% and other tolerance values are available upon request.

CAPACITANCE-

All resistors have been designed for low capacitance. The specified capacitance is the parallel plate capacitance to ground measured at 60 Hz. This capacitance is proportional to the resistor film and size, and inversely proportional to the resistor thickness.

FREQUENCY RANGE-

The resistor frequency range is specified as the 3dB impedance range. This means that for a 100Ω resistor, at the highest frequency specified, the impedance magnitude would be 50Ω.

POWER HANDLING-

To achieve the best possible power handling, all resistors in this section are made using Beryllium Oxide (BeO). BeO has a high thermal conductivity, allowing for excellent heat transfer from the resistor to the heat sink.

TERMINALS-

As a standard all RF Power surface mount resistors come with thick film silver soldering terminals, but they are also available in a 150 μin nickel-plated with 300 μin 60/40 solder. Other types of plated terminals are available upon request.

MOUNTING-

RF Power surface mount resistors are ideal for high volume automated production. It is important to follow the described mounting procedure for all surface mount resistors to achieve the best electrical and thermal performance.

PART NUMBERING-

Part numbers are composed in the following way:

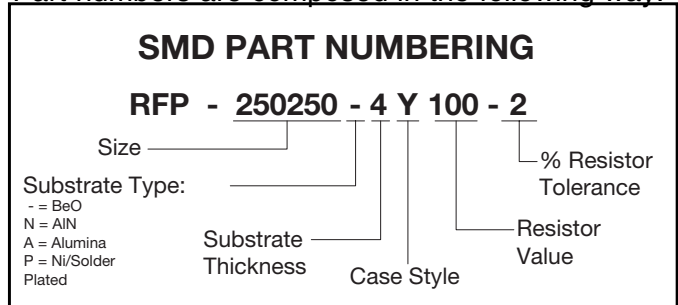

TAPE AND REEL

RF Power surface mount resistors are available on tape and reel for pick and place manufacturing. Please see installation instructions for more information.

www.anaren.com

to locate data sheets and s-parameters

Sales Desk USA: Voice: (800) 544-2414 Fax: (315) 432-9121
 Sales Desk Europe: Voice: (+44) 23 92 232392 Fax: (+44) 23 92 251369