

RF Power introduced its first product in 1987 and has since designed, manufactured and supported the most reliable line of high-power resistive components in the industry. Employing state-of-the-art equipment, manufacturing and quality assurance practices, our line of resistors, terminations and attenuators continue to be among the most cost effective, innovative and reputable solutions in the industry. In addition, RF Power's commitment to customer service excellence has resulted in our receiving several quality awards from major customers.

Traditionally, high-power resistive components have been constructed using a Beryllium Oxide (BeO) ceramic substrate. In recent years several governments and agencies have enacted prohibitions against the use of Beryllium Oxide. In response to these industry developments, RF Power undertook a research and development mission to develop an effective alternative to BeO, using an Aluminum Nitride (AlN) ceramic in its place. AlN has thermal and electrical properties comparable to BeO, but none of the environmental issues associated with it. The most recent addition to our product offering is a new line of RF Power Alumina (Al₂O₃) terminations. Alumina has electrical properties comparable to both BeO and AlN, but with a reduced power handling capability. This line is intended as a low-cost alternative to both BeO and AlN for less demanding applications.

RF Power high-power resistive products are widely used in the wireless industry, as well as in medical, industrial, military and aerospace applications. Our resistive products cover a wide range of communications bands, such as NMT-450, NMT-900, AMPS, ETACS, IS-95, GSM, DCS, PCS, W-CDMA, 3G, Wireless LAN, WCS, ISM and satellite communication bands. Typical applications for our products would be in splitter and combiner networks for power amplifiers, signal sensing in feed-forward amplifiers, isolator and circulator construction, delay line and cavity filter assemblies, and high power RF generators.

RF Power high-power resistive components are available in a wide variety of mechanical configurations including surface mount, chip, flanged, flangeless, coaxial and cable load.

Introduction

Anaren

RF Power

INSTALLATION DETAILS-

Surface Mount-

When mounting surface mount resistors, it is important to ensure that the best possible thermal path exists between the resistor and the heat sink. This should be done using solder filled vias to connect the ground pad on the resistor with the heat sink. To further improve the thermal connection, two screws should be mounted on either side of the resistor, pressing the PC board tightly against the heat sink.

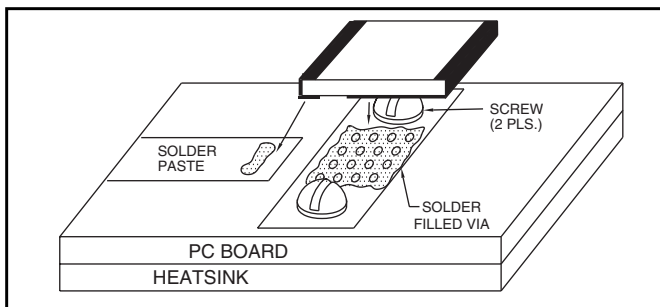

It is important to keep in mind that the power handling specified for the given resistor assumes that the recommended mounting procedure is followed.

Footprint: When making a footprint for a surface

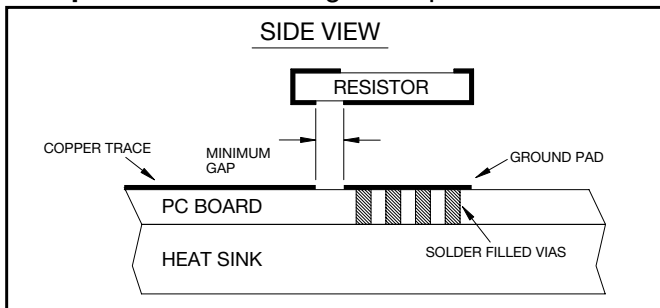

mount resistor, it is important to leave a gap between the input trace and the ground pad that is no less than the gap present on the resistor. All other footprint dimensions can be sized as desired. It is recommended to make traces 10-20 mils

larger than the solder terminals on the resistors (to allow for a solder fillet).

Chip and Flangless-

Chip and flangeless resistors should be mounted directly on a flat heat sink surface (0.001" under the device) to achieve the best possible thermal connection to the heat sink. Mount the resistor using a solder with a melting point higher than the one used when attaching the lead.

When mounting the lead, make sure that a stress relief is present either in the form of a small loop or a large S-style bend.

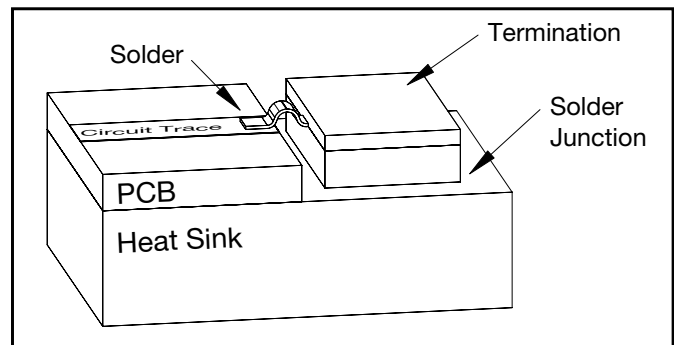

If no stress relief is present repeated thermal cycling will cause metal fatigue in the lead and cause it to break or detach.

Epoxy-

Conductive epoxies such as silver epoxy can also be used to mount the resistor, but be aware that the silver epoxy has a much lower thermal conductivity than solder. The thickness of the silver epoxy used to mount the resistor should be kept to a minimum to avoid introducing a thermally insulating layer between the resistor and heat sink. Be aware that if the resistor is used in a sealed package, outgassing from the epoxy may contaminate other parts.

Flanged-

Flange mounted resistors should be bolted down on a flat surface (0.001" under the device) on the heat sink. The heat sink should be drilled and tapped for the appropriate screw and thread size. To further improve the heat transfer, apply a thin layer (max. 0.001") of high quality thermal grease under the device. Mount the resistor with flat and split washers, and torque screws to appropriate

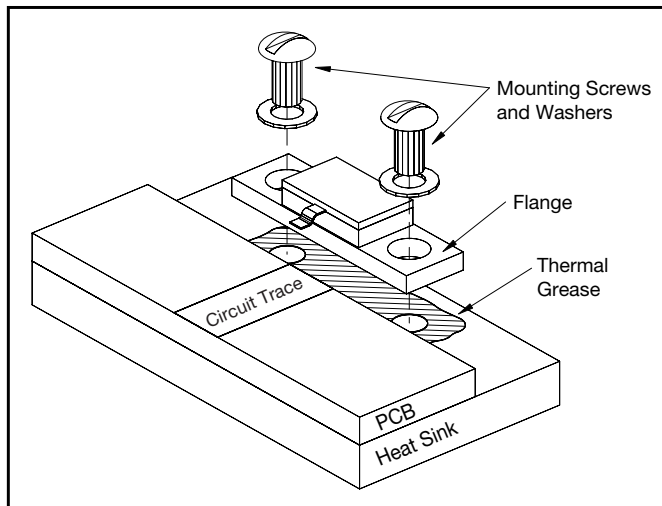

value.

When mounting the lead, make sure that a stress relief is present either in the form of a small loop or a large S-style bend. If no stress relief is present repeated thermal cycling will cause metal fatigue in the lead and make it break or detach.

Introduction

Anaren

RF Power

Tape and Reel-

All RF Power surface mount and chip resistors are available on tape and reel. The parts are packaged with the marking facing up, and oriented to have the input terminal towards the sprocket holes.

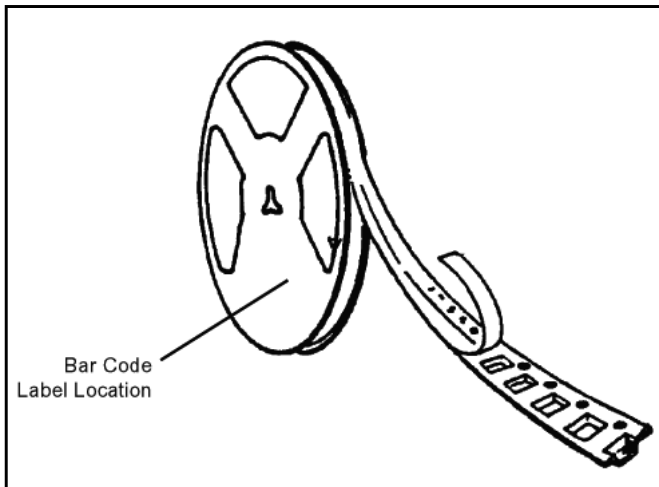

The tape and reel follow the EIA-481-2 Standards with the label mounted on the side.

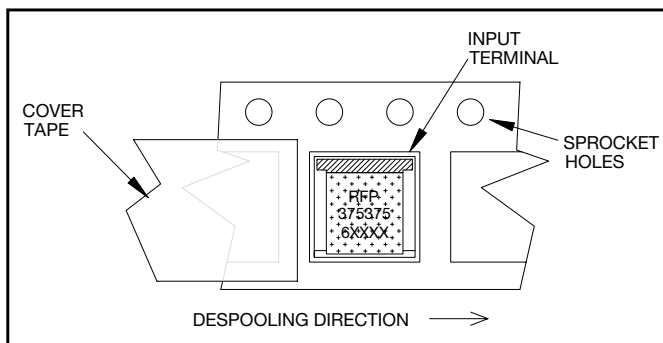

Storage of Components-

Some of the components have a tin/lead surface finish. Commonly used storage procedures used to control oxidation should be followed for these surface mount components.

Tape and Reel Dimensions-

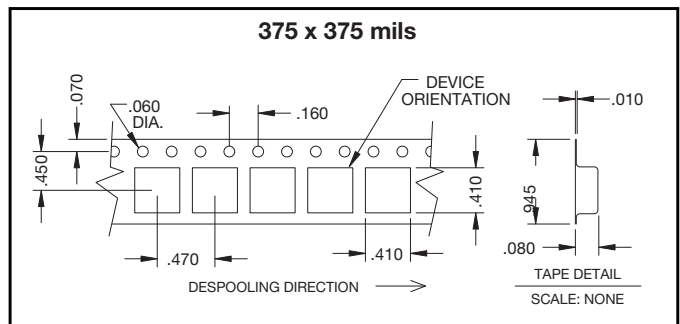
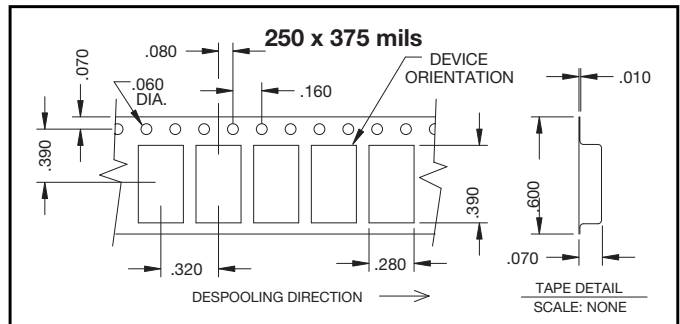
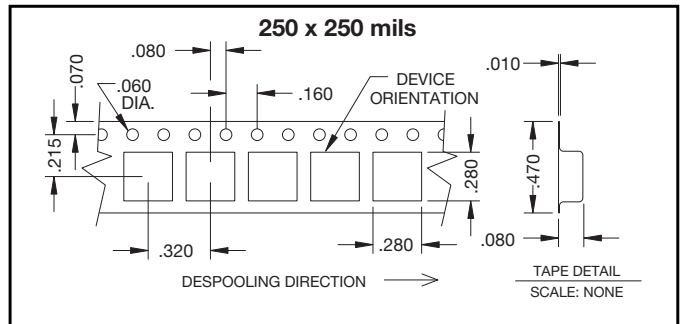
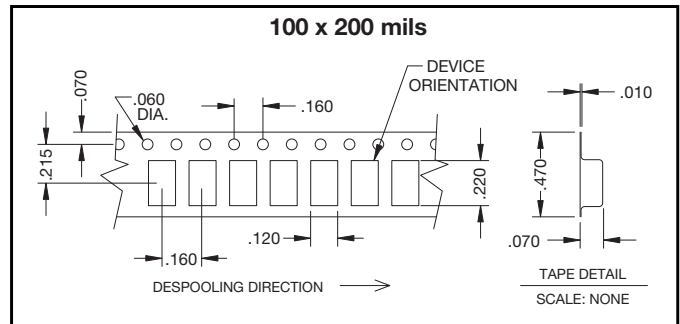

Flangeless Terminations

Part Number	Power (Watts)	Frequency	VSWR Max: 1	Page
RFP-30-50T	30	DC-3.0 GHz	1.25	4.5.5
RFP-40-50TPP	40	DC-6.0 GHz	1.25	4.5.7
RFP-125-50TS	125	DC-3.0 GHz	1.20	4.5.9
RFP-150-50TCGN	150	DC-3.0 GHz	1.40	4.5.11
RFP-200-50TB	200	DC-2.0 GHz	1.35	4.5.13
RFP-300-50TD	300	DC-3.0 GHz	1.30	4.5.15

Flanged Terminations

Part Number	Power (Watts)	Frequency	VSWR Max: 1	Page
RFP-10-50TV	10	DC-4.0 GHz	1.25	4.5.17
RFP-10-50TVC	10	DC-4.0 GHz	1.25	4.5.19
RFP-10-50TVR	10	DC-4.0 GHz	1.25	4.5.21
RFP-10-50TVV	10	DC-4.0 GHz	1.25	4.5.23
RFP-20-50TP	20	DC-6.0 GHz	1.25	4.5.25
RFP-20-50TPC	20	DC-6.0 GHz	1.25	4.5.27
RFP-20-50TPR	20	DC-6.0 GHz	1.25	4.5.29
RFP-40-50TR	40	DC-3.0 GHz	1.25	4.5.31
RFP-40-50TT	40	DC-3.0 GHz	1.25	4.5.33
RFP-50-50TCG	50	DC-2.0 GHz	1.30	4.5.35
RFP-50-50TCGR	50	DC-2.0 GHz	1.30	4.5.37
RFP-60-50TP	60	DC-6.0 GHz	1.25	4.5.39
RFP-60-50TPC	60	DC-6.0 GHz	1.25	4.5.41
RFP-60-50TPR	60	DC-6.0 GHz	1.25	4.5.43
RFP-100-50TW	100	DC-6.0 GHz	1.20	4.5.45
RFP-150-50TCGF	150	DC-2.0 GHz	1.30	4.5.47
RFP-150-50TAS	150	DC-2.0 GHz	1.35	4.5.49
RFP-150-50TG	150	DC-2.0 GHz	1.35	4.5.51
RFP-250-50TC	250	DC-3.0 GHz	1.30	4.5.53
RFP-400-50T	400	DC-500 MHz	1.30	4.5.55
RFP-800-50T	800	DC-500MHz	1.50	4.5.57

Terminations



RF Power

INTRODUCTION-

RF Power terminations are made as a thick film termination on a ceramic substrate. This allows for maximum flexibility when it comes to power handling and performance.

RESISTOR VALUE-

The standard resistor value is 50Ω, but a wide range of values is available upon request. Standard resistor value tolerance is 5%, but other tolerance values are available upon request.

VSWR-

All terminations have been optimized for low VSWR within the specified frequency band. The terminations will also work outside the specified frequency but with a higher VSWR. The specified VSWR for each termination is measured assuming that the recommended stress relief on the lead has been done.

POWER HANDLING-

To achieve the best possible power handling, all terminations in this section are made using Beryllium Oxide (BeO). BeO has a high thermal conductivity, allowing for excellent heat transfer from the resistor to the heat sink.

LEADS-

As a standard, all RF Power terminations come with 99.99% pure silver leads. This allows for excellent solderability and easy lead forming. Other types of leads are available upon request.

MOUNTING-

RF Power terminations are available in two mounting types. **Flangeless** allows for the best possible heat transfer to the heat sink. **Flanged** allows for easy assembly. It is important to follow the described mounting procedure for all types to achieve the best electrical and thermal performance.

PART NUMBERING-

Part numbers are composed in the following way:

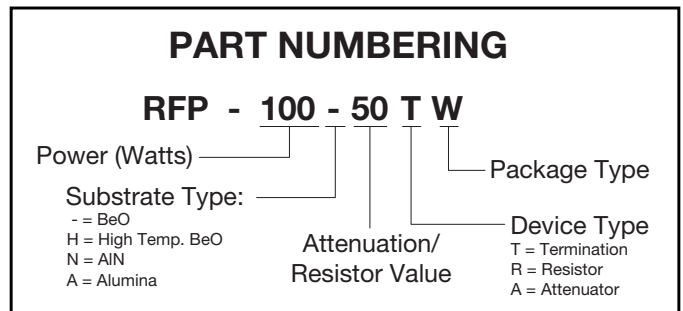

www.anaren.com

to locate data sheets and s-parameters

As a supplement to the standard flange mounted terminations, a special line of RF Power high temperature terminations are offered. These terminations have the same excellent electrical performance as the standard line, but have an extended operating temperature range. Below is a list of the high temperature terminations available. The page numbers refer to the electrically equivalent standard part.

Part Number	Power (Watts)	Frequency	VSWR Max: 1	Page
RFP-10H50TV	10	DC-4.0 GHz	1.25	4.5.17
RFP-10H50TVC	10	DC-4.0 GHz	1.25	4.5.19
RFP-10H50TVR	10	DC-4.0 GHz	1.25	4.5.21
RFP-10H50TVV	10	DC-4.0 GHz	1.25	4.5.23
RFP-20H50TP	20	DC-6.0 GHz	1.25	4.5.25
RFP-20H50TPC	20	DC-6.0 GHz	1.25	4.5.27
RFP-20H50TPR	20	DC-6.0 GHz	1.25	4.5.29
RFP-40H50TR	40	DC-3.0 GHz	1.25	4.5.31
RFP-40H50TT	40	DC-3.0 GHz	1.25	4.5.33
RFP-50H50TCG	50	DC-2.0 GHz	1.30	4.5.35
RFP-50H50TCGR	50	DC-2.0 GHz	1.30	4.5.37
RFP-60H50TP	60	DC-6.0 GHz	1.25	4.5.39
RFP-60H50TPC	60	DC-6.0 GHz	1.25	4.5.41
RFP-60H50TPR	60	DC-6.0 GHz	1.25	4.5.43
RFP-100H50TW	100	DC-6.0 GHz	1.20	4.5.45
RFP-150H50TCGF	150	DC-2.0 GHz	1.30	4.5.47
RFP-150H50TAS	150	DC-2.0 GHz	1.35	4.5.49
RFP-150H50TG	150	DC-2.0 GHz	1.35	4.5.51
RFP-250H50TC	250	DC-3.0 GHz	1.30	4.5.53

The power derating for this line of terminations has been extended from the standard 150°C to 250°C, allowing for the use of these high temperature terminations in thermally demanding applications.

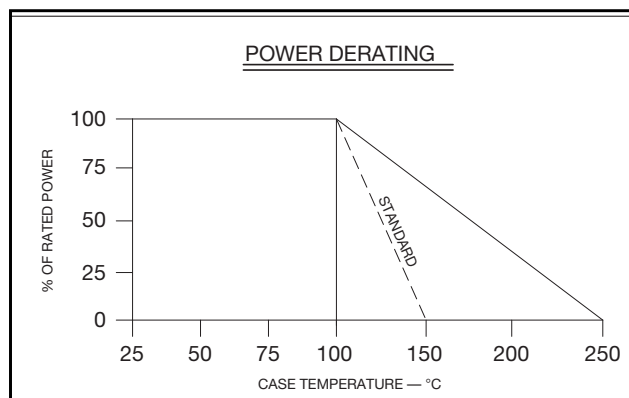

Terminations

Anaren

RF Power



www.anaren.com

to locate data sheets and s-parameters

