

## Anaren 0404 (BD2425N100ATI) balun optimized for Texas Instruments CC2530 Transceiver

Nithya R Subramanian – RF Engineer

Chong Mei – Senior RF Engineer

February 2nd, 2010

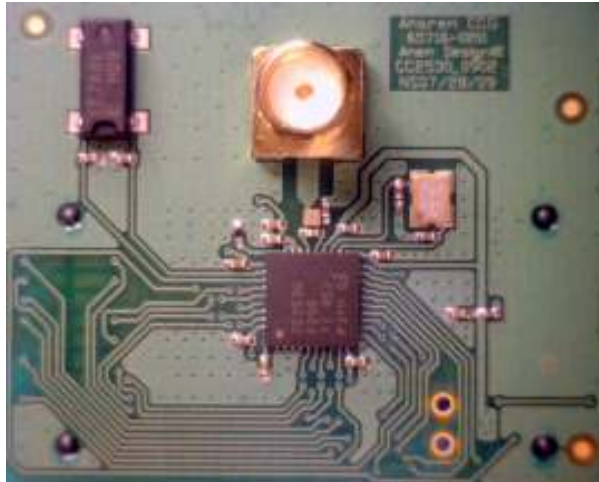

### Introduction

Over the last few years, the drive for miniaturization and integration has intensified the challenges concerning the trade off between repeatability, cost and time to market. The design must be robust enough to achieve good yields, but also have the lowest possible bill of material cost. The total cost not only depends on the number and types of parts and their associated cost, but also on the size of the PCB and enclosure.

At Anaren the focus is on developing products that address these trade-offs. Integrating 100% RF tested components increase yield and decreases size and time to market. The following application note demonstrates these objectives clearly as we present a small and simple balun solution optimized for use with Texas Instruments' CC2530 transceiver. The CC2530 is a true system-on-chip (SoC) solution for IEEE 802.15.4, Zigbee and RF4CE applications. The balun solution presented in this application note uses only three components: a 1mm square Anaren multilayer balun, a DC blocking capacitor and an inductor for impedance matching. This results in a solution that minimizes space and performs according to the specifications in the CC2530 data sheet.

The CC2530 combines the excellent performance of a leading RF transceiver with an industry-standard enhanced 8051 MCU, in-system programmable flash memory, 8-KB RAM, and many other powerful features. The CC2530 comes in four different flash versions: CC2530F32/64/128/256, with 32/64/128/256 KB of flash memory, respectively. The CC2530 is highly suited for systems where ultralow power consumption is required.

For more information about this or any other products currently available in the Anaren product portfolio, please visit our website at [www.anaren.com](http://www.anaren.com) for datasheets, S parameters and general corporate information.

For more information on Low Power Wireless products from Texas Instruments please visit [www.ti.com/lpw](http://www.ti.com/lpw)

## Comparisons of Different Balun Solutions

The RF front end for the CC2530 is architecturally simple in that both receiver LNA and transmitter PA are attached to the same set of balanced pins. Hence impedance matched, balanced to single ended transformation is all that is needed.

A multitude of possible balun implementations exist. Texas Instruments provides one such reference design which uses 7 discrete components in the current version and three 0404 sized pads left for tuning, so totally there are 10 discrete components in the reference solution. The solution from Anaren, described in this document, uses a discrete balun, one capacitor necessary for the DC blocking and one inductor for impedance matching. Below is a detailed comparison of the lumped element solution and the IC balun solution.

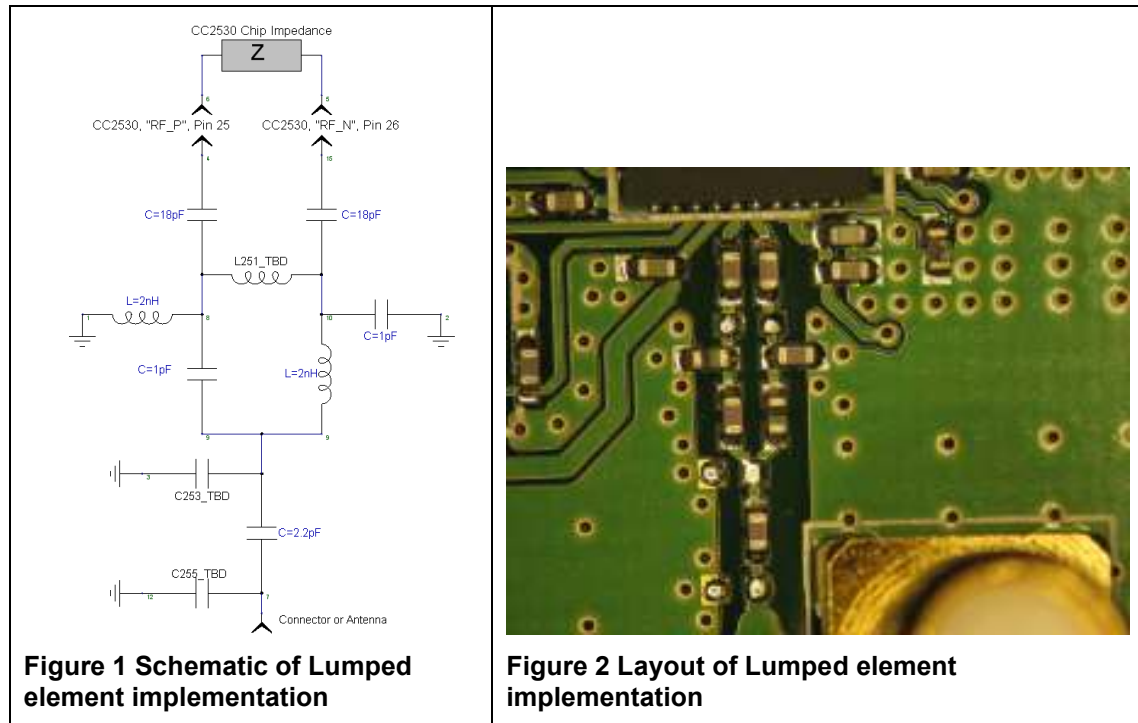

The lumped element implementation shown in Figure 1 and Figure 2 uses 5 to 7 capacitors and 2 to 3 inductors. However the PCB real estate taken up is significant and the performance is sensitive to changes in component vendor, component placement, PCB thickness and variation in the PCB material.

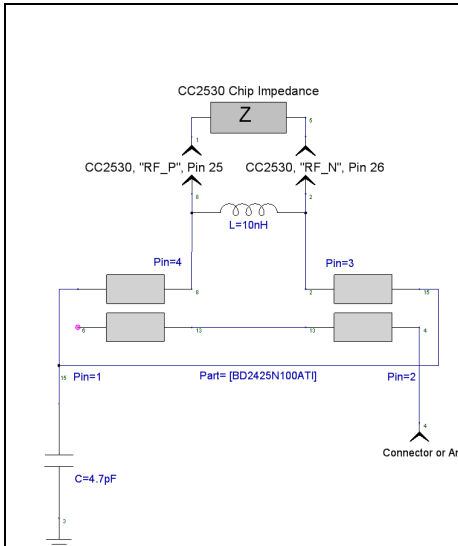

**Figure 3 Schematic of the Anaren balun implementation with 0201 matching components**

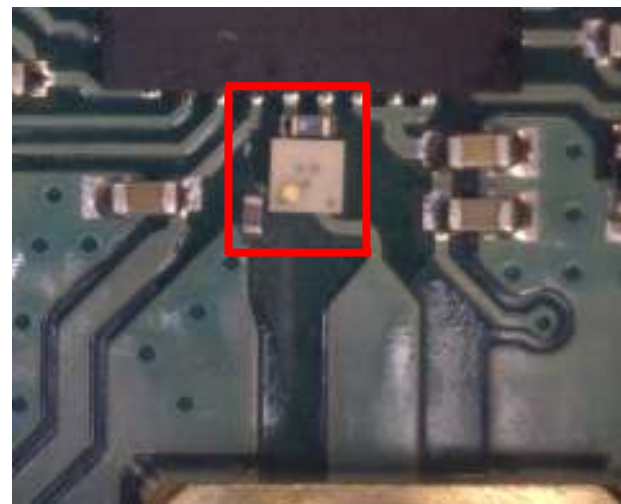

**Figure 4 Layout of the Anaren balun implementation with 0201 matching components**

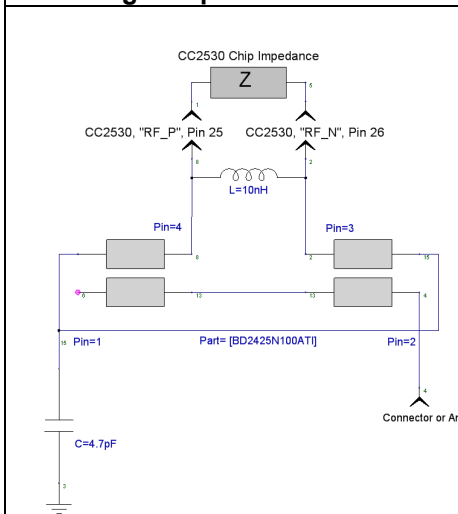

**Figure 5 Schematic of the Anaren balun implementation with 0402 matching components**

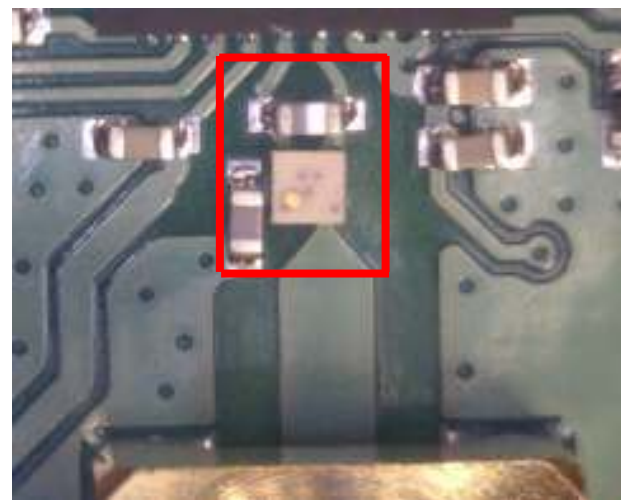

**Figure 6 Layout of the Anaren balun implementation with 0402 matching components**

The Anaren solutions shown in Figure 4 and Figure 6 take up significantly less PCB area and less number of external matching components which make them less susceptible to the discrete component tolerance/variation.

The recommended Anaren solutions are:

- BD2425N100ATI balun with 0201 matching components: 10nH (TDK MLK0603L10NJ) and 4.7pF (AVX 0201ZK4R7BBW)
- BD2425N100ATI balun with 0402 matching components: 10nH (TDK MLK1005S10NJT) and 4.7pF (ATC 600L4R7)

Table 1 demonstrates the significant reduction in size and component count achieved with the Anaren 0404 balun solution.

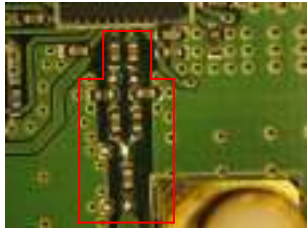
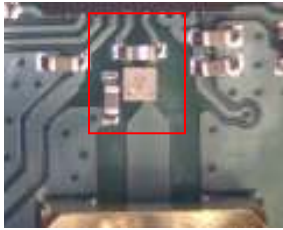
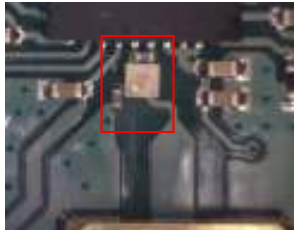
Solution	Lumped element design	Anaren balun 0402 matching components	Anaren balun 0201 matching components
			
Component Count and type	7 Total 5 Capacitors 2 Inductors	3 Total 1 Balun 1 Inductor 1 Capacitor	3 Total 1 Balun 1 Inductor 1 Capacitor
PCB Area	0.0215 sq. inch (0.546 sq.mm)	0.0059 sq inch (0.150 sq.mm)	0.0028 sq inch (0.071 sq.mm)
Space savings based on lumped element design	0%	73%	87%

**Table 1 Comparison of the three different implementations**

Care should be taken using alternate vendors especially on the inductor as they do not have the same performance. Each vendor of inductors and capacitors has their own way of realizing the parts with associated differences in parasitic values. Even within a single vendor, different component series are made differently, with significantly different parasitics. Also from one value to the next in the same series there can be parasitic differences. It is highly recommended to use the same parts as mentioned in this application note.

The Anaren recommended layouts with 0402 and 0201 matching components are fabricated on a 31.5mil (0.8mm) thick FR4 board. If a multilayer board is used it is recommended that internal power/GND planes be opened such that the effective height to GND is roughly 0.8mm, as illustrated in Figure 7. If it is not possible to open up internal layers then follow recommendations in Table 2 for changes to the transmission lines identified in Figure 8. The differential lines are identified with red arrows and the single ended connection identified with a blue arrow.

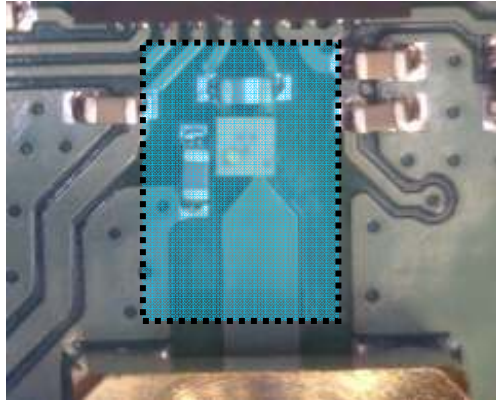

**Figure 7** Opening in power/GND planes below RF circuitry

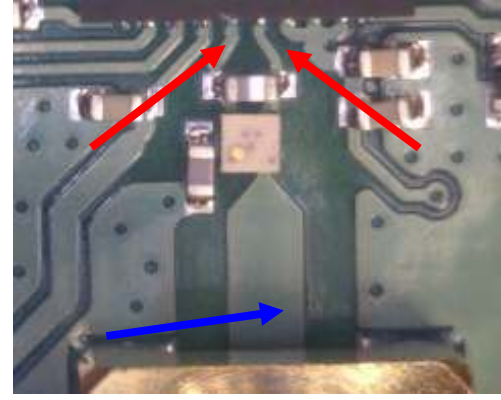

**Figure 8** Differential (red) connecting lines and single ended (blue) connecting line

Distance between ground and circuit layer mil (mm)	Differential line width Width/Length mil(mm)/mil(mm)	Single ended line width Width/Length mil(mm)/mil(mm)
5 (0.127), PI	8/33	20/255
8 (0.203), Ro4350	8/33	34/255
10 (0.254), FR4	8/33	37/255
20 (0.508), FR4	8/33	55/255
31.5 (0.699), FR4	8/36.6	55/255
40 (1.016), FR4	8/28	80/250
60 (1.524), FR4	8/25	112/197

**Table 2 : Differential line and single ended line width/length for various substrate heights based on Anaren 0404 balun with 0201 matching components**

The above mentioned line lengths and widths are for BD2425N100ATI Anaren balun with 0402 matching components only. The line length will change for Anaren balun with 0201 matching components. The values in table1 are simulated results only, except the row highlighted in green.

Changing the placement or value of the components and the dimensions of the PCB traces could affect the performance. It is therefore recommended to keep the DC block capacitor and the inductor for impedance matching close to the balun. The layout of the transmission lines connected to the balun should follow the recommendations in Table 2.

The value of the inductor and the capacitor also depends on the length of the transmission line used between the CC2530 chip and the balun. If the length of the transmission line between the chip and the balun is increased then the inductor and the capacitor values should be decreased and vice versa if the length of the line is decreased.

The SMA on the reference design can be replaced with an antenna or a different SMA connector. It is important in such cases to implement a 50 ohm trace between the balun and the antenna to achieve proper performance.

The lumped elements usually have 5% tolerance each and the discrete solution put together with 7 components will lead to very large variation in the performance but Anaren balun is consistent and tolerant to PCB manufacturing tolerances.

Production average and worst case data for the BD2425N100ATI are illustrated in Figure 9 Balun Performance

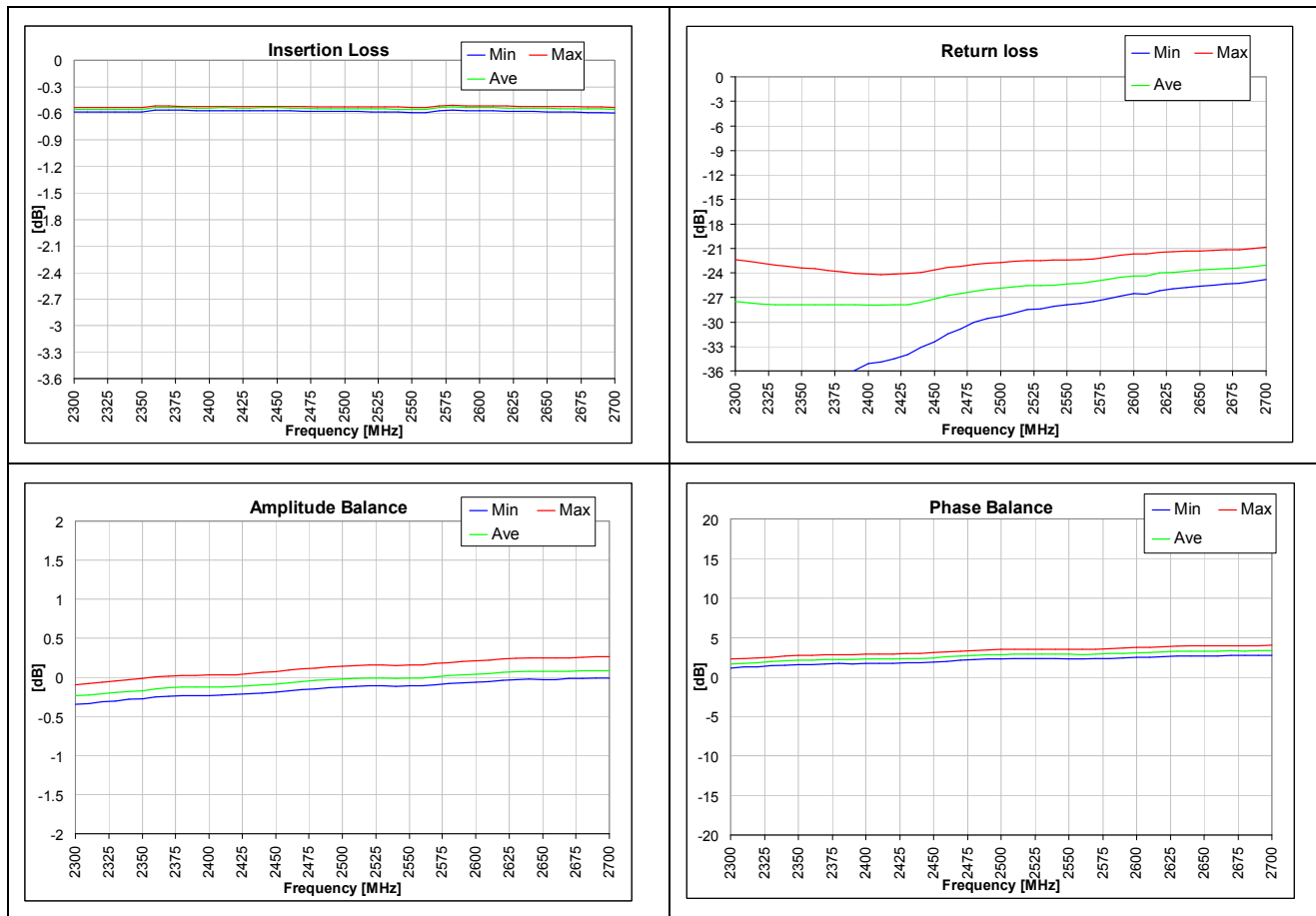

Figure 9 Balun Performance

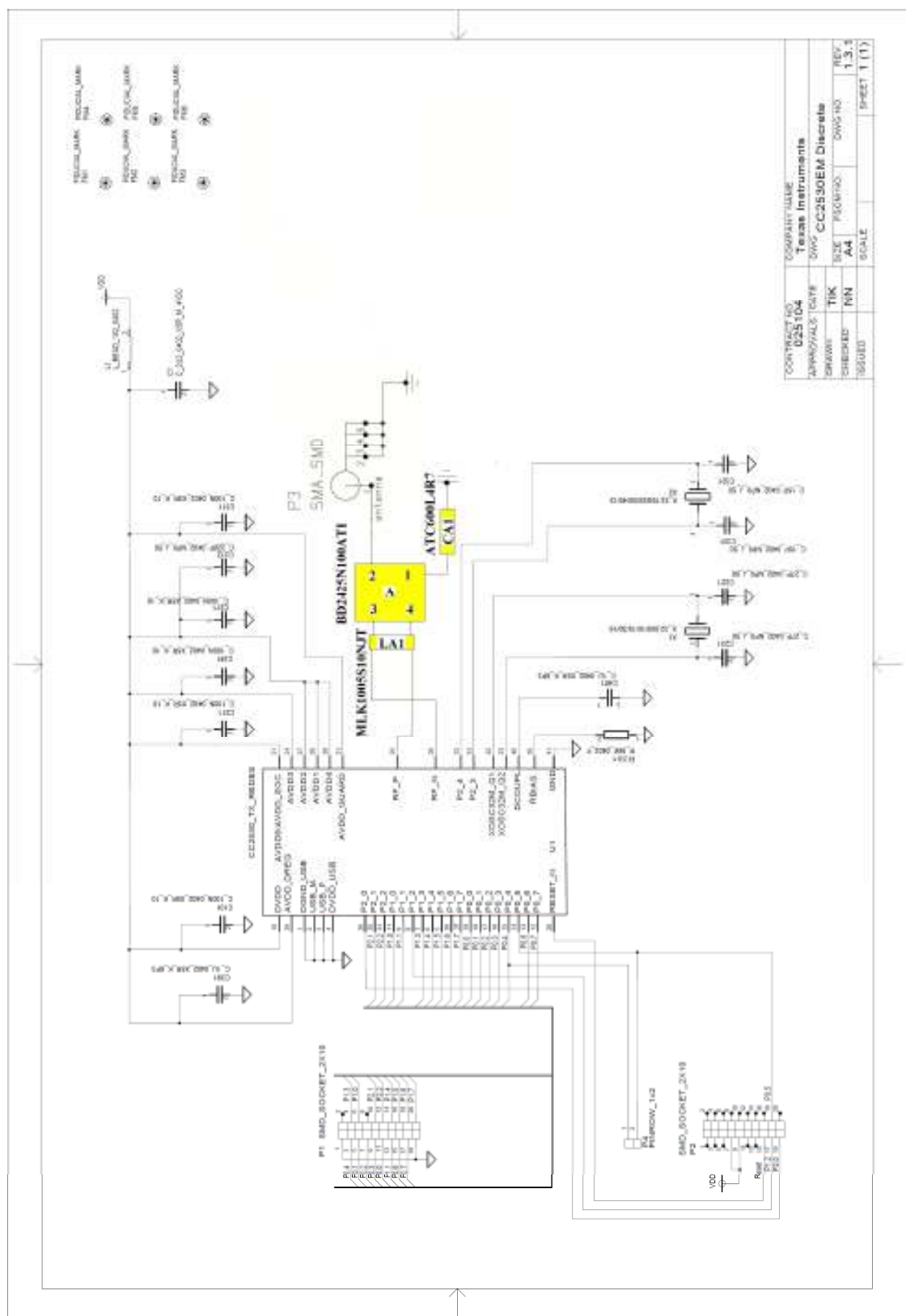

Figure 10 Evaluation daughter board schematic with the Anaren balun

Sales Desk USA: Voice: (800) 544-2414 Fax: (315) 432-9121  
 Sales Desk Europe: Voice: (+44) 2392 232392 Fax: (+44) 2392 251369

## Application Verification

Measurements verify that the reference design presented in this application note has the same performance as represented in the data sheet. These measurements include;

- Transmit Power
- Receive Sensitivity
- Harmonics

## Performance plots at 1dB power level selected at TI's RFstudio tool

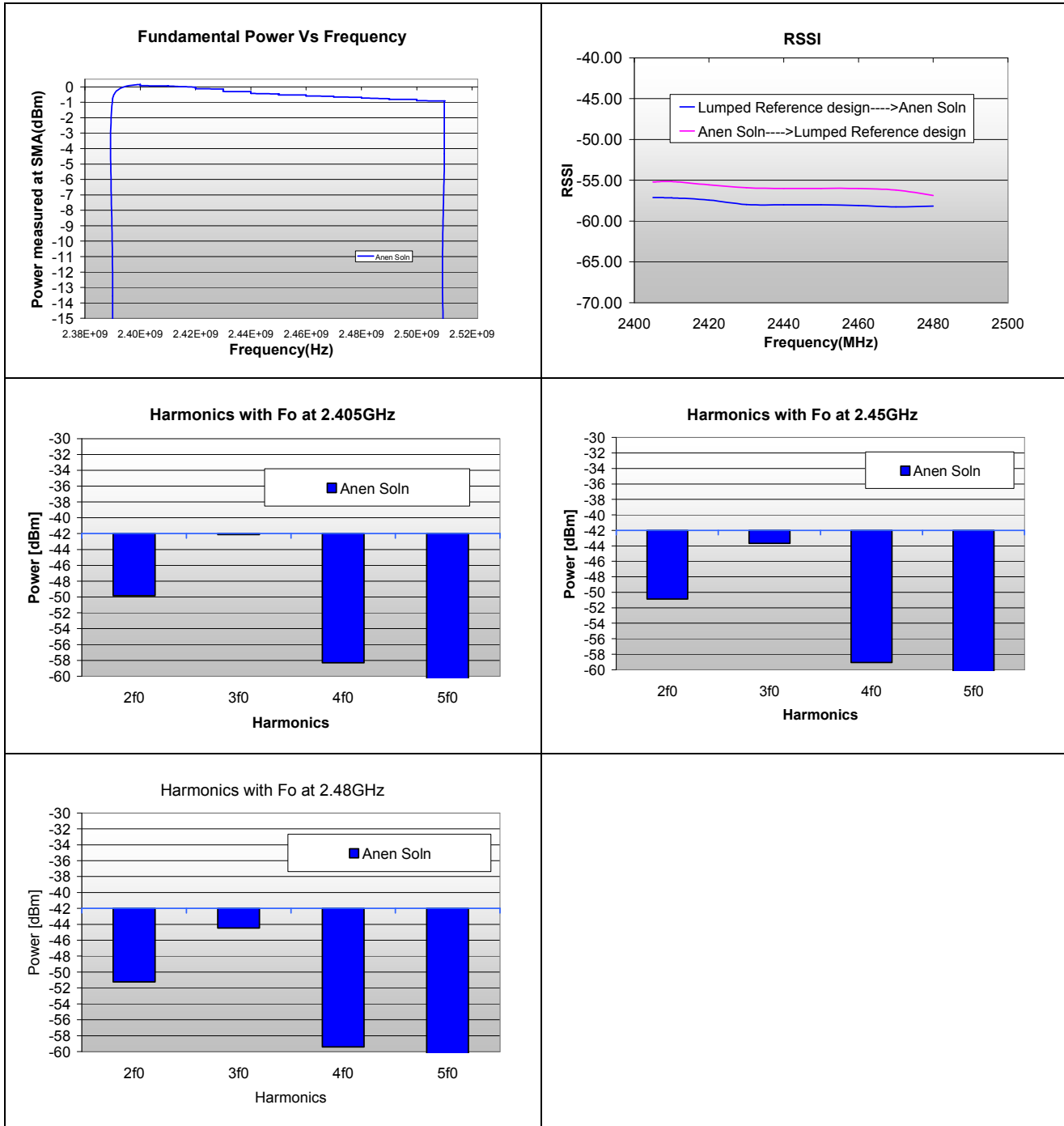

## References

1. <http://focus.ti.com/docs/prod/folders/print/cc2530.html> - CC2530EM Reference Design
2. <http://focus.ti.com/docs/prod/folders/print/cc2530.html> - CC2530 Development kit user manual

Please contact Anaren questions/enquiries or visit [www.anaren.com](http://www.anaren.com) for gerber files of the recommended layout.

<http://www.anaren.com/pages/index.cfm?id=162&page=appnotes>



## Ultra Low profile 0404 matched Balun for TI CC2530 chipset (Matched Impedance)

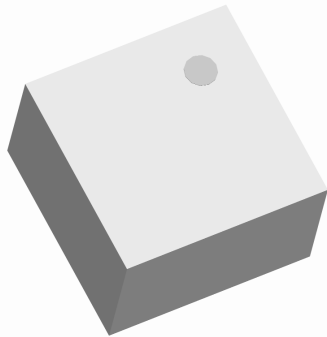

### Description

The BD2425N100ATI is a low cost, low profile sub-miniature unbalanced to balanced impedance matched transformer designed to interface directly to Texas Instruments CC2530 IEEE802.15.4 / RF4CE RFIC in an easy to use surface mount package. The BD2425N100ATI is ideal for high volume manufacturing and delivers higher performance than traditional ceramic baluns. This transformation enables single ended signals to be applied to the CC2530 differential ports. The output ports have equal amplitude (-3dB) with 180 degree phase differential. The BD2425N100ATI is available on tape and reel for pick and place high volume manufacturing.

**Detailed Electrical Specifications:** Specifications subject to change without notice.

Features:	Parameter	ROOM (25°C)			Unit
		Min.	Typ.	Max	
<ul style="list-style-type: none"> <li>• 2400 – 2500 MHz</li> <li>• ZigBee &amp; RF4CE ready</li> <li>• 0.65mm Height Profile</li> <li>• Low Insertion Loss</li> <li>• Surface Mountable</li> <li>• Tape &amp; Reel</li> <li>• Non-conductive Surface</li> <li>• RoHS Compliant</li> <li>• Halogen Free</li> </ul>	Frequency	2300		2600	MHz
	Unbalanced Port Impedance*		50		Ω
	Balanced Port Impedance*		MATCHED		Ω
	Return Loss*	17.3	23.6		dB
	Insertion Loss* **		0.68	0.84	dB
	Power Handling			1.0	Watts
	Operating Temperature	-55		+85	°C

\* Stated performance assumes proper matching network found in application note ANN-2004.

\*\* Insertion Loss stated at room temperature (Insertion Loss is approximately 0.1dB higher at +85°C)

### Outline Drawing

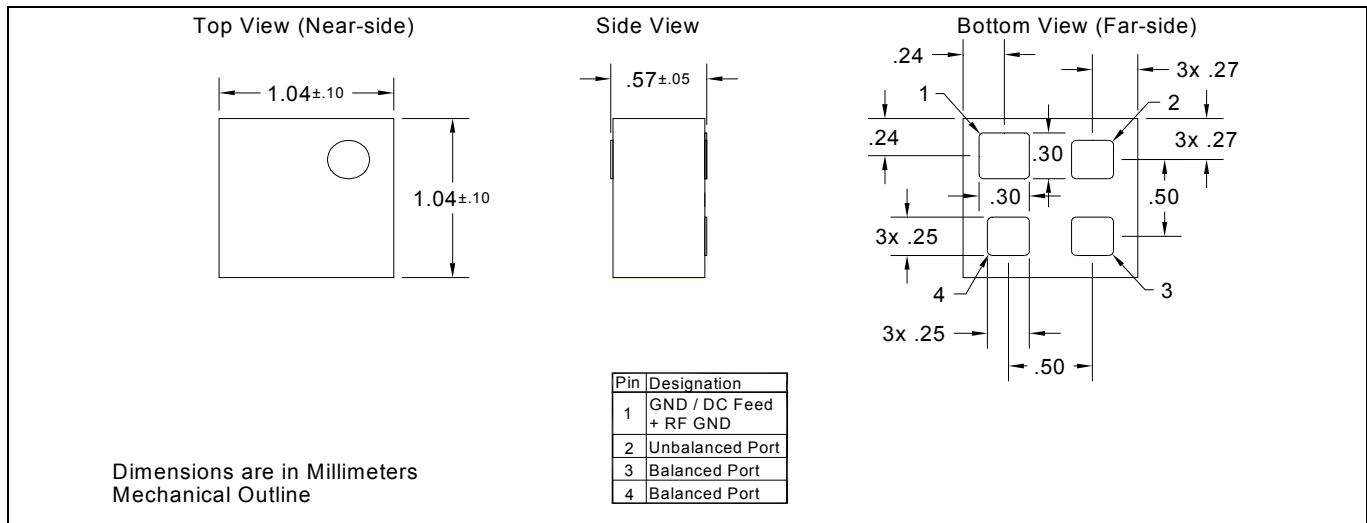

**Mounting Configuration:**

In order for Xinger surface mount components to work optimally, the proper impedance transmission lines must be used to connect to the RF ports. If this condition is not satisfied, insertion loss, Isolation and VSWR may not meet published specifications.

All of the Xinger components are constructed from organic PTFE based composites which possess excellent electrical and mechanical stability. Xinger components are compliant to a variety of ROHS and Green standards and ready for Pb-free soldering processes. Pads are Gold plated with a Nickel barrier.

An example of the PCB footprint used in the testing of these parts is shown below. In specific designs, the transmission line widths need to be adjusted to the unique dielectric coefficients and thicknesses as well as varying pick and place equipment tolerances.

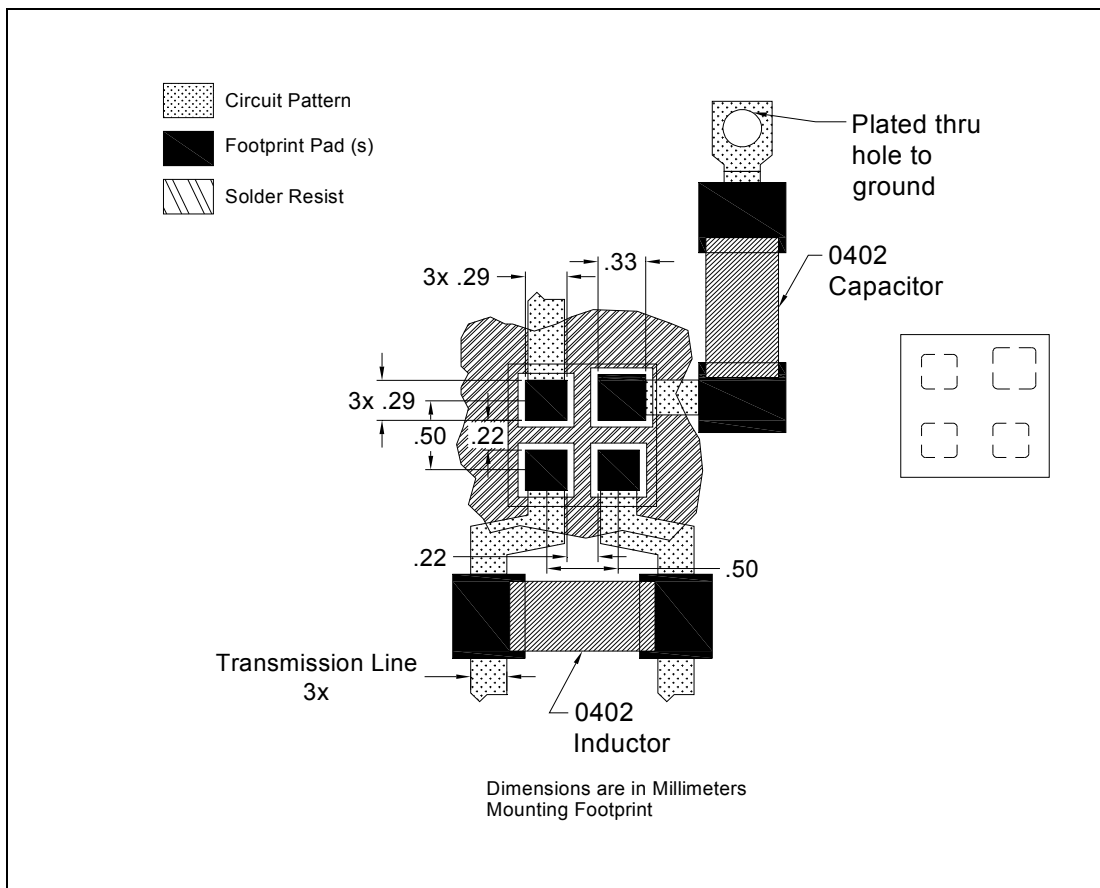

## Packaging and Ordering Information

Parts are available in reel and are packaged per EIA 481-2. Parts are oriented in tape and reel as shown below. Minimum order quantities are 4000 per reel. See Model Numbers below for further ordering information.

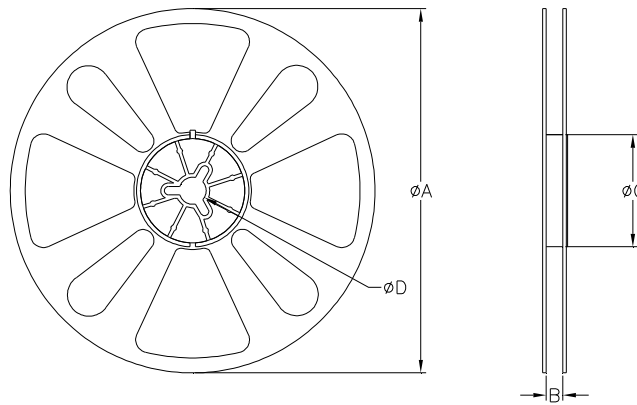
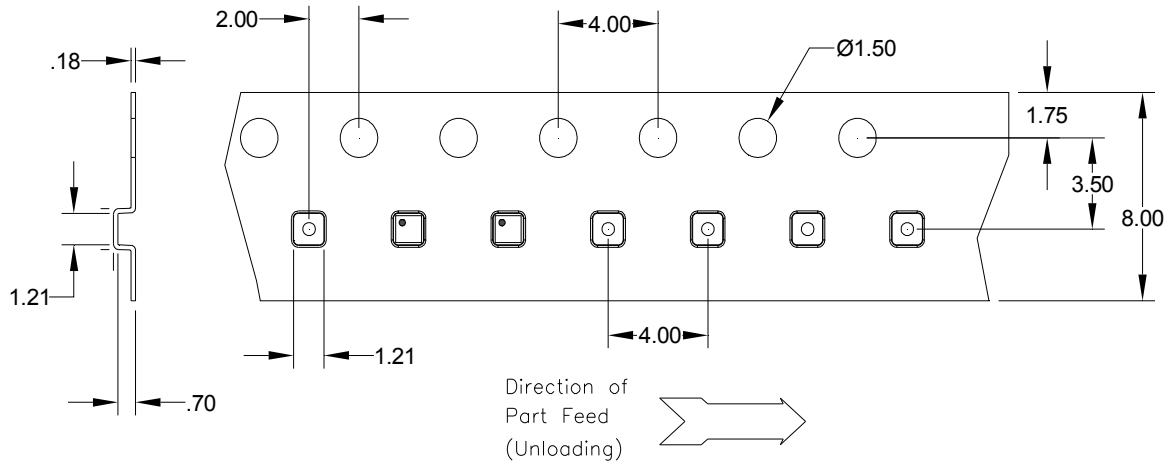

TABLE 1		
QUANTITY/REEL	REEL DIMENSIONS mm	
4000	ØA	177.80
	B	8.00
	ØC	50.80
	ØD	13.00