

Anaren 0404 (BD2425N50200A00) balun optimized for Texas Instruments CC2430 Transceiver

Nithya R Subramanian – RF Development Engineer

Niels Kirkeby– R&D Manager

August 31st, 2007

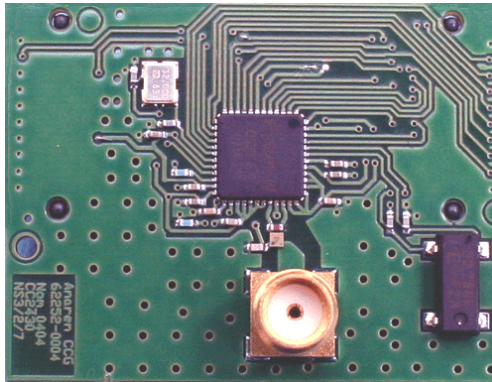

Introduction

Over the last few years, the drive for miniaturization and integration has intensified the challenges concerning the trade off between repeatability, cost and time to market. The design must be robust enough to get good yields, but also have the lowest possible bill of material cost. The total cost not only depends on the number and types of parts and their associated cost, but also on the size of the PCB and enclosure.

At Anaren the focus is on developing product that addresses this trade off. Integrating 100% RF tested components increase yield and decreases size and time to market. The following application note demonstrates these objectives clearly as we present a small and simple balun solution optimized for use with the CC2430 from Texas Instruments. The CC2430 is a true single-chip 2.4 GHz ISM and IEEE 802.15.4 (ZigBee) compliant RF transceiver, designed for low-power wireless applications. The reference design presented in this application note uses only three components for impedance matching: a 1mm square Anaren multilayer balun, a DC blocking capacitor and an inductor for final impedance matching. This results in a design which takes up very little space and performs according to the numbers in the CC2430 data sheet.

The CC2430 is a low-cost, highly integrated solution for robust wireless communication in the 2.4 GHz unlicensed ISM band. CC2430 is designed to be compliant with SRD regulations covered by ETSI EN 300 328 and EN 300 440 class 2 (Europe), FCC CFR47 Part 15 (US) and ARIB STD-T66 (Japan). The CC2430 provides extensive hardware support for packet handling, data buffering, burst transmissions, data encryption, data authentication, clear channel assessment, link quality indication and packet timing information.

For more information about this or any other products currently available in the Anaren product portfolio, please visit our website at www.anaren.com for datasheets, S parameters and general corporate information.

For more information on Low Power Wireless Zig products from Texas Instruments please visit www.ti.com/lpw for product information.

Comparisons of Different Balun Solutions

The RF front end for the CC2430 is architecturally simple in that both receiver LNA and transmitter PA are attached to the same set of balanced pins. The transmitter is linear enough to not require any significant filtering. Hence an impedance matched, balanced to single ended transformation is all that is needed. The only complication being that the PA bias power, pin 7 on the CC2430, needs to be supplied into the balanced pin set.

A multitude of possible balun implementations exist and Texas Instruments provides one such reference design. It uses a 180° transmission line and 4 discrete components. The solution from Anaren, described in this document, uses a discrete balun, one capacitor and one inductor.

Below we will step through each implementation to detail the differences and benefits that each offer.

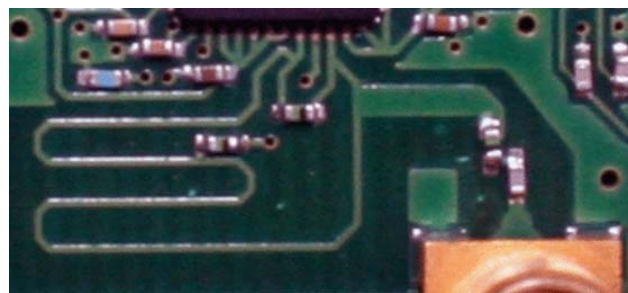
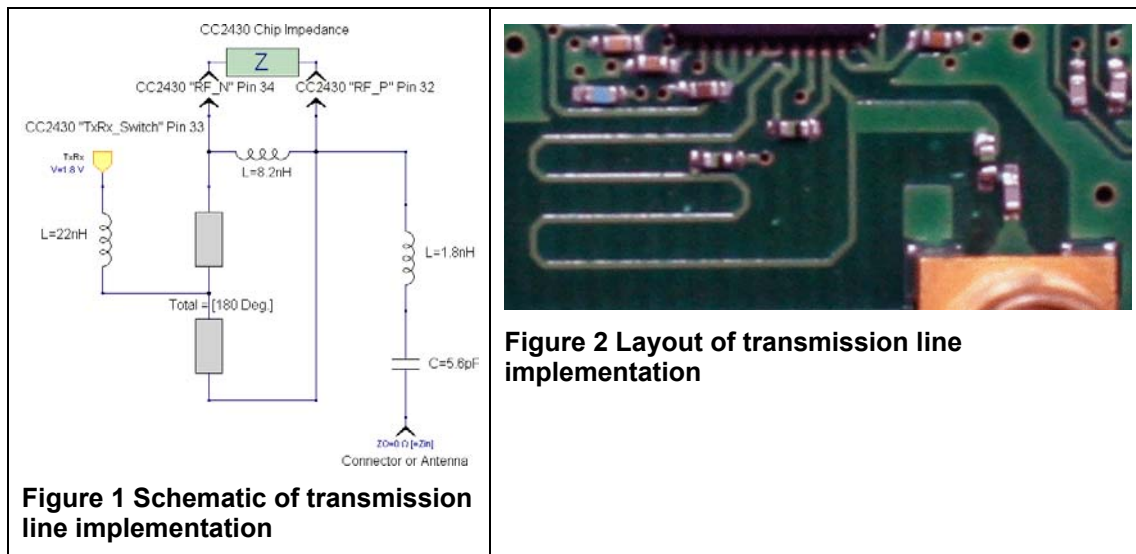
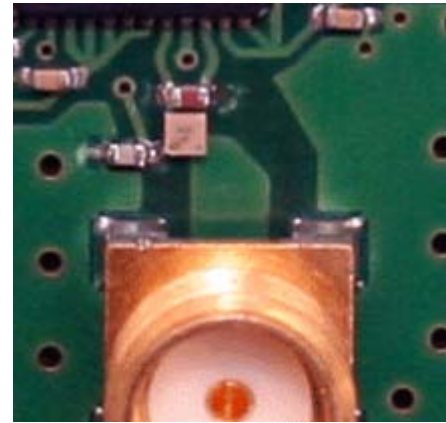
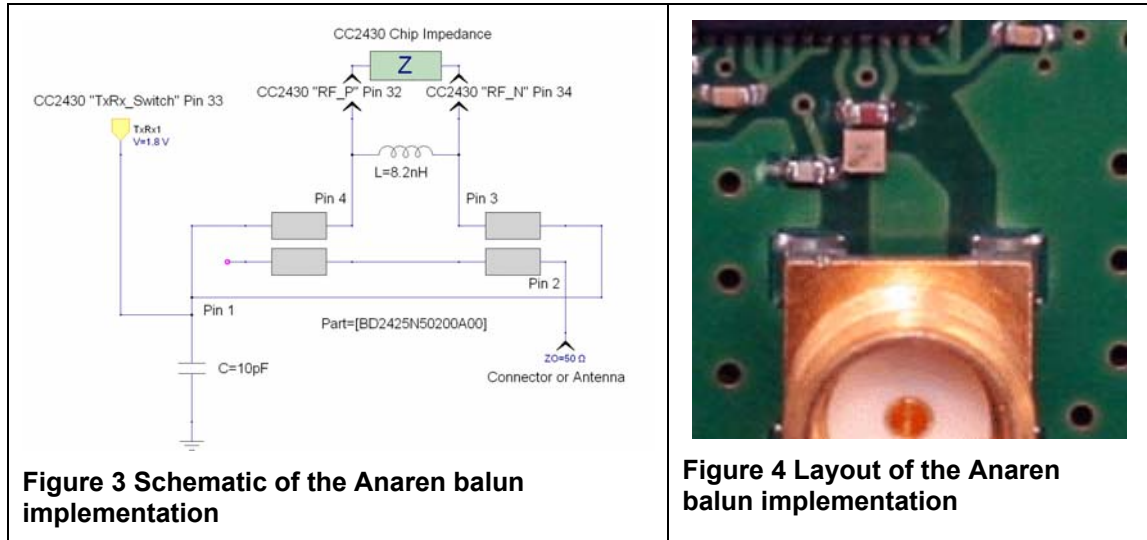

Figure 2 Layout of transmission line implementation

The transmission line implementation shown in Figure 1 and Figure 2 is straight forward and employs only four discrete components. However the PCB real estate taken up is significant and the performance is sensitive to changes of line width of the 180° transmission line, PCB thickness and variation in the PCB material.



The Anaren balun implementation shown in Figure 5 and Figure 6 has fewer components and uses less real estate than the other implementations.

The Anaren balun solution shown in Figure 5 and Figure 6 takes up even less PCB area and has reduced sensitivity to discrete component tolerance/variation.

Three different sets of matching components are recommended

- BD2425N50200A balun with 8.2nH (CLC inductor 0402CS-8N2XGL) and 10pF (DLI C04UL100J6S)
- BD2425N50200A balun with 5.6nH (CLC inductor 0402CS-5N6XGL) and 10pF (DLI C04UL100J6S)
- BD2425N50200A balun with 5.6nH (Johanson inductor L-07C5N6J) and 15pF (Johanson 250r07C150JV4)

Care should be taken using alternate vendors especially on the inductor as they do not have the same performance. Each vendor of inductors and capacitors has their own way of realizing the inductor/capacitor with associated differences in parasitic values, even within a single vendor, different component series are made differently with significantly different parasitics. Even from one value to the next in the same series there can be parasitic differences, if for instance a spiral inductor requires another turn to fit in the same footprint from one value to the next then either the trace width drops, another trace layer is used or maybe a different material set – these, from a value point of view, subtle changes causes significant parasitic change. If the change in impedance caused by parasitic changes falls within the circle outlined in Figure 8 the performance will be acceptable. One way to evaluate alternate vendors is to compare s-parameters of the components – however the s-parameters must be measured the same way from both vendors to be able to compare and this information is not often available. Another way is to use vendor or third party models but it is still important to know what each model represents; does it include the PCB pads, is the model valid for the PCB used etc.

The Anaren recommended layout (can be supplied as Gerber files) is fabricated on a 39mil thick FR4 board. If a multilayer board is used it is recommended that internal power/GND planes be opened such that the effective height to GND is roughly 40mil, as illustrated in Figure 5 below. If it is not possible in the application to open up internal GND planes then follow Table 1 for changes to the differential connecting lines, identified in Figure 6, with red

arrows and the single ended connection identified in Figure 6, with a blue arrow.

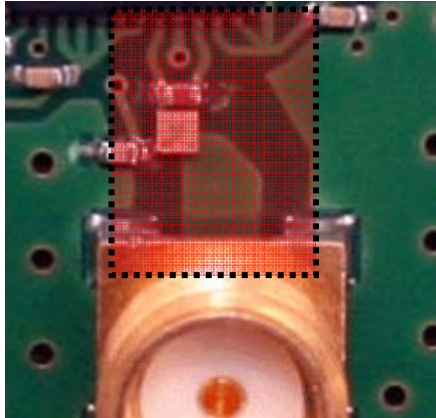

Figure 5 Opening in power/GND planes below RF circuitry

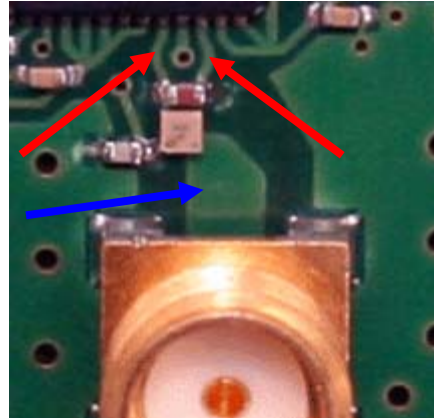

Figure 6 Differential (red) connecting lines and single ended (blue) connecting line

Distance to ground & material [mil,]	Differential line width Width/Length [mil/mil]	Single ended line width Width/Length [mil/mil]
5, PI	8/82	8/221
8, Ro4350	8/82	10/221
10, FR4	10/82	12/221
20, FR4	10/82	25/221
30, FR4	10/82	48/221
39, FR4	10/82	80/221
60, FR4	10/82	80/221

Table 1 : Differential line and single ended line width/length for various substrate heights

If a SMA connector is used and a GND plane spacing other than 39mil is used, then the launch area must be opened or otherwise compensated to provide proper match.

If the location of the components is changed (not recommended) then it is very important to keep the DC blocking capacitor very close to the balun (pin 1). Also the trace lines between the CC2430 chip, the parallel inductor and balun are an integral part of the matching and should not be changed in length.

Table 2 demonstrates the significant reduction in size and component count board layout achieved with the Anaren 0404 balun solution.

Solution	Transmission line design	Anaren/TI 0404 internal bias solution
Component Count and type	4 Total 1 Capacitor 3 Inductors	3 Total 1 Balun 1 Inductor 1 Capacitor
PCB Area	0.1448 sq. inch	0.0174 sq inch
Space savings based on lumped element design	0%	88%

Table 2 Comparison of the three different balun implementations

The Anaren balun performance is consistent and tolerant to PCB manufacturing tolerances. Production average and worst case data for the BD2425N50200A00 are illustrated in Table 3.

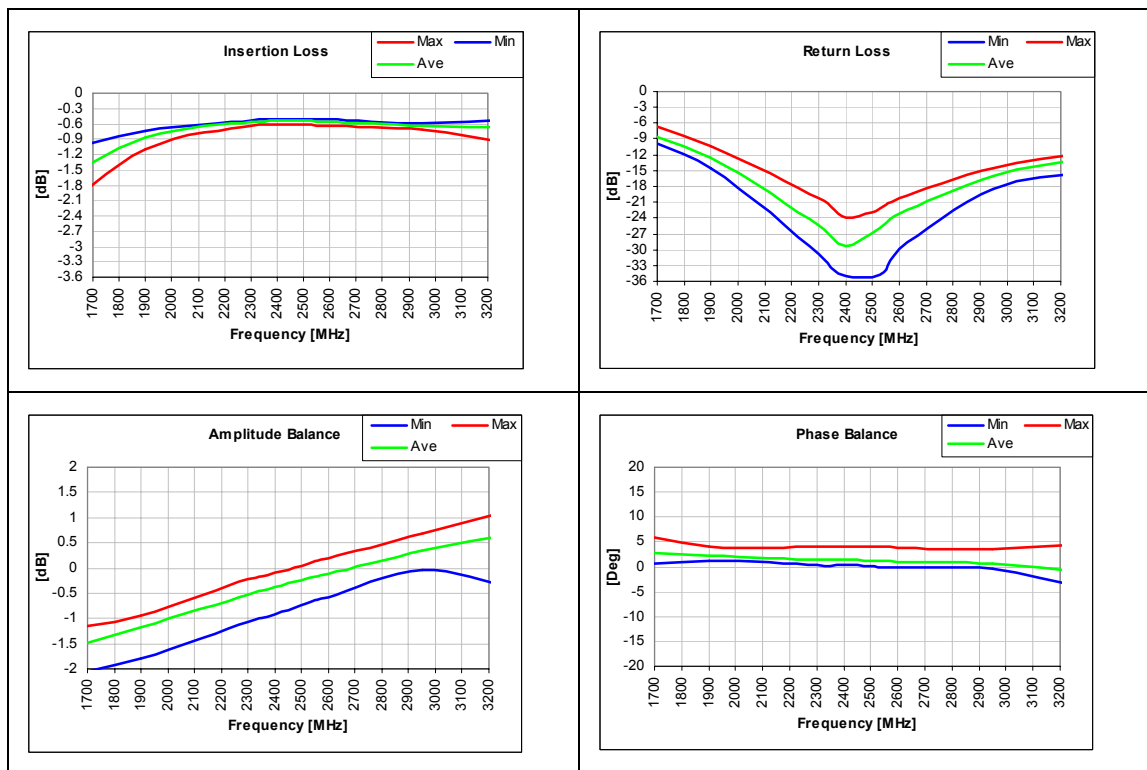
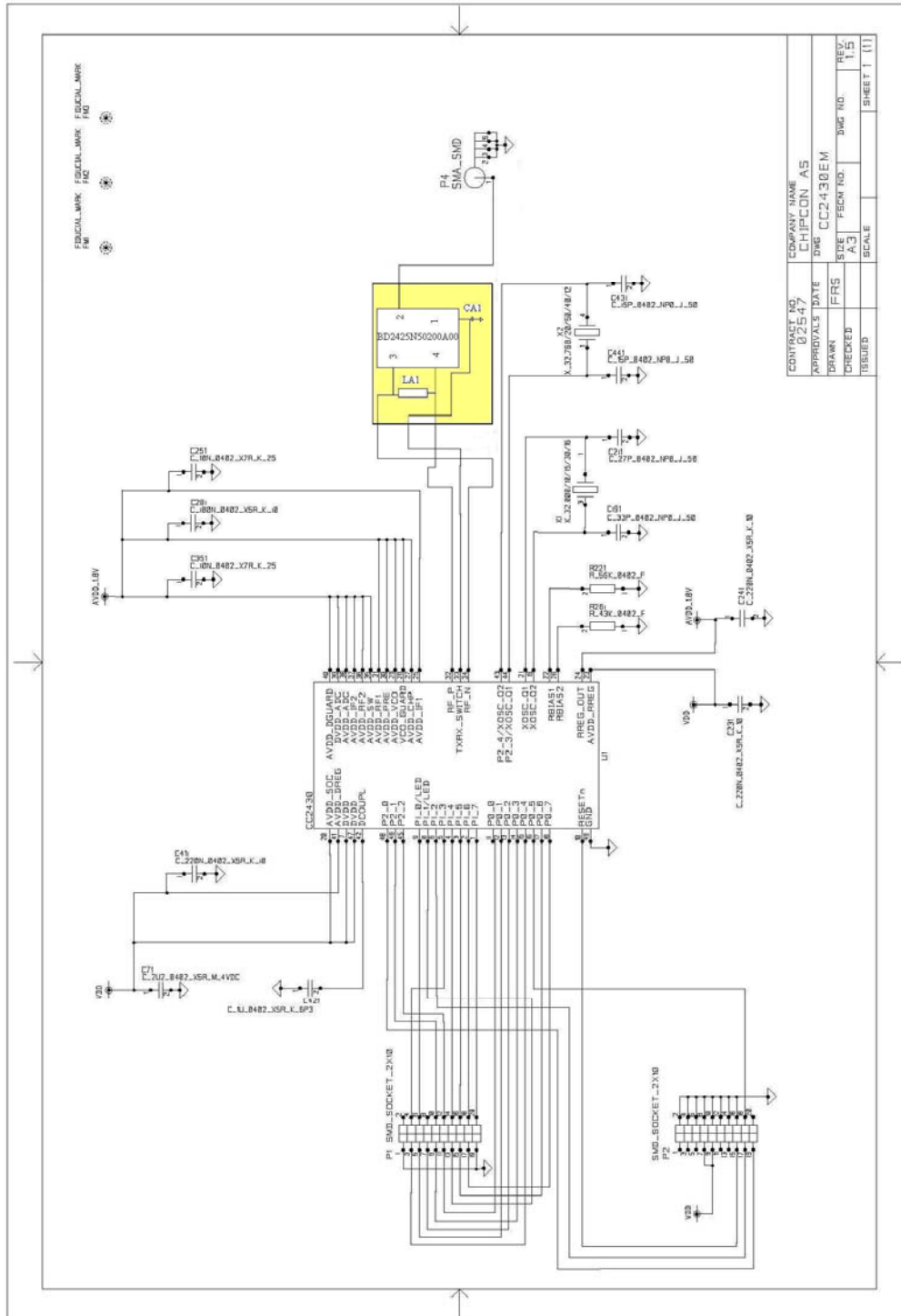

Table 3 Balun Performance



CONTRACT NO.	COMPANY NAME
DATE	CHIPCON AS
APPROVALS DATE	DWG CC2-430EM
DRAWN	SIZE
CHECKED	FECD NO.
ISSUED	SCALE
	SHEET 1 (1)

Figure 7 Evaluation daughter board schematic with the Anaren balun

Application Verification

Measurements verify that the reference design presented in this application note has the same performance as represented in the data sheet. These measurements include;

- Transmit Power
- Receive Sensitivity
- Current consumption

These measurements were performed independently by both Anaren and TI. In addition TI also performed an Error Vector Magnitude measurement. Through further testing at Anaren the optimum impedance for the CC2430 Chip is found to be inside the range (ellipse) shown in Smith chart below.

Impedance between chip and balun

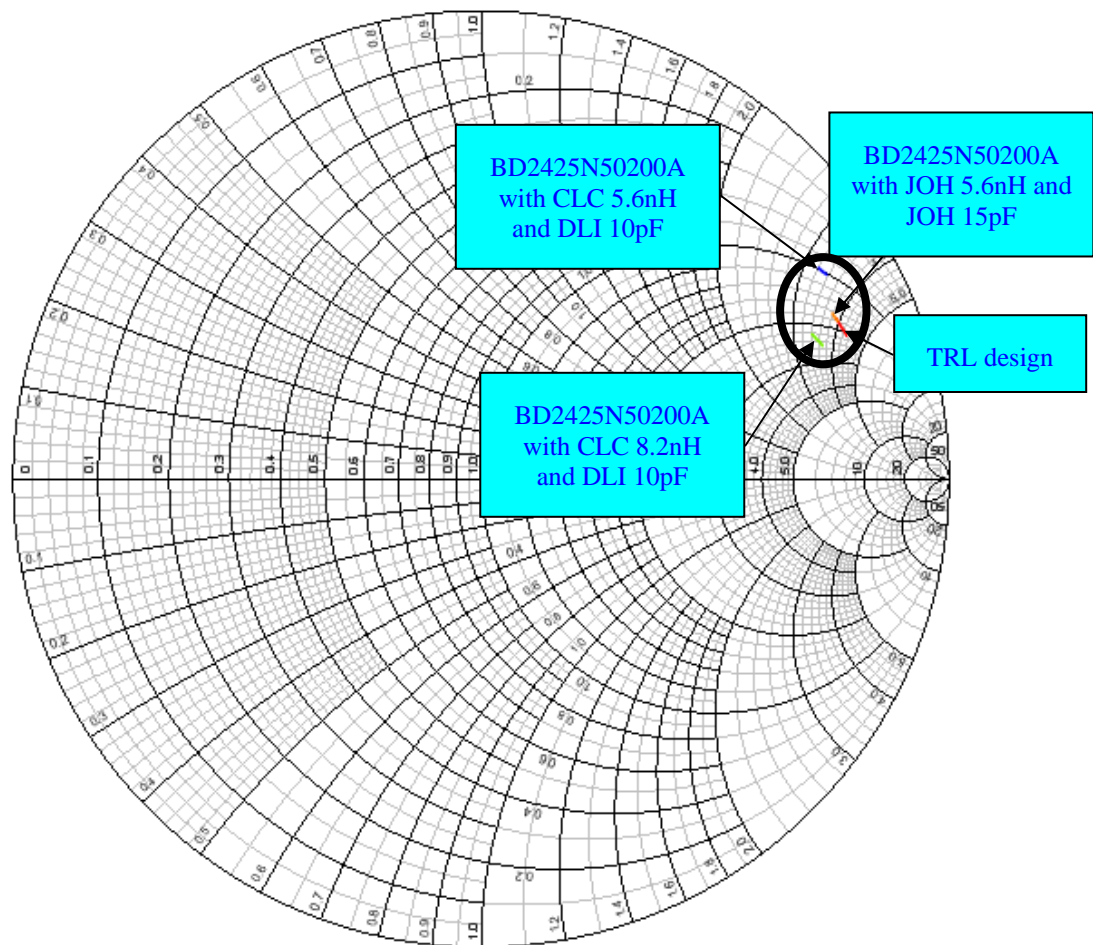

Figure 8 Anaren balun matching impedances

The Impedance Matching

In the following a description is offered on the impedance matching steps and guidance for deviations if needed.

Optimum differential impedance as seen from the RF ports towards antenna is stated as $60+j164 \Omega$ in the data sheet for the CC2430. The BD2425N50200A balun has 50Ω single ended port impedance and 200Ω balanced port impedance. An 8.2nH inductor is connected across the balanced ports for matching purposes and a 10pF capacitor is used at pin 1 as a DC block (RF GND) to allow biasing through this pin to the differential ports, pin 3 and pin 4 of the balun. This is illustrated in Figure 9.

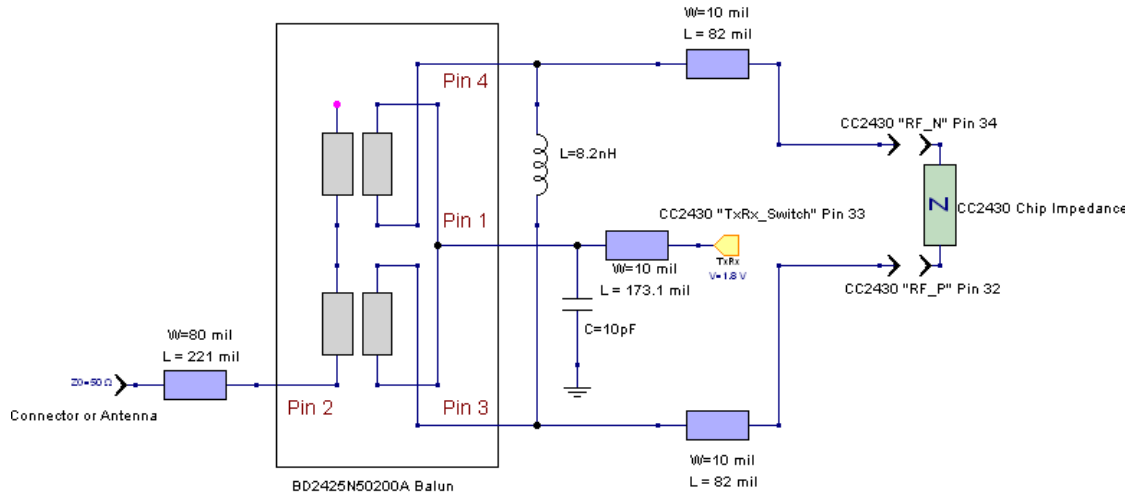

Figure 9 Anaren balun schematic

The impedance matching steps, with a SMA connector illustrated in the smith chart in Figure 10 performs the match as follows.

- The connector and the connecting line at the input transform 50Ω to $45-j2 \Omega$. (Note1).
- The balun transforms $45-j2 \Omega$ into $239+j29 \Omega$
- The inductor at the differential arm of the balun brings the impedance to $69+j109 \Omega$
- The transmission line to interface the chip to the balun brings the impedance to $91+j162 \Omega$.
- The DC-blocking capacitor and transmission line from the Tx/Rx switch to the bias point of the balun (pin 1) transforms the impedance to $88+j191 \Omega$

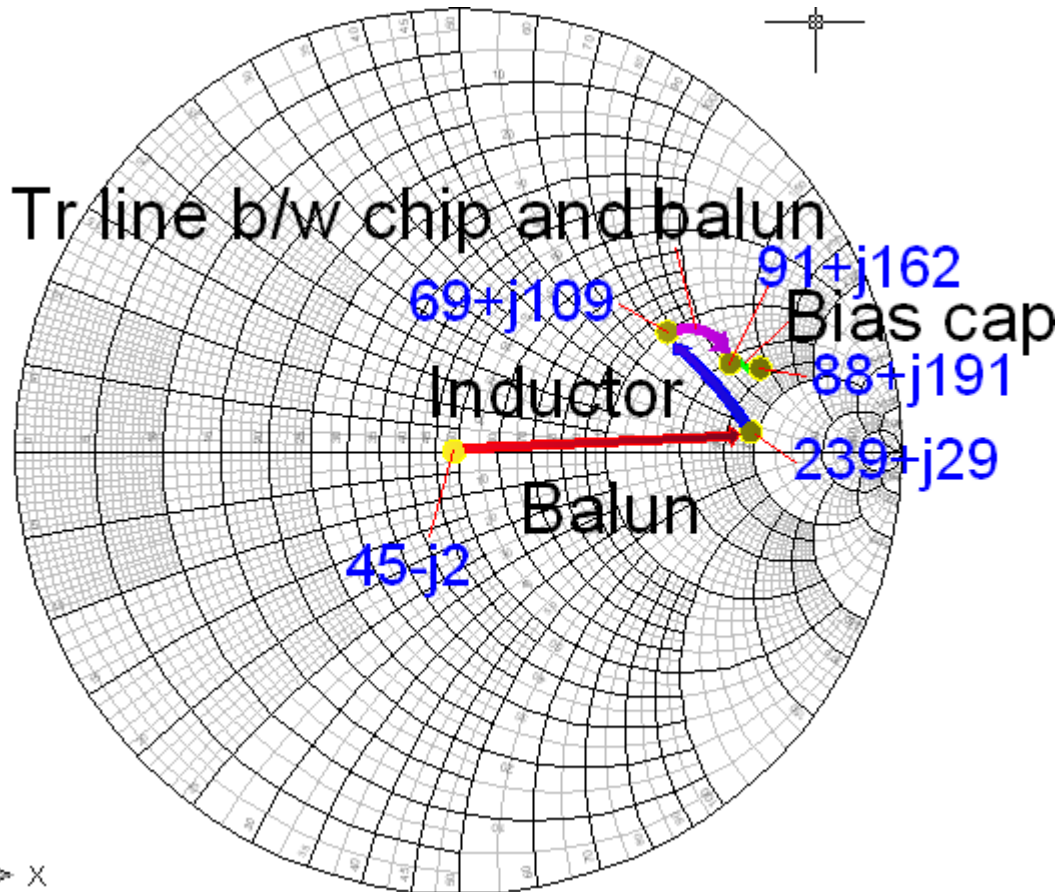

Figure 10 Smith chart showing the impedance matching steps

The value of the inductor and the capacitor also depends on the length of the transmission line used between the CC2430 chip and the balun. If the length of the transmission line between chip and the balun is increased then the inductor and the capacitor values should be decreased. If the length of the line is decreased then the inductor and capacitor should be increased.

It is strongly recommended to use the same line length, width, inductor and capacitor values as shown in the 0404 internal bias design schematic. Any change in inductor value, DC-blocking capacitor value or layout will give only similar but not exactly the same performance.

Note 1: If a SMA connector is not used then a 50 Ω transmission line should be used to connect to the balun, this change will cause a negligible shift in performance

References

1. <http://focus.ti.com/docs/prod/folders/print/cc2430.html> - CC2430EM Reference Design
2. <http://focus.ti.com/docs/prod/folders/print/cc2430.html> - CC2430 Development kit user manual



Ultra Low Profile 0404 Balun 50Ω to 200Ω Balanced

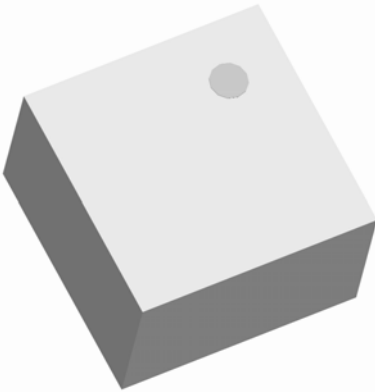

Description

The BD2425N50200A00 is a low cost, low profile sub-miniature unbalanced to balanced transformer designed for differential inputs and output locations on modern chipsets in an easy to use surface mount package. The BD2425N50200A00 is ideal for high volume manufacturing and delivers higher performance than traditional ceramic baluns. The BD2425N50200A00 has an unbalanced port impedance of 50Ω and a 200Ω balanced port impedance. This transformation enables single ended signals to be applied to differential ports on modern integrated chipsets. The output ports have equal amplitude (-3dB) with 180 degree phase differential. The BD2425N50200A00 is available on tape and reel for pick and place high volume manufacturing.

Detailed Electrical Specifications: Specifications subject to change without notice.

Features:	Parameter	ROOM (25°C)			Unit
		Min.	Typ.	Max	
<ul style="list-style-type: none"> • 2400 – 2500 MHz • 0.65mm Height Profile • 50 Ohm to 2 x 100 Ohm • Low Insertion Loss • 802.11 b+g • MIMO b+g • Bluetooth • Zigbee • Surface Mountable • Tape & Reel • Non-conductive • RoHS Compliant 	Frequency	2400		2500	MHz
	Unbalanced Port Impedance		50		Ω
	Balanced Port Impedance		200		Ω
	Return Loss	21	27		dB
	Insertion Loss*		0.6	0.7	dB
	Amplitude Balance		0.5	1.0	dB
	Phase Balance		2	6	Degrees
	CMRR		29		dB
	Power Handling			1	Watts
	Operating Temperature	-55		+85	°C

* Insertion Loss stated at room temperature (Insertion Loss is approximately 0.1 dB higher at +85 °C)

Outline Drawing

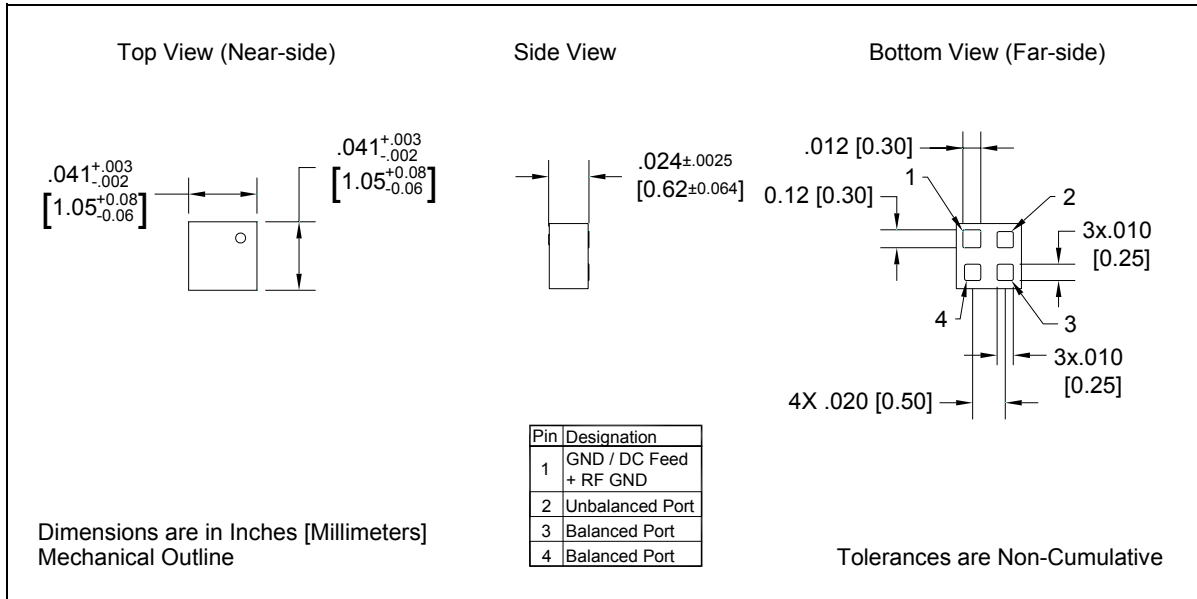

Typical Performance: 2400 MHz. to 2500 MHz.

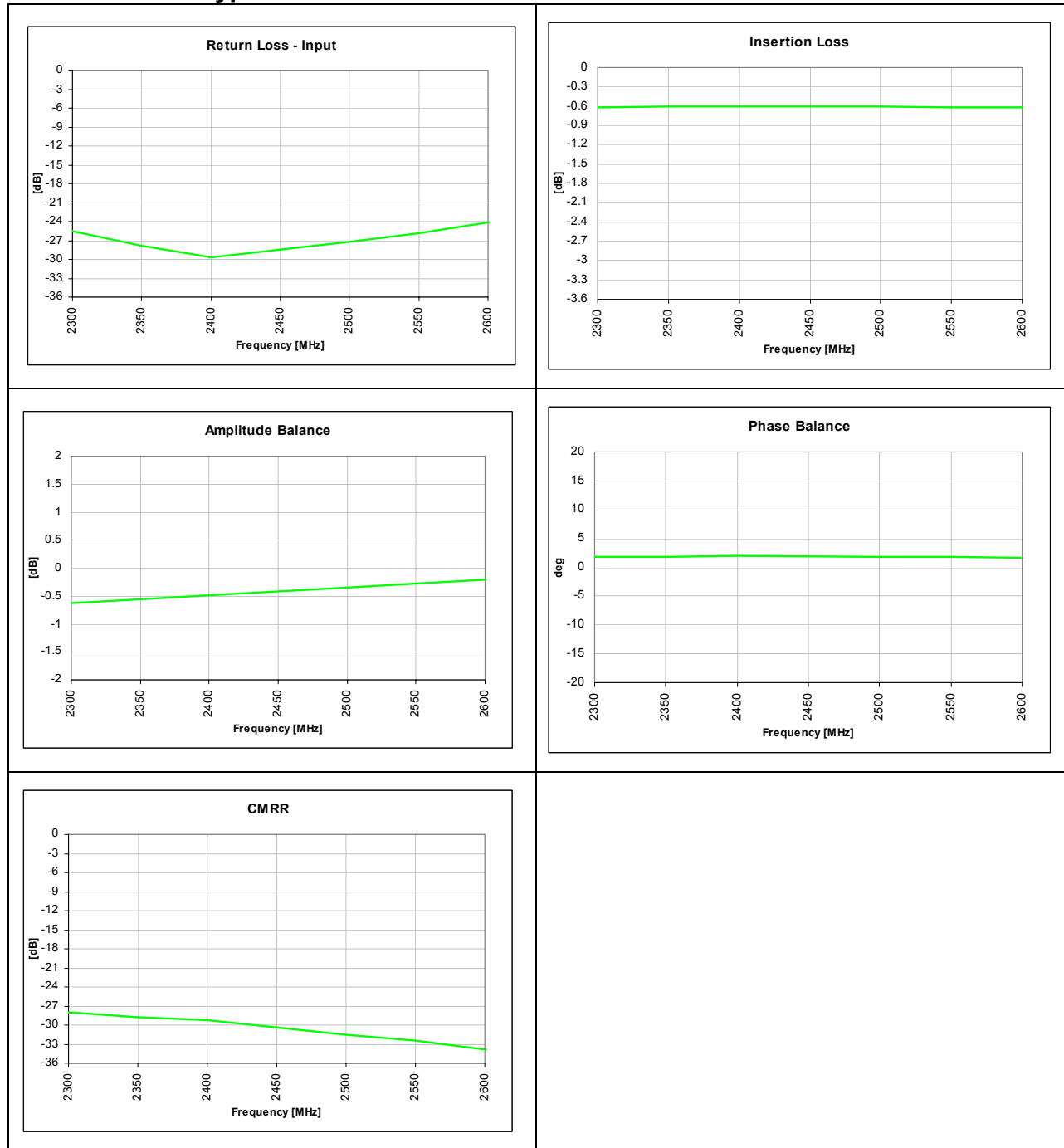

Wide Band Performance: 500 MHz. to 8500 MHz.

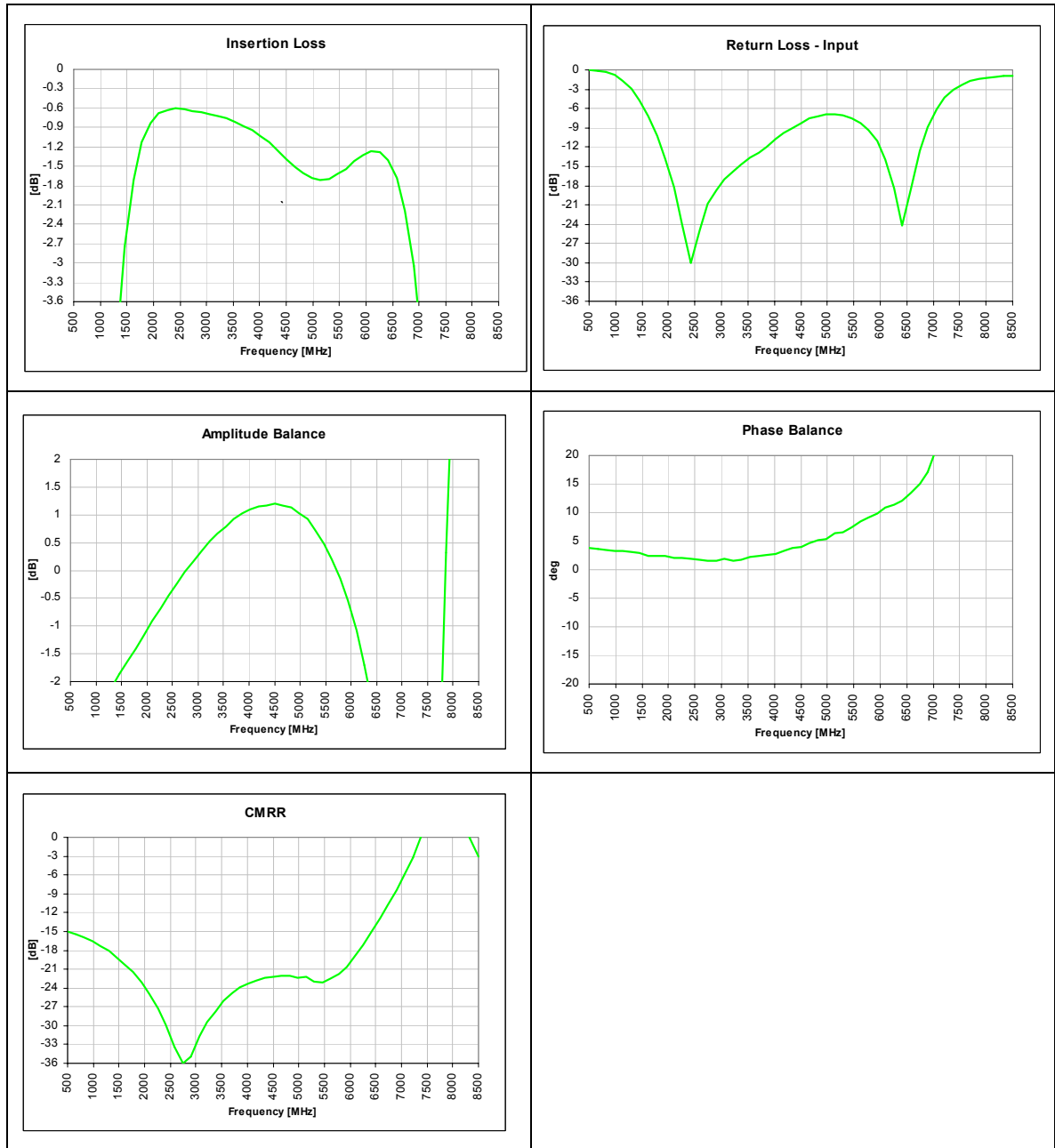

Sales Desk USA: Voice: (800) 544-2414 Fax: (315) 432-9121

Sales Desk Europe: Voice: (+44) 2392 232392 Fax: (+44) 2392 251369

Mounting Configuration:

In order for Xinger surface mount components to work optimally, the proper impedance transmission lines must be used to connect to the RF ports. If this condition is not satisfied, insertion loss, Isolation and VSWR may not meet published specifications.

All of the Xinger components are constructed from ceramic filled PTFE composites which possess excellent electrical and mechanical stability having X and Y thermal coefficient of expansion (CTE) of 17 ppm/°C.

An example of the PCB footprint used in the testing of these parts is shown below. An example of a DC-biased footprint is also shown below. In specific designs, the transmission line widths need to be adjusted to the unique dielectric coefficients and thicknesses as well as varying pick and place equipment tolerances

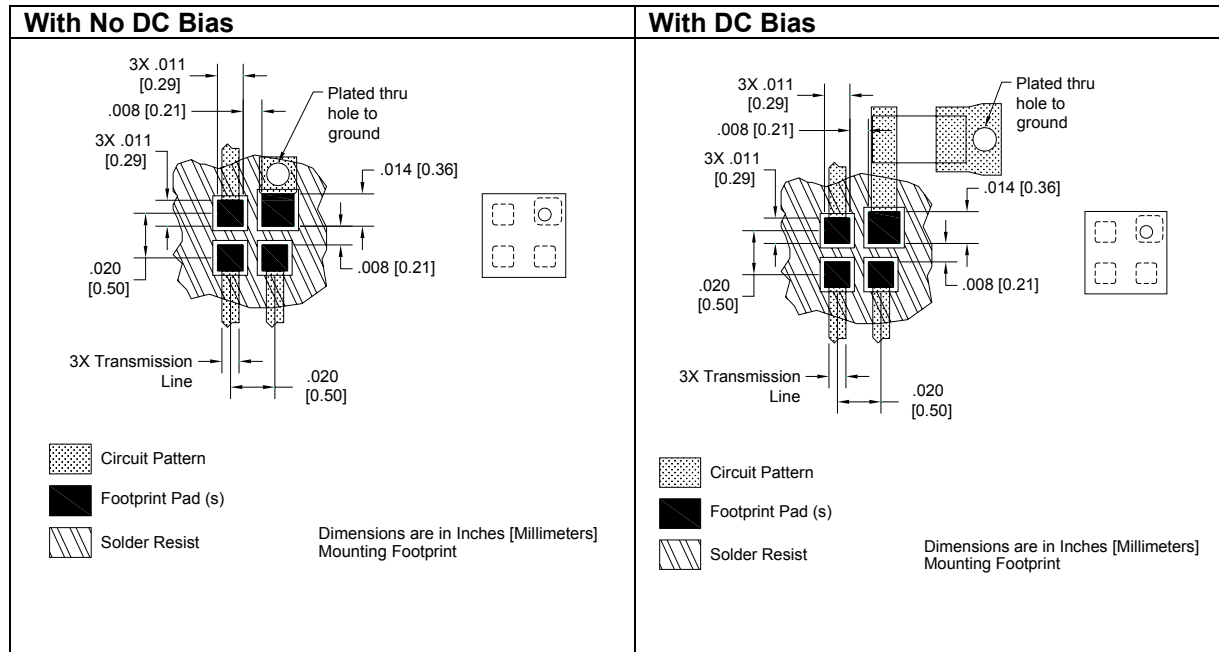

Packaging and Ordering Information

Parts are available in reel and are packaged per EIA 481-2. Parts are oriented in tape and reel as shown below. Minimum order quantities are 4000 per reel. See Model Numbers below for further ordering information.

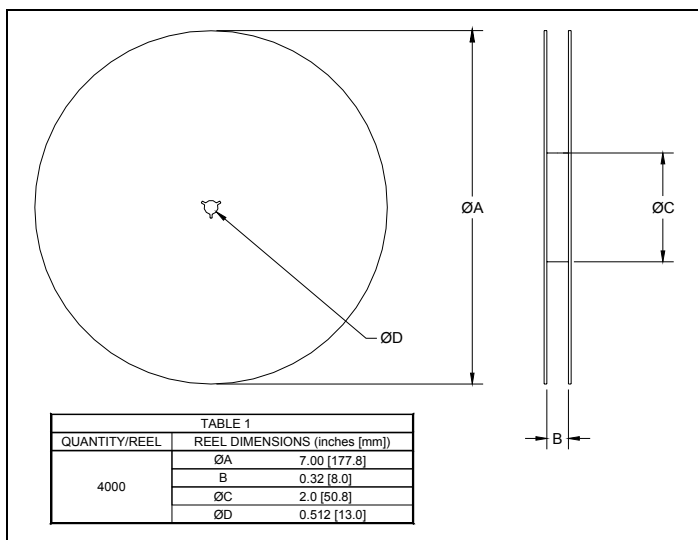
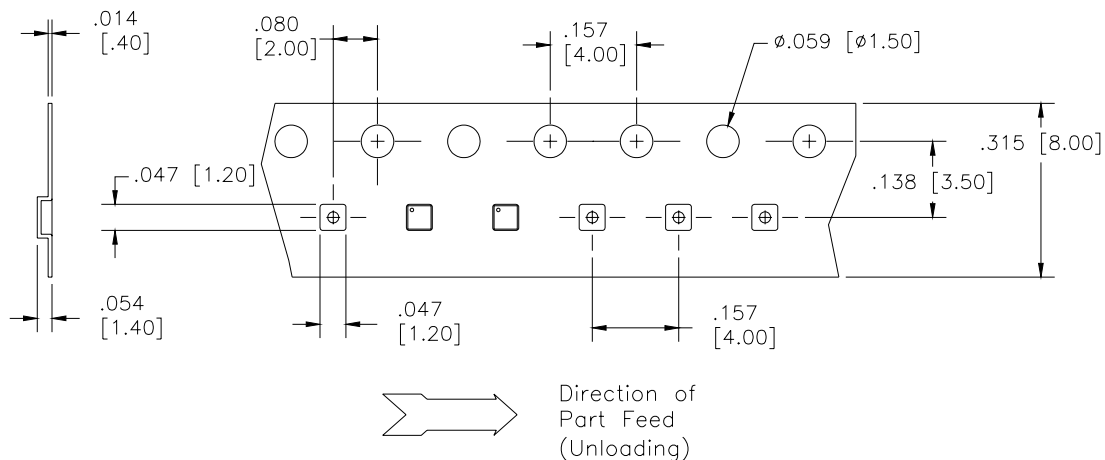

BD 2425 J 50 100 A 00

Function	Frequency	Package Dimensions	Unbalanced Impedance	Balanced Impedance + Coupling	Plating Finish	Codes
B = Balun	0110 = 100 – 1000 MHz	A = 150 x 150 mils (4mm x 4mm)	50 = 50 Ohm 75 = 75 Ohm	25 = 25 Ω Balanced 30 = 30 Ω Balanced 50 = 50 Ω Balanced 75 = 75 Ω Balanced	A = Gold P = Tin-Lead	
BD = Balun + DC	0810 = 800 – 1000 MHz	C = 120 x 120 mils (3mm x 3mm)		100 = 100 Ω Balanced 150 = 150 Ω Balanced 200 = 200 Ω Balanced 300 = 300 Ω Balanced 400 = 400 Ω Balanced		
F = Filter	0922 = 950 – 2150 MHz	E = 100 x 80 mils (2.5mm x 2mm)		03 = 3dB Hybrid		
FB = Filter / Balun	0826 = 800 – 6200 MHz	J = 80 x 50 mils (2mm x 1.25mm)		10 = 10dB Directional 20 = 20dB Directional		
C = 3dB Coupler	1222 = 1200 – 2200 MHz	L = 60 x 30 mils (1.5mm x 0.75mm)				
DC = Directional	1416 = 1400 – 1600 MHz	N = 40 x 40 mils (1mm x 1mm)				
J = RF Jumper	1722 = 1700 – 2200 MHz					
X = RF cross over	2326 = 2300 – 2600 MHz					
	2425 = 2400 – 2500 MHz					
	3150 = 3100 – 5000 MHz					
	3436 = 3400 – 3600 MHz					
	4859 = 4800 – 5900MHz					
	5153 = 5100 – 5300 MHz					
	5159 = 5100 – 5900 MHz					
	5759 = 5700 – 5900 MHz					