

Xinger®

Ultra Low Profile 0805 Balun 50Ω to 100Ω Balanced

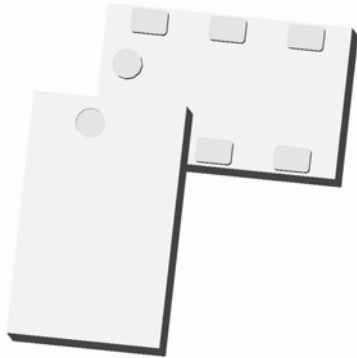

Description

The BD1631J50100A00 is a low profile sub-miniature balanced to unbalanced transformer designed for differential inputs and output locations on next generation wireless chipsets in an easy to use surface mount package covering 802.11b+g+n, GSM, DCS, PCS and UMTS. The BD1631J50100A00 is ideal for high volume manufacturing and is higher performance than traditional ceramic and lumped element baluns. The BD1631J50100A00 has an unbalanced port impedance of 50Ω and a 100Ω balanced port impedance*. This transformation enables single ended signals to be applied to differential ports on modern semiconductors. The output ports have equal amplitude (-3dB) with 180 degree phase differential. The BD1631J50100A00 is available on tape and reel for pick and place high volume manufacturing.

Detailed Electrical Specifications*: Specifications subject to change without notice.

Features:	Parameter	ROOM (25°C)						Unit
		Min.	Typ.	Max	Min.	Typ.	Max	
• 1.6 – 3.1 GHz	Frequency	2.0		2.5	1.6		3.1	GHz
• 0.7mm Height Profile	Unbalanced Port Imp.		50			50		Ω
• 50 Ohm to 2 x 50 Ohm	Balanced Port Imp. **		100			100		Ω
• 802.11 b & g +n Compliant	Return Loss	12	17.5		10	13		dB
• Low Insertion Loss	Insertion Loss***		0.6	0.75		0.75	1.0	dB
• DCS, PCS & UMTS Compliant	Amplitude Balance		0.35	0.65		0.7	1.0	dB
• Input to Output DC Isolation	Phase Balance		±2	±5		±2	±5	Degrees
• Surface Mountable	Power Handling			0.5			0.5	Watts
• Tape & Reel	Thermal Resistance			TBD			TBD	°C/Watt
• Non-conductive Surface	Operating Temperature	-55		+85	-55		+85	°C
• RoHS Compliant								

* Insertion Loss stated at room temperature (Insertion Loss is approximately 0.1 dB higher at +85 °C)

Outline Drawing

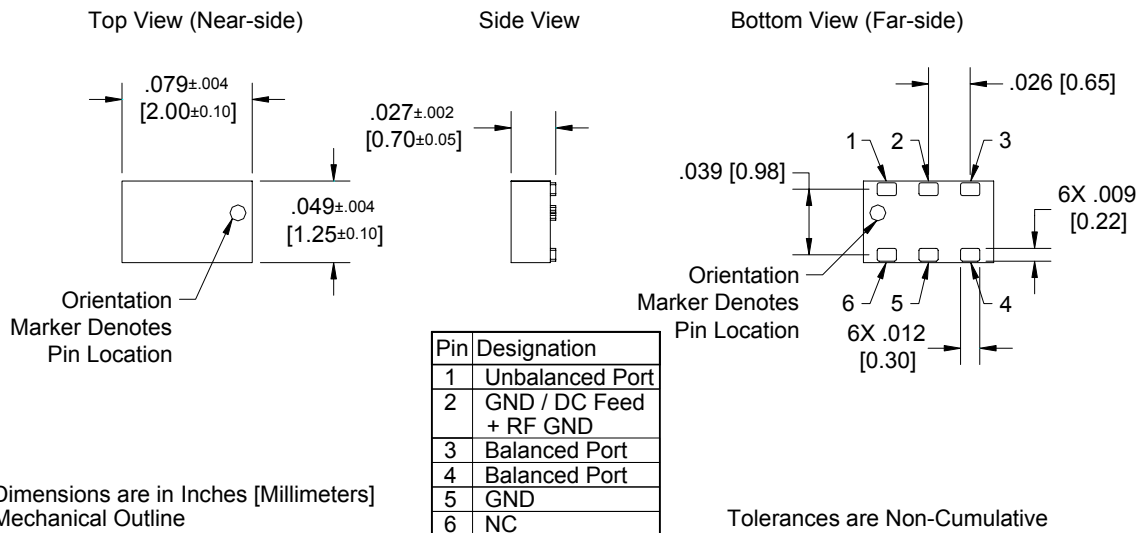

Typical Broadband Performance: 0 GHz. to 6.0 GHz.

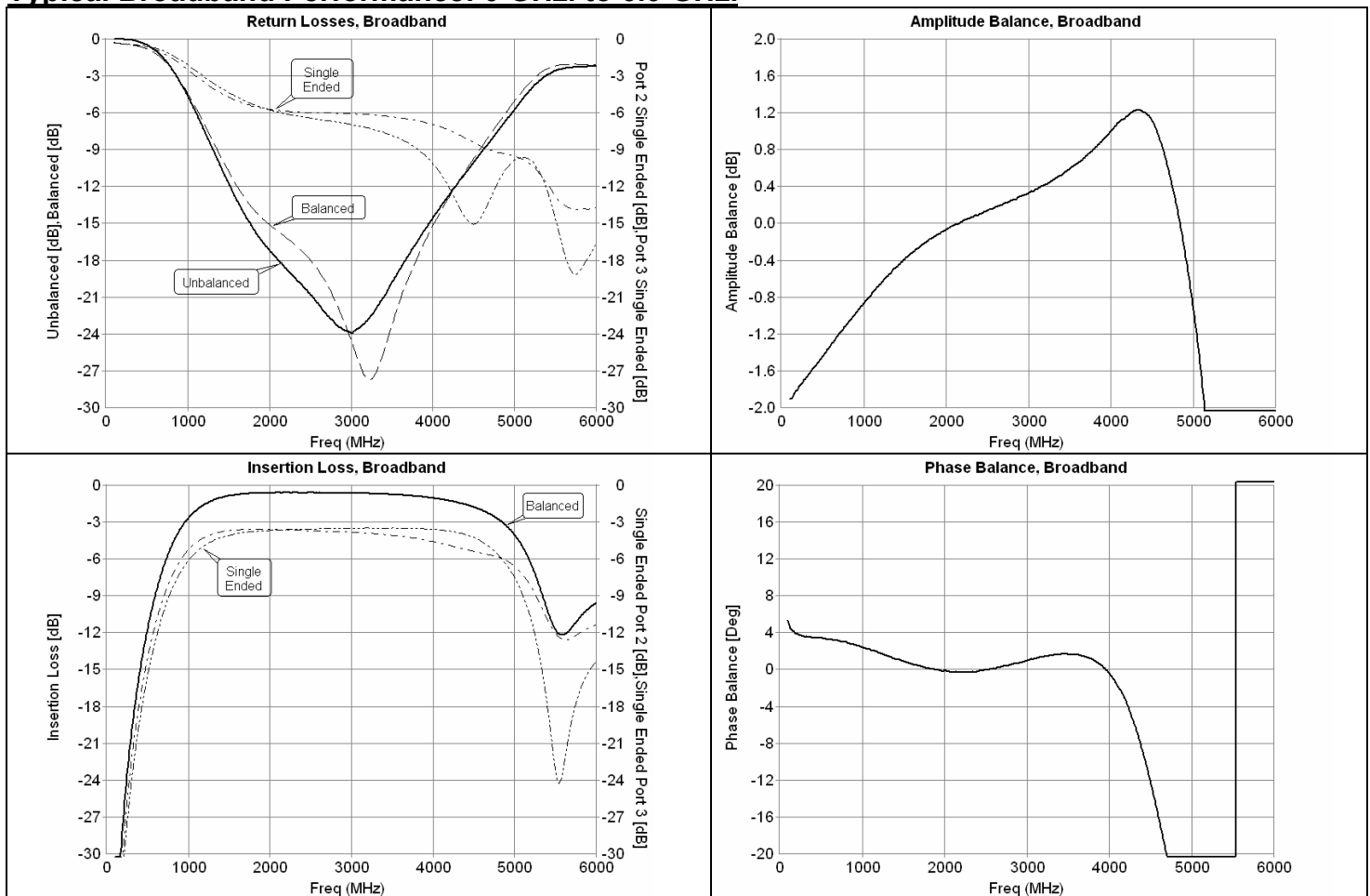

USA/Canada: (315) 432-8909
 Toll Free: (800) 411-6596
 Europe: +44 2392-232392

Available on Tape and Reel for Pick and Place Manufacturing.



Anaren

What'll we think of next?™

Typical Performance: 2.4 GHz. to 2.5 GHz.

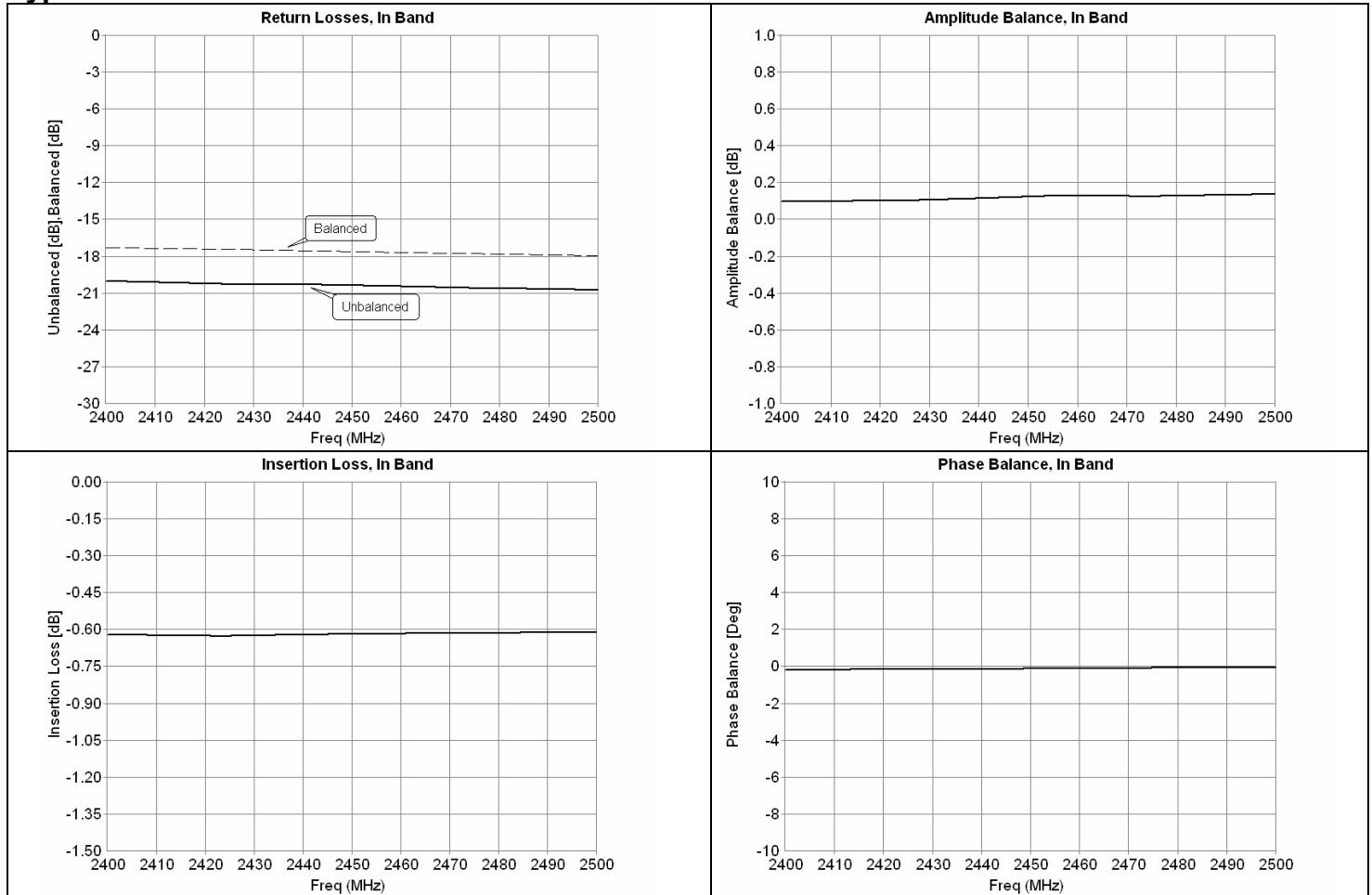

Mounting Configuration:

In order for Xinger surface mount components to work optimally, the proper impedance transmission lines must be used to connect to the RF ports. If this condition is not satisfied, insertion loss, Isolation and VSWR may not meet published specifications.

All of the Xinger components are constructed from ceramic filled PTFE composites which possess excellent electrical and mechanical stability having X and Y thermal coefficient of expansion (CTE) of 17 ppm/°C.

An example of the PCB footprint used in the testing of these parts is shown below. An example of a DC-biased footprint is also shown below. In specific designs, the transmission line widths need to be adjusted to the unique dielectric coefficients and thicknesses as well as varying pick and place equipment tolerances.

No Bias Footprint

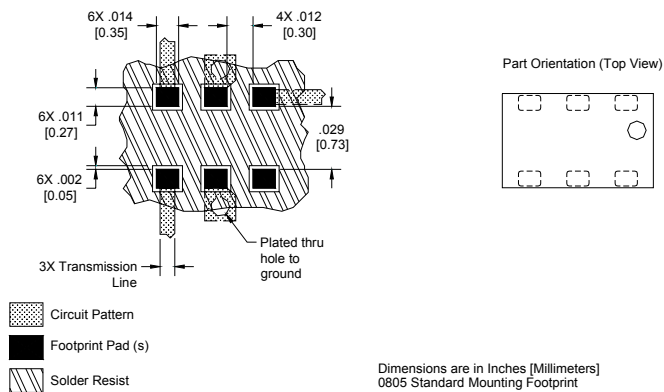

DC Bias Footprint

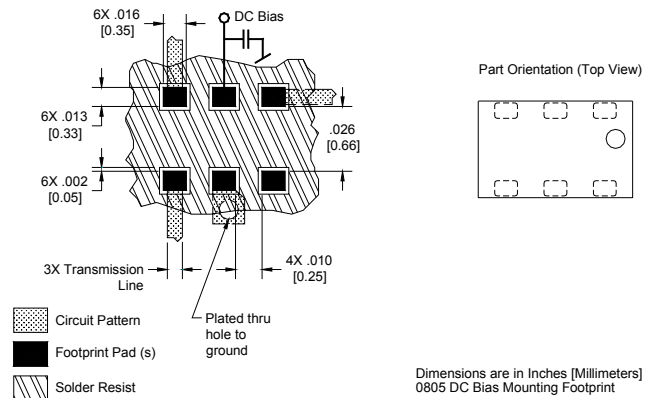

Packaging and Ordering Information

Parts are available in reel and are packaged per EIA 481-2. Parts are oriented in tape and reel as shown below. Minimum order quantities are 4000 per reel. See Model Numbers below for further ordering information.

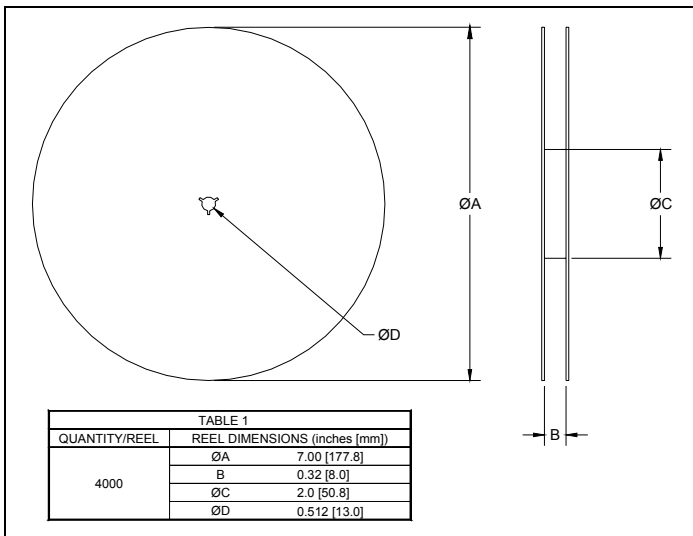
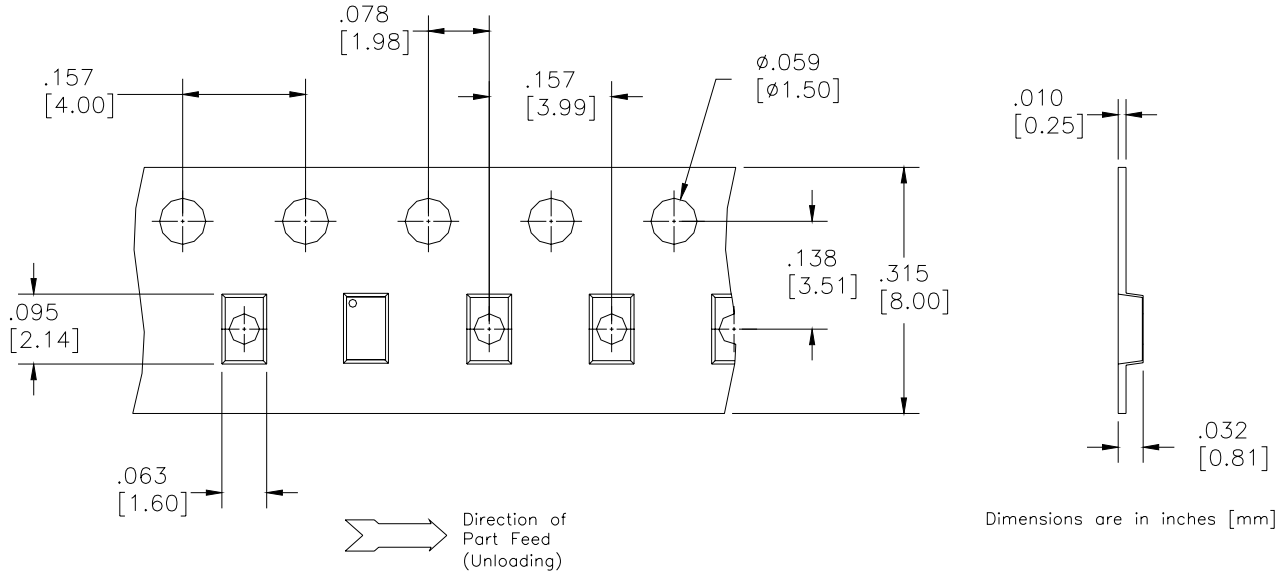

BD 2425 J 50 100 A 00

Function	Frequency	Package Dimensions	Unbalanced Impedance	Balanced Impedance + Coupling	Plating Finish	Codes
B = Balun BD = Balun + DC F = Filter FB = Filter / Balun C = 3dB Coupler DC = Directional J = RF Jumper X = RF cross over	0110 = 100 – 1000 MHz	A = 150 x 150 mils (4mm x 4mm)	50 = 50 Ohm	25 = 25 Ω Balanced	A = Gold P = Tin-Lead	
	0810 = 800 – 1000 MHz	C = 120 x 120 mils (4mm x 4mm)	75 = 75 Ohm	30 = 30 Ω Balanced		
	0922 = 950 – 2150 MHz	D = 126 x 79 mils (3.2mm x 2mm)		50 = 50 Ω Balanced		
	0826 = 800 – 6200 MHz	E = 100 x 80 mils (3mm x 2mm)		75 = 75 Ω Balanced		
	1222 = 1200 – 2200 MHz	G = 120 x 60 mils (3mm x 1.5mm)		100 = 100 Ω Balanced		
	1416 = 1400 – 1600 MHz	J = 80 x 50 mils (2mm x 1.25mm)		150 = 150 Ω Balanced		
	1722 = 1700 – 2200 MHz	K = 90 x 60 mils (2.25mm x 1.5mm)		200 = 200 Ω Balanced		
	2326 = 2300 – 2600 MHz	L = 60 x 30 mils (1.5mm x 0.75mm)		300 = 300 Ω Balanced		
	2425 = 2400 – 2500 MHz	N = 140 x 80 mils (3.5mm x 2mm)		400 = 400 Ω Balanced		
	3150 = 3100 – 5000 MHz			03 = 3dB Hybrid		
	3436 = 3400 – 3600 MHz			10 = 10dB Directional		
	4859 = 4800 – 5900MHz			20 = 20dB Directional		
	5153 = 5100 – 5300 MHz					
5159 = 5100 – 5900 MHz						
5759 = 5700 – 5900 MHz						

USA/Canada: (315) 432-8909
 Toll Free: (800) 411-6596
 Europe: +44 2392-232392

Available on Tape and Reel for Pick and Place Manufacturing.



Anaren

What'll we think of next?™