

Aluminum Nitride Terminations

125 Watts, 50 Ω

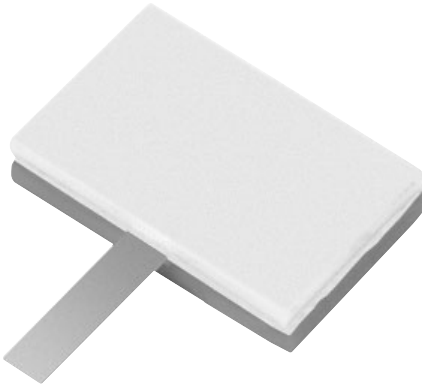

Features

- DC – 5.0 GHz
- 125 Watts
- Aluminum Nitride (AlN) Ceramic
- Welded Silver Leads
- Non-Nichrome Resistive Element
- Low VSWR
- 100% Tested

General Specifications

Resistive Element:	Thick film
Substrate:	Aluminum nitride ceramic
Cover:	Alumina ceramic
Mounting Flange:	Copper, nickel plated per QQ-N-290
Lead(s):	99.99% pure silver (.005" thk)

Electrical Specifications

Resistance Value:	50 ohms, ±5%
Frequency Range:	DC - 5.0 GHz
Power:	125 Watts
V.S.W.R.:	1.25:1

Notes: Tolerance is ±.010, unless otherwise specified. Operating temperature is -55°C to +150°C (see chart). Designed to meet or exceed applicable portions of MIL-E-5400. All dimensions are in inches. Lead length 0.15" minimum.

Specifications subject to change without notice.

Outline Drawing

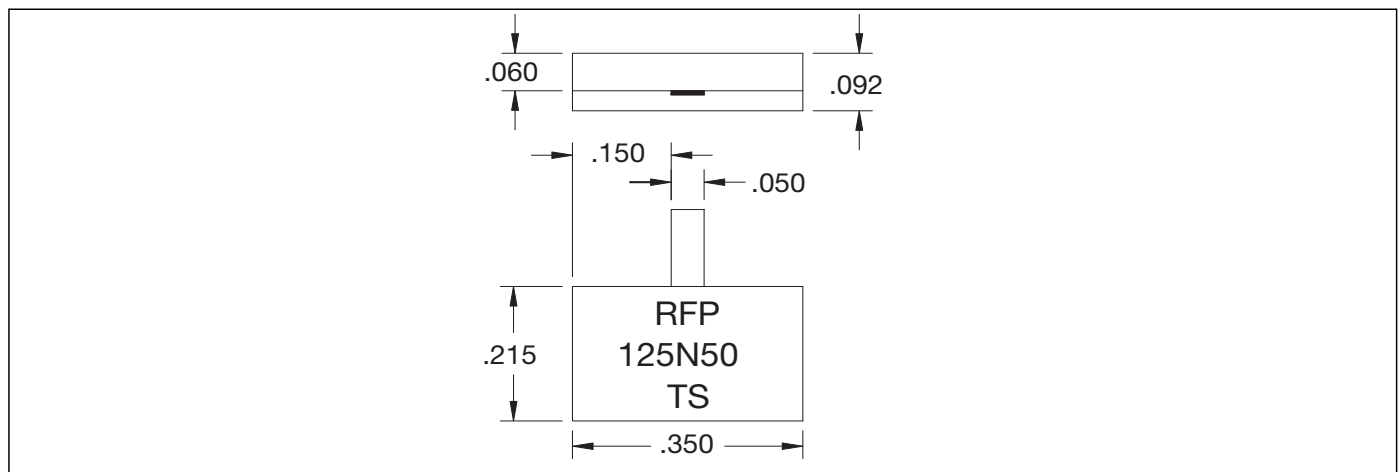

VER. 12/5/01

Model RFP-125N50TS

Anaren

RF Power

Typical Performance

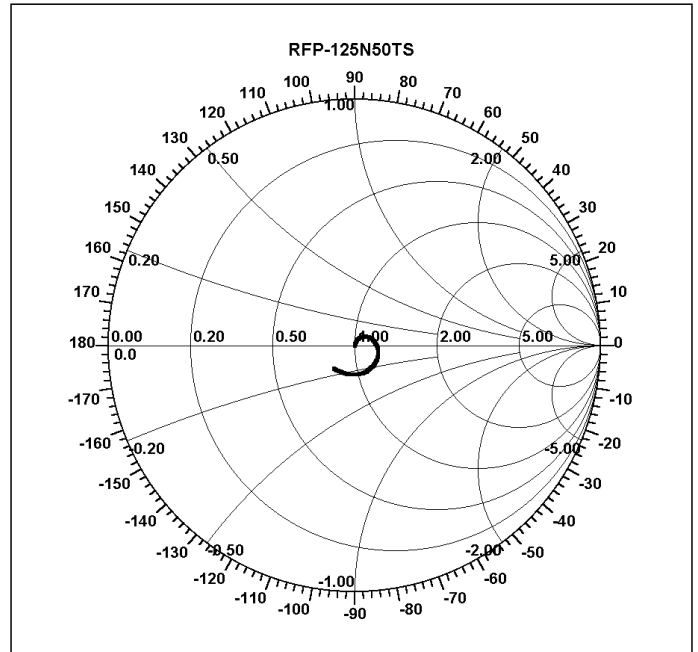
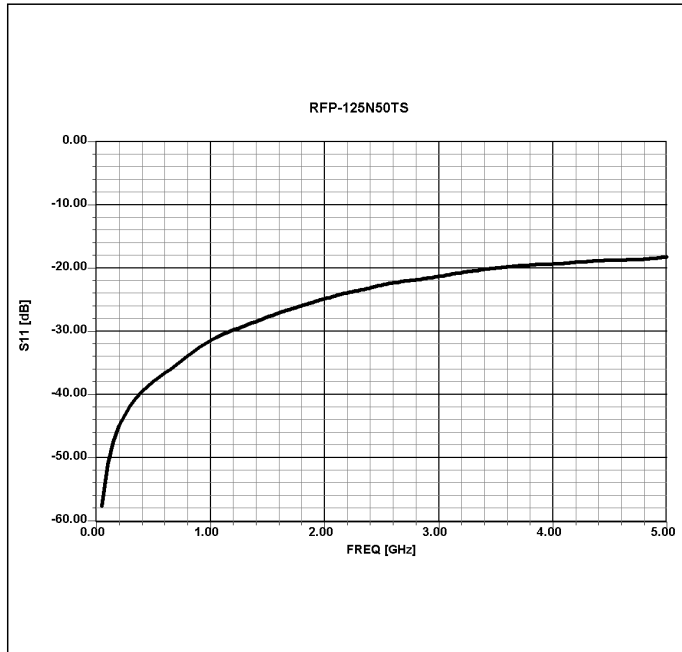

Power Derating

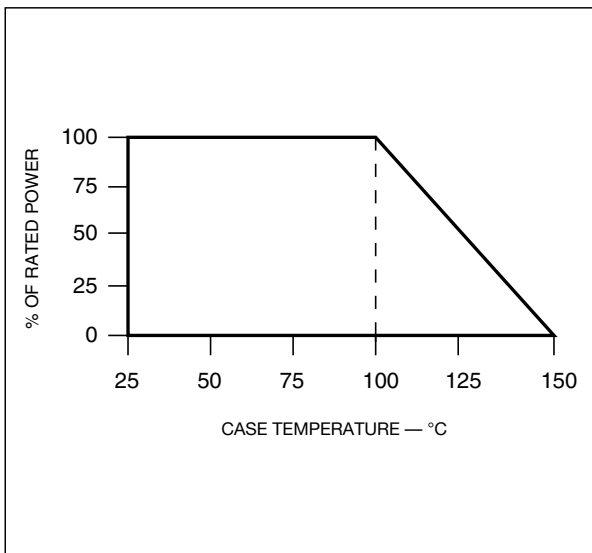

Suggested Mounting Procedures

SUGGESTED STRESS RELIEF METHODS

- BOARD LOWER THAN LEAD.
- BOARD EVEN WITH LEAD.

NOT RECOMMENDED APPLICATION

- BOARD LOWER THAN LEAD.
- BOARD HIGHER THAN LEAD.

SCALE: ~~~~~

1. Make sure that the devices are mounted on flat surfaces (.001" under the device) to optimize the heat transfer.
2. Position device on mounting surface and solder in place using an SN96 type solder.
3. Solder leads in place using an SN63 type solder with a controlled temperature iron (700°F).