

General Specifications

Resistive Element:	Thick film
Substrate:	Beryllium oxide ceramic
Cover:	Alumina ceramic
Mounting Flange:	Copper, nickel plated per QQ-N-290
Lead(s):	99.99% pure silver (.005" thk)

Features

- DC - 2.0 GHz
- 150 Watts
- BeO Ceramic
- Welded Silver Leads
- Non-Nichrome Resistive Element
- 100% Tested

Electrical Specifications

Resistance Value:	100 ohms, ±5%
Frequency Range:	DC - 2.0 GHz
Power:	150 Watts
Capacitance:	3.2 pF

Notes: Tolerance is ±.010, unless otherwise specified. Operating temperature is -55°C to +150°C (see chart). Designed to meet or exceed applicable portions of MIL-E-5400. All dimensions are in inches. Lead length 0.15" minimum.

Specifications subject to change without notice.

Outline Drawing

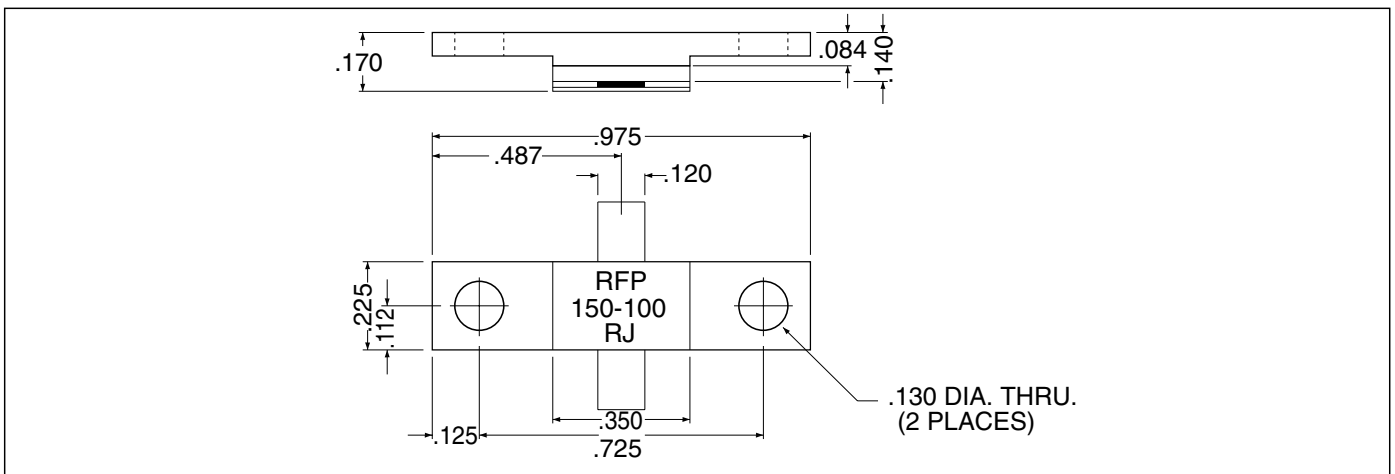

VER. 12/5/01

Model RFP-150-100RJ



RF Power

Typical Performance

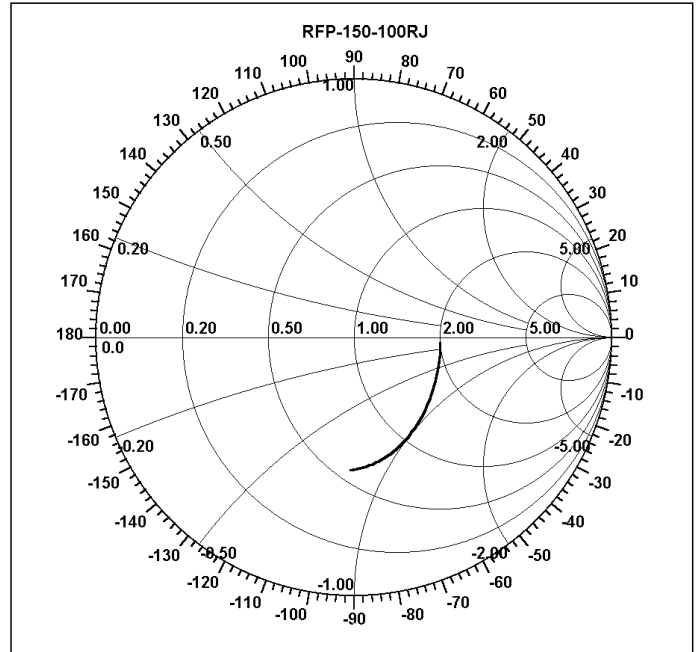
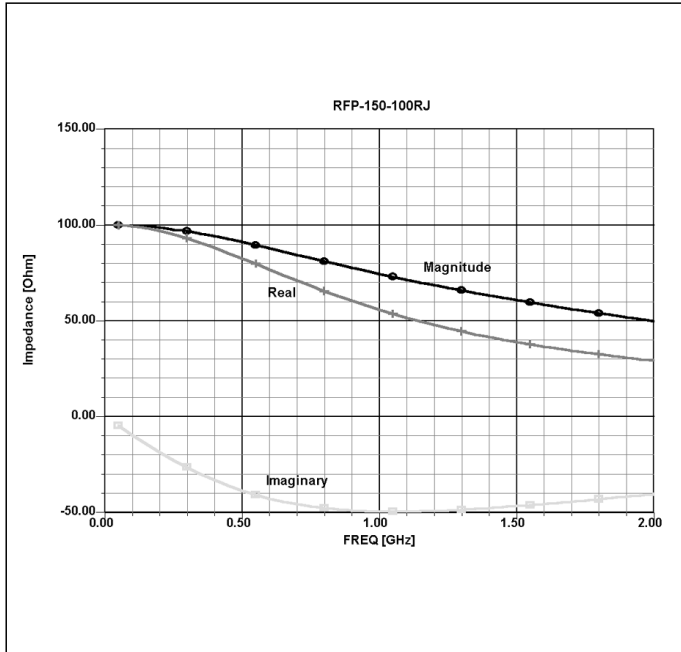

Power Derating

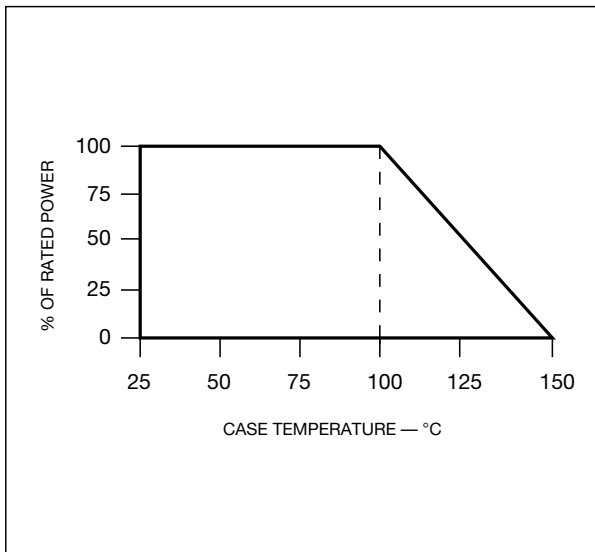

Suggested Mounting Procedures

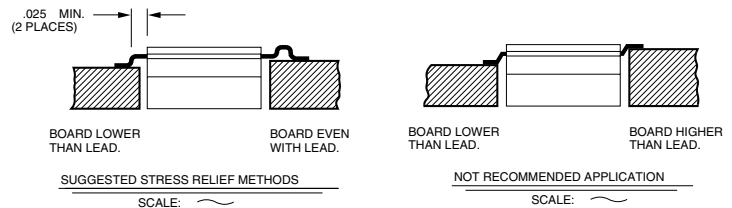

1. Make sure that the devices are mounted on flat surfaces (.001" under the device) to optimize the heat transfer.
2. Drill & tap the heatsink for the appropriate thread size to be used.
3. Coat heatsink with a minimum amount of high quality silicone grease (.001" max. thickness).
4. Position device on mounting surface and secure using socket head screws, flat & split washers. Torque screws to the appropriate value. Make sure that the device is flat against the heatsink. (Care should be taken to avoid upward pressure of the leads towards the lid).
5. Solder leads in place using an SN63 type solder with a controlled temperature iron (210°C).