

RF Power introduced its first product in 1987 and has since designed, manufactured and supported the most reliable line of high-power resistive components in the industry. Employing state-of-the-art equipment, manufacturing and quality assurance practices, our line of resistors, terminations and attenuators continue to be among the most cost effective, innovative and reputable solutions in the industry. In addition, RF Power's commitment to customer service excellence has resulted in our receiving several quality awards from major customers.

Traditionally, high-power resistive components have been constructed using a Beryllium Oxide (BeO) ceramic substrate. In recent years several governments and agencies have enacted prohibitions against the use of Beryllium Oxide. In response to these industry developments, RF Power undertook a research and development mission to develop an effective alternative to BeO, using an Aluminum Nitride (AlN) ceramic in its place. AlN has thermal and electrical properties comparable to BeO, but none of the environmental issues associated with it. The most recent addition to our product offering is a new line of RF Power Alumina (Al<sub>2</sub>O<sub>3</sub>) terminations. Alumina has electrical properties comparable to both BeO and AlN, but with a reduced power handling capability. This line is intended as a low-cost alternative to both BeO and AlN for less demanding applications.

RF Power high-power resistive products are widely used in the wireless industry, as well as in medical, industrial, military and aerospace applications. Our resistive products cover a wide range of communications bands, such as NMT-450, NMT-900, AMPS, ETACS, IS-95, GSM, DCS, PCS, W-CDMA, 3G, Wireless LAN, WCS, ISM and satellite communication bands. Typical applications for our products would be in splitter and combiner networks for power amplifiers, signal sensing in feed-forward amplifiers, isolator and circulator construction, delay line and cavity filter assemblies, and high power RF generators.

RF Power high-power resistive components are available in a wide variety of mechanical configurations including surface mount, chip, flanged, flangeless, coaxial and cable load.

# Introduction

# Anaren

## RF Power

### INSTALLATION DETAILS-

#### Surface Mount-

When mounting surface mount resistors, it is important to ensure that the best possible thermal path exists between the resistor and the heat sink. This should be done using solder filled vias to connect the ground pad on the resistor with the heat sink. To further improve the thermal connection, two screws should be mounted on either side of the resistor, pressing the PCB board tightly against the heat sink.

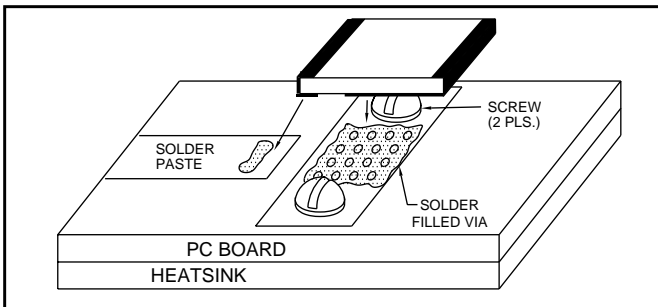

It is important to keep in mind that the power handling specified for the given resistor assumes that the recommended mounting procedure is followed.

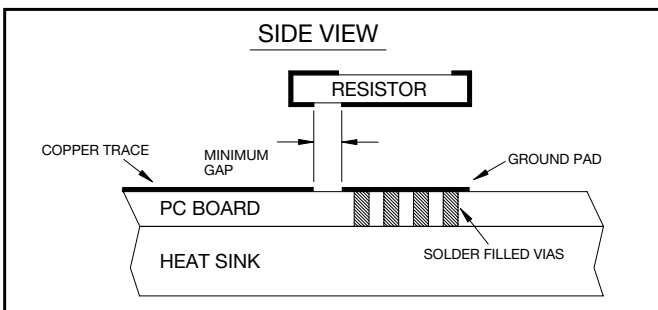

**Footprint:** When making a footprint for a surface mount resistor, it is important to leave a gap between the input trace and the ground pad that is no less than the gap present on the resistor. All other footprint dimensions can be sized as desired.

It is recommended to make traces 10-20 mils larger than the solder terminals on the resistors (to allow for a solder fillet).

#### Chip and Flangless-

Chip and flangeless resistors should be mounted directly on a flat heat sink surface (0.001" under the device) to achieve the best possible thermal connection to the heat sink. Mount the resistor using a solder with a melting point higher than the one used when attaching the lead.

When mounting the lead, make sure that a stress relief is present either in the form of a small loop or a large S-style bend.

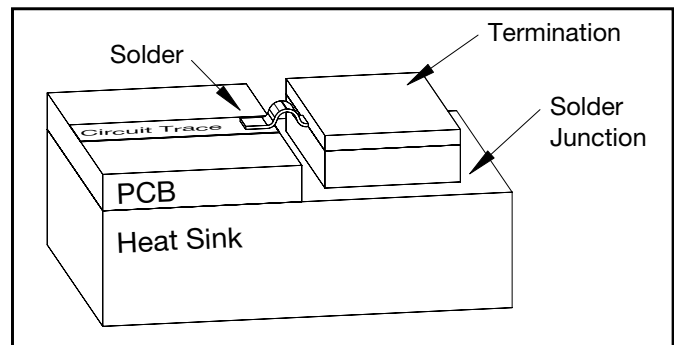

If no stress relief is present repeated thermal cycling will cause metal fatigue in the lead and cause it to break or detach.

#### Epoxy-

Conductive epoxies such as silver epoxy can also be used to mount the resistor, but be aware that the silver epoxy has a much lower thermal conductivity than solder. The thickness of the silver epoxy used to mount the resistor should be kept to a minimum to avoid introducing a thermally insulating layer between the resistor and heat sink. Be aware that if the resistor is used in a sealed package, outgassing from the epoxy may contaminate other parts.

## RF Power

### Flanged-

Flange mounted resistors should be bolted down on a flat surface (0.001" under the device) on the heat sink. The heat sink should be drilled and tapped for the appropriate screw and thread size. To further improve the heat transfer, apply a thin layer (max. 0.001") of high quality thermal grease under the device. Mount the resistor with flat and split washers, and torque screws to appropriate value.

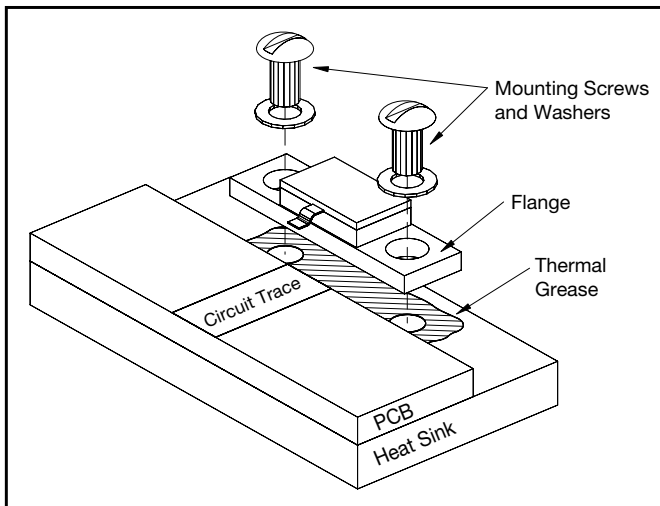

When mounting the lead, make sure that a stress relief is present either in the form of a small loop or a large S-style bend. If no stress relief is present repeated thermal cycling will cause metal fatigue in the lead and make it break or detach.



## **RF Power**

### *Chip Terminations*

Part Number	Power (Watts)	Frequency	VSWR Max:1	Page
RFP-060120A25X50	10	DC-6.0 GHz	1.25	4.8.3
RFP-100200A25X50	20	DC-6.0 GHz	1.25	4.8.3
RFP-250250A4X50	30	DC-3.0 GHz	1.25	4.8.3
RFP-250375A4X50	40	DC-3.0 GHz	1.25	4.8.3
RFP-375250A4X50	40	DC-2.5 GHz	1.20	4.8.3
RFP-375375A4X50	40	DC-2.5 GHz	1.20	4.8.3

### *Surface Mount Terminations*

Part Number	Power (Watts)	Frequency	VSWR Max:1	Page
RFP-060120A15Z50	8	DC-4.0 GHz	1.25	4.8.5
RFP-100200A25Z50	10	DC-3.0 GHz	1.25	4.8.5
RFP-250250A4Z50	12	DC-3.0 GHz	1.25	4.8.5
RFP-250375A4Z50	15	DC-3.0 GHz	1.25	4.8.5
RFP-375250A4Z50	15	DC-2.5 GHz	1.25	4.8.5
RFP-375375A4Z50	18	DC-2.5 GHz	1.25	4.8.5

### *Flangeless Terminations*

Part Number	Power (Watts)	Frequency	VSWR Max:1	Page
RFP-20A50T	20	DC-6.0 GHz	1.25	4.8.7
RFP-30A50TPP	30	DC-3.0 GHz	1.25	4.8.7
RFP-40A50TEN	40	DC-3.0 GHz	1.25	4.8.7
RFP-40A50TB	40	DC-2.5 GHz	1.20	4.8.7
RFP-40A50TD	40	DC-2.5 GHz	1.20	4.8.7

### *Flanged Terminations*

Part Number	Power (Watts)	Frequency	VSWR Max:1	Page
RFP-20A50TV	20	DC-6.0 GHz	1.25	4.8.9
RFP-20A50TVR	20	DC-6.0 GHz	1.25	4.8.9
RFP-30A50TP	30	DC-3.0 GHz	1.25	4.8.9
RFP-30A50TPR	30	DC-3.0 GHz	1.25	4.8.9
RFP-30A50TPC	30	DC-3.0 GHz	1.25	4.8.9
RFP-40A50TE	40	DC-3.0 GHz	1.25	4.8.9
RFP-40A50TBF	40	DC-2.5 GHz	1.20	4.8.9
RFP-40A50TC	40	DC-2.5 GHz	1.20	4.8.9

