

# Xinger®

## SMT Crossover

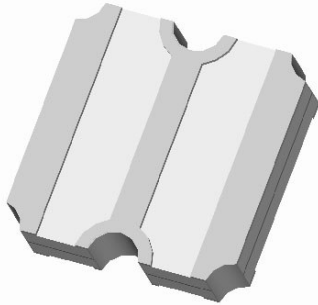

### Description

The X2A is a low profile crossover to intersect an RF and DC circuit trace in an easy to use surface mount package designed for frequencies up to 6 GHz. The X2A is ideal for any application where an RF circuit must intersect with a DC circuit without resorting to a multilayer PCB. Parts have been subjected to rigorous qualification testing and units are 100% tested. They are manufactured using materials with x and y thermal expansion coefficients compatible with common substrates such as FR4, G-10 and polyamide.

### Features:

- DC – 6.0 GHz
- RF – DC Crossover
- Low Loss
- DC Isolation
- Surface Mountable
- Tape And Reel
- Convenient Package
- 100 % Tested

### ELECTRICAL SPECIFICATIONS\*\*

Frequency	Port Impedance	Return Loss		
GHz	Ohms	dB Min		
DC – 2.5	50	20		
2.5 – 4.0	50	20		
4.0 – 6.0	50	15		
Insertion Loss	Power	⊙JC	Operating Temp.	
dB Max	Watts	°C / Watt	°C	
0.05	30	250.9	-55 to +85	
0.10	15	250.9	-55 to +85	
0.15	10	250.9	-55 to +85	

\*\*Specification based on performance of unit properly installed on microstrip printed circuit boards with 50 Ω nominal impedance. Specifications subject to change without notice.

### Outline Drawing

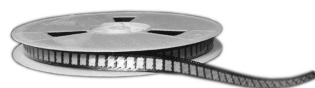
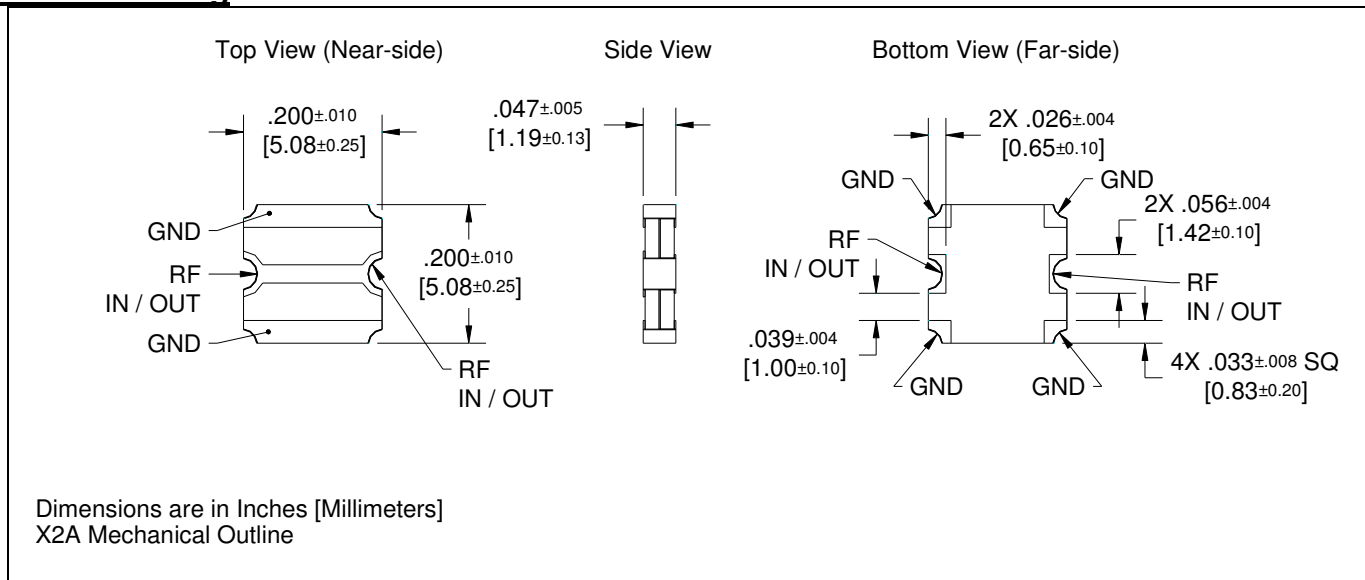

### Typical Performance: 0.5 GHz. to 6.0 GHz.

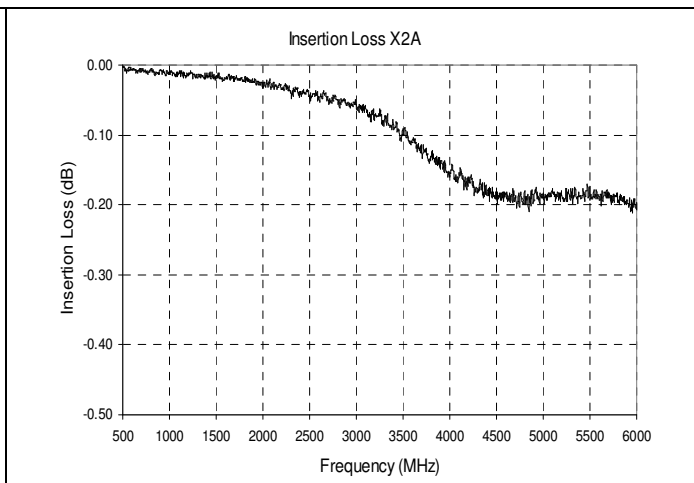
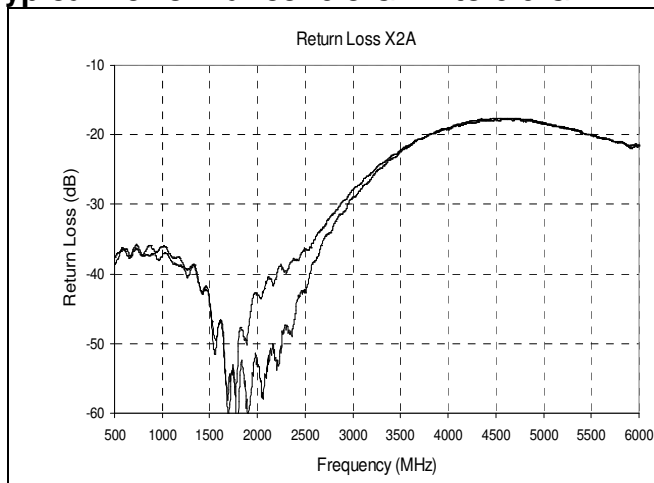

### Mounting

In order for Xinger crossovers to work optimally, there must be 50Ω transmission lines leading to and from all of the RF ports. Also, there must be a very good ground to the corners of the crossover to insure proper electrical performance. If either of these two conditions are not satisfied, insertion loss, VSWR and isolation parameters may not meet published specifications.

When a surface mount crossover is mounted to a printed circuit board, the primary concerns are; insuring the RF pads of the device are in contact with the circuit trace of the PCB and insuring the ground plane of neither the component nor the PCB is in contact with the RF signal. Since the component is not symmetrical, the crossovers are specifically oriented in the tape and reel. An example of how the PCB footprint could look is shown below. In specific designs, the 50Ω lines need to be adjusted to the unique dielectric coefficients and thicknesses as well as varying pick and place equipment tolerances.

### Mounting Footprint

To ensure proper electrical and thermal performance there must be a ground plane with 100% solder connection underneath the part

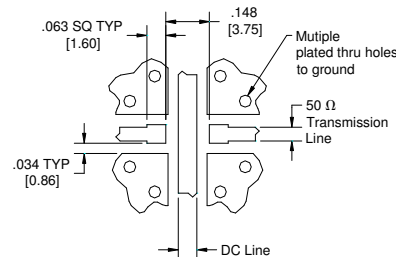
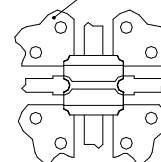

Dimensions are in Inches [Millimeters]  
X2A Rev A Mounting Footprint

