

cover story

# Baluns Shrink To Tiny 0404 Footprint

These miniature baluns make the transition from balanced to unbalanced devices in a fraction of the real estate required by previously available surface-mount components.

C

onsumer and commercial electronic designs call for the smallest possible components to save space and power. Balanced-unbalanced transformers or baluns have traditionally been based on transmission lines, such as coaxial wires, stripline, or microstrip, and often somewhat large as a result. By applying their multilayer techniques, Anaren Microwave had already succeeded in developing baluns in 0805 ( $0.08 \times 0.05$  in.) and 0603 ( $0.06 \times 0.03$  in.) package sizes. And to meet the ever-increasing demands for decreasing size, the firm has announced a 0404-packaged family of surface-mount baluns measuring just  $0.04 \times 0.04 \times 0.026$  in., with no sacrifice in performance compared to their larger counterparts.

The low height profile of these new baluns makes them ideal for module designs such as system-in-package (SIP) solutions. In addition to low height, the baluns offer fine pin pitch, excellent electrical performance, and low price. The 0404 baluns feature a land-grid-array (LGA) interface to occupy only  $0.0016$  in.<sup>2</sup> when mounted on a printed-wire-board (PWB) substrate. In contrast to existing offerings, this SMT interface requires no additional PWB space for the solder land pads. In spite of their compact size and simple four-pin construction, these baluns are also suitable for DC biasing. The baluns, which operate past 5 GHz, are suitable for 2.4-GHz Bluetooth and IEEE 802.11b/g

wireless local-area networks (WLANs), 3.5-GHz WiMAX, 5-GHz IEEE 802.11a WLANs and Home Cordless applications, and a wide range of consumer applications. Insertion loss is typically 0.6 dB at 2.4 GHz with better than 23 dB return loss at that frequency.

The firm's advanced passive-com-

1. A standard 0805 packaged device has this standard fanout pin configuration for external connections.

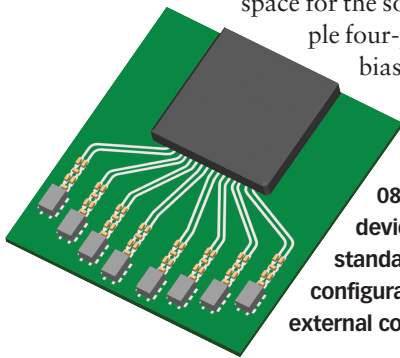

## NIELS KIRKEBY

### R & D Manager

Anaren, Inc., 6635 Kirkville Rd., East Syracuse, NY 13057; (800) 411-6596, (315) 432-8909, FAX: (315) 432-0189, Internet: [www.anaren.com](http://www.anaren.com).

Table 1: Products available for sampling

MODEL NUMBER	FREQUENCY (GHz)	UNBALANCED PORT IMPEDANCE ( $\Omega$ )	BALANCED PORT IMPEDANCE ( $\Omega$ )	INSERTION LOSS (dB, MAX)	AMPLITUDE BALANCE (dB, MAX)	PHASE BALANCE (DEG., MAX)	RETURN LOSS (dB, MIN)
BD2425N5075A00	2.4 to 2.5	50	75	0.9	0.9	3	14
BD2425N50100A00	2.4 to 2.5	50	100	0.7	0.6	3	18
BD4859N50100A00	4.8 to 5.9	50	100	0.7	1.5	9	12.7
BD2450P50100A00	2.4 to 2.5	50	100	0.7	0.6	3	18
	4.8 to 5.9	50	100	0.7	1.5	9	12.7

## Avionics Transistors for Commercial and Military Applications

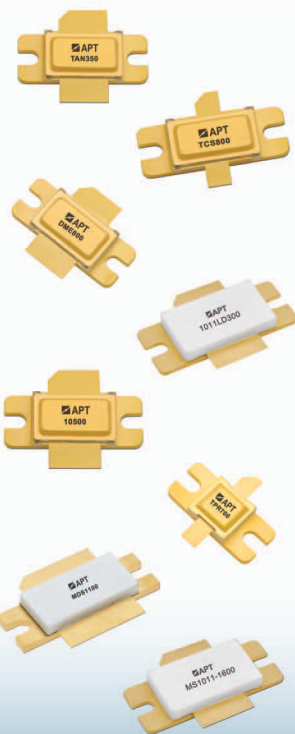

- TAN350**  
 350 Watt, Class C, designed for Broadband TACAN systems covering 1030-1090 MHz
- TCS800**  
 800 Watt, Class C, designed for TCAS systems covering 1030-1090 MHz
- DME800**  
 800 Watt, Class C, designed for Broadband DME systems covering 1025-1150 MHz
- 1011LD300**  
 300 Watt, Class AB, designed for Transponder/Interrogator systems, 1030-1090 MHz
- 10500**  
 500 Watt, Class C, designed for Mode S, 32  $\mu$ S, 2% pulsing at  $V_{cc}=50V$ , 45% eff
- TPR700**  
 350 Watt, Class C, designed for Transponder systems, 1090 MHz
- MDS1100**  
 1100 Watt, Class C, designed for standard Mode S, 128  $\mu$ S pulsing at 1030 MHz
- MS1011**  
 1600 Watt, IFF Applications, 1030-1090 MHz Samples 4Q05



www.advancedpower.com  
tel: 408-986-8031

ponent technology allows for the integration of multiple 0404 balun building blocks into an integrated package. This integrated package can contain a mix of multiple frequencies (i.e., 2.4 and 5.0 GHz) and different balanced/unbalanced impedance combinations. Dual baluns (0804), triple baluns (1204), and quad baluns (1604) can be realized using this packaging concept.

Figure 1 represents a generic implementation demonstrating the standard “fan-out” configuration using standard 0805 balun and discrete devices connected to the input/output (I/O) pins of a typical transceiver chip. Significant PWB space is required in this realization.

Figure 2 clearly demonstrates the significant advantages of implementing a modular balun (dual-balun) approach to maximize on available space while not compromising performance or cost. This dual balun, measuring  $0.080 \times 0.040$  in., contains the same functionality as two larger discrete baluns. The use of the dual balun allows for the mounting in close proximity to a semiconductor device since

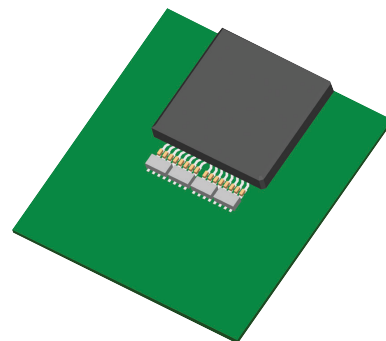

2. The modular approach to implementing multiple baluns in a package is shown with this dual-balun package configuration.

Support Products for Microwave & Fiber Optic Systems

ThermOptics®

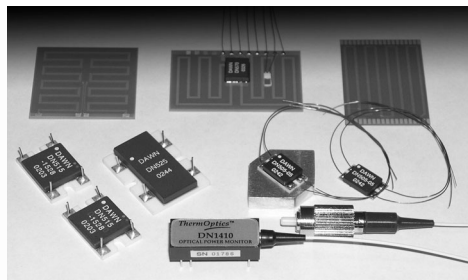

**Optical Power Monitor**

- Measure Optical Power from 100µW to 1mW
- Wavelength form 900nm to 1600nm
- 0.500 Volts Output Increase per Decade Increase in Optical Power
- Integrated Single Mode Fiber, InGaAs, Photodiode, and Temperature Compensated Log Amplifier
- Single +5VDC Operation

**Subminiature Proportional & PI Controlled Heaters**

- Beryllia and Aluminum Nitride Heater Substrate
- Self Contained Control Electronics
- Temperature set with a Single Resistor
- Set temperature form Ambient to 150°C
- 5 to 50VDC Operation
- 5 to 50Watts of Power

**Control the Temperature of:**

- Microwave Frequency Sources
- Saw Filters
- Optical Arrayed Waveguides (AWGs)

www.thermoptics.com

1004 Malory Way • Carson City, NV 89701  
PH: 775-882-7721 • FAX: 775-882-7675 • info@thermoptics.com

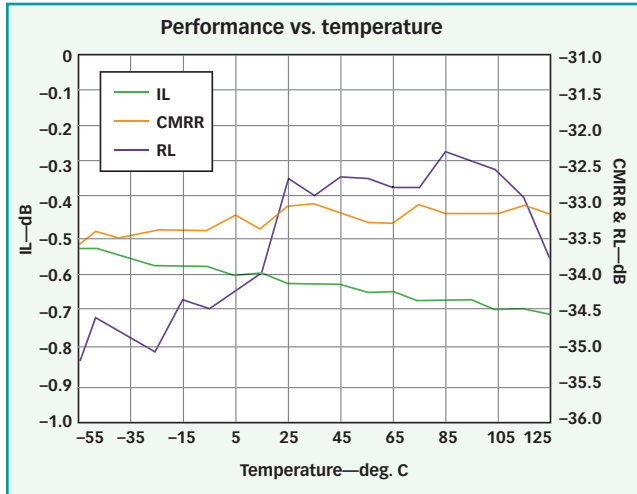

3. The electrical performance (insertion loss, return loss, and CMRR) of the BD2425N50100A00 0404 balun remains stable over a wide range of temperatures.

the pin pitch of the balun closely matches that of the IC. If additional matching is needed, 0201 discrete components can be used, complementing the component spacing allowed by the balun. Table 1 provides a list of current products available for sampling. All common impedances can be realized in these 0404 packages. The miniature 0404 baluns are very stable with temperature, with an insertion loss slope with temperature of about 1 mdB/°C for the BD2425N50100A00 part (Fig. 3).

When measuring the balun or simulating performance using two single-ended ports rather than a differential port, the equations given below can be used to calculate the differential performance. The single-ended input is assumed to be port 1 and the differential output pair is assumed to be ports 2 and 3.

Insertion loss (IL) can be found from:

$$IL = 10 \text{Log}(|S_{21}|^2 + |S_{31}|^2)$$

Balanced return loss can be found from:

$$SD_{22} = 20 \text{Log} \left| \frac{1}{2}(S_{22} + S_{33}) - \frac{1}{2}(S_{23} + S_{23}) \right|$$

The amplitude balance (AB) can be found from:

$$AB = 20 \text{Log} \left| \frac{S_{31}}{S_{21}} \right|$$

while the phase balance (PB) can be calculated from:

$$PB = \frac{180}{\pi} \arctan \left( \frac{\text{Im}ag \left( \frac{S_{31}}{S_{21}} \right)}{\text{Real} \left( \frac{S_{31}}{S_{21}} \right)} \right)$$

This phase balance is relative to the desired 180°.

- Products: Connector & Cable Assemblies for RF / MICROWAVE.
- Professional R&D can design and develop new products according to your specification.
- Machining parts are direct under over advanced multi-spindle combined CNC lathe machines from ø1mm up to ø51mm with different material of Beryllium copper, Phosphor Bronze, Brass, Aluminum, Stainless Steel.

Made in TAIWAN Top Quality



LOW LOSS / GOOD RETURN LOSS / HIGH PERFORMANCE

Welcome ODM / OEM



DAA-SHEEN TECHNOLOGY CO., LTD.  
Tel:+886-6-2631961 Fax:+886-6-2649685  
No.63, Sin-Lo Road, Tainan, Taiwan  
e-mail:daasheen@ms22.hinet.net  
http://www.daasheen.com  
© For more information, please contact us:



Finally, the common-mode rejection ratio (CMRR) can be found from:

$$CMRR = 20 \text{Log} \left| \frac{S_{21} + S_{31}}{S_{21} - S_{31}} \right|$$

The 0404 parts have a pin configuration similar to an LGA integrated circuit (IC). A 0.5-mm pitch allows just four pins on these parts. With only four pins, there is no separate DC-bias pin as common for Marchand type baluns (Fig. 4). However, by using a suitable capacitor to form an RF ground, these baluns can be used in applications requiring DC-bias through the part or for isolating a DC-bias present on the differential pair from ground. To provide the RF-ground, a capacitor must be selected that has a self-resonance above the frequency band of interest and a value sufficiently large as to not generate higher insertion loss and detune the performance. The baluns are wide-band, except for the lower differential impedances and thus are generally forgiving when DC-biased. An inductor is needed for feeding the bias, resonance free in the band of interest and with sufficient value to act as a choke.

The fundamental Marchand design equations are:

$$Z_0 = \sqrt{Z_{in} Z_{BalOut}}$$

$$Z_{0e} = Z_0 \sqrt{\frac{1+k}{1-k}}$$

$$Z_{0o} = Z_0 \sqrt{\frac{1-k}{1+k}}$$

where:

k = the voltage coupling ratio of the coupled sections and would be determined from the required bandwidth, etc.

If the internal ground reference is insufficient, the impedance of the balun will change, impacting performance. Equally important for good balun performance is a good RF ground on the balun's DC bias pin (pin 2). This provides the necessary reflections at the end of the coupled sections.

Since the small size of 0404 parts limits them to four pins, the functions of pins 2 and 5 have been brought together. When simulating the effects

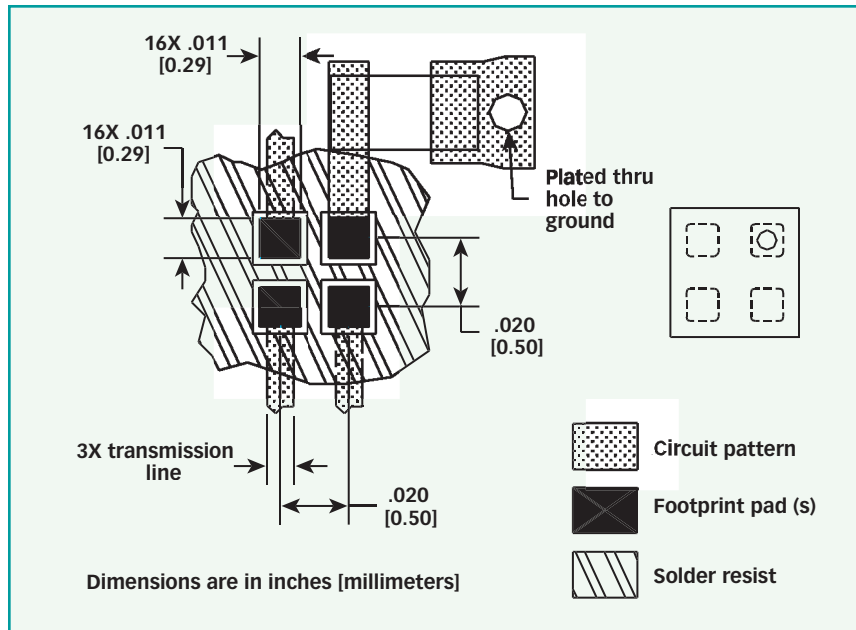

4. With only four pins because of their tiny footprint, the 0404 baluns lack a separate DC bias pin, although a capacitor at the RF ground port can feed DC bias.

of having an RF ground as opposed to separate RF and DC grounds, a four-port S-parameter model representation should be used (Fig. 5). This is no different from simulating the effects of a bias circuit on the traditional DC-bias pin on 0805 and 0603 baluns.

Simulations of performance have shown minimal improvement with capacitance values above 8 pF. This observation holds true for all other performance parameters, including balanced performance (not shown here). Simulation were based on 0201

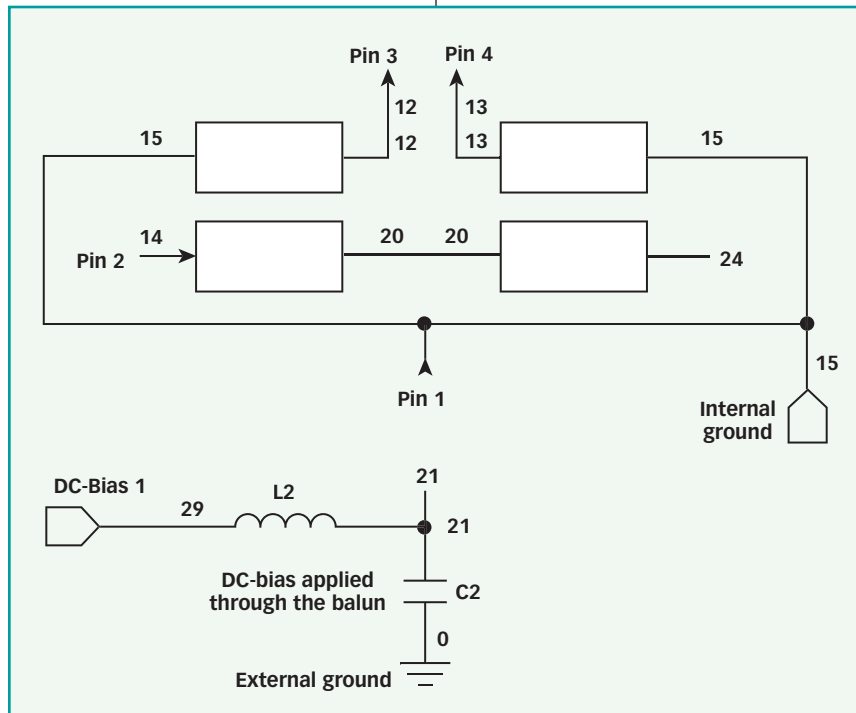

5. By using an external capacitor, it is possible to use one pin of the 0404 balun for DC bias and RF ground.

**Table 2: These capacitors were used when testing the BD2425N50100A00 balun for the results shown in Fig. 6**

CAPACITOR VALUE	CAPACITOR PART NUMBER	IDENTIFIER (IN FIG. 6)
No capacitor (DC grounded)	-	Capval=5
8.2 pF	0201ZK8R2BBW	Capval=7
10 pF	0201ZK100GBW	Capval=8
12 pF	0201ZK120GBW	Capval=9
10 pF +10 pF in parallel	0201ZK100GBW (2)	Capval=10

series capacitors from Murata (Smyrna, GA). Measurements were made using 0201 capacitors from AVX Corp. (Myrtle Beach, SC), although these were not used in the simulation and there is no direct correlation between the simulations and the measurements. For the conditions of **Table 2**, insertion loss ranged from 0.56 to 0.68 dB at 2.45 GHz (**Fig. 6**). Measurements showed that higher capacitance values were needed than those suggested by the simulations. Based on this comparison, balun users are advised to try capacitors from different vendors in the range shown in **Table 2**, and avoid using capacitance values much higher than needed since these can exhibit self-resonances that will degrade performance.

Simulated performance for the 5-GHz balun indicate that a 1.2-pF capacitor

does not provide enough capacitance for that balun, while a 3.2-pF capacitor provides too much capacitance. Similar to the BD2425N50100A00 part, the capacitor value for a preferred capacitor vendor will be slightly different than the simulation performed for the 5-GHz balun. In the above examples, 0201 capacitors were used. The performance of a DC-isolated configuration can be tested for both configurations by using test boards from Anaren.

Samples of the 0805 and 0603 devices are now available as well as various versions of the 0404 products. Custom impedances and package options are also available. **Anaren, Inc.**, 6635 Kirkville Rd., East Syracuse, NY 13057; (800) 411-6596, (315) 432-8909, FAX: (315) 432-0189, Internet: [www.anaren.com](http://www.anaren.com).

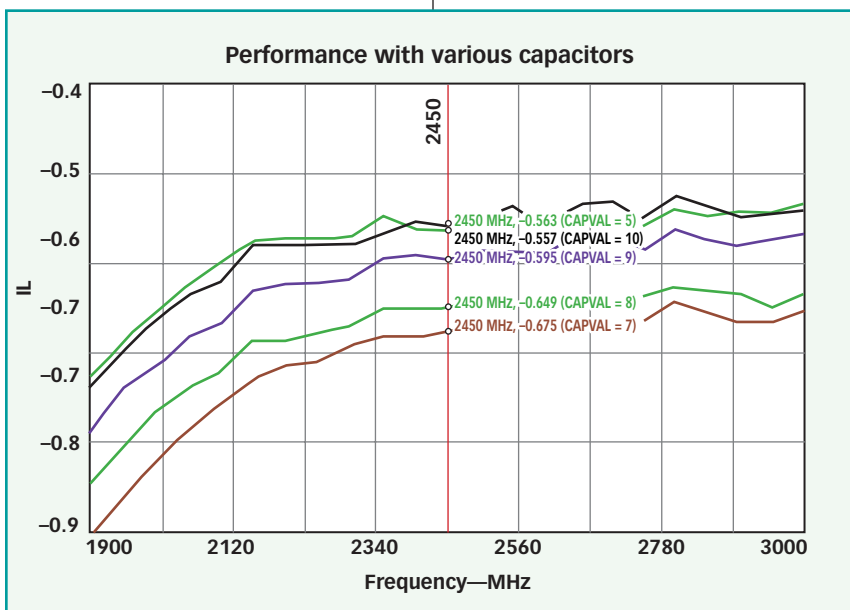

**6. The measured insertion loss of the model BD2425N50100A00 0404 balun is shown for a number of different capacitor values (listed in **Table 2**).**

(continued from p.72)

was taken on a 2-to-8-GHz DFD. In this case, the long delay was 7.81 ns and a 40-MHz system sampling clock was employed. The correlator output video bandwidth was set to 10 MHz. The minimum triggered RF pulse width was computed as 42.81 ns; the 100-percent POI pulse width then becomes 67.81 ns. Observing **Fig. 7**, when a threshold input signal (-60 dBm) is applied, the transition from the minimum triggered RF pulse width to 100-percent POI is almost linear. Increasing the RF input signal level improves the POI for short pulses, primarily because of video stretching at the higher RF input levels.

Finally, returning to **Fig. 6**, this computer program also calculated the lowest RF SNR such that, given that the input frequency is in the center of an output frequency cell, what is the minimum RF input SNR to assure that the data report is within that cell with probability 0.9. This appears in **Fig. 6** as I.

This proprietary computer program provides a huge boost in evaluating DFD designs. Once the required RF bandwidth and desired output frequency accuracy and resolution are established, the required delay time can be computed. This will then establish the number of correlators needed to produce the desired result.

Although the triggered DFD design, where frequency data is strobed synchronously with the RF envelope, produces the best combination of POI and minimum RF pulse width, most modern DFDs are clocked rather than triggered. In a clocked DFD design, the RF frequency is continuously sampled at fixed intervals. This permits synchronization of measured frequency data with RF amplitude and angle of arrival (AOA) data. The clocked design also supports synchronous RF SNR estimates internal to the DFD where, along with providing measured frequency data, the DFD simultaneously estimates RF SNR at the time of the RF frequency sample. Instantaneous estimation of the RF SNR eliminates the need for noise riding thresholds and supports other features, such as leading-edge pulse on pulse, or pulse on CW, triggering, and multipath blanking. **MRF**