



**DAC600**

## 12-Bit 256MHz Monolithic DIGITAL-TO-ANALOG CONVERTER

### FEATURES

- 12-BIT RESOLUTION
- 256MHz UPDATE RATE
- -73dB HARMONIC DISTORTION AT 10MHz
- LASER TRIMMED ACCURACY: 1/2LSB
- -5.2V SINGLE POWER SUPPLY
- EDGE-TRIGGERED LATCH
- LOW GLITCH: 5.6pVs
- WIDEBAND MULTIPLYING REFERENCE INPUT
- 50Ω OUTPUT IMPEDANCE

### DESCRIPTION

The DAC600 is a monolithic, high performance digital-to-analog converter for high frequency waveform generation. The internal segmentation and latching minimize output glitch energy and maximizes AC performance. Resistor laser trimming provides for excellent DC linearity.

The ECL compatibility provides for low digital noise at high update rates. The complementary 50Ω outputs and low output capacitance simplifies transmission line design and filtering at the output.

The DAC600 combines precision thin film and bipolar technology to create a high performance, cost effective solution for modern waveform synthesis.

### APPLICATIONS

- DIRECT DIGITAL SYNTHESIS
- ARBITRARY WAVEFORM GENERATION
- HIGH RESOLUTION GRAPHICS
- COMMUNICATIONS LOCAL OSCILLATORS
- Spread Spectrum/Frequency Hopping Base Stations
- Digitally Tuned Receivers

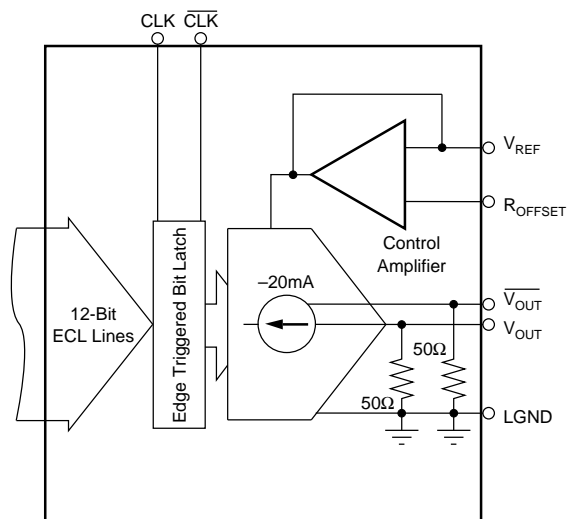

International Airport Industrial Park • Mailing Address: PO Box 11400 • Tucson, AZ 85734 • Street Address: 6730 S. Tucson Blvd. • Tucson, AZ 85706  
Tel: (520) 746-1111 • Twx: 910-952-1111 • Cable: BBRCORP • Telex: 066-6491 • FAX: (520) 889-1510 • Immediate Product Info: (800) 548-6132

# SPECIFICATIONS

## ELECTRICAL

At +25°C V<sub>REF</sub> = +1.0V, V<sub>EEA</sub> = V<sub>EED</sub> = -5.2V, unless otherwise noted.

PARAMETER	CONDITIONS	TEMP	DAC600AN			DAC600BN			UNITS
			MIN	TYP	MAX	MIN	TYP	MAX	
<b>DIGITAL INPUTS</b>									
Logic	12 Parallel Input Lines, ECL								Bits
Resolution					12	*	*	*	V
ECL Logic Input Levels: V <sub>IL</sub>	Logic "0"	Full	-1.48	-1.95	-2	*	*	*	μA
		Full			2	*	*	*	V
	Logic "1"	Full	-1.1	-0.75	0	*	*	*	μA
		Full			200	*	*	*	μA
<b>DIGITAL TIMING</b>									
Input Data Rate		Full	DC		256	*		*	MHz
CLK Pulse Width High or Low		Full	1.95			*			ns
Set-up Time		Full	1.5	1.0		*	*		ns
Hold Time (Referred to CLK)		Full	1.9	1.7		*	*		ns
Propagation Delay		Full		2		*	*		ns
<b>ANALOG OUTPUT</b>									
Bipolar Output Current	R <sub>L</sub> = 0Ω	Full	19	20	21	*	*	*	mA
Output Resistance		Full	47.5	50	52.5	49	*	51	Ω
Output Capacitance		Full		15			*		pF
<b>CONTROL AMPLIFIER</b>									
Input Resistance		Full		800			*		Ω
Full Power Bandwidth	-3dB	Full		10			*		MHz
Offset		+25°C		0	±1		0	±0.5	mV
Input Reference Range		Full	100mV		±1.25	*		*	V
<b>TRANSFER CHARACTERISTICS</b>									
Integral Linearity Error <sup>(1)</sup> : V <sub>OUT NOT</sub>	Best Fit Straight Line	+25°C		±0.012	±0.024		±0.006	±0.012	%FSR
		Full		±0.024	±0.036		±0.012	±0.024	%FSR
		+25°C			±0.1			±0.1	%FSR
Differential Linearity Error <sup>(1)</sup> : V <sub>OUT NOT</sub>		+25°C			±0.024			±0.012	%FSR
		Full			±0.036			±0.024	%FSR
		+25°C			±0.1%			±0.1%	%FSR
12-Bit Monotonicity		+25°C		Guaranteed			Guaranteed		
		Full		Typical			Guaranteed		
Output Offset Current: V <sub>OUT NOT</sub>	Bits 1-12 HIGH	+25°C		75	150		50	100	μA
		Full		57	150		50	100	μA
Gain Error <sup>(2)</sup>		+25°C		±0.5	±1.5		±0.5	±1.0	%
		Full		±1.3	±2.0		±1.1	±2.0	%
Output Leakage Current	V <sub>REF</sub> = 0V, Bits 1-12 LOW, V <sub>OUT NOT</sub>	+25°C		10	75		5	50	μA
<b>TIME DOMAIN PERFORMANCE</b>									
Glitch Energy	Major Carry	+25°C		5.6			*		pVs
Fall Time	90% to 10%	+25°C		510			*		ps
Rise Time	10% to 90%	+25°C		770			*		ps
Settling Time <sup>(3)</sup>									
±0.1% FSR	Major Carry, 1 LSB Change	Full		4			*		ns
±0.024% FSR		Full		15			*		ns
<b>DYNAMIC PERFORMANCE</b>									
Spurious Free Dynamic Range <sup>(4)</sup>									
f <sub>O</sub> = 1MHz	f <sub>CLOCK</sub> = 50MHz	+25°C		74		70	77		dBFS <sup>(3)</sup>
f <sub>O</sub> = 10MHz	f <sub>CLOCK</sub> = 50MHz	+25°C		71		65	73		dBFS
f <sub>O</sub> = 1MHz	f <sub>CLOCK</sub> = 100MHz	+25°C		72		70	75		dBFS
f <sub>O</sub> = 10MHz	f <sub>CLOCK</sub> = 100MHz	+25°C		71		66	70		dBFS
f <sub>O</sub> = 20MHz	f <sub>CLOCK</sub> = 100MHz	+25°C		63		59	62		dBFS
f <sub>O</sub> = 10MHz	f <sub>CLOCK</sub> = 200MHz	+25°C		66		66	70		dBFS
f <sub>O</sub> = 20MHz	f <sub>CLOCK</sub> = 200MHz	+25°C		58		64	67		dBFS
f <sub>O</sub> = 50MHz	f <sub>CLOCK</sub> = 200MHz	+25°C		52		50	55		dBFS
Output Noise	Bits 1-12 HIGH	+25°C		10.6			*		nV/√Hz
<b>POWER SUPPLIES</b>									
Supply Voltages: V <sub>EE</sub>		Full	-4.5	-5.2	-5.5	*	*	*	V
Supply Currents: I <sub>EEA</sub>	Pins 33 and 34	Full	30	46	60	*	*	*	mA
	Pins 5 and 55	Full	110	150	190	*	*	*	mA
Power Consumption	Operating	Full		900mW	1.3		*	*	W
<b>TEMPERATURE RANGE</b>									
Specification: DAC600AN, BN	Ambient	Full	-40		+85	*	*	*	°C
θ <sub>JA</sub>				30					°C/W

NOTES: (1) Linearity tests are measured into a virtual ground (op amp). (2) Gain error in % is calculated by:  $GE (\%) = \frac{V_{MEASURED} (FS) - V_{IDEAL} (FS)}{V_{IDEAL} (FS)} \times 100$

(3) Settling time is influenced by the load due to fast edge speeds. Use good transmission line techniques

for best results. (4) Spurious free dynamic range is measured from the fundamental frequency to any harmonic or non-harmonic spurs within the bandwidth f<sub>CLK</sub>/2C<sub>L</sub>, unless otherwise specified.

## ORDERING INFORMATION

MODEL	DESCRIPTION	TEMPERATURE RANGE (AMBIENT)
DAC600AN, BN	68-Pin Plastic QUAD	-40°C to +85°C

## ABSOLUTE MAXIMUM RATINGS

$V_{EEA}$ .....	0.3 to -7
$V_{EED}$ .....	0.3 to -7
Logic Inputs .....	0 to -5.5V
Reference Input Voltage .....	0 to +1.25V
Reference Input Current .....	0 to 1.56mA
Case Temperature .....	-40°C to +125°C
Junction Temperature .....	+150°C
Storage Temperature .....	-55°C to +125°C
Lead Temperature (soldering, 10s) .....	+300°C

Stresses above these ratings may permanently damage the device.

## ELECTROSTATIC DISCHARGE SENSITIVITY

This integrated circuit can be damaged by ESD. Burr-Brown recommends that all integrated circuits be handled with appropriate precautions. Failure to observe proper handling and installation procedures can cause damage.

ESD damage can range from subtle performance degradation to complete device failure. Precision integrated circuits may be more susceptible to damage because very small parametric changes could cause the device not to meet its published specifications.

## PACKAGE INFORMATION

MODEL	PACKAGE	PACKAGE DRAWING NUMBER <sup>(1)</sup>
DAC600AN, BN	68-Pin Plastic QUAD	312-1

NOTE: (1) For detailed drawing and dimension table, please see end of data sheet, or Appendix D of Burr-Brown IC Data Book.

## PIN DEFINITIONS

PIN NO	DESIGNATION	DESCRIPTION	PIN NO	DESIGNATION	DESCRIPTION
1	BYPASS	Disables Latching of Data	35	$V_{REF2}$	Analog Reference Voltage Center Tap
2	CLK	CLOCK	36	NC	
3	CLKNOT	CLOCKNOT	37	NC	
4	DGND	Digital Ground	38	$V_{REF}$	Analog Reference Voltage
5	$DV_{EE}^{(1)}$	-5.2V Supply	39	$V_{REF}$	Analog Reference Voltage
6	Bit 9		40	NC	
7	Bit 10		41	NC	
8	Bit 11		42	$R_{OFFSET}$	Offset Compensation
9	Bit 12	LSB	43	NC	
10	NC		44	BYPASS	0.1 $\mu$ F Bypass to Ground
11	NC		45	NC	
12	NC		46	NC	
13	$V_{OUT}$	DAC Output	47	ALTCOMPC	Control Amp PTAT Reference Compensation <sup>(2)</sup>
14	$V_{OUT}$	DAC Output	48	AGND	Analog Signal Ground
15	LGND	Ladder Ground	49	NC	
16	LGND	Ladder Ground	50	LBIAS	Ladder Bias Alternate Compensation <sup>(2)</sup>
17	$V_{OUTNOT}$	DAC Output Complement	51	NC	
18	$V_{OUTNOT}$	DAC Output Complement	52	NC	
19	NC		53	NC	
20	AGND	Analog Ground	54	Bit 1	MSB
21	NC		55	$DV_{EE}$	Digital -5.2V Supply
22	NC		56	DGND	Digital Signal Ground
23	NC		57	DGND	Digital Signal Ground
24	NC		58	Bit 2	
25	NC		59	Bit 3	
26	BYPASS	0.1 $\mu$ F Bypass to Ground	60	Bit 4	
27	NC		61	NC	
28	ALTCOMPIB	PTAT-IB Reference Compensation <sup>(2)</sup>	62	Bit 5	
29	AGND	Analog Ground	63	DGND	Digital Ground
30	AGND	Analog Ground	64	Bit 6	
31	NC		65	Bit 7	
32	LOOPCRNT	DAC Reference Alt. Loop Current (Connect to AGND)	66	DGND	Digital Ground
33	$V_{EE}^{(1)}$	-5.2V Supply	67	Bit 8	
34	$V_{EE}^{(1)}$	-5.2V Supply	68	NC	

NC: no connect

NOTE: (1) Pins 5 and 55 typically draw 150mA of current. Pins 33 and 34 combined typically draw 46mA. (2) Connect bypass capacitor to  $V_{EE}$ .

The information provided herein is believed to be reliable; however, BURR-BROWN assumes no responsibility for inaccuracies or omissions. BURR-BROWN assumes no responsibility for the use of this information, and all use of such information shall be entirely at the user's own risk. Prices and specifications are subject to change without notice. No patent rights or licenses to any of the circuits described herein are implied or granted to any third party. BURR-BROWN does not authorize or warrant any BURR-BROWN product for use in life support devices and/or systems.

## DICE INFORMATION

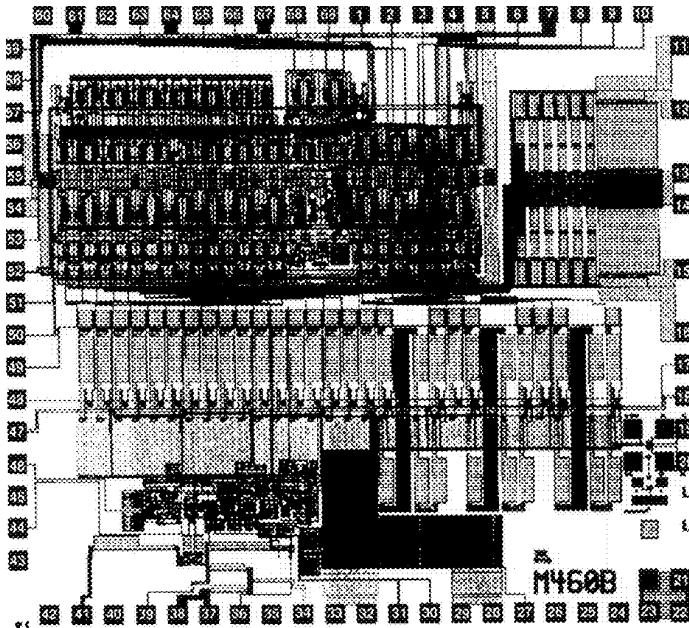

**DAC600 DIE TOPOGRAPHY**

### MECHANICAL INFORMATION

	MILS (0.001")	MILLIMETERS
Die Size	160 x 140 ±5	4.06 x 3.56 ±0.13
Die Thickness	20 ±3	0.51 ±0.08
Min. Pad Size	4 x 4	0.10 x 0.10
Backing	Gold	
Metallization	Gold	

PAD	FUNCTION	PAD	FUNCTION
1	Bypass	36	NC
2	CLK	37	V <sub>REF</sub>
3	CLKNOT	38	V <sub>REF</sub>
4	DGND	39	NC
5	DV <sub>EE</sub>	40	NC
6	Bit 9	41	R <sub>OFFSET</sub>
7	NC	42	NC
8	Bit 10	43	NC
9	Bit 11	44	NC
10	Bit 12	45	NC
11	V <sub>OUT</sub>	46	ALTCOMPC
12	V <sub>OUT</sub>	47	AGND
13	LGND	48	NC
14	LGND	49	LBIAS
15	V <sub>OUTNOT</sub>	50	NC
16	V <sub>OUTNOT</sub>	51	NC
17	NC	52	NC
18	AGND	53	Bit 1 (MSB)
19	NC	54	DV <sub>EE</sub>
20	NC	55	DGND
21	NC	56	DGND
22	NC	57	Bit 2
23	NC	58	Bit 3
24	NC	59	Bit 4
25	NC	60	NC
26	NC	61	NC
27	ALTCOMPIB	62	NC
28	AGND	63	Bit 5
29	AGND	64	DGND
30	NC	65	Bit 6
31	LOOPCRNT	66	Bit 7
32	AV <sub>EE</sub>	67	DGND
33	AV <sub>EE</sub>	68	Bit 8
34	V <sub>REF2</sub>	69	NC
35	NC		

**Substrate Bias:** Negative Supply  $-V_{CC}$ .  
 NC = Do not connect.

# TYPICAL PERFORMANCE CURVES

AT  $T_{CASE} = +25^{\circ}C$ ,  $V_{REF} = +1.0V$ , measured at  $V_{OUT NOT}$ . Spurious free dynamic range includes all harmonic or non-harmonic spurs in the bandwidth  $f_{CLK}/2$ , unless otherwise noted.

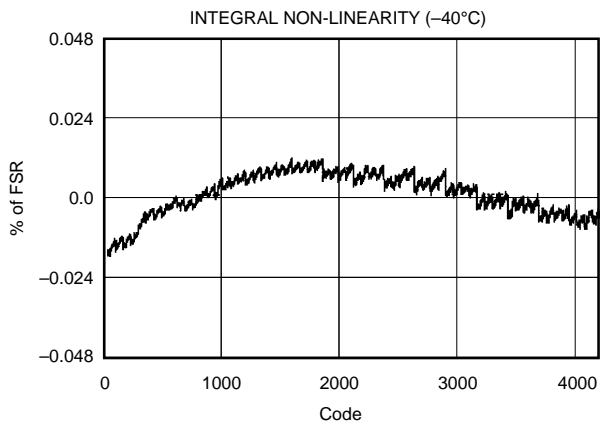
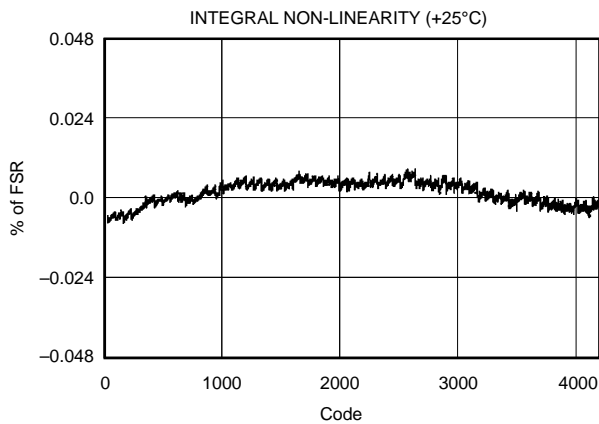
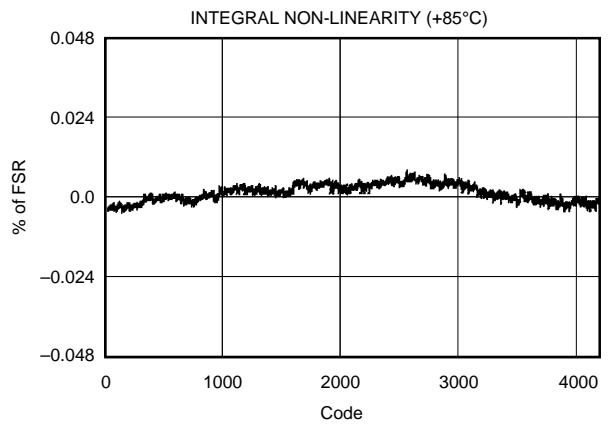
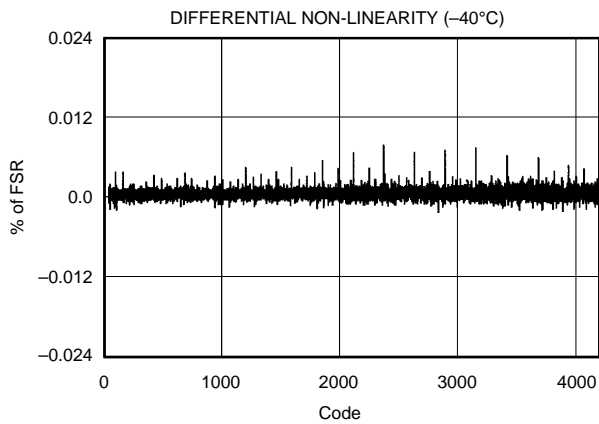
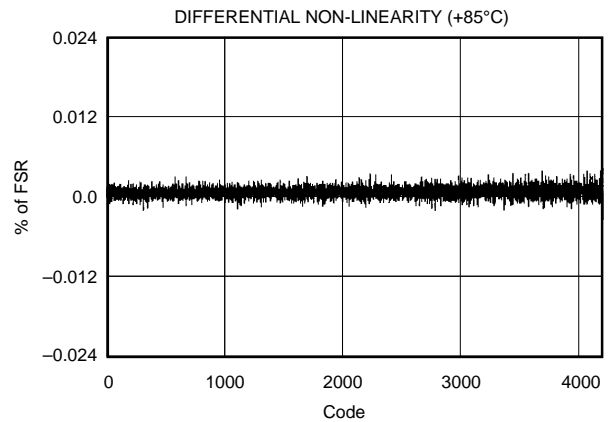
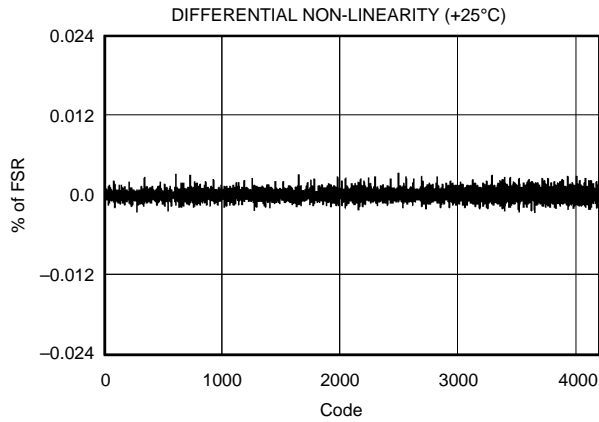

# TYPICAL PERFORMANCE CURVES (CONT)

$T_{CASE} = +25^{\circ}C$ ,  $V_{REF} = +1.0V$ , measured at  $V_{OUTNOT}$ . Spurious free dynamic range includes all harmonic or non-harmonic spurs in the bandwidth  $f_{CLK}/2$ , unless otherwise noted.

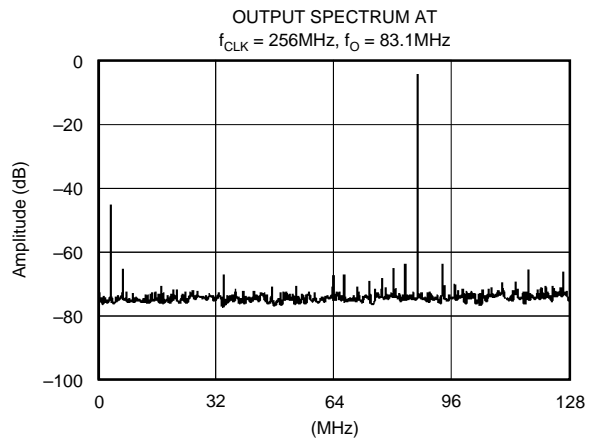
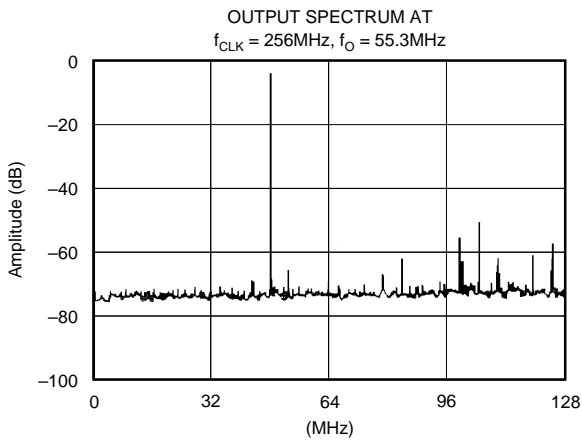
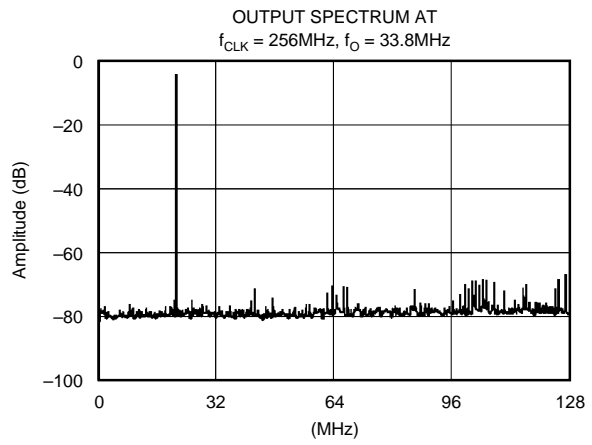
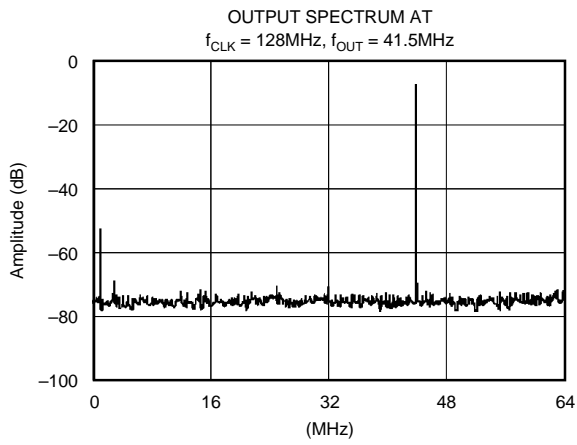
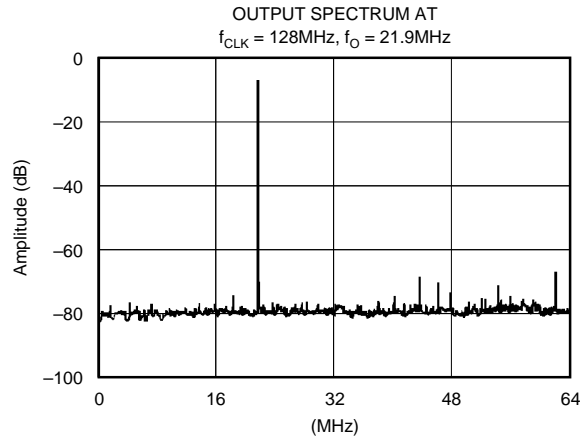
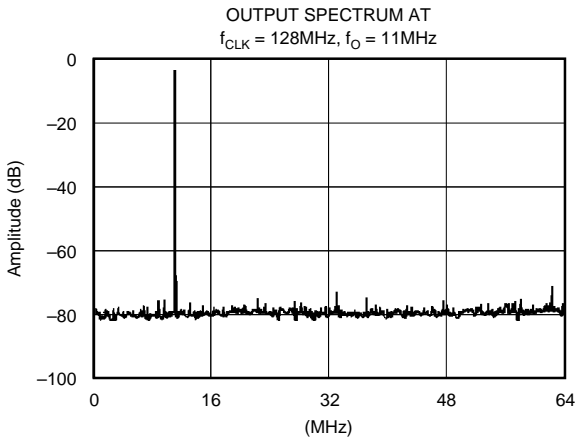

# TYPICAL PERFORMANCE CURVES (CONT)

At  $T_{CASE} = +25^{\circ}C$ ,  $V_{REF} = +1.0V$ , measured at  $V_{OUT NOT}$ . Spurious free dynamic range includes all harmonic or non-harmonic spurs in the bandwidth  $f_{CLK}/2$ , unless otherwise noted.

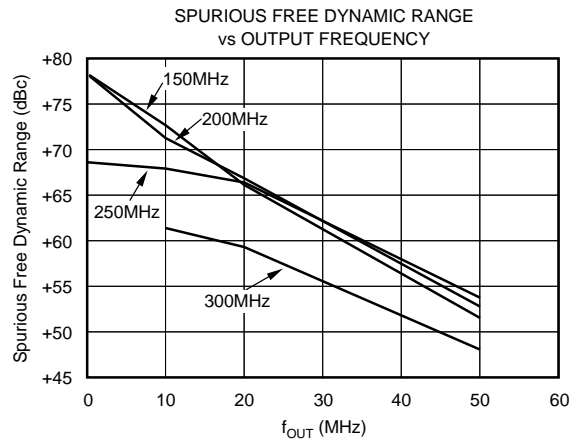
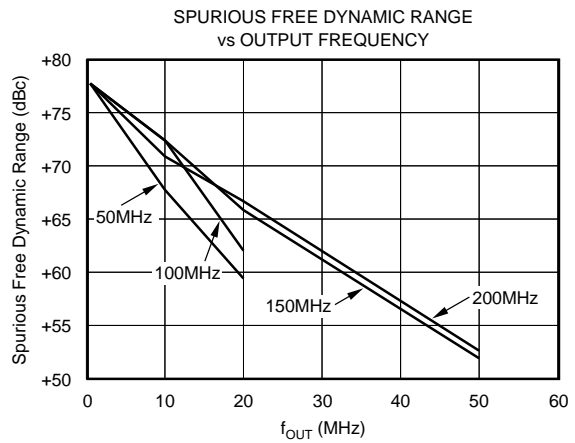
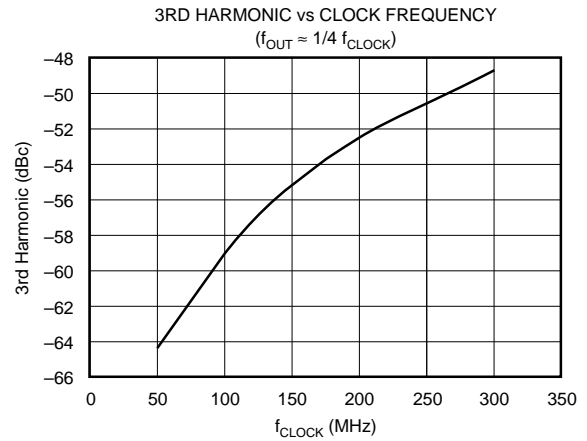
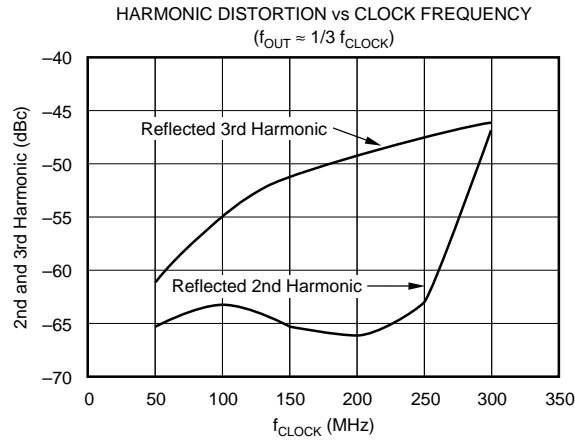
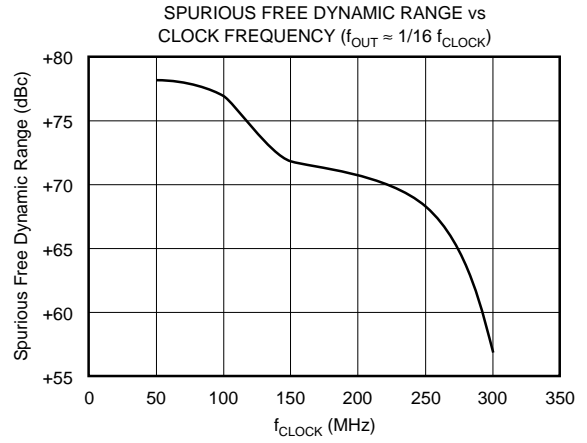
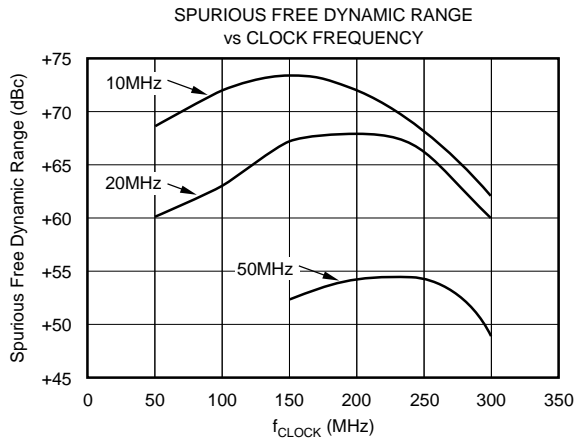

# TYPICAL PERFORMANCE CURVES (CONT)

At  $T_{CASE} = +25^{\circ}C$ ,  $V_{REF} = +1.0V$ , measured at  $V_{OUT NOT}$ . Spurious free dynamic range includes all harmonic or non-harmonic spurs in the bandwidth  $f_{CLK}/2$ , unless otherwise noted.

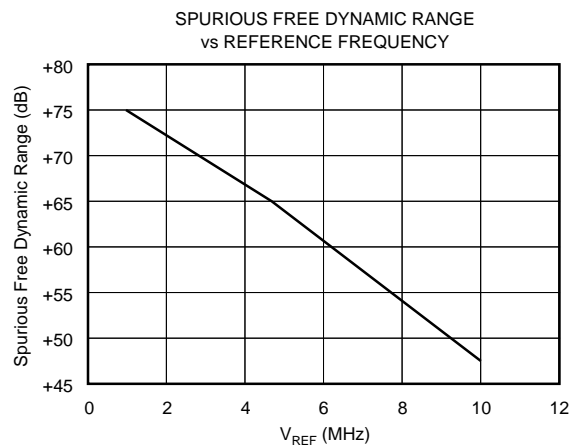
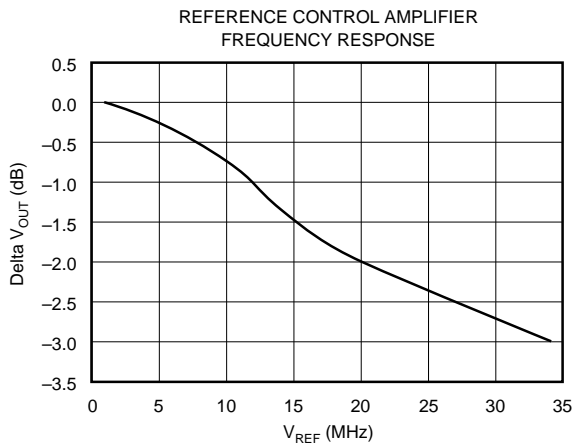
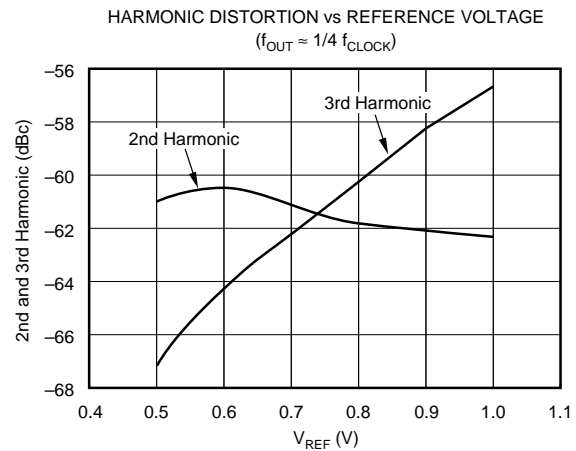
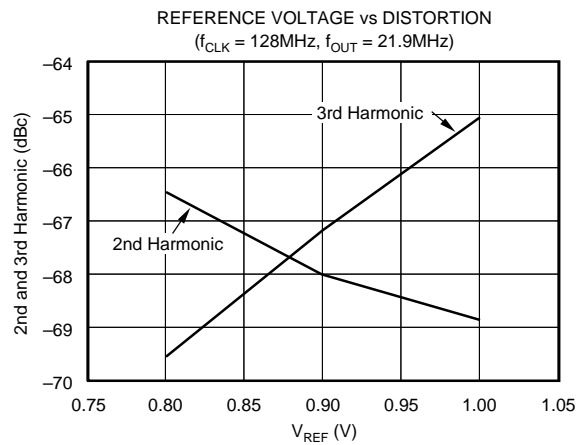
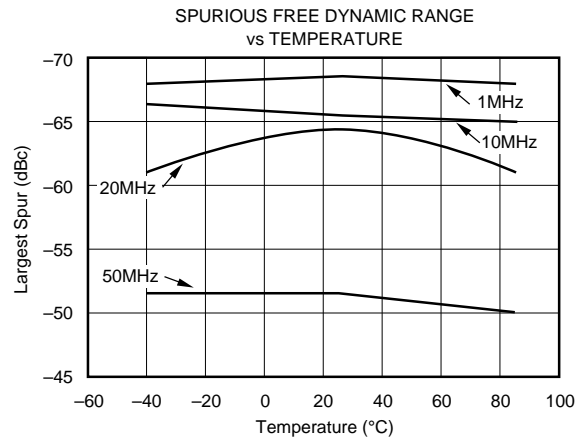
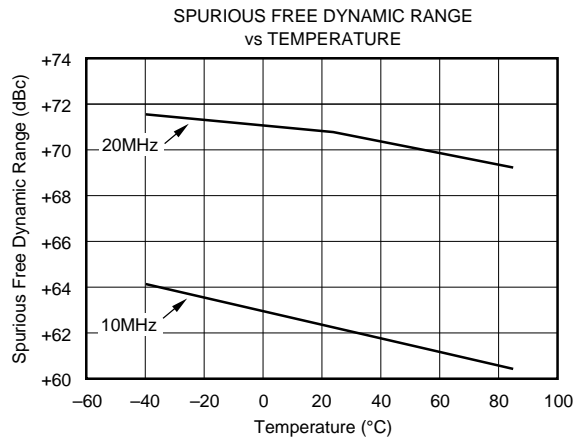

$V_{REF}$  Amplitude +0.75V DC 100mVp-p AC  
(All Bits on, 47pF Pin 35)

$V_{REF}$  Amplitude +0.75V DC 100mVp-p AC  
(All Bits on, 47pF Pin 35)

# THEORY OF OPERATION

The DAC600 employs a familiar architecture where input bits switch on the appropriate current sources (Figure 1.) Bits 1-4 are decoded into 15 segments after the first set of latches. The edge triggered master-slave latches are driven by an internal clock buffer. Current sources for bits 5 and 6 are scaled down in binary fashion. These current sources are switched directly to the output of the R-2R ladder. Bits 7-12 are properly scaled and fed to the laser trimmed R-2R ladder.

Decoding of bits 1-4 into 15 segments and synchronizing the data with a master/slave register reduces glitching. If the BYPASS input is low, data is transferred to the output on the positive going edge of the clock. If BYPASS is high, data is transferred to the output regardless of clock state. All digital inputs are ECL compatible.

The output current sees 50Ω of output impedance from the equivalent resistance of a R-2R ladder. With all of the current sources off, the output voltage is at 0V. With all current sources on (-20mA), the output voltage is at -1V. Transfer function information is given in Tables I and II.

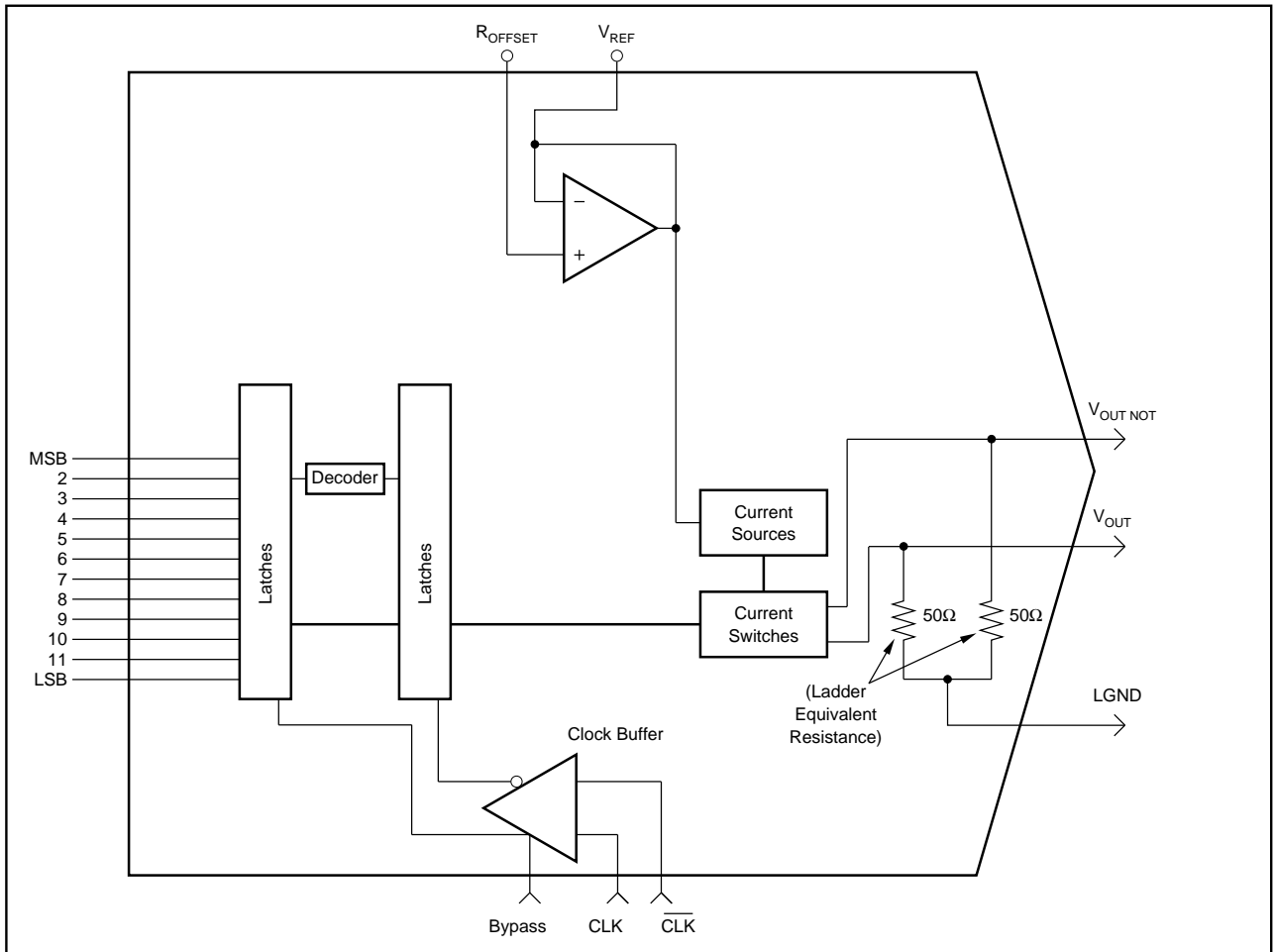

FIGURE 1. Basic DAC600 Architecture.

INPUT BITS 1 2 3 4 5 6 7 8 9 10 11 12	OUTPUT VOLTAGES	
	$V_{OUT}$	$NV_{OUT}$
0 0 0 0 0 0 0 0 0 0 0 0	0V	-0.999756V
0 0 0 0 0 0 0 0 0 0 0 1	-244μV	0.999512V
•	•	•
•	•	•
•	•	•
1 0 0 0 0 0 0 0 0 0 0 0	-0.5	-0.499756
1 1 1 1 1 1 1 1 1 1 1 1	-0.999756V	0

TABLE I. Input Code vs Output Voltage Relationships.

BIT	VOLTAGE (No External Load, $V_{OUT}$ )
1	-0.5
2	-0.25
3	-0.125
4	-62.5mV
5	-31.25mV
6	-15.625mV
7	-7.8125mV
8	-3.9063mV
9	-1.9531mV
10	-976μV
11	-488μV
12 (LSB)	-244μV

TABLE II. Nominal Bit Weight Values.

There is also a complementary  $V_{OUT\_NOT}$  output that allows for a differential output signal. The full scale complementary outputs ( $V_{OUT}$  and  $V_{OUT\_NOT}$ ) can be simply modeled as  $-20\text{mA}$  in parallel with  $50\Omega$ . This gives an output swing of  $0.5\text{Vp-p}$  with an external  $50\Omega$  load.

### REFERENCE/GAIN ADJUSTMENT

The  $V_{REF}$  pin should be supplied by a  $+1.0\text{V}$  reference that is capable of supplying a nominal current of  $1.25\text{mA}$ . An alternative would be the use of a  $1.25\text{mA}$  current source. A low drift reference will minimize gain drift. A recommended reference circuit is given in Figure 2 as shown in the Typical Performance Curves, lowering the reference voltage to  $+0.8\text{V}$  will typically improve the Spurious Free Dynamic Range by a few dB.

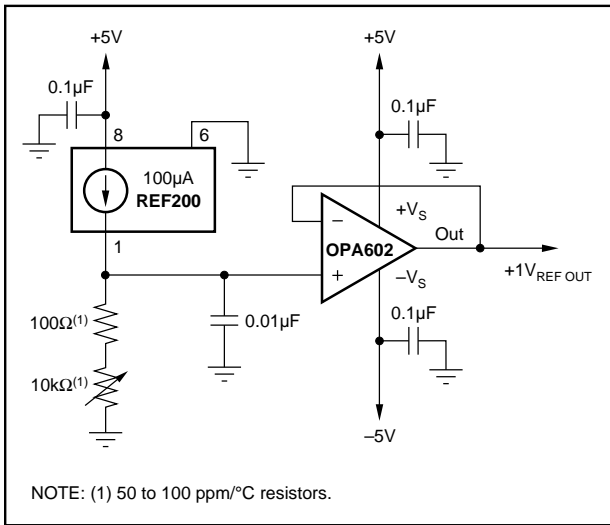

FIGURE 2. A Low Drift External Reference Circuit.

A low-cost alternative reference circuit is shown in Figure 3. This circuit uses the Burr-Brown REF1004-2.5 micropower voltage reference. Gain drift is dependent upon the temperature coefficient of the  $1.2\text{k}\Omega$  resistor. A TC of  $< 10\text{ppm}/^\circ\text{C}$  is recommended.

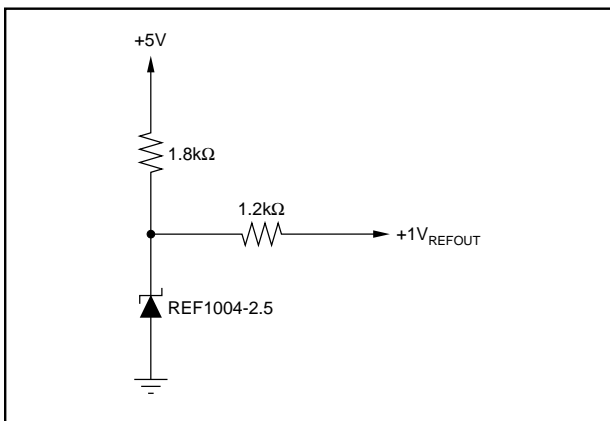

FIGURE 3. Low Cost External Reference Circuit.

The DAC600 can also accept a wideband multiplying reference input. The full power bandwidth of this reference is approximately  $30\text{MHz}$ . Care must be taken not to exceed the minimum and maximum input reference voltage levels which are  $100\text{mV}$  and  $+1.25\text{V}$  respectively (refer to the absolute maximum ratings section). In the multiplying reference mode, the  $0.4\mu\text{F}$  bypass capacitor on LBIAS and the  $0.1\mu\text{F}$  on pin 35 need to be removed. A  $47\text{pF}$  capacitor to ground needs to be connected to pin 35 (Figure 4).

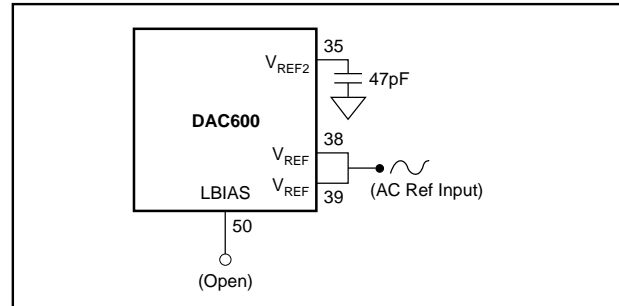

FIGURE 4. Connections for a Multiplying Reference Input.

### TIMING

The DAC600 has an internal latch that is triggered on the rising edge of the clock when the BYPASS pin is set LOW. This master-slave mode of operation will assure that the 12 bits will arrive at the current sources with a minimum of data skew. Therefore, this mode is recommended for the vast majority of applications. Observing the minimum set-up and hold time recommendations will ensure proper data latching, refer to Figure 5 for complete timing specifications.

When BYPASS is set HIGH, the DAC600 will operate in the transparent mode. In this mode, both the master and slave registers are transparent and changes in input data ripple directly to the output. Since the four MSBs have a decoder delay, these bits arrive at the output approximately  $600$  picoseconds later than the lower 8 LSBs. Because this data skew causes glitch, this mode is not recommended for optimum AC performance.

The DAC600 has a differential ECL clock input. This clock input can also be driven by a single ended clock if desired by trying the CLKNOT input to an external voltage of  $-1.3\text{V}$ . Using a differential clock provides much improved digital feedthrough immunity, however.

### DRIVING THE DAC600

The DAC600 inputs will most likely be driven by high speed ECL gate outputs. These outputs should be terminated using standard high speed transmission line techniques. Consult an ECL handbook for proper methods of termination.

Termination resistors should not be connected to the analog ground plane close to the DAC600. The fast changing digital bit currents will cause noise in the analog ground plane under this layout scheme. These fast changing digital currents should be steered away from the sensitive DAC600

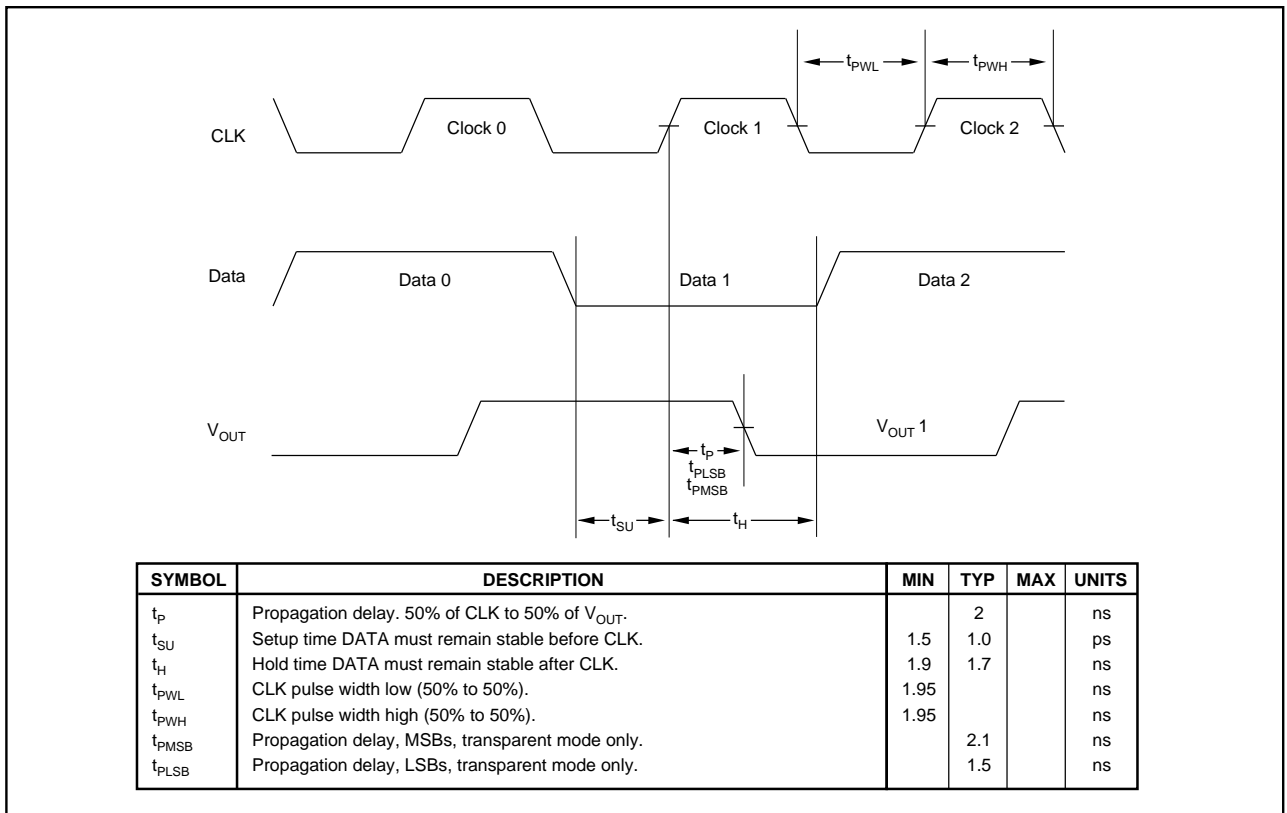

FIGURE 5. Timing Diagram.

analog ground plane. For speeds of up to 256MHz, series termination with 47Ω resistors will be adequate (Figure 6). This termination technique will greatly lessen the issue of termination currents coupling into the analog ground plane. This is shown in the typical DAC600 connection diagram (Figure 7.)

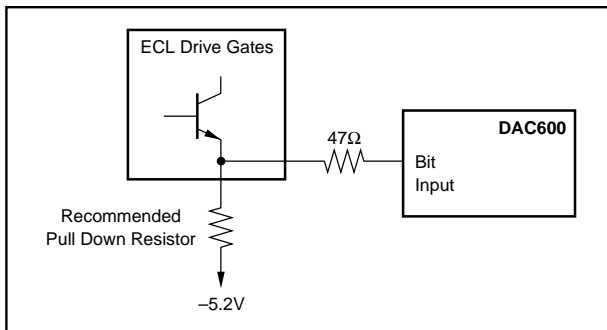

FIGURE 6. Series Bit Termination.

## LAYOUT AND POWER SUPPLIES

A multilayer PC board with a solid ground and power planes is recommended. All of the ground pins (both analog and digital) should be connected directly to the analog ground plane at the DAC600.

Wide busses for the power paths are recommended as good general practice. External bypassing is recommended. A 10μF ceramic capacitor in parallel with a 0.01μF chip capacitor will be sufficient in most applications.

ALTCOMP<sub>B</sub> and ALTCOMP<sub>C</sub> should be bypassed with 0.1μF capacitors connected to V<sub>EEA</sub>. When not used in the multiplying mode LBIAS should be bypassed with a 0.4μF capacitor connected to V<sub>EEA</sub>. The heat spreader (pins 26 and 44) should be bypassed with a 0.1μF capacitor.

## MAXIMIZING PERFORMANCE

In addition to optimizing the layout and ground of the DAC600, there are other important issues to consider when optimizing the performance of this DAC in various AC applications.

The DAC600 includes an internal 50Ω output impedance to simplify output interfacing to a 50Ω load. Because some loads may be a complex impedance, care must be taken to match the output impedance with the load. Mismatching of impedances can cause reflections which will affect the measured AC performance parameters such as settling time, harmonic distortion, rise/fall times, etc. Often complex impedances can be matched by placing a variable 3 to 10pF capacitor at the output of the DAC to ground. Also, probing the output of the DAC can present a complex impedance.

The typical performance curves of Spurious Free Dynamic Range vs various combinations of clock rate and/or input frequency should give a general idea of the spectral performance of the DAC under system specific clock and output frequencies. For variable frequency DDS and ARB applications, having a programmable frequency bandpass (smart) filter at the output of the DAC can greatly improve system

spur and noise performance by filtering out unwanted spur and noise spectra. Even with a programmable bandpass filter, care should be taken to update the DAC at greater than 4 times per cycle to (1) minimize the 2nd and 3rd harmonic magnitudes by having the output slew excessively between any successive clock and (3) to keep the 2nd harmonic and other even order harmonics from folding back close to the fundamental under the condition  $f_{OUT} = 1/3 f_{CLK}$  and (3) to keep the 3rd harmonic and other harmonics from folding back close to the fundamental under the condition

$f_{OUT} = 1/4 f_{CLK}$ . The making use of the high update rate of the DAC600 helps to lessen the problems of large harmonics “folding back” into the passband.

For DDS applications, often the DAC itself is the limit in Spurious Free Dynamic Range (SFDR) performance. However, due to the high linearity of the DAC600, low frequency spurious performance may be limited by the digital truncation error of the phase accumulator/ROM combination. Most vendors supplying a combination of phase accumulator and ROM specify the SFDR of their digital algorithm.

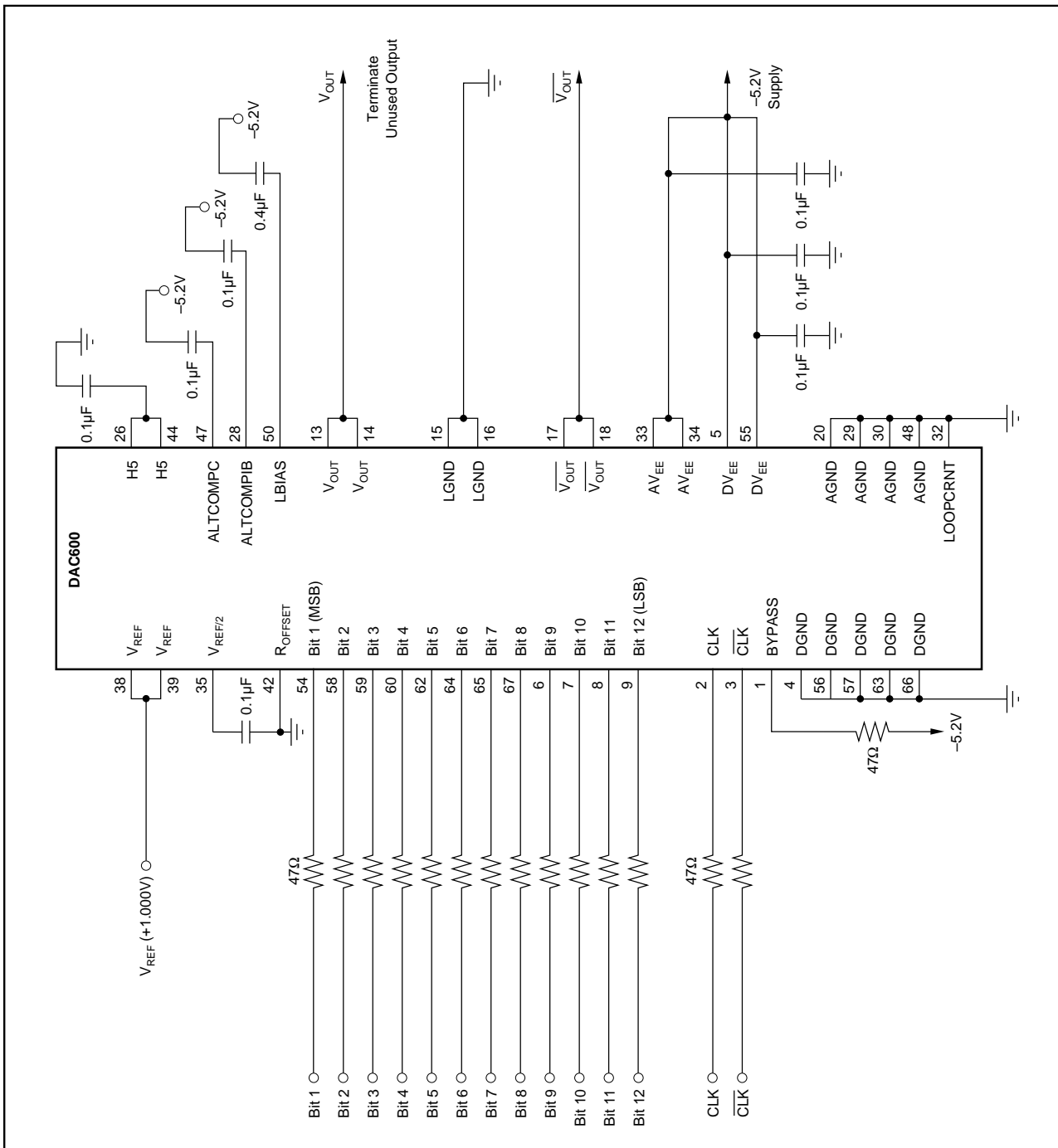

FIGURE 7. Typical DAC600 Connection Diagram.