

# SCDIPOL

Isolated POL (iPOL) Series

## DC-DC Converters

---

### Features

- Voltage Range
  - $V_{IN}$ : 26.0V<sub>DC</sub> to 48.0V<sub>DC</sub>
  - $V_{OUT}$ : 0.65V<sub>DC</sub> to 48.00V<sub>DC</sub>
- Typical Applications:
  - For  $V_{OUT}$  = 0.65V to 48.0 V
- High Efficiency (>90%)
- High Density (up to 162W/in<sup>3</sup>)
- Provide Enable/Disable Control
- Zero Voltage Switching / Zero Current Switching (ZVS/ZCS) Quasi-Resonant Converter Topology
- Contains Built-in Protection Features
  - Input Over/Under-voltage Shutdown
  - Short Circuit Protection
- Package: Gull Winged Power Package
- MIL-PRF-38534 Class L Qualification Pending

### Operational Environment

- Temperature Range: -40°C to +125°C
- Total Dose: 100 krad(Si)
- SEL Immune: >80 MeV-cm<sup>2</sup>/mg

### Applications

- Low voltage, high current digital systems
- Sensitive low noise high speed ADC and DAC
- RF power

### Introduction

The CAES iPOLs (isolated Point of Load) Modules excel at speed, density, and efficiency to meet the demands of advanced power applications while providing isolation from input to output.

The output voltage of the iPOL tracks its input voltage with a voltage ratio K factor ( $V_{in} \times K = V_{out}$ ). These units deliver up to 50A of current with unprecedented efficiency and the smallest footprint in the industry for a radiation hard Point Of Load Converter. Paralleling units delivers even higher power levels.

This iPOLs are available in two types of power packages (613xxx and 612xxx) compatible with standard Hi-Rel manual surface mount assembly processes. The fast dynamic response and low noise performance of the these iPOLs eliminate the need for excessive bulk capacitance at the load, substantially increasing system density while improving reliability and decreasing non-recurring cost.

# SCDIPOL

Isolated POL (iPOL) Series

## DC-DC Converters

### Application Examples

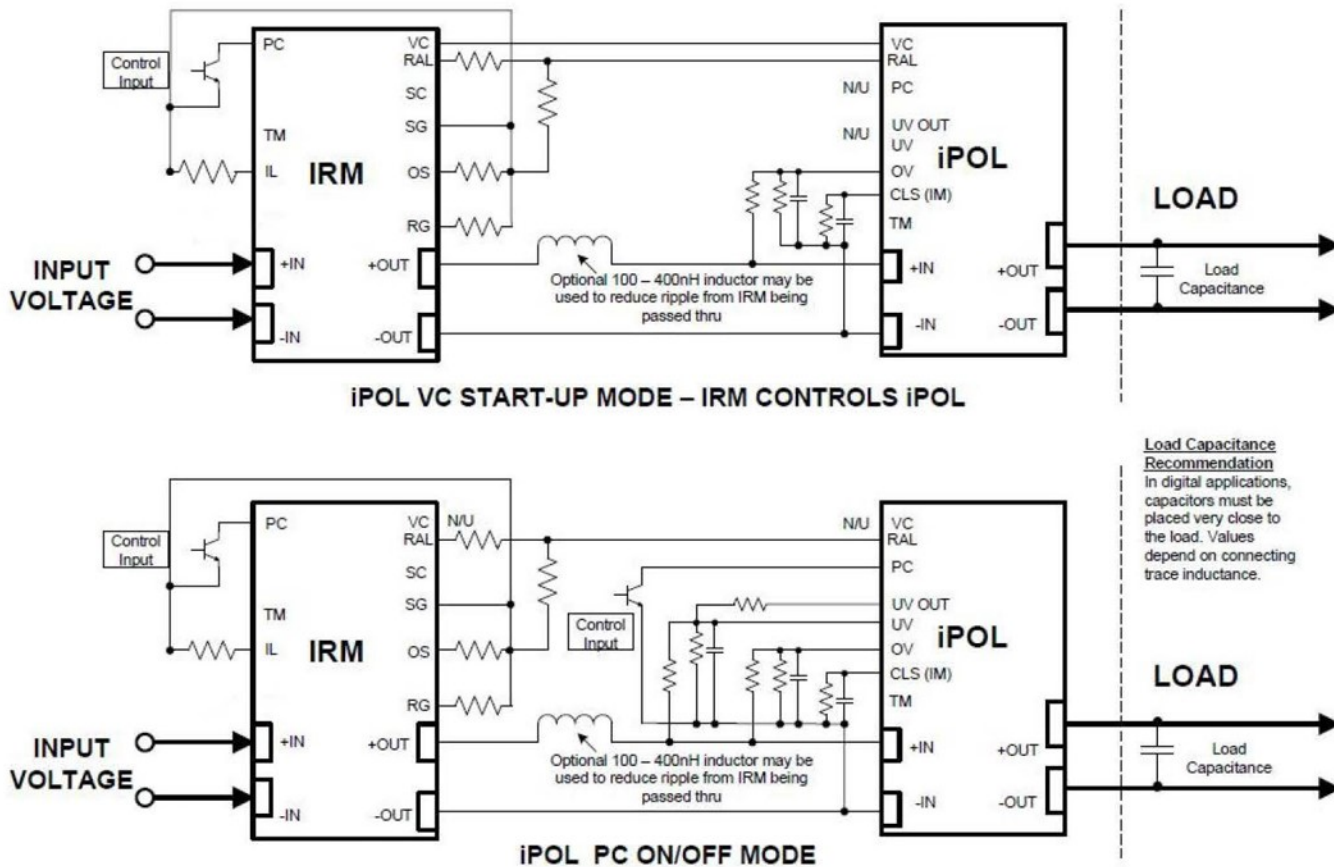

Figure 1: Typical Applications;  
613xxx Modules Use VC Start-Up Mode;  
612xxx Modules use either PC On/Off Mode or Self Start Mode (PC Pin Float, No connect VC Pin)

# SCDIPOL

Isolated POL (iPOL) Series

# DC-DC Converters

## Detailed Block Diagram

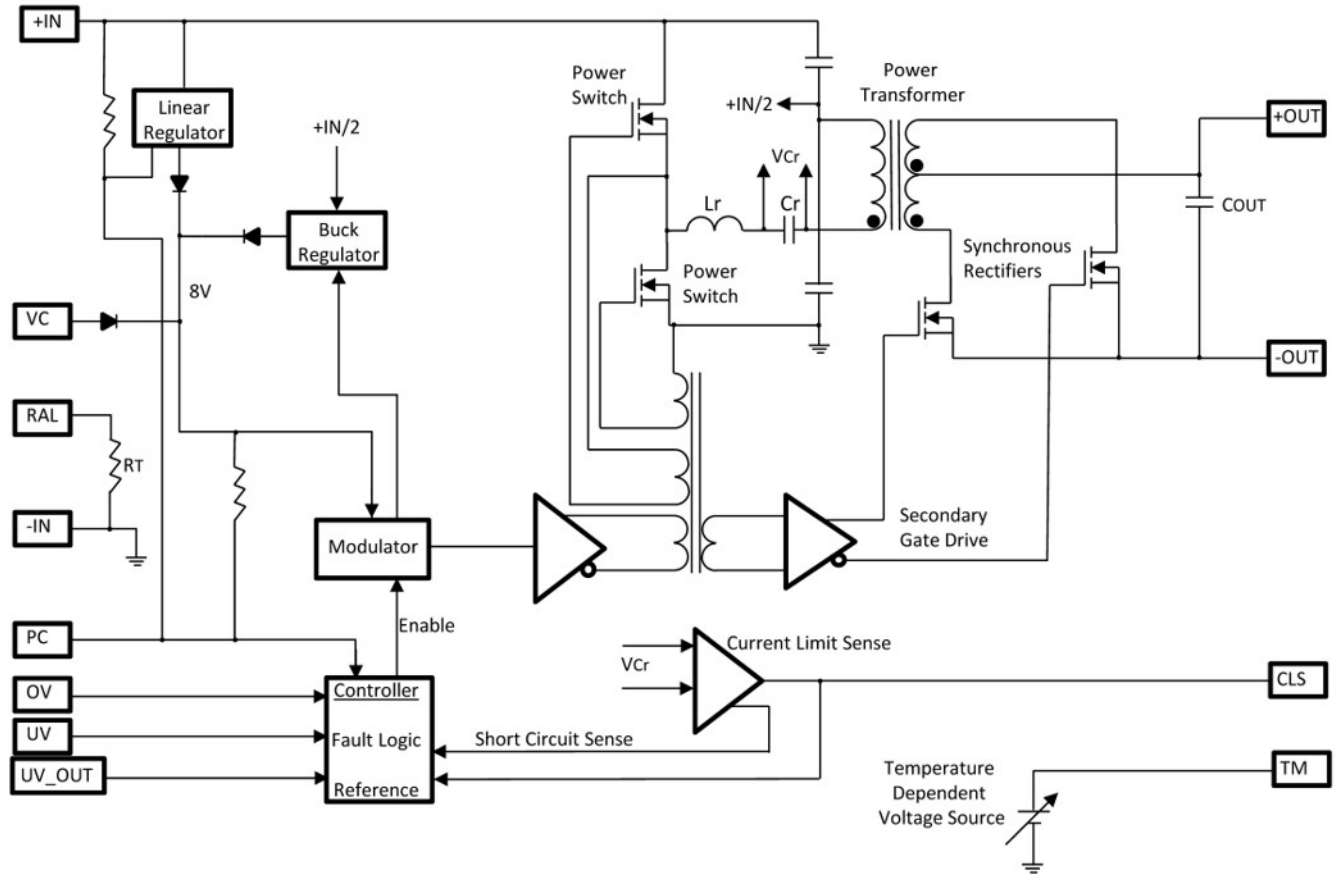

Figure 2: Detailed Block Diagram

## SCDIPOL

Isolated POL (iPOL) Series

## DC-DC Converters

## Pinlist

Table 1: PIN Numbers and Names for 612XXX iPOLs

Pin No.	Signal	Pin No.	Signal
1	+IN	24	+OUT
2	+IN	23	+OUT
3	-IN	22	+OUT
4	-IN	21	-OUT
5	UV_OUT	20	-OUT
6	OV	19	-OUT
7	CLS	18	+OUT
8	TM	17	+OUT
9	VC	16	+OUT
10	RAL	15	-OUT
11	UV	14	-OUT
12	PC	13	-OUT

Table 2: PIN Numbers and Names for 613XXX iPOLs

Pin No.	Signal	Pin No.	Signal
1	+OUT	40	+OUT
2	-OUTA	39	-OUTB
3	+OUT	38	+OUT
4	-OUTA	37	-OUTB
5	+OUT	36	+OUT
6	-OUTA	35	-OUTB
7	+OUT	34	+OUT
8	-OUTA	33	-OUTB
9	+OUT	32	+OUT
10	-OUTA	32	-OUTB
11	+OUT	30	+OUT
12	-OUTA	29	-OUTB
13	+IN	28	-IN
14	+IN	27	-IN
15	+IN	26	-IN
16	+IN	25	-IN
17	VC	24	UV_OUT
18	RAL	23	OV
19	UV	22	CLS
20	PC	21	TM

**Note:**

1) The Negative output leads (-OUTA, -OUTB) must be connected TOGETHER on the board as close to the iPOL as possible

## SCDIPOL

Isolated POL (iPOL) Series

## DC-DC Converters

Table 3: Pin Functional Descriptions

Pin	Description	Function
+IN / -IN	Input voltage pins	Apply input voltage with all +IN pins in parallel and all -IN in parallel. -IN is also the reference (GND) for all control signals.
+OUT	Positive output voltage pins	Draw output power from any or all +OUT pins in parallel. Note that output is isolated from input. Loads should be connected between a +OUT pin and its adjacent -OUT pin to minimize noise and Rout.
-OUT	Negative output voltage pins	Draw output power from any or all -OUT pins in parallel.
CLS (IM)	Current-Limit-Slow and Current Monitor pin	Connect a resistor to -IN (GND) to set the slow current limit threshold. A parallel capacitor sets the time constant for the slow current limit trip. The voltage on this pin may be monitored as an analog of the load current.
OV	Overvoltage pin	When the voltage on this pin exceeds 1.20V the module will shut down. Connect to a voltage divider between +IN and -IN (GND).
PC	Primary Control pin	When open the module is on. When pulled below 1V the module will shut down.
RAL	Internal thermistor	Connect to IRM to add adaptive temperature compensation.
TM	Temperature Monitor	This output provides the internal controller temperature at 10mV / °C, +/- 20°C.
UV	Under-voltage pin	When the voltage on this pin falls below 1.20V the module will shut down. Connect to a voltage divider between +IN and -IN (GND).
UV_OUT	Under-voltage hysteresis output pin	This pin is at 3V when operating and falls to 0V when in under-voltage shutdown.
VC	IRM control pin	Startup control voltage sourced by IRM module when in VC startup mode.

# SCDIPOL

Isolated POL (iPOL) Series

## DC-DC Converters

### Package Pinout Diagram

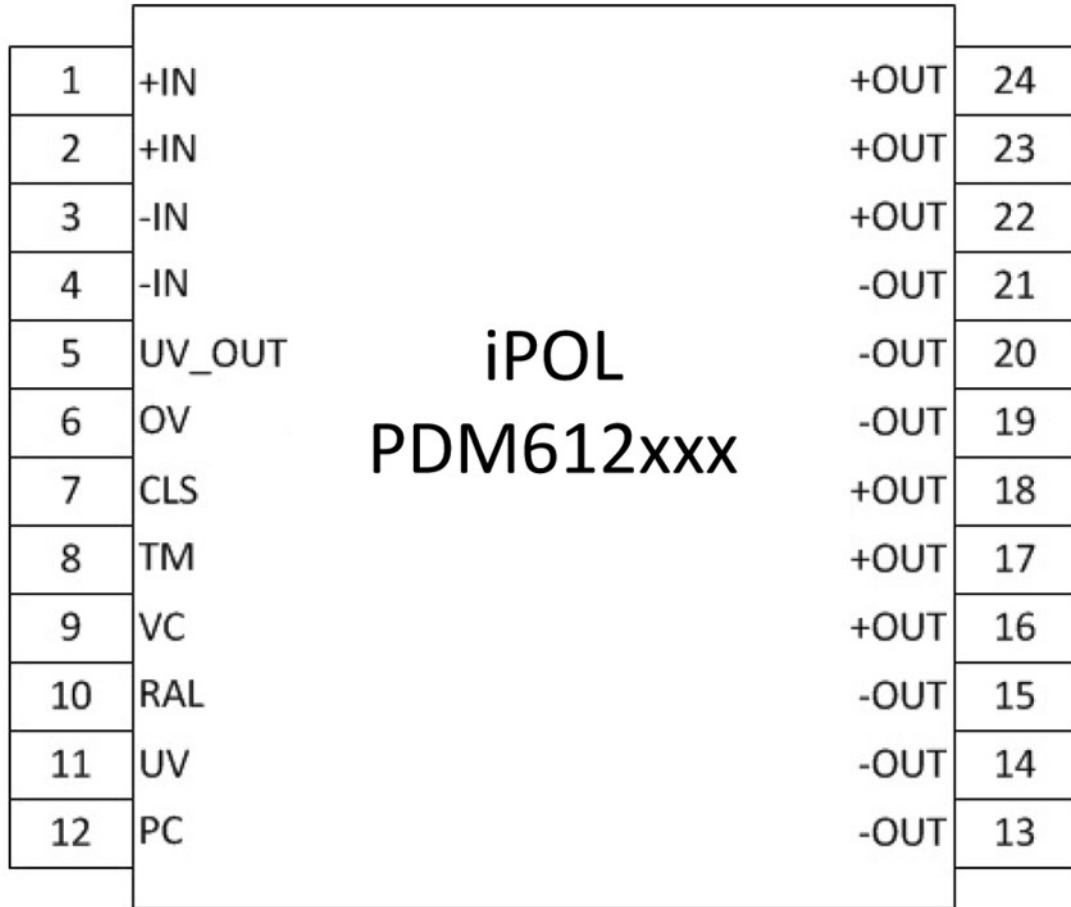

Figure 3: Package Pinout Diagram for 612xxx iPOLs

# SCDIPOL

Isolated POL (iPOL) Series

## DC-DC Converters

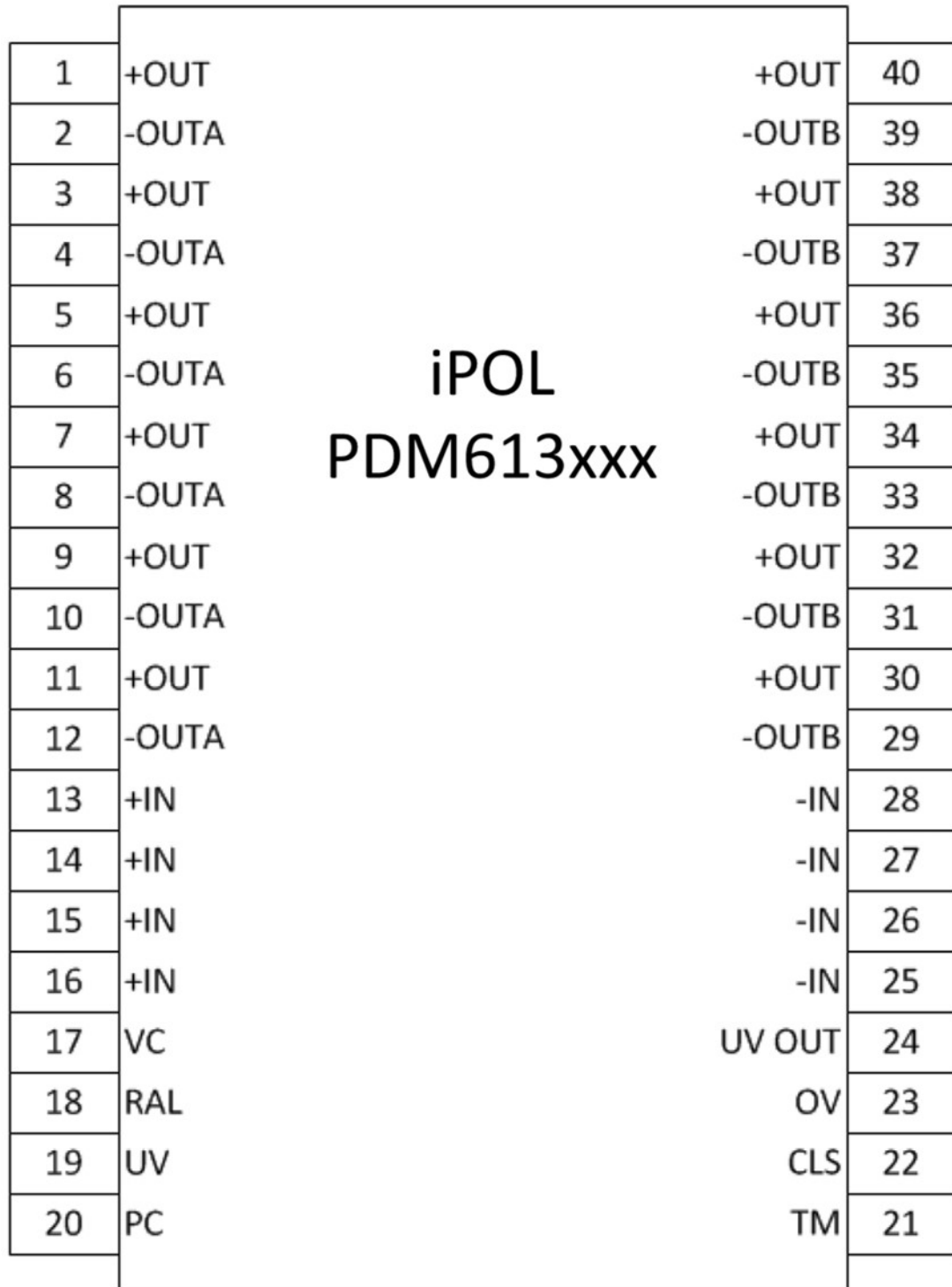

Figure 4: Package Pinout Diagram 613xxx iPOLs

## SCDIPOL

Isolated POL (iPOL) Series

## DC-DC Converters

## Functional Description

## Control Functions

There are three ways for an iPOL to be turned on; PC Mode, VC mode and Self Start mode.

## VC Mode

In VC Mode the iPOL is started by the IRM. This mode is used when the IRM ramps its output slowly from 0V to control inrush currents. The VC pin of the iPOL is connected to the VC pin of the IRM. The IRM provides nominal 8V startup power to the iPOL for 10mS until the iPOL input voltage has risen high enough for the iPOL to generate its own control voltage (approximately  $22V_{IN}$ ). The 612xxx iPOLs should not be used in this mode as this mode disables their internal soft start.

## PC Mode

In PC Mode the iPOL is controlled by its PC pin. The iPOL will start whenever the input voltage is above approximately 22V and the PC pin is open. When the PC pin is pulled to GND (-IN) the module will be off. The VC pin is not used and should be left unconnected. The 613xxx iPOLs should not be used in this mode as they depend on the IRM output rise time for inrush current limiting.

## Self-Start Mode

In Self-start Mode the iPOL will start whenever the input voltage is above approximately 22V and the PC pin and the VC pin are floating. In this case, the 612xxx iPOLs will soft start up until the output voltage reaches the input voltage times its K factor. At that point, the output will rise as a function of the rise time of the input voltage. The 613xxx iPOLs should not be used in this mode because they depend on the IRM output rise time for soft start.

## Over-Voltage Detection

The OV pin is used for overvoltage shutdown protection. The pin threshold is 1.20V. An external resistor voltage divider is used to set the input overvoltage level. For example, if a 1.21k ohm resistor is connected from the OV pin to -IN and a 49.9k resistor is connected from +IN to the OV pin, the overvoltage trip point will be 50.7V.

OV Threshold Equation:

$$\left[ \frac{49.9k+1.21k}{1.21k} \right] * 1.20V = \text{OV threshold}$$

## Under-Voltage Detection

The module UV pin is used for under-voltage shutdown protection. The pin threshold is 1.20V. An external resistor voltage divider is used to set the input under-voltage level. For example, if a 1.21k ohm resistor is connected from the UV pin to -IN and a 22.6k resistor is connected from +IN to the UV pin, the under-voltage trip point will be 23.6V.

UV Threshold Equation:

$$\left[ \frac{22.6k+1.21k}{1.21k} \right] * 1.20V = \text{UV threshold}$$

## SCDIPOL

Isolated POL (iPOL) Series

## DC-DC Converters

When an under-voltage is detected, the module will shut-down and then restart when the input is back in range. The UV\_OUT pin may be used to provide additional hysteresis. When the module is ON, the UV\_OUT pin is 3V. When an under-voltage is detected, the UV\_OUT pin falls to 0V. Hysteresis may be added by connecting a resistor from the UV\_OUT pin to the UV pin. A 100k resistor will add about 0.5V hysteresis.

**Current Limit Slow**

The CLS function protects the iPOL from overload currents (prevents thermal overstress of the components within the iPOL). The CLS (IM) pin source current varies in proportion to the output current. Connect a 10Kohm resistor from the CLS (IM) pin to -IN to scale the voltage. The current limit trip point is nominally 1.2V, so the 10k ohms resistor will set the trip point approximately 133% of full output. A capacitor needs to be placed across the resistor to integrate the source current and delay the trip. A capacitor of 0.27 $\mu$ F will give a time constant of 2.7mS resulting in a trip time of 8mS for an overload of 140%. Reduce this resistor to 1Kohms to rely on the internal current limit of the iPOL (and disable the CLS current limit function), which protects the iPOL from short circuit output.

**Absolute Maximum Ratings** <sup>(1, 2)</sup>**Table 4: Absolute Maximum Ratings**

Symbol	Parameter	MIN	MAX	Units
V <sub>IN</sub>	Positive Supply Voltage	-0.3	+55.0	V <sub>DC</sub>
OV, UV, PC pins	Max Voltage on PC, OV and UV Pins	-0.3	+4.0	V <sub>DC</sub>
VC	Max Voltage on VC Pin	-0.3	11	V <sub>DC</sub>
	Input to Output Isolation <sup>(4)</sup>	--	200	V <sub>DC</sub>
T <sub>J</sub> <sup>(3)</sup>	Operating Temperature Range	-40	+125	°C
T <sub>STG</sub>	Storage Temperature	-55	+125	°C

**Notes:**

- 1) Stresses outside the listed absolute maximum ratings may cause permanent damage to the device. This is a stress rating only and functional operation of the device at these or any other conditions beyond limits indicated in the operational sections of this specification are not recommended. Exposure to absolute maximum rating conditions for extended periods may affect device reliability and performance.
- 2) All voltages referenced to -IN
- 3) Junction Temperature. Corresponds to a 105C lead temperature at maximum load or no load condition at 115C lead temperature.
- 4) All input pins tied together to all output pins tied together

## SCDIPOL

Isolated POL (iPOL) Series

## DC-DC Converters

Operational Environment <sup>(1)</sup>

Table 5: Operational Environment

Symbol	Parameter	Limit	Units
TID	Total Ionizing Dose <sup>(2)</sup>	100	krad(Si)
SEL	Single Event Latchup Immunity <sup>(3)</sup>	>80	MeV-cm <sup>2</sup> /mg

## Notes:

- 1) For devices with procured with a total ionizing dose tolerance guarantee, post-irradiation performance is guaranteed at 25°C per MIL-STD-883 Method 1019, Condition A up to maximum TID level procured.
- 2) Per MIL-STD-883, method 1019, condition A (*Optional: Per MIL-STD-883, method 1019.9, condition A, with extended room temperature anneal per section 3.11.2*)
- 3) SEL is performed at 125°C

Recommended Operating Conditions <sup>(1)</sup>

Table 6: Recommended Operating Conditions

Symbol	Parameter	MIN	MAX	Units
T <sub>L</sub> <sup>(2)</sup>	Case Operating Temperature Range	-40	+85	°C
V <sub>IN</sub>	Positive Supply Voltage	+26	+48	V <sub>DC</sub>

## Notes:

- 1) All voltages referenced to –IN
- 2) Lead Temperature of module.

## SCDIPOL

Isolated POL (iPOL) Series

## DC-DC Converters

**Electrical Characteristics** <sup>(1)</sup>(26V < V<sub>IN</sub> < 48V, -40°C < T<sub>J</sub> < +125°C); Unless otherwise noted.**Table 7: DC Electrical Characteristics**

Symbol	Parameter	Conditions	MIN	TYP	MAX	Units
<b>Input/Output Parameters</b>						
V <sub>IN</sub>	Input Supply Voltage		26	-	55	V <sub>DC</sub>
V <sub>OVT</sub>	Over-Voltage Trip Point	V <sub>IN</sub> Rising	1.15	1.23	1.28	V <sub>DC</sub>
	OV Hysteresis		0.030	0.060	0.090	V <sub>DC</sub>
	OV Response Time				4.7	μSec
V <sub>UVT</sub>	Under-Voltage Trip Point	V <sub>IN</sub> Falling	1.05	1.195	1.25	V <sub>DC</sub>
	UV Hysteresis		0.030	0.060	0.090	V <sub>DC</sub>
V <sub>UV HYST</sub>	Under-Voltage External Hysteresis Voltage	UV Untripped	3.0	3.3	3.6	V <sub>DC</sub>
		UV Tripped	0	-	0.2	V <sub>DC</sub>
PC <sup>(2)</sup>	PC Voltage	Enabled (floating PC Pin)	-	-	4.0	V <sub>DC</sub>
	PC threshold		1.0	-	1.2	V <sub>DC</sub>
	PC Source Current	iPOL Disabled	-	-	590	μA
	Enable Response Time		-	-	440	μSec
	Output Voltage Rise Time	(612xxx Modules Only)	400	-	1000	μSec
VC <sup>(2)</sup>	VC Input Voltage		-	10	-	V <sub>DC</sub>
	VC Pulse width		-	10	-	mSec
	VC Load Current		-	-	200	mA
	VC to Vout turn-on delay		-	-	400	μSec
CLS	CLS Threshold Voltage		0.89	1.2	1.3	V <sub>DC</sub>
	CLS (IM) Source Current	Maximum Continuous Load	5	90	125	μA
RAL	Thermistor to -IN	25C	-	10K		ohms
TM	Temperature Monitor	27C	-	2.0	-	V
	Gain		-	10	-	10mV / °C

**Notes:**

- 1) All voltages referenced to -IN
- 2) PC and VC parameters are guaranteed by design and not test.

# SCDIPOL

Isolated POL (iPOL) Series

## DC-DC Converters

**Table 8 Electrical Characteristics Continued;  
Rout of Each iPOL type in milliohms.**

iPOL PN	MIN	25°C Nom	MAX	MIN	85°C Nom	MAX	MIN	-40°C Nom	MAX
613140	0.8	1.0	1.2	1.0	1.2	1.4	0.7	0.9	1.2
613132 <sup>(2)</sup>	1.0	1.3	1.5	1.1.0	1.45	1.65	0.9	1.2	1.4
613124 <sup>(2)</sup>	1.4	1.6	1.7	1.52	1.79	1.85	1.2	1.5	1.7
612116	5.0	6.4	7.0	6.0	6.4	8.5	5.0	6.0	7.0
612112	6.6	7.7	10.0	6.6	7.4	10.7	6.5	7.0	10.0
612108	14.0	21.0	23.0	16.0	21.0	26.0	14.0	19.0	23.0
612106 <sup>(2)</sup>	21.0	30.0	32.0	24.0	33.0	36.0	24.0	28.0	33.0
612105 <sup>(2)</sup>	31.0	37.0	43.0	35.0	44.0	49.0	30.0	35.0	42.5
612104 <sup>(1)</sup>	37.0	44.0	51.0	44.0	52.0	59.0	33.0	42.0	50.0
612103 <sup>(1)</sup>	60.0	71.0	98.0	63.0	75.0	94.0	55.0	69	99
612102 <sup>(1)</sup>	75.0	80.0	85.0	85.0	90.0	95.0	70	75	80
612101 <sup>(1)</sup>	84.0	96.0	102.0	102.0	108.0	114.0	80	90	96

**Notes:**

- 1) Module not yet in production. Parameters are TBR.
- 2) Contact manufacturer for parameter verification.

**Table 9: Electrical Characteristic Continued; Output Characteristics**

iPOL	K Factor (V <sub>out</sub> /V <sub>in</sub> )	Max Output Current Continuous(A) <sup>(4)</sup>	Max Load Capacitance 48Vin(uF) <sup>(2)</sup>	Output Ripple Frequency Minimum MHz <sup>(3)</sup>	Output Ripple Frequency Maximum MHz <sup>(3)</sup>	Max Output Voltage Ripple mVp^p
613140	1/40	50	5,000	2.51	3.26	340
613132	1/32	50	5,000	2.88	3.52	330
613124 <sup>(1)</sup>	1/24	37.5	3500	2.88	3.52	220
612116	1/16	16.7	3500	2.88	3.52	250
612112	1/12	12.5	2000	2.40	3.19	250
612108	1/8	8.33	700	2.40	3.19	250
612106	1/6	6.25	400	2.40	3.19	200
612105	1/5	5.2	300	2.40	3.19	260
612104 <sup>(1)</sup>	1/4	4.17	200	2.40	3.19	220
612103 <sup>(1)</sup>	1/3	3.125	100	2.40	3.19	480
612102 <sup>(1)</sup>	1/2	2.1	50	2.40	3.19	175
612101 <sup>(1)</sup>	1/1	1.04	10	2.40	3.19	250

**Notes:**

- 1) Module not yet in production. Parameters are TBR.
- 2) Values are calculated, not tested. Values indicate ability to start-up module during recommended start-up mode with a CLS resistance of 10Kohms.
- 3) Values are calculated for EOL and not tested.
- 4) Maximum current at which all internal components meet deratings with an 85°C lead temperature and a 48V input.

# SCDIPOL

Isolated POL (iPOL) Series

## DC-DC Converters

**Table 10 Electrical Characteristic Continued;**

**Maximum no load power dissipation (W) vs. input voltage and temperature <sup>(4)</sup> and efficiency <sup>(2)</sup>**

iPOL	No Load Vin=2 6V 25C to 85C	No Load Vin=3 2V 25C to 85C	No Load Vin=4 8V 25C to 85C	No Load Vin=26 V-40C	No Load Vin=32 V-40C	No Load Vin=48V -40C	No Load Vin=26 V >85C to 125C	No Load Vin=32 V >85C to 125C	No Load Vin=48 V >85C to 125C	Min Efficien cy Max Load	Min Efficien cy 1/3 Load
613140	3.4	3.7	5.3	4.6	5.0	7.1	4.1	4.4	6.4	88.5%	82.5%
613132	3.3	3.9	5.4	5.5 <sup>(3)</sup>	6.4 <sup>(3)</sup>	8.5 <sup>(3)</sup>	4.1	4.4	6.4	89.4%	84.2%
613124 <sup>(1)</sup>	3.0	3.3	5.0	4.0	4.5	7.5	3.4	4.0	6.4	89.4%	87.1%
612116	2.0	2.1	2.8	2.5	2.7	4.2	2.4	2.5	3.4	91.5%	87.3%
612112	2.1	2.3	3.4	2.5 <sup>(3)</sup>	2.8 <sup>(3)</sup>	4.1 <sup>(3)</sup>	2.5	2.8	4.1	90.5%	86.6%
612108	2.5	2.5	2.9	3.5	3.5	4.1	3.0	3.0	3.5	91.5%	85.6%
612106	2.1	2.4	3.3	2.5 <sup>(3)</sup>	2.8 <sup>(3)</sup>	3.8 <sup>(3)</sup>	TBS	TBS	TBS	92.5%	90.5%
612105	2.2	2.5	3.5	2.6 <sup>(3)</sup>	2.9 <sup>(3)</sup>	4.0 <sup>(3)</sup>	TBS	TBS	TBS	89.8%	85.0%
612104 <sup>(1)</sup>	1.4	1.9	2.9	2.9	2.9	3.4	TBS	TBS	TBS	92.5%	88.5%
612103 <sup>(1)</sup>	1.5	1.9	2.5	2.9	2.9	3.4	TBS	TBS	TBS	94.9%	89.2%
612102 <sup>(1)</sup>	2.5	2.5	2.9	2.9	2.9	3.4	TBS	TBS	TBS	91.0%	85.6%
612101 <sup>(1)</sup>	2.4	2.3	3.4	2.9	2.9	3.4	TBS	TBS	TBS	90.5%	85.0%

**Notes:**

- 1) Module not yet in production. Parameters are TBR.
- 2) Efficiency guaranteed from 25°C to 85°C lead temperature.
- 3) Contact manufacturer for verification of values.
- 4) Temperatures reflect module lead temperature.

# SCDIPOL

Isolated POL (iPOL) Series

# DC-DC Converters

## Package Drawings

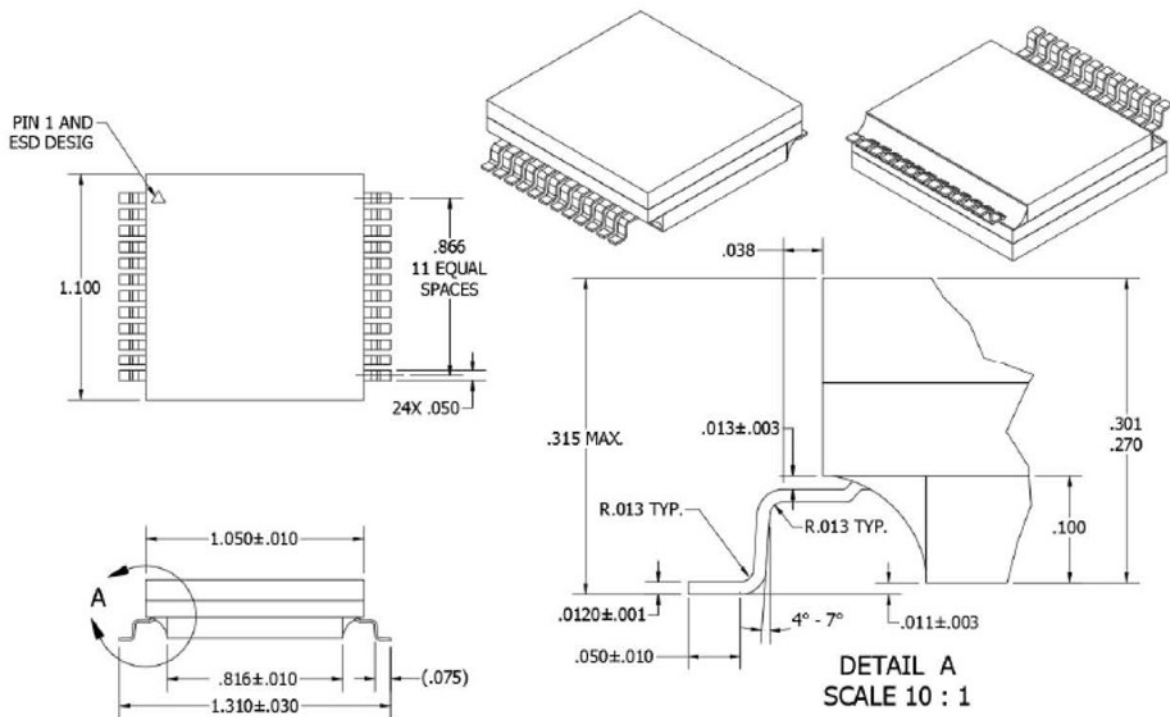

Dimensions in inches.

Tolerances ±.005 inches unless otherwise noted.

Figure 5: Package Drawing for 612xxx Modules

## Lead Material and Plating

Lead material is Copper, UNS No. C10100 IAW ASTM-B152/B512M. Temper is H02-Half Hard. Plating is Gold Plated, 5-10 micro-inches IAW MIL-DTL-45204, Type I, Grade A, Class 1, over Electrolytic Nickel plated 200-350 micro-inches in accordance with AMS-QQ-P290, Class 1, Grade G. Final finish is Sn60/Pb40.

**Table 11: Mechanical Characteristics**

SYM	Parameter	Conditions	MIN	TYP	MAX	Unit
L	Length	-	-	-	1.105 [28.067]	in [mm]
W	Width	-	-	-	1.06 [26.924]	in [mm]
H	Height	-	-	-	0.315 [8.001]	in [mm]
Wt	Weight	-	-	-	16	g
-	Soldering tip dwell time per single pin	Tip temperature 600°F Assembly pre-heated to 125°F	-	-	6	Sec

**Note:** Product is not designed for reflow applications. Manual soldering of leads is required.

## SCDIPOL

Isolated POL (iPOL) Series

## DC-DC Converters

Conversion	
INCH	MM
0.001	0.025
0.003	0.076
0.005	0.127
0.010	0.254
0.011	0.279
0.012	0.305
0.013	0.330
0.030	0.762
0.038	0.965
0.050	1.270
0.075	1.905
0.100	2.540
0.270	6.858
0.301	7.645
0.315	8.001
0.816	20.726
0.866	21.996
1.050	26.670
1.100	27.940
1.310	33.274

# SCDIPOL

Isolated POL (iPOL) Series

## DC-DC Converters

### Package Drawings

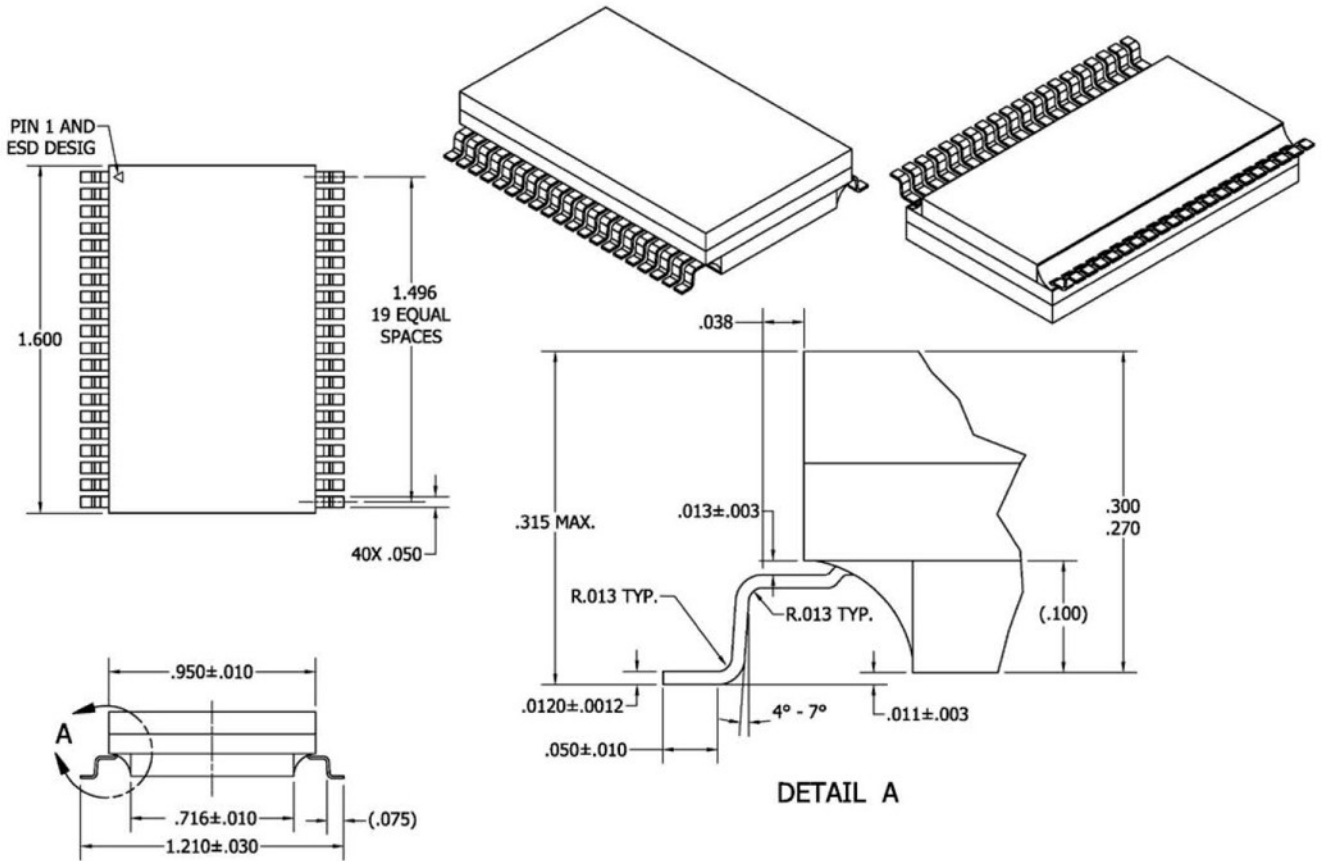

Dimensions in inches.  
 Tolerances ±.005 inches unless otherwise noted.  
 Figure 6: Package Drawing for 613xxx Modules

### Lead Material and Plating

Lead material is Copper, UNS No. C10100 IAW ASTM-B152/B512M. Temper is H02-Half Hard. Plating is Gold Plated, 5-10 micro-inches IAW MIL-DTL-45204, Type I, Grade A, Class 1, over Electrolytic Nickel plated 200-350 micro-inches in accordance with AMS-QQ-P290, Class 1, Grade G. Final finish is Sn60/Pb40.

**Table 12: Mechanical Characteristics**

SYM	Parameter	Conditions	MIN	TYP	MAX	Unit
L	Length	-	-	-	1.605 [40.767]	in [mm]
W	Width	-	-	-	0.960 [24.384]	in [mm]
H	Height	-	-	-	0.315 [8.001]	in [mm]
Wt	Weight	-	-	-	25	g
-	Soldering tip dwell time per single pin	Tip temperature 600°F Assembly pre-heated to 125°F	-	-	6	Sec

**Note:** Product is not designed for reflow applications. Manual soldering of leads is required

## SCDIPOL

Isolated POL (iPOL) Series

## DC-DC Converters

Conversion	
INCH	MM
0.001	0.025
0.003	0.076
0.005	0.127
0.010	0.254
0.011	0.279
0.012	0.305
0.013	0.330
0.030	0.762
0.038	0.965
0.050	1.270
0.075	1.905
0.100	2.540
0.270	6.858
0.315	8.001
0.716	18.186
0.866	21.996
0.950	24.130
1.050	26.670
1.100	27.940
1.210	30.734
1.310	33.274
1.600	40.640

# SCDIPOL

Isolated POL (iPOL) Series

## DC-DC Converters

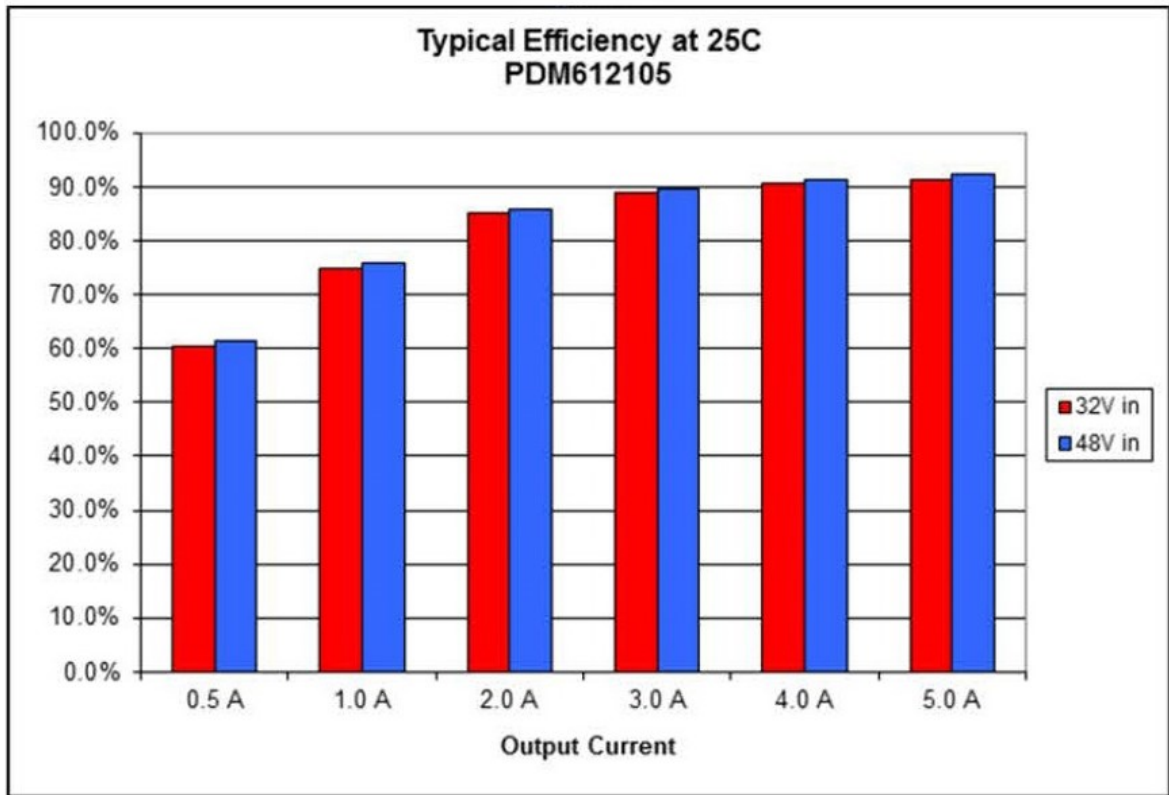

Figure 7

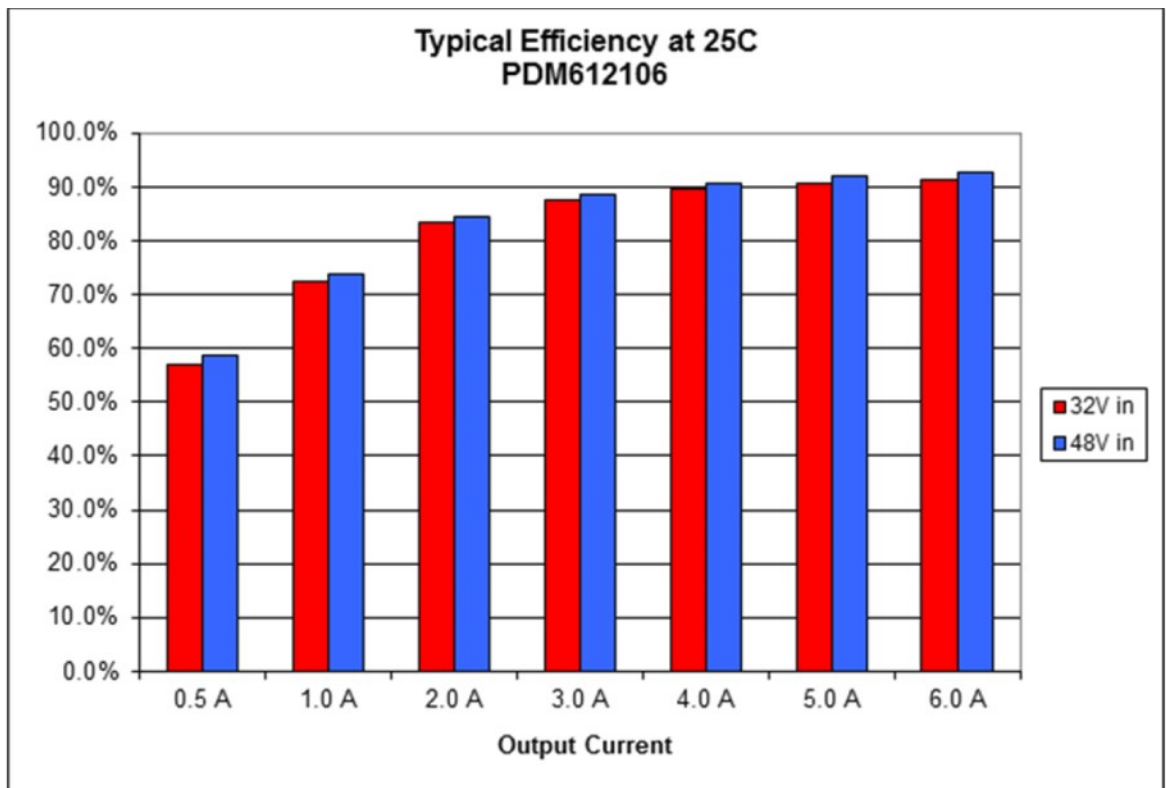

Figure 8

# SCDIPOL

Isolated POL (iPOL) Series

## DC-DC Converters

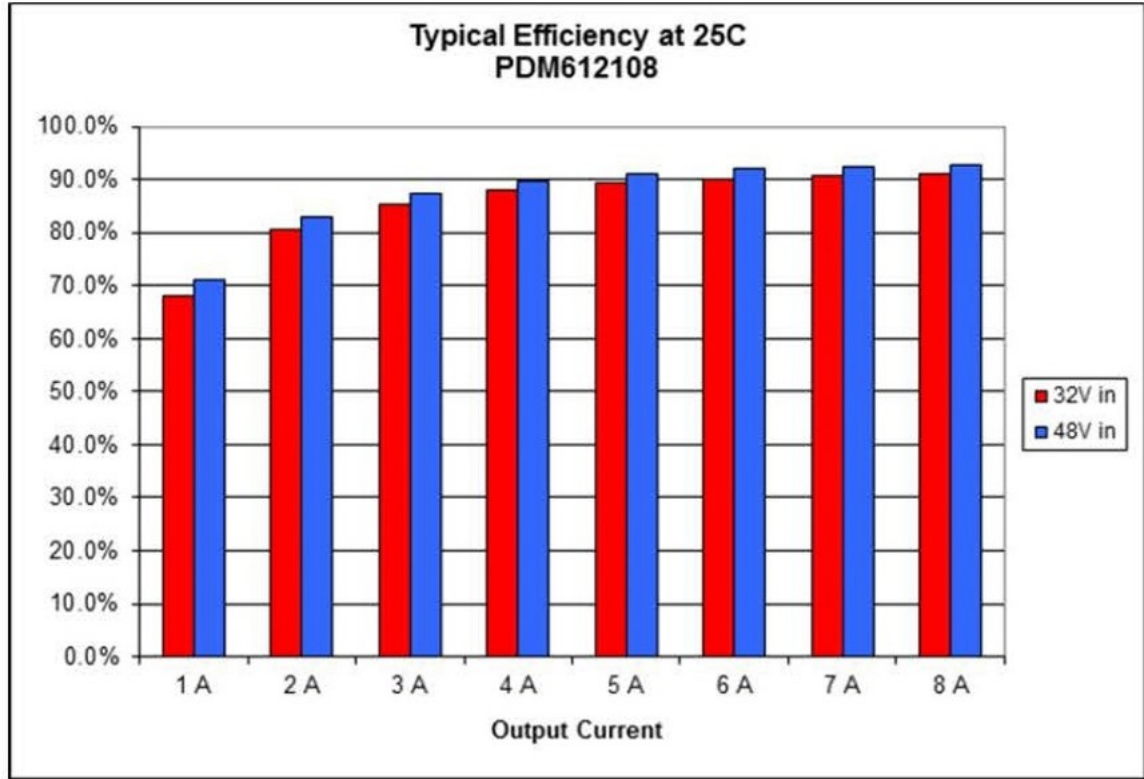

Figure 9

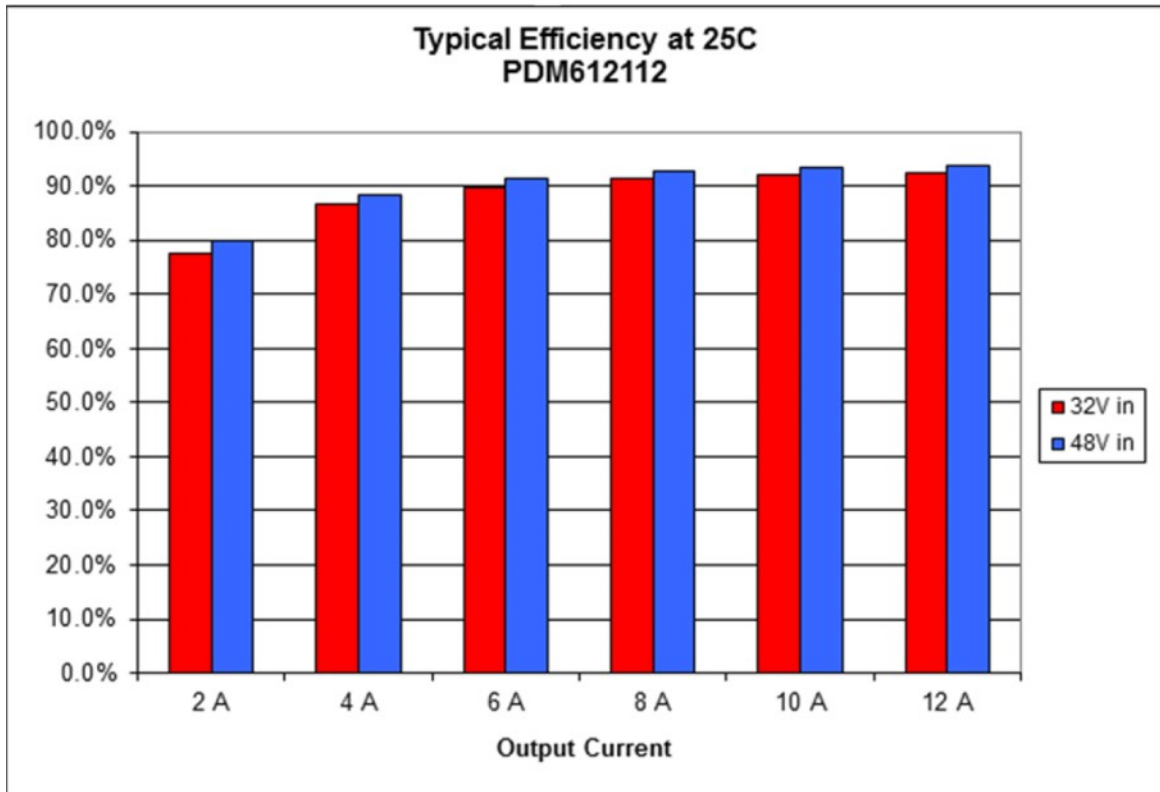

Figure 10

# SCDIPOL

Isolated POL (iPOL) Series

## DC-DC Converters

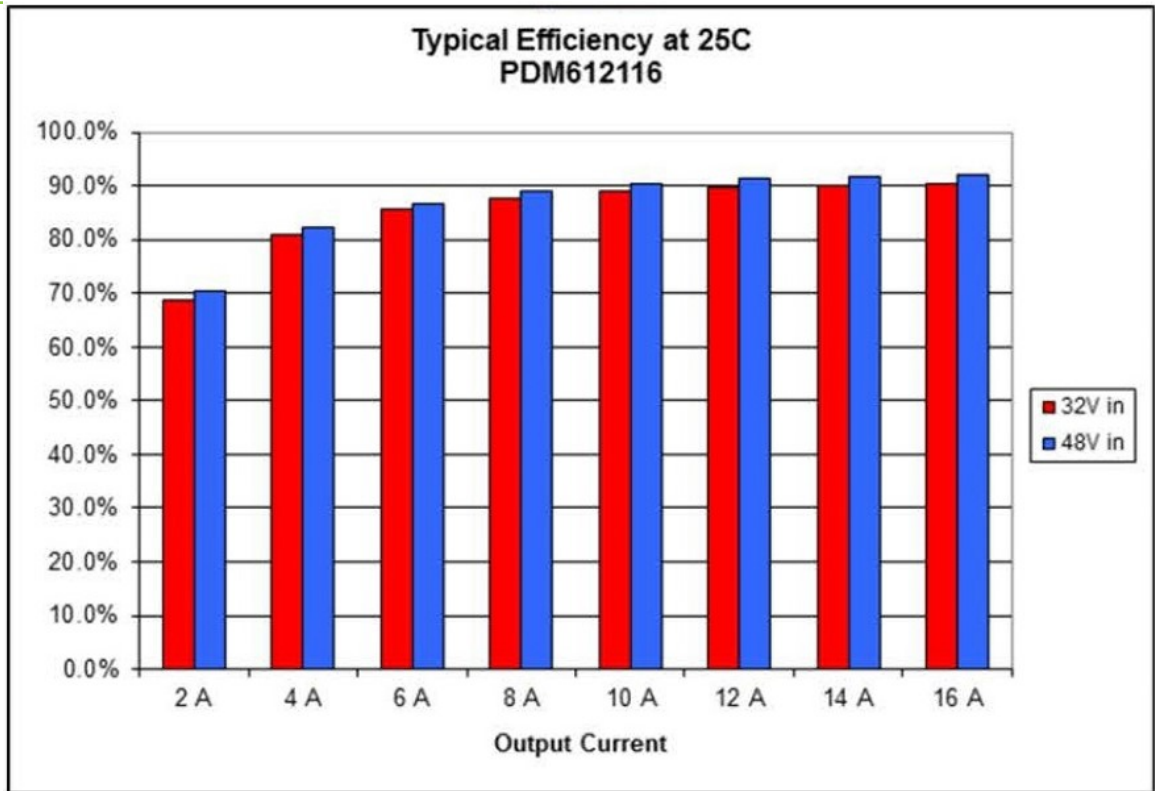

Figure 11

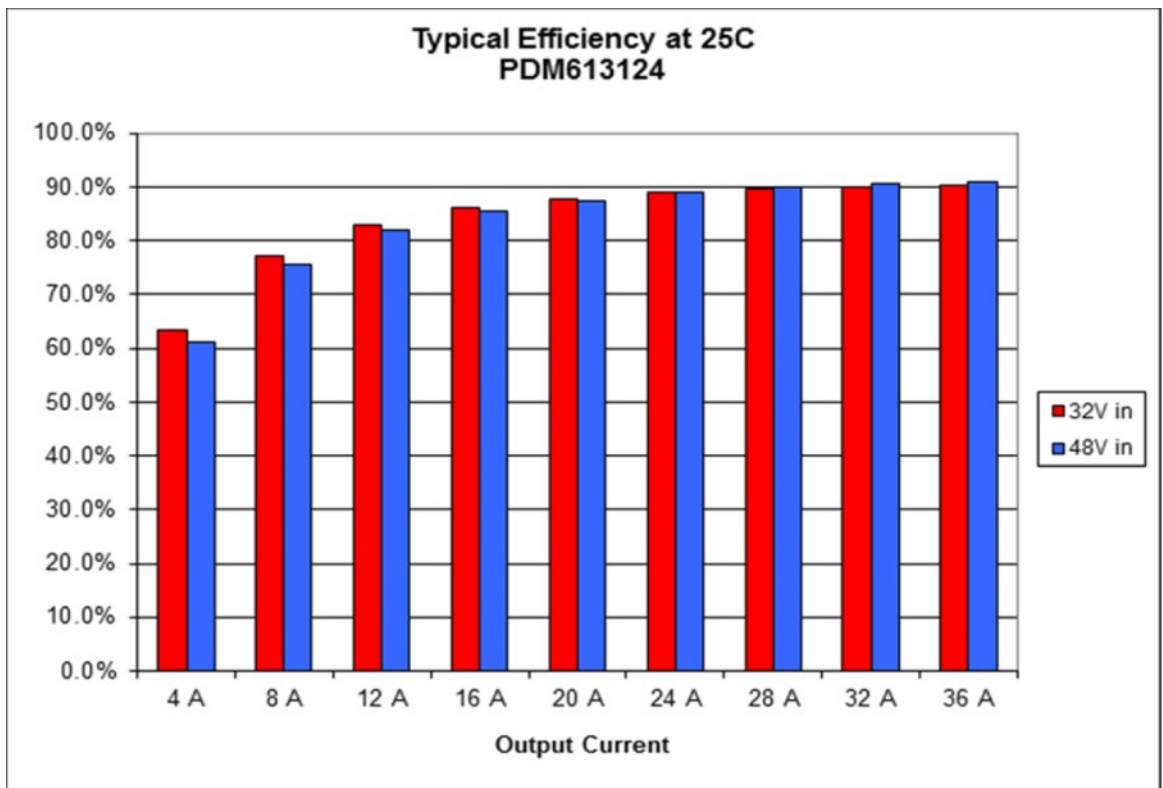

Figure 12

# SCDIPOL

Isolated POL (iPOL) Series

## DC-DC Converters

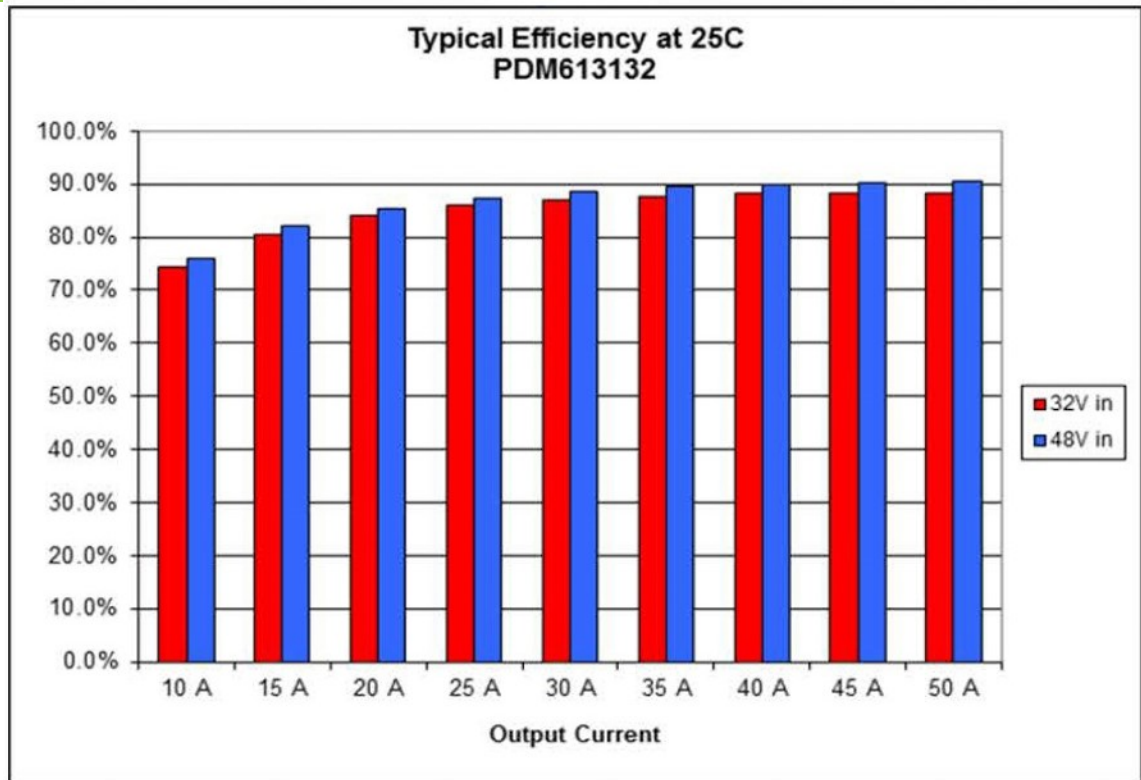

Figure 13

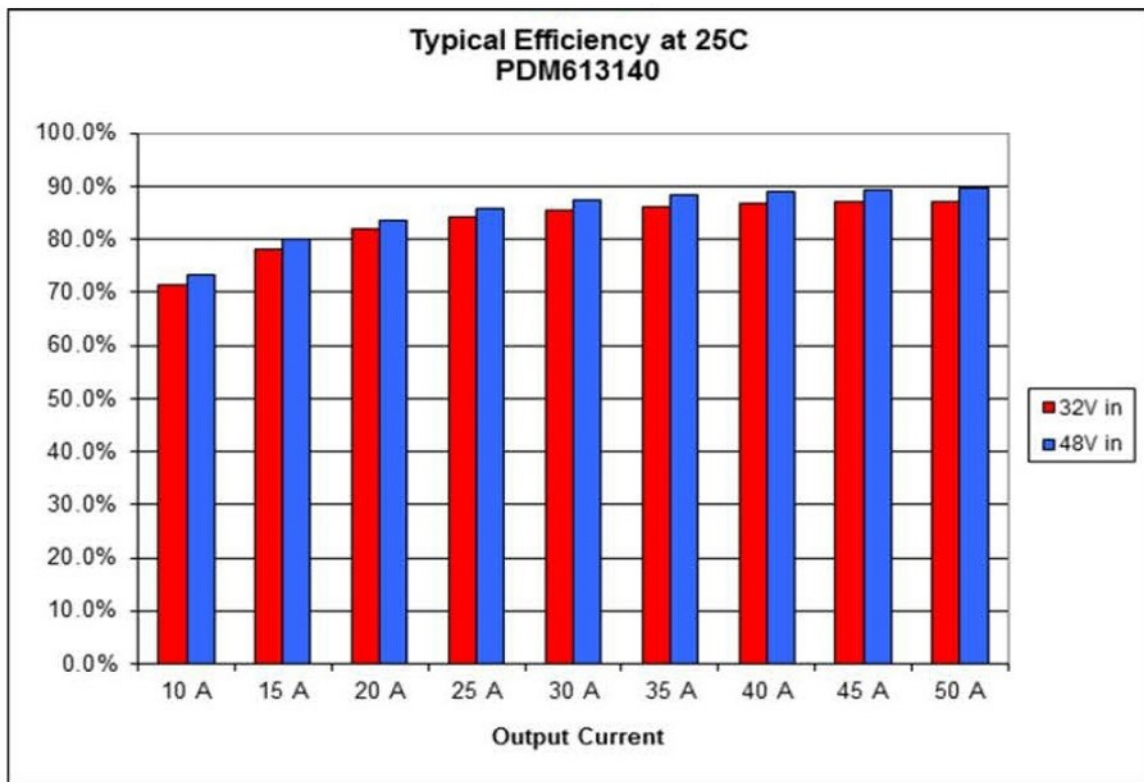

Figure 14

# SCDIPOL

Isolated POL (iPOL) Series

# DC-DC Converters

## Ordering Information

### Generic Datasheet Part Numbering

PDM61xxxx - \*

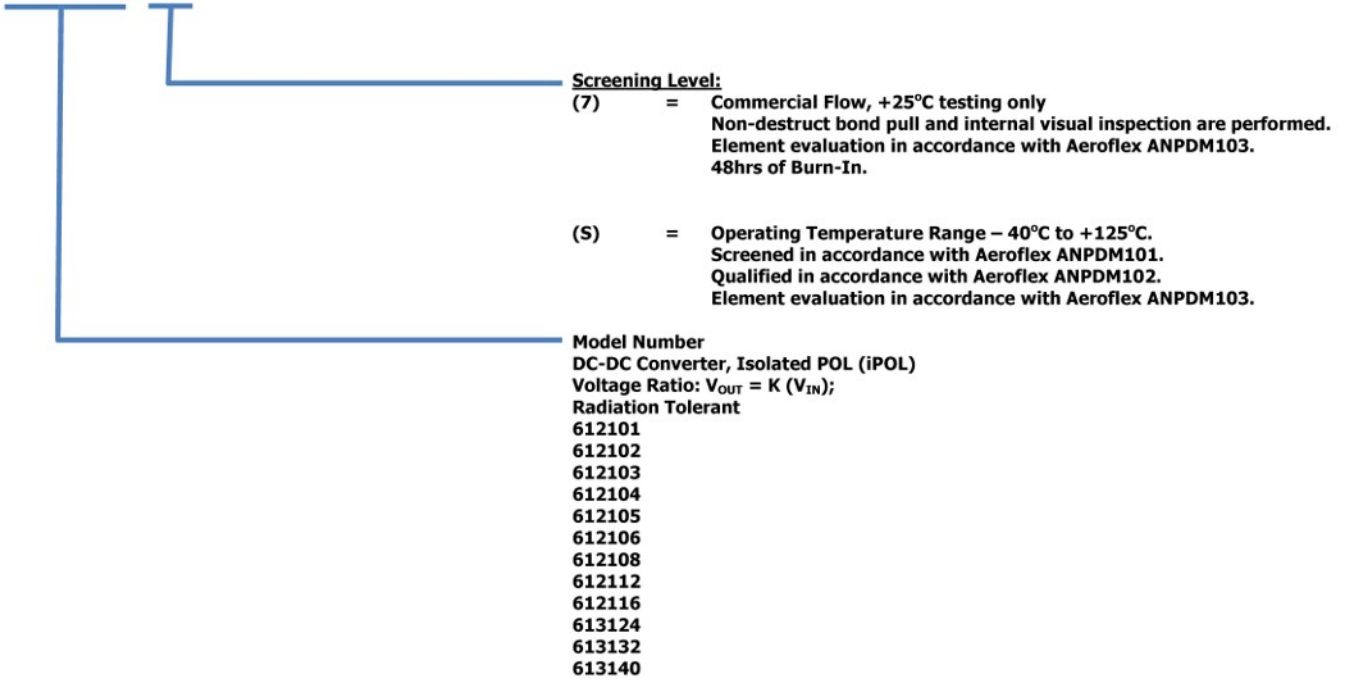

## Revision History

Date	Revision	Change Description	Initials
03/13/17	A	Initial Release	CL
03/08/21	B	Revised Per ECN 23542	

## SCDIPOL

Isolated POL (iPOL) Series

## DC-DC Converters

## Datasheet Definitions

	DEFINITION
Advanced Datasheet	CAES reserves the right to make changes to any products and services described herein at any time without notice. The product is still in the development stage and the datasheet <b>is subject to change</b> . Specifications can be <b>TBD</b> and the part package and pinout are <b>not final</b> .
Preliminary Datasheet	CAES reserves the right to make changes to any products and services described herein at any time without notice. The product is in the characterization stage and prototypes are available.
Datasheet	Product is in production and any changes to the product and services described herein will follow a formal customer notification process for form, fit or function changes.

The following United States (U.S.) Department of Commerce statement shall be applicable if these commodities, technology, or software are exported from the U.S.: These commodities, technology, or software were exported from the United States in accordance with the Export Administration Regulations. Diversion contrary to U.S. law is prohibited.

Cobham Long Island Inc. d/b/a CAES reserves the right to make changes to any products and services described herein at any time without notice. Consult an authorized sales representative to verify that the information in this data sheet is current before using this product. The company does not assume any responsibility or liability arising out of the application or use of any product or service described herein, except as expressly agreed to in writing; nor does the purchase, lease, or use of a product or service convey a license under any patent rights, copyrights, trademark rights, or any other of the intellectual rights of the company or of third parties.