

HAMAMATSU *Photonics*

2006 Vol. 2 **S**

tech news

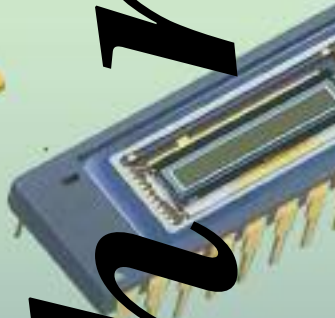
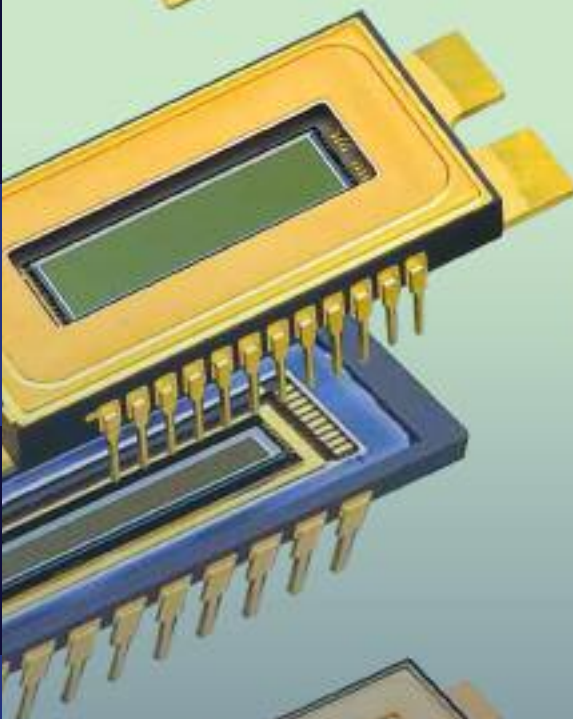
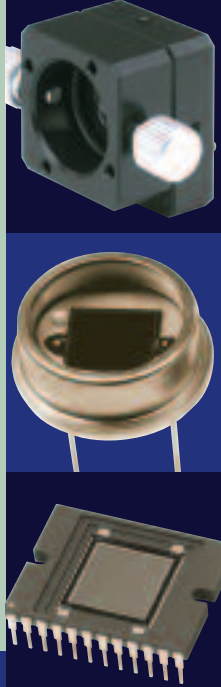

New CCD for Low-Light Scientific Applications

High-Speed InGaAs APD + TIA ROSA

Highly Sensitive Image Intensifier with Large Active Area

Flat-Panel Sensor Product Line Extended

The Improved Macro Imaging System AEQUORIA

Imaging-Based Plate Reader FDSS for High-Throughput Screening

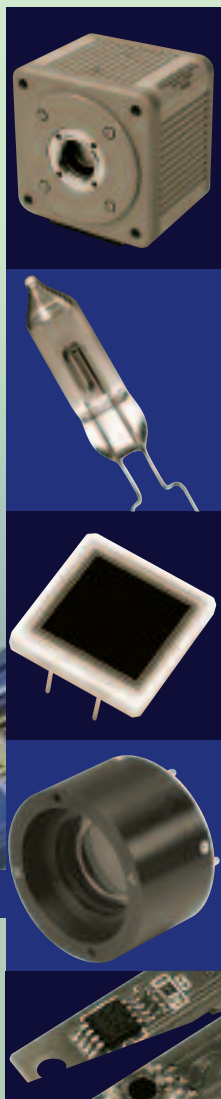

Contents

New MCP-PMT Series with
High Sensitivity

C
o
n
t
e
n
t
s

2nd Generation
InGaAs Camera
for Emission Microscopy

3 Solid State Products

11 Data Communication

Photo IC with Close-to-
Human-Eye Response and
CdS-Cell-Shaped Housing

16 Electron Tube Products

20 X-ray

FA-Navigation Software

FFT CCD for
Low-Light-Level Detection

23 Cameras

26 Aequoria System

27 FDSS

Silicon Photodiode for
Monitoring High-Power
Violet Laser Diodes

28 Company News

UVTRON R9454
Quick Detection of Flame

Compact Sealed
Micro-Focus X-Ray Source

CMOS Linear Image Sensor

FFT CCD for Low-Light-Level Detection

Full-frame transfer CCDs are image sensors, specially designed for low-light-level detection. They have the ideal characteristics, such as extremely low noise, an image signal with high S/N and a 100% fill-factor level, to allow the collection of low-light-level images.

The S9972/S9973 are new additions to the Hamamatsu FFT CCD family, featuring high infrared sensitivity and an effective pixel size of 24 μm x 24 μm . These image sensors can operate in line binning, offering significant improvement in S/N and signal-processing speed. They also feature pixel or horizontal binning to provide a higher contrast image.

Author: Federica Gornati
Hamamatsu Photonics Italy

Features:

- Pixel size: 24 μm x 24 μm
- Line/pixel binning
- MPP operation
- High IR sensitivity
- 100% fill factor

Applications:

- Low-light-level detection
- Fluorescence spectrometry, ICP
- Raman spectrometry

Spectral response (without window)

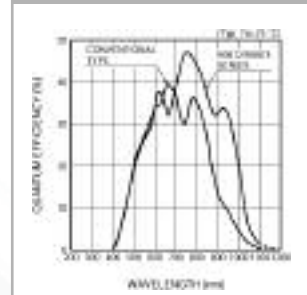

Spectral transmittance characteristics

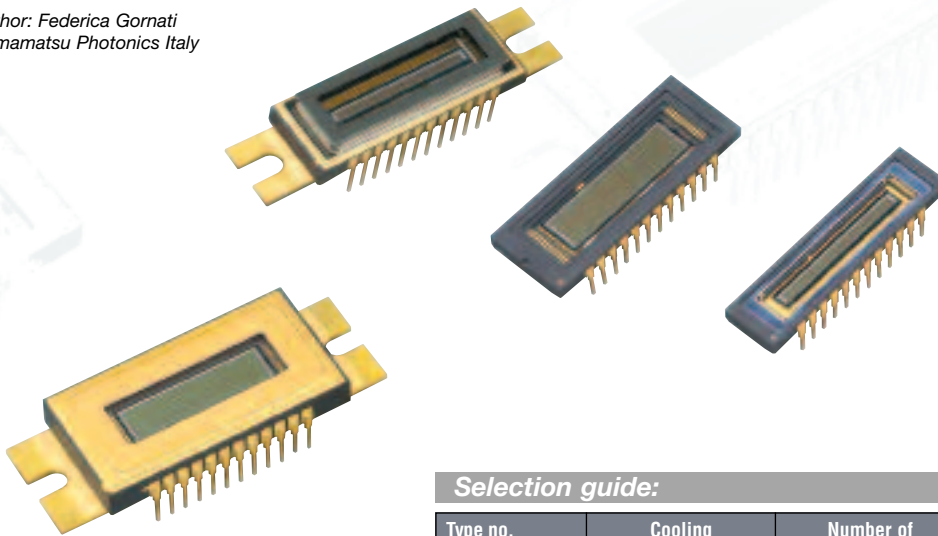
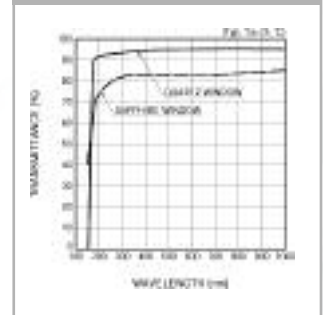

Selection guide:

Type no.	Cooling	Number of total pixels	Number of active pixels	Active area [mm (h) x mm (v)]
S9972-1007	Non-cooled	1044 x 128	1024 x 124	24.576 x 2.976
S9972-1008	Non-cooled	1044 x 256	1024 x 252	24.576 x 6.048
S9973-1007	One-stage	1044 x 128	1024 x 124	24.576 x 2.976
S9973-1008	TE-cooled	1044 x 256	1024 x 252	24.576 x 6.048

Exhibitions

Semicon West (Moscone Center, San Francisco, CA)
Jul 11-13, 2006

AACC (McCormick Place, Chicago, IL)
Jul 25-27, 2006

S9978

S9978 FFT CCD

Hamamatsu develops and manufactures front-illuminated CCD-area-image sensors used for imaging and measurement in the visible and near infrared range.

We now introduce the latest addition to our range of FFT-CCD, the S9978, featuring 512 pixel x 512 pixel, a wide spectral response range of 400 nm to 1100 nm and high infrared sensitivity.

The S9978 series utilizes MPP operation mode to achieve a typical dark current of 100 e⁻/pixel/s at 0° C; complementing the low-dark-current level is a typical readout noise of only 4 e⁻rms. The result is a very low-light-level detection capability and a long integration time, providing a wide dynamic range of typically 60,000.

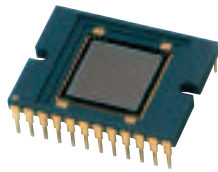

Dimensional outline

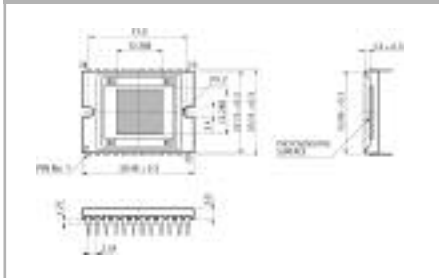

The technical characteristics of the S9978 are ideal for a wide range of scientific applications, such as fluorescence spectrometry, Raman spectrophotometry and astronomy.

Author: Federica Gornati
Hamamatsu Photonics Italy

Features:

- High IR sensitivity
- 100% fill factor
- MPP operation
- Low dark current

Applications:

- Astronomy
- Optical and spectrophotometric analysis
- Scientific measuring instruments
- Fluorescence spectrometry

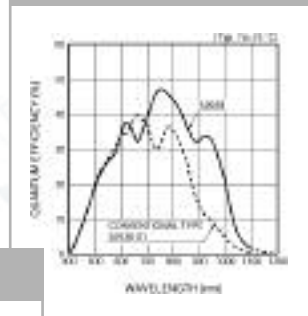
Spectral response
(without window)

S9970/S9971 series

Low Dark Signal / Low Readout Noise /

Introducing our new, high-performance, low-price FFT-CCD series S9970/S9971, developed using our new 6-inch wafer process and featuring low readout noise.

Front-illuminated CCDs are a reasonably priced alternative to back-illuminated CCDs, if the measured amount of light is not extremely low.

FFT (full-frame transfer) means that it contains no insensitive areas, as interline CCDs do.

Our FFT-CCDs can be used in "line binning mode" (the charges of vertical pixels are added and the detector works like a line sensor) or in "pixel binning mode" (the charges of neighboring cells are added).

The optimal readout method "multi-pinned phase mode" also provides a significant reduction of noise over long integration times and a wide dynamic range.

Author: Dieter Habben
Hamamatsu Photonics Germany

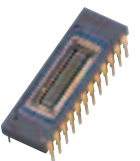
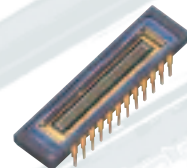
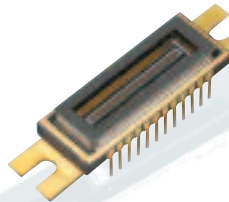
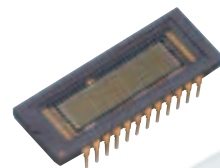
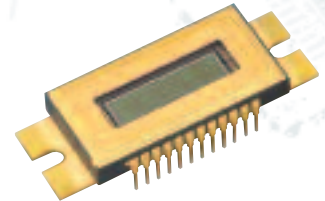

Microscopy & Microanalysis (Navy Pier, Chicago, IL)
Jul 30-Aug 3, 2006

HAMAMATSU
Photonics

Features:

- 512 (h) x 60 (v) to 1024 (h) x 252 (v) pixel format
- Pixel size: 24 μm x 24 μm
- Line/pixel binning
- 100% fill factor
- Wide dynamic range:
150,000 (line binning),
75,000 (area scanning)
- Low dark signal: 150 e⁻/pixel/s / 0° C, max.
- Low readout noise: 4 e⁻rms / typ.
- MPP operation

Applications:

- Fluorescence spectrometry, ICP
- Raman spectrometry
- Industrial inspection
- Semiconductor inspection
- DNA sequencing
- Low-light-level detection

Hamamatsu presents a new front-illuminated FFT-CCD area image sensor, specially designed for low-light-level detection. In particular, this image sensor is ideally suited for extremely low-light-level detection, in such fields as spectroscopy and astronomy.

The S9979 has an effective pixel size of 48 μm x 48 μm and is available with an active area of 73.728 (h) mm x 6.144 (v) mm. The sensor operates in MPP mode with very low dark current.

Author: Katrin Burgemeister
Hamamatsu Photonics Germany

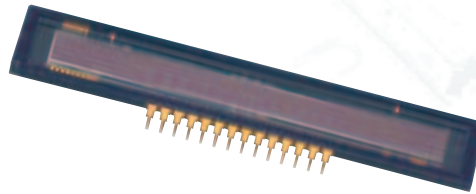

Features:

- 1536 (h) pixel x 128 (v) pixel
- Pixel size: 48 μm x 48 μm
- Time delay integration operation
- 100% fill factor
- Wide dynamic range
- Low dark signal
- Low readout noise
- MPP operation

Applications:

- Low-light-level detection
- Industrial inspection

Spectral transmittance characteristics

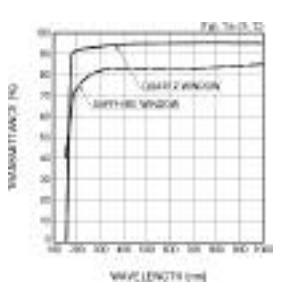

Spectral response (without window)

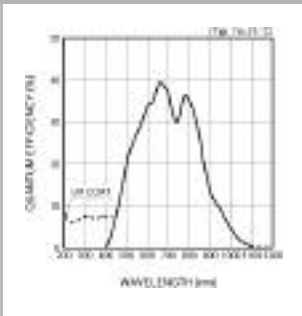

Dimensional outline

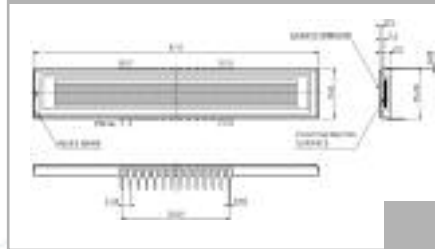

Spectral response (without window)

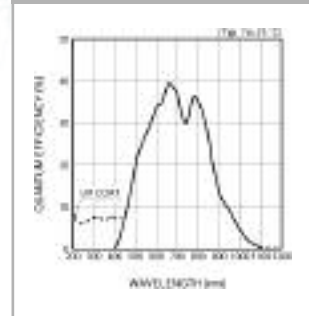

Signal integration by TDI operation

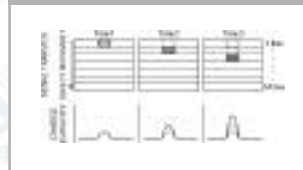

S10140/S10141 series

New CCD for Low-Light Scientific Applications

Low-light-level applications in science and industry put high demands on the performance of a CCD sensor. Low noise and high resolution are the key characteristics needed for such applications.

The new S10140/S10141 series has been specifically designed to meet these demands. Utilizing back-thinning technology, the S10140/S10141 features a low readout noise of 6 electrons RMS, small pixel size, low dark current and high quantum efficiency of 90% at peak wavelength. These features allow the user to integrate the image over a long time.

Author: Henrik Sievers
Hamamatsu Photonics Norden

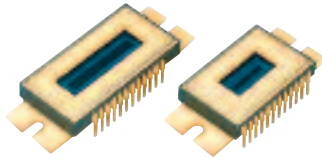

Features:

- Back thinned for high sensitivity
- Low readout noise
- High resolution: pixel size 12 μm x 12 μm
- Line or pixel binning and area scanning
- Better than 90% quantum efficiency at peak
- Pin compatible to existing S7030/S7031 family
- Non-cooled or one-stage peltier versions
- 6 sizes, from 1024 pixel x 122 pixel to 2048 pixel x 506 pixel

Applications:

- Fluorescence spectroscopy
- ICP spectroscopy
- Industrial inspection under low-light conditions
- Semiconductor inspection
- DNA sequencing
- General low-light-level detection

Dark current vs. temperature

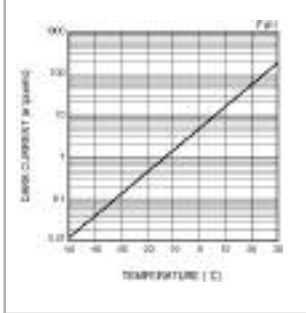

Spectral response (without window)

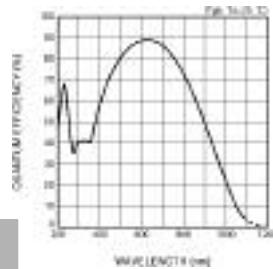

S10226 / S10227

CMOS Linear Image Sensor

The new S10226 and S10227 are developed for applications where a high cost-performance and/or a very small package are necessary. They use the same chips as in our well established S9226 (in the S10226) and S9227 (in the S10227).

S10226 offers high resolution of 1024 pixel at 7.8 μm pixel pitch, with a video data rate of 200 kHz max. A charge amplifier is integrated on the video line.

S10227 offers very high speed of 5 MHz max. data rate, with a resolution of 512 pixel at 12.5 μm pixel pitch.

The spectral response range for both devices is between 400 nm and 1000 nm.

Author: Andreas Hafner
Hamamatsu Photonics Germany

S10226 Dimensional outline

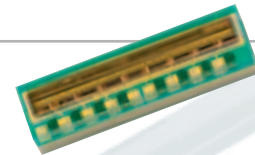
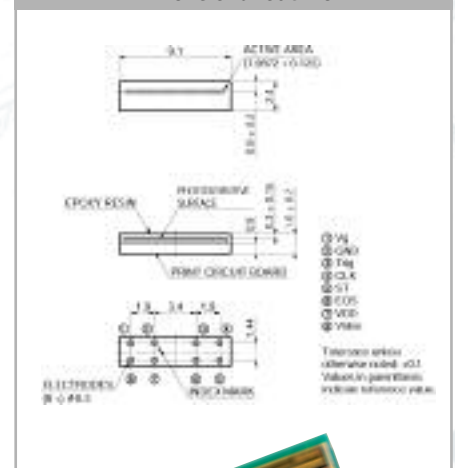

SPIE Annual Meeting (San Diego Convention Center, San Diego, CA)
Aug 15-17, 2006

CMOS Linear Image Sensor

Features:

- Compact and high cost-performance compared to the conventional types (S9226, S9227)
- Surface mount type: small package
- S10226: pixel pitch: 7.8 μm
pixel height: 125 μm
number of pixels: 1024 ch
- S10227: pixel pitch: 12.5 μm
pixel height: 250 μm
number of pixels: 512 ch
- Video data rate: 200 kHz max. (S10226)
5 MHz max. (S10227)

Applications:

- Barcode reading
- Displacement metering
- Refractometry
- Interferometry
- Miniature spectrometry

The new S10077 is a CMOS linear image sensor designed for image-input applications. The signal processing circuit has a charge amplifier with excellent input and output characteristics. Data rates are 500 kHz max. in 10-bit resolution, and 1 MHz max. in 8-bit resolution. The circuit also includes an 8-bit/10-bit AD converter on chip.

The newly designed LCP (liquid crystalline polymer) package, including a TENPAX window, offers a spectral response range from 400 nm to 1000 nm.

Author: Andreas Hafner
Hamamatsu Photonics Germany

Features:

- Pixel pitch: 14 μm
- Pixel height: 50 μm
- Number of pixels: 1024 ch
- Single-power supply operation: 3.3 V to 5 V
- On-chip charge amplifier
- Video data rate: 1 MHz max.
- Spectral response range: 400 nm to 1000 nm
- Digital output
- 8-bit/10-bit switchable ADC
- Simultaneous charge integration and variable integration time function

Applications:

- Analytical instruments
- Position detection
- Image reading

S10227
Dimensional outline

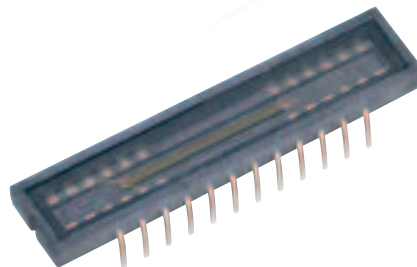
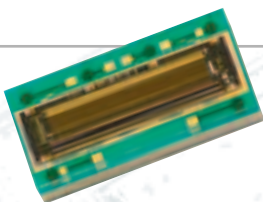
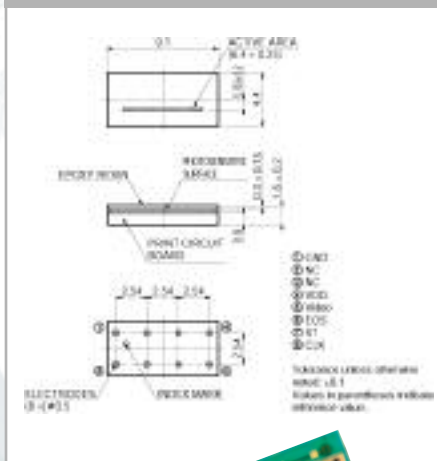

Spectral response
(typical example)

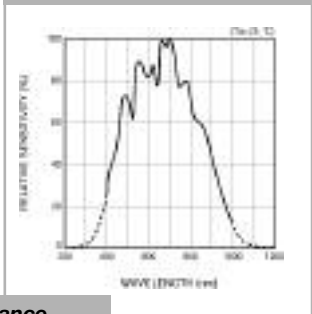

Dimensional outline (tolerance
unless otherwise note ± 0.1)

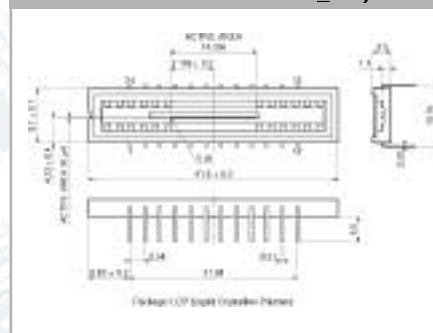

S9904

Photodiode for SEM Surface Studies

Scanning electron microscopy (SEM) is a common method to study the surfaces of materials within chemistry, material science, geology and biology.

In SEM, an electron beam is swept over the surface of the sample. When electrons hit the surface, various reactions may occur. Here we are interested in the back-scattered electrons coming from the surface.

A scintillator, converting the radiation to visible light, coupled to a photomultiplier tube, has traditionally detected the back-scattered electrons. However, this type of detector is quite bulky and cannot easily be placed close to the sample without disturbing the beam.

Semiconductor detectors have become more and more popular and are now dominating the field. They have lower gain than the scintillator detector, but this is offset by the possibility of placing the detector closer to the sample.

The new S9904 photodiode is specially designed to fit the requirements of SEM.

Author: Henrik Sievers
Hamamatsu Photonics Norden

Features:

- Direct detection of low-energy electrons with high sensitivity
- High gain
- Center hole to let beam pass in back-scatter SEM
- High collection efficiency, as detector may be placed close to sample (thin package)
- Electron beam trajectory undisturbed by detector due to non-magnetic wiring

Application:

- Scanning electron microscopy (SEM)

Gain vs. electron energy

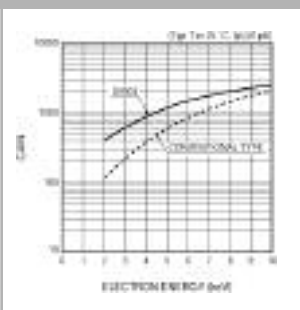

Dark current vs. reverse voltage

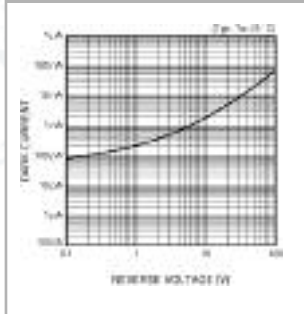

Terminal capacitance vs. reverse voltage

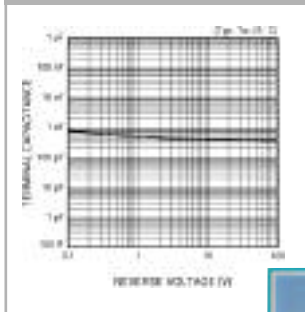

S10045

Silicon Photodiode for Monitoring High-Power Violet Laser Diodes

In order to record more than 2 hours of digital HD images on DVD, new technologies have been required in the field of the optical disc system. Recently, the demand for high-power violet or blue-violet laser diodes has increased, as these emitters are key components to increased optical disk capacity. Blue light reads and stores data at much higher densities compared to currently available, longer wavelength laser diodes.

A key point for the suppliers of such a violet laser is to use an internal monitor photodiode, which enables the output power of the laser diode to be accurately stabilized over its operating temperature range.

This could be one of the many applications of our new S10045 Si photodiode developed for accurately monitoring light output from high-power violet laser diodes.

The active area has a specially processed surface structure that maintains good photocurrent linearity up to an incident light level 10 times higher than that handled by conventional photodiodes (see figure).

By using a high-reliability metal package, the S10045 does not decrease even after exposure to high-power violet lasers. This new photodiode can also be used in all applications requiring control of high intensity light from lasers.

Author: Jean-Charles Lefort
Hamamatsu Photonics France

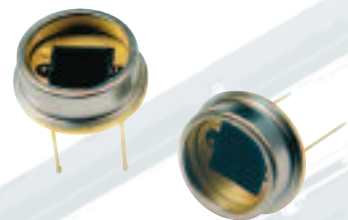

Optics East (Boston Marriott Copley Place, Boston, MA)
Oct 3-4, 2006

HAMAMATSU
Photonics

Large-Active-Area APD

Features:

- Active area: 5.8 mm x 5.8 mm
- Photo sensitivity: 15 mA/W
- High linearity

Applications:

- Aging equipment monitor for violet semiconductor laser diode
- Optical data storage for recordable optical disc
- Biomedical instrumentation
- Laser induced fluorescence

Spectral response

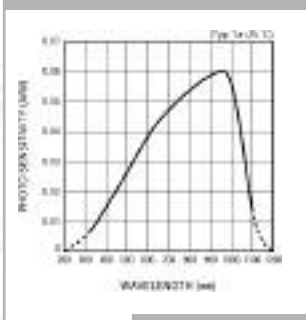

Linearity VR = 10 V

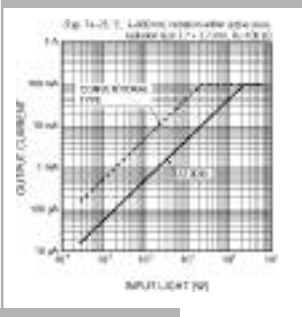

Linearity VR = 0 V

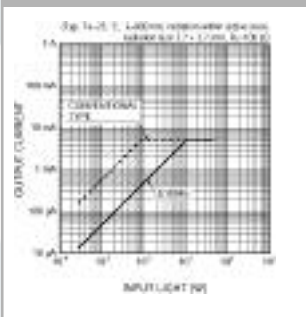

For many years, the key features of gain, sensitivity and compactness of photomultipliers and Si photodiodes have been available from silicon avalanche photodiodes.

However, it was hard to find large-active-area versions in the market as such technology was historically more dedicated to optical communication applications. To provide a large-sensitive-area detector, with high QE and low noise, Hamamatsu has developed the S8664-1010 Si APD with 10 mm x 10 mm active area. Quantum efficiency of 70% or more can be achieved, even in the short wavelength region under 500 nm. Gain up to 100 is possible, depending on the applied reverse voltage. Using superior processing techniques, a dark current of up to 10 nA at a gain of $M = 50$ has been achieved.

The S8664-1010 has a ceramic package and an epoxy resin window material, which enables efficient coupling to scintillators and is ideally suited as a detector for low-radiation-level measurement. For these applications the S8664-1010 features immunity to magnetic fields and low power consumption, which cannot be provided by conventional PMTs.

Hamamatsu also supplies a complete line-up of short-wavelength Si APDs with similar ceramic packaging and can also package a smaller active area.

Author: Jean-Charles Lefort
Hamamatsu Photonics France

Features:

- Large active area: 10 mm x 10 mm
- Terminal capacitance: 270 pF
- High multiplication factor
- Excellent spatial response uniformity within active area
- Cut-off frequency ($M = 50, \lambda = 420 \text{ nm}$): 11 MHz

Applications:

- Radiation measurement coupling with scintillator
- X-ray or gamma-ray measurement
- Analytical equipment
- Low-level photometry

Spectral response

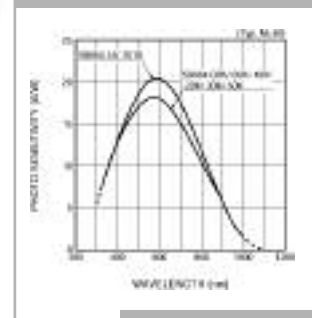

Quantum efficiency vs. wavelength

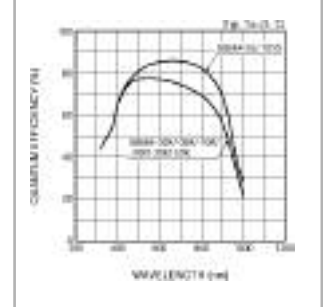

Dark current vs. reverse voltage

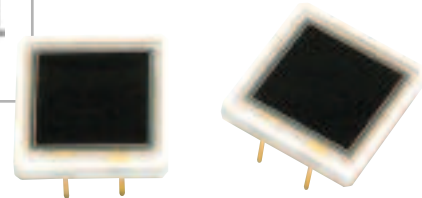
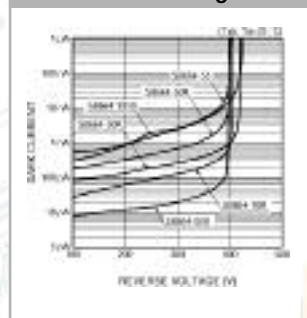

FiO (Riverside Convention Center, Rochester, NY)
Oct 10-11, 2006

S10085

Photo IC with Close-to-Human-Eye Response and CdS-Cell-Shaped Housing

The new S10085 complements our existing range of Photo ICs.

The S10085 is an ideal lead-free replacement for CdS, as it has the same housing as a 5R CdS cell and features excellent linearity compared to CdS cells and is easy to use. It is ideal for high-volume applications, such as brightness control of lamps, TFT screens and all kinds of displays.

Author: Dieter Habben
Hamamatsu Photonics Germany

Features:

- Simple operation
- Lower output-current fluctuations compared to phototransistors and CdS photoconductive cells
- Excellent linearity
- Small tolerance for light sources producing the same illuminance at different color temperatures

Applications:

- Liquid-crystal-monitor backlight dimmer for mobile devices
- Brightness adjustment for large-screen liquid crystal TVs
- Lighting dimmers
- Replacement for CdS photoconductive cells

Spectral response

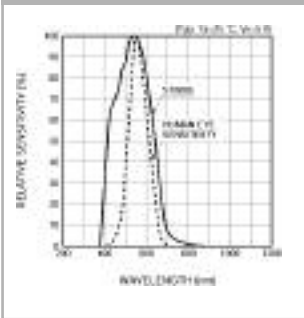

Linearity

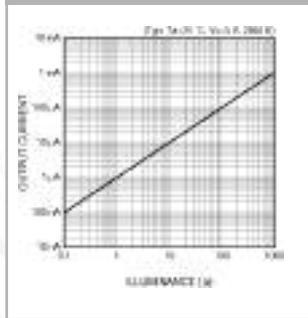

Rise/fall times vs. load resistance

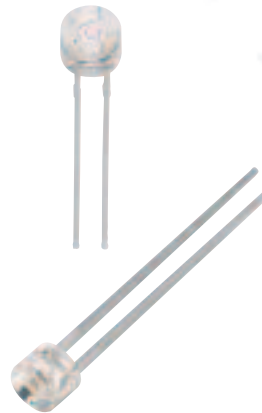
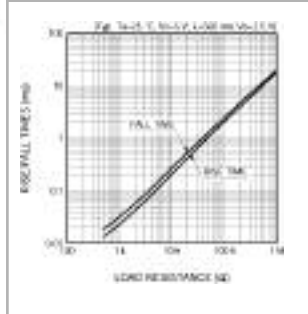

S10084 / S10115

Visible-Response Phototransistors

To complement our existing range of visible photodiode and photo IC sensors, we have introduced the new S10084 and S10115 range of visible-response phototransistors. The new phototransistors are cheaper to mass produce and are ideal for higher-volume consumer and industrial control applications. They feature an amplified current output, which is often more convenient for the end-user compared to a traditional visible photodiode.

High-volume, low-cost consumer and industrial applications have traditionally used photoconductive cells (sometimes called LDRs—“light dependent resistors”). These cells are fabricated from Cadmium (actually CdS is the semiconductor material utilized), the use of which will become illegal under European RoHS regulations starting July 1, 2006. In view of this directive and Hamamatsu’s own environmental policy, we will terminate manufacture of CdS beginning June 2006. Our new range of visible phototransistors, photo ICs and photodiodes offer a superior technical solution that is clean and environmentally friendly. To aid switch-over to a silicon solution, Hamamatsu offers the S10084 in a package that is compatible with our existing, small CdS photoconductive cells. For customers with space constraints, the new S10115 miniature-surface-mount version is ideal.

Author: Tim Stokes
Hamamatsu Photonics U.K.



S10084



S10115

S10084 Dimensional outline

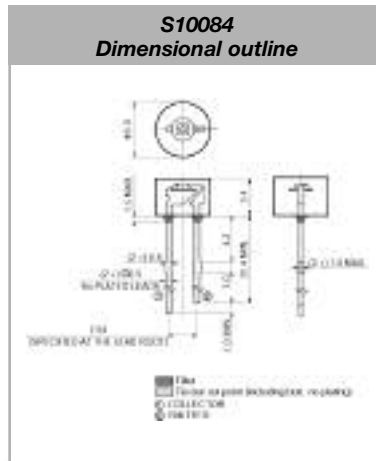

S10115 Dimensional outline



Society for Neuroscience (Georgia World Congress Center, Atlanta, GA)
Oct 14-18, 2006

Natural Colors on Your TFT

Features:

- Visible photosensitivity, approximation to human eye
- Low cost
- High-output signal current
- Package is compatible with CdS photoconductive cells
- Miniature-surface-mount style package available

Applications:

- Automatic street light controllers
- Automatic office light controllers
- Automatic illumination controller—light dimmers
- Brightness controllers for large LCD screens and other displays
- Automatic contrast-control function
- Automotive light controllers
- LCD backlight monitors and controllers
- Exposure meters
- Office equipment

A couple of years ago, we introduced the C9303, which was designed to monitor the output of LEDs in TFT monitors and thus help ensure the correct display of on-screen colors.

We now offer a new, improved version, the C9303-03. Completely lead-free, the C9303-03 is fully compliant with RoHS regulations. In addition, it operates with lower power consumption and over a broader temperature range. For even better performance, we can provide custom-made solutions for perfect mounting to your TFT monitor.

Author: Dieter Habben
Hamamatsu Photonics Germany

Features:

- Built-in RGB color sensor
- Sensitivity matches wavelengths of RGB-LED backlight for TFT-LCD (liquid crystal display)
- 3 ch current-to-voltage amplifiers
- Simultaneous output of 3 ch RGB photocurrent
- Configuration and size suitable for side mounting to TFT-LCD
- Suitable for lead-free solder
- Same gain and pin assignment to conventional type C9303
- Low current consumption: 1/3 of the conventional C9303 type

Application:

- RGB-LED backlight monitor for TFT-LCDs

Directivity

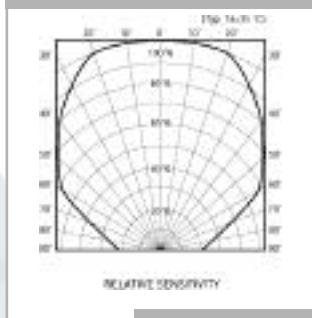

Spectral response

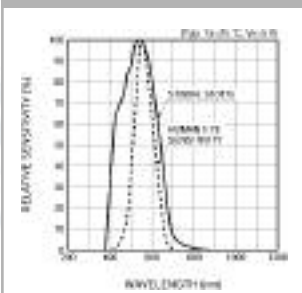

Spectral response

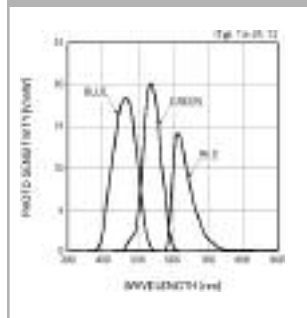

Output voltage vs. input light

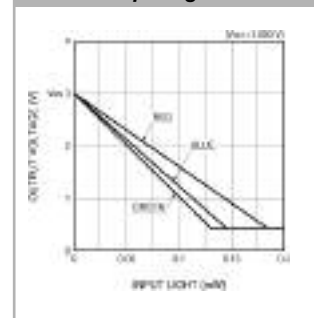

Block diagram

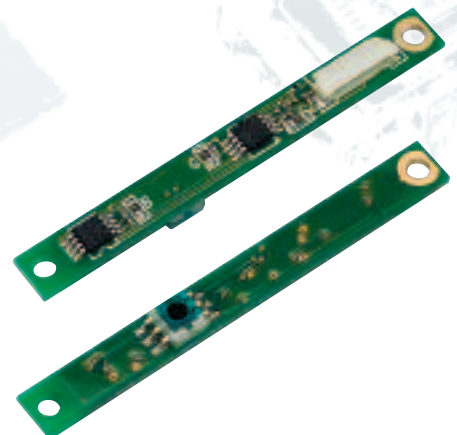
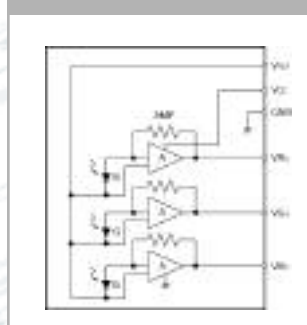

Convergence (Cobo Convention Center, Detroit, MI)
Oct 16-18, 2006

C10082MD/C10083MD**New Mini-Spectrometers for UV/VIS and VIS/NIR**

Hamamatsu has expanded its range of TG (transmission-grade) mini-spectrometers. Two new models are now available, the C10082MD for UV and visible range (200 nm to 800 nm) and the C10083MD for visible and near-infrared range (320 nm to 1000 nm).

The light is coupled into the spectrometers' entrance port through an optical fiber. The quartz transmission grating leads to a high throughput of the signal. The spectrum of the light is measured with the built-in CMOS linear image sensor. The spectrometers have a USB port for power supply and data acquisition with a PC; therefore no external power supply is required.

As with all mini-spectrometers available from Hamamatsu, the C10082MD and C10083MD are supplied with sample software for setting of measurement conditions, acquiring and saving of spectrum data and displaying it graphically. Using our software, it is simple to start basic measurements quickly and easily. In addition, a driver software package with DLL files is supplied for use with C++ and Visual Basic, allowing the user to develop their own measurement programs.

Other cooled and uncooled mini-spectrometers for spectral ranges from 200 nm up to 2200 nm are also available. For further information, please contact your local sales office.

Author: Rainer Noichl
Hamamatsu Photonics Germany

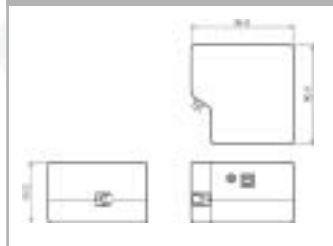

Dimensional outline

**Features:**

- High accuracy of optical characteristics
- No external power supply required
- Wide spectral response range
- Easy to install into equipment

Applications:

- Spectral evaluation of light sources
- Industrial color measurement
- Analysis of sunlight and illumination

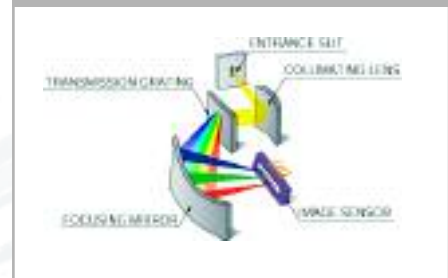
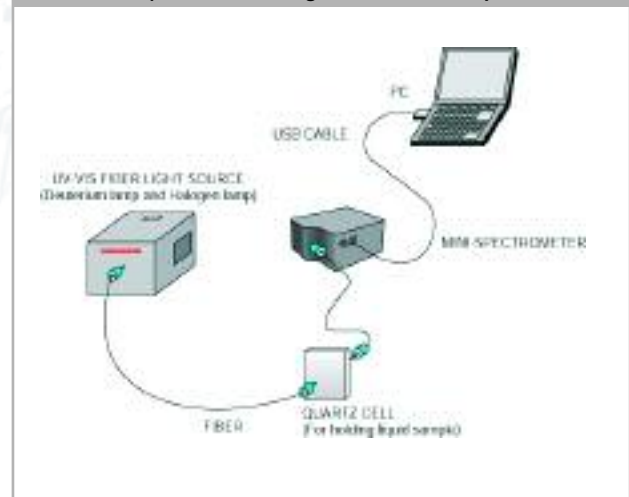
Optical component layout**Connection example
(transmission-light measurement)**

ASNT (Hilton Americas, Houston, TX)
Oct 23-25, 2006

InAs Photovoltaic Detector

To complement our comprehensive range of mid-infrared detectors, we have now launched a new range of photovoltaic InAs devices. Traditionally, near-infrared detection has been relatively easy using our range of InGaAs photodiodes, but even our specially extended-spectral-response types can only measure light up to 2.6 μm . Beyond this, the options were to either use photoconductive lead-sulfide (PbS) detectors or expensive InSb or MCT devices, which often require cryogenic cooling.

Although current PbS devices are simple to operate and give high sensitivity, their output is not very linear, making high accuracy measurements difficult. PbS photoconductive devices tend to show a large variation in output from device to device, and there is also a tendency for the output to drift over time. It is often necessary to individually calibrate each instrument using these detectors.

The new P10090 series of InAs devices solves these problems and although more expensive than PbS detectors, their ability to give highly accurate, repeatable measurements make them attractive for a number of infrared applications.

Author: Tim Stokes
Hamamatsu Photonics U.K.

Features:

- High sensitivity in the near infrared to beyond 3 μm
- Photovoltaic operation (no external voltage required)
- Very linear output for high-accuracy measurements
- Low dark current and low noise, for low-light-level detection
- Fast response speed < 1 μs

Applications:

- Near-infrared spectrophotometry
- Flammable gas sensors for safety and control systems
- Toxic gas sensors and pollution monitoring
- Near-infrared laser detection
- Industrial-process monitoring
- Flame detection and analysis
- Hot-metal monitoring
- Radiation thermometry (pyrometry)

Spectral response

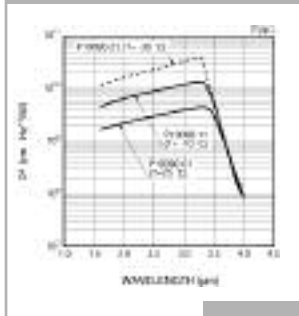

Measurement circuit

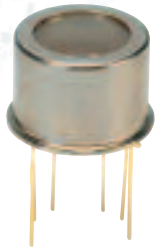
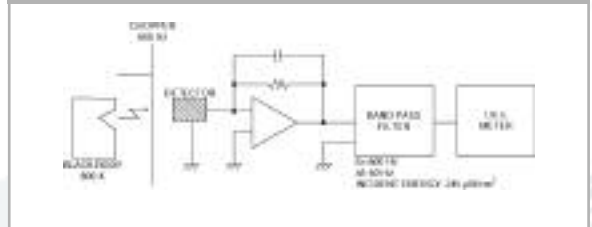

P10090-11/-21
Dimensional outline

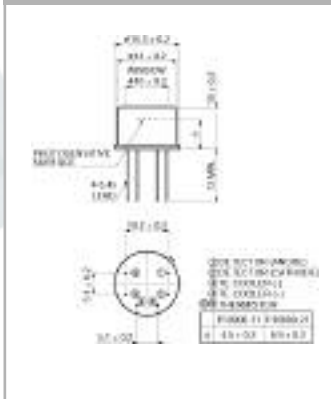

L10061, S10062

Transmitter/Receiver Photo IC for 250 Mbps Optical Link (AMI-C 1394)

The L10061 and S10062 are transmitter and receiver photo ICs, developed to communicate multimedia information, particularly for AMI-C 1394 (automotive multimedia interface collaboration) networks used in vehicles.

The transmitter photo IC L10061 consists of a red RC-LED and driver IC incorporated into a clear plastic package. It can input and detect the tone signals necessary for bus adjustment.

The receiver photo IC S10062 consists of a photodiode and amplifier IC. An optical wake-up mode detects when light is input and changes between "standby" and "startup" status. Both transmitter and receiver photo IC adopt LVDS interface and are easy to connect with a communication IC.

Author: *Andreas Hafner*
Hamamatsu Photonics Germany

Features:

- Bandwidth: 250 Mbps max.
- Wide operating temperature
- Wide dynamic range
- LVDS interface
- Low-power consumption mode
- 3.3 V single power supply

Applications:

- Vehicle networks (AMI-C 1394)
- OA/FA networks
- Home networks

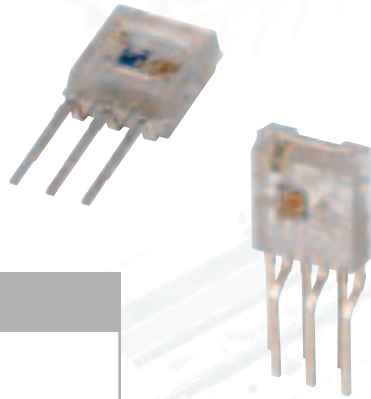

Dimensional outlines

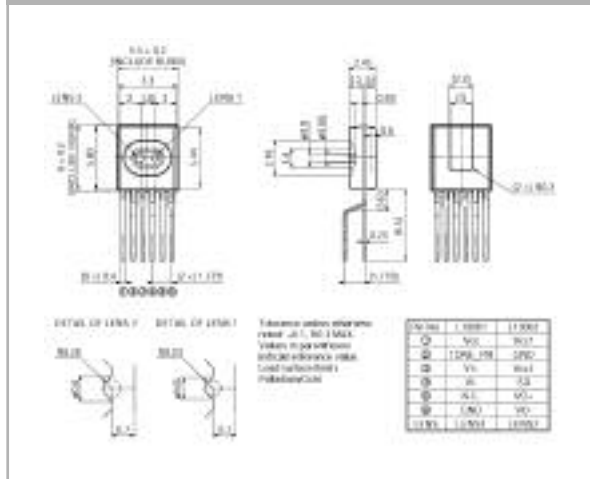

G10208-14 / G10208-54

High-Speed InGaAs PIN + TIA ROSA

The new range of G10208 InGaAs detectors from Hamamatsu Photonics have been introduced to complement our range of high-speed optical receivers for data-communication applications. The new G10208 consists of an InGaAs PIN diode connected to a high-speed pre-amplifier, giving an output voltage signal at data rates of up to 10 Gbps. To aid easy integration by the system vendor, the device is mounted in an industry-standard optical sub-assembly package, called ROSA.

Two options are available as standard: the G10208-14, with 8 pins, or the G10208-54, with flex-cable connection. The device is designed to comply with the requirements of 10 Gbase-LRM, the IEEE standard for 10 Gb ethernet data transmission over multi-mode fiber. It is anticipated that this standard, and this type of receiver, will become widely used in IT networking environments operating at very high bandwidth over relatively short distances (LAN) in the near future.

Compared to our existing range of 10 Gb receivers, the new G10208 series utilize a larger photosensitive area to give higher sensitivity from multi-mode fiber (MMF).

Author: *Tim Stokes*
Hamamatsu Photonics U.K.



Auto Testing Expo (Novi Convention Center, Novi, MI)
Oct 25-27, 2006

High-Speed InGaAs APD + TIA ROSA

Features:

- Very high speed response: 10 Gbps
- Low operating voltage: 3.3 V
- Industry-standard ROSA package, with 1.25 mm diameter sleeve
- High sensitivity and wide dynamic range: + 2 dBm to -19 dBm typically
- Larger sensitive area (compared to devices designed for single mode fiber)
- Built in AGC (automatic gain control)
- Differential amplifier output

Applications:

- High-speed data communications over multi-mode fiber (MMF)
- 10 Gb ethernet over LAN (particularly 10 Gbase-LRM standard)

The new G10204-54 InGaAs APD detector from Hamamatsu Photonics has been introduced to complement our range of high-speed optical receivers for data communication applications. The new G10204-54 consists of an InGaAs APD connected to a high speed pre-amplifier, giving an output voltage signal at data rates of up to 10.7 Gbps. To aid easy integration by the system vendor, the device is mounted in a metal optical sub-assembly package, called ROSA, which is compatible with the XMD industry standard. The G10204-54 has isolated housing and signal ground, with external connection being made with flex board interface.

Compared to our current range of 10 Gb ROSA devices, such as the G9911, the new G10204 incorporates an APD receiver. This provides on chip signal gain, and then higher sensitivity (-27 dBm with M = 7 at 10.7 Gbps), allowing data transmission over much longer distances compared to existing devices.

Author: Tim Stokes
Hamamatsu Photonics U.K.

Features:

- Very high speed response: > 10 Gbps
- Low operating voltage: 30 V APD breakdown
- Industry-standard ROSA package, compatible with XMD-MSA standards
- High sensitivity and wide dynamic range: -5 dBm to -27 dBm typically
- Low optical-return loss: typically 35 dB
- Isolated package

Applications:

- High-speed data communications
- Long-haul telecommunication systems
- 10 Gb data transmission over MAN and WAN

Frequency response

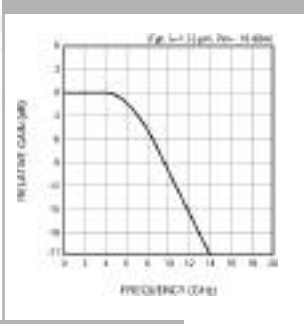

Maximum receivable sensitivity

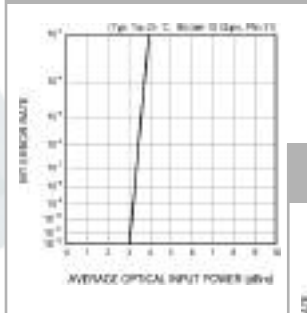

Minimum receivable sensitivity

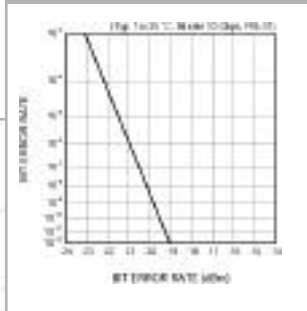

Bit error rate

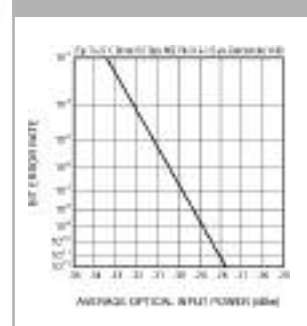

Rapid Optical Bench

New DP-Type Socket Assembly

The new Hamamatsu optical block product range enables researchers, scholars and engineers to compose their optical system by simply attaching the new optical blocks to each other, and then to a photomultiplier detector module. These new products are quick and easy to set up, saving the user time normally spent on complex set-up, adjustment and design of an optical system.

The optical block is a compact unit containing optical components such as bandpass and dichroic filters. Optical components are accurately arranged in angular "minutes" by high-precision machining technology. The joint section is fully light-shielded by its V shape and an O-ring. It can easily be attached to another block or removed using the thumb screw, to allow any desired combination of blocks.

Suitable PMT Modules:

H5773/H5783/H6779/H6780/H9858/H5784/H9656/H7155/H7467/H7468

For information on other photomultiplier tube (PMT) modules, contact our sales office.

Author: Georg Kloppenburg
Hamamatsu Photonics Germany

Features:

- Easy to attach and detach
- No alignment required
- Light-shielding

Products:

A10032, A10033
filter block & ND filter block



A10034, A10035
dichroic block & beam splitter block



A10031
beam expander block



A10030
adapter block



A10037
fiber adapter block



Hamamatsu offers a wide variety of accessories specifically designed for simple and reliable operation of PMTs. The C9773 is the latest addition to this line-up.

The C9773 is a high-voltage power-supply socket assembly designed for 25 mm (1 inch) diameter head-on photomultiplier tubes (PMTs). Weighing only 60g, it incorporates a high-quality socket and a regulated high-voltage power supply with an active-voltage divider integrated in the same compact package. No time-consuming wiring is required, and PMT operation is very easy. Just supply +15 V and connect to an external potentiometer or apply a low external control voltage from 0 V to +5 V for high-voltage adjustments.

The output voltage can be adjusted in the range from 0 V to -1250 V externally. The high-voltage power supply is designed to conform to the stability requirements demanded by PMT operation.



C9773/C9028-01

Dimensional outline

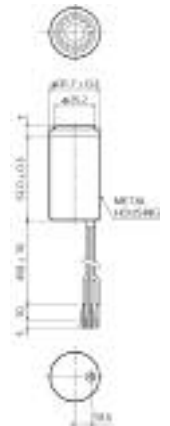

Set-up example

ISTFA (Renaissance Hotel at the Arboretum Rio Grande Exhibit Hall, Austin, TX)
Nov 12-16, 2006

DP-Type Socket Assembly for 28 mm Diameter Head-on PMTs

To improve linearity, it is important to minimize changes in the inter-stage voltage when photocurrent flows through the PMT.

A transistor circuit, added to the circuit components of the voltage divider, forms an active-voltage divider circuit, ensuring excellent linearity with low power consumption.

Author: Andrey Makarets
Hamamatsu Photonics Norden

Features:

- Superior DC output linearity
- Fast high-voltage programming response
- Wide high-voltage output range
- Low ripple noise
- Compact and lightweight

Application:

- Compatible with our PMTs:
R1924A, R1925A, R3550A, R5070A

Linearity characteristics

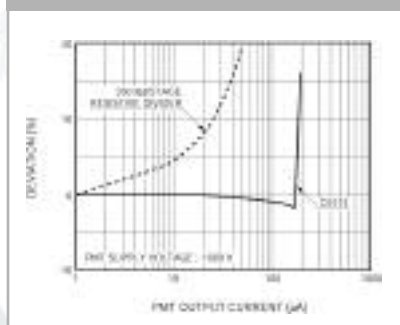

A high-voltage power supply is usually required to operate a photomultiplier tube (PMT). It is also necessary to distribute voltage to each dynode of the PMT independently, i.e. a voltage-divider circuit is needed in order to divide the high voltage and provide a proper voltage gradient between each dynode.

Is it possible to combine both the high-voltage power supply and the voltage-divider circuit into one compact package—in order to simplify PMT operation?

Hamamatsu's answer is: "Yes!" We offer compact assemblies consisting of a stable high-voltage power supply and voltage-divider circuit, all in a single, lightweight package. One example is the C9028-01. This high-voltage power-supply socket assembly is suitable for 28 mm (1-1/8 inch) diameter head-on PMTs, such as R6094, R374, R5929, R2228 etc. It enables stable PMT operation with excellent DC output linearity due to the presence of an active divider circuit, which has transistors in place of dividing resistors in the last few stages.

The incorporated high-voltage power supply allows a wide range of high-voltage adjustments with fast high-voltage programming response. There are two modes of high-voltage control, either using an external potentiometer or an applied external voltage 0 V to +5 V.



C9773/C9028-01

The input voltage range is +15 V (+/-1 V). Using the C9028-01, PMT operation is very easy and simple, combining a +15 V power supply and divider circuitry.

Author: Andrey Makarets
Hamamatsu Photonics Norden

Features:

- Superior DC output linearity
- Fast high-voltage programming response
- Wide high-voltage output range
- Low ripple noise
- Compact and lightweight

Application:

- Compatible with the following PMTs:
R6094, R374, R5929, R2228 etc.

Dimensional outline

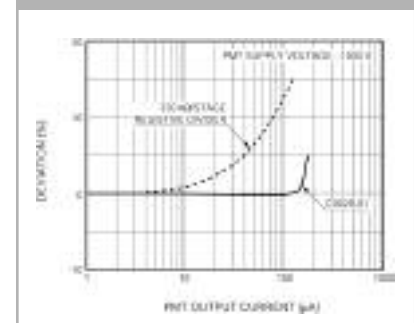

Practical PMT output limits

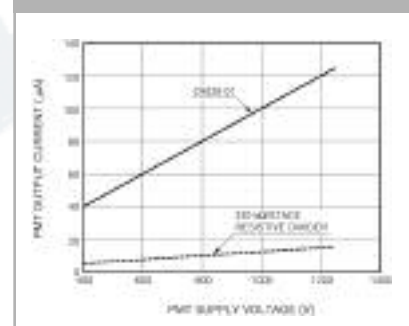

MRS Fall Meeting (Hynes Convention Center, Boston, MA)
Nov 28-30, 2006

HAMAMATSU
Photonics

R3809U-68/-69**High-Speed MCP-PMTs for Infrared Imaging**

Hamamatsu's new microchannel plate PMTs provide the dual benefits of an extended NIR range and fast response times. The R3809U-68 is designed with an InP/InGaAsP photocathode and has a spectral response range from 950 nm to 1400 nm. The R3809U-69 goes out even further (to 1700 nm) due to its InP/InGaAs photocathode. In terms of speed, both models typically have a transit-time spread of 70 ps. Gain is typically 2×10^5 . These unique PMTs can be especially useful for applications such as optical CT, optical communications research, nanoparticle research, and materials science. In semiconductor analysis, for example, the R3809U-68/-69 could be used to look for microprocessor design flaws by detecting the internal waveform of microprocessors. Operation of either PMT requires Hamamatsu's C10221 cooling unit.

Author: Leo Kohyama
Hamamatsu Photonics U.S.A.

Features:

- Wavelength range:
 - R3809U-68: 950 nm to 1400 nm
 - R3809U-69: 950 nm to 1700 nm
- Transit-time spread: 70 ps
- Rise time: 170 ps
- Typical gain: 2×10^5
- Photocathode area: 2 mm diameter
- Outer diameter: 45.0 mm

Applications:

- Optical computed tomography
- Optical communications research
- Semiconductor analysis
- Crystal research
- Molecular structure analysis
- Nanoparticle research
- Fast gene sequencing

V8071U-66-G130**Image Intensifier with Extended Infrared Range**

The V8071U-66-G130 reaches further into the near-infrared spectrum than most image intensifiers, which makes it excellent for detecting signals away from the blue region of the spectrum, where autofluorescence is found. Applications include Raman spectroscopy of biological compounds and tissue, video microscopy, and optical biopsy. Also, like the V9569U-71-G130 (Hamamatsu's other new image intensifier), the V8071U-66-G130 can be used for spectroscopic measurement of blood perfusion and oxygenation. Key features of this product are a wide spectral response range (360 nm to 1100 nm), fast gating time (5 ns), and a fiber-optic output window that allows it to be fiber-optically coupled to a CCD sensor.

Author: Leo Kohyama
Hamamatsu Photonics U.S.A.

Features:

- Wavelength range: 360 nm to 1100 nm
- Peak response: 700 nm to 800 nm
- Photocathode: InGaAs
- Effective area: 13.5 mm x 10.0 mm
- Gating time: 5 ns
- Luminous gain: 7.0×10^5 (lm/m²)/lx

Applications:

- Raman spectroscopy
- Video microscopy
- Optical biopsy
- Tissue spectroscopy
- Optical computed tomography
- Quantum dot emission



V9569U

V8071U

American Society for Cell Biology (San Diego Convention Center, San Diego, CA)
Dec 9-13, 2006

HAMAMATSU
Photonics

V9569U-71-G130

Highly Sensitive Image Intensifier with Large Active Area

The V9569U-71-G130 proximity-focused image intensifier is an especially good match for video microscopy with red-sensitive dyes because of its high quantum efficiency (typically 23%) between 650 nm to 750 nm. It is also ideal for applications in tissue spectroscopy (such as measuring blood perfusion and oxygenation in tissue), optical biopsy and optical computed tomography. This new image intensifier can be fiber-optically coupled to a CCD for use in an intensified CCD camera. Other advantages for equipment design include a large active area (16.0 mm x 16.0 mm, min) and fast gating time (5 ns).

Author: Leo Kohyama
Hamamatsu Photonics U.S.A.

Features:

- Wavelength range: 370 nm to 920 nm
- Peak response: 650 nm to 750 nm
- QE at peak: 23 %
- Photocathode: GaAs
- Effective area: 16.0 mm x 16.0 mm
- Gating time: 5 ns
- Luminous gain: 3.0×10^4 (lm/m²)/lx

Applications:

- Video microscopy
- Optical biopsy
- Tissue spectroscopy
- Optical computed tomography



V9569U

V8071U

H9666

Fluorescence-Detection Unit

The fluorescence-detection unit (FDU) contains 6 sets of optical filters and photomultiplier tube (PMT) modules. It can detect 5 wavelengths of fluorescence as well as laser-scattering simultaneously.

The optical filters are designed to correspond to fluorescence wavelengths and give a high rejection ratio for other wavelengths. Gain can be adjusted for every PMT module, each of which corresponds to a different wavelength.

The FDU is ideal for simultaneous measurement of multiple fluorescence signals.

It is a small, ready-to-use package of 15 cm x 16 cm x 8.5 cm.

Author: Arie van Gool
Hamamatsu Photonics Germany

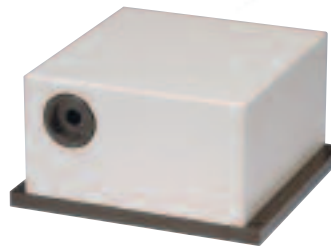

Construction

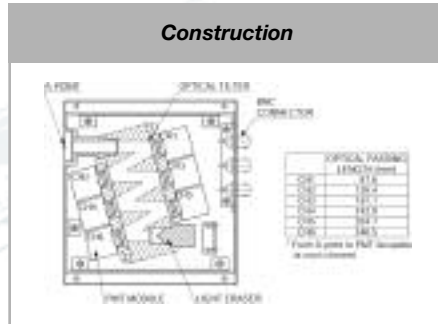

Features:

- Measurement of 5 fluorescence wavelengths simultaneously
- Adjustable gain for each PMT module (wavelength)
- Ready to use (optics/filters/pmt modules in one package)
- Compact size (15 cm x 16 cm x 8.5 cm)

Applications:

- Flow cytometry
- MTP readers
- DNA analytical instruments
- Fluorescence spectroscopy
- Micro fluid chips
- Laser scanning microscopy

Radiant sensitivity

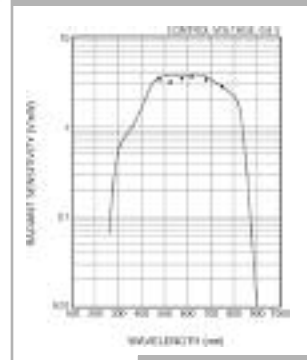

Sensitivity adjustment

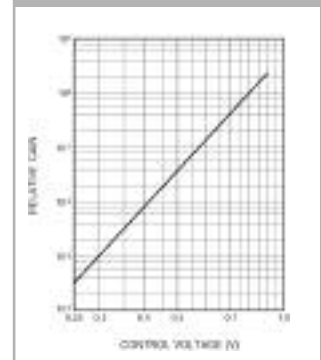

BIOS (San Jose Convention Center, San Jose, CA)
Jan 20-21, 2007

R9454

UVTRON R9454 for Flame Detection

Fire detection and the monitoring of combustion are usually accomplished by the use of sensors to detect temperature, smoke, light, etc. However, the response speeds of conventional methods are rather low. Visible and infrared sensors require additional devices to prevent false alarms due to background sunlight, room illumination, or excessive heat from fireplace walls.

A high-speed response in the detection of flames (or the absence of flames!) without the interference of the other light spectrum is possible due to the UVTRON's high sensitivity to ultraviolet rays (185 nm to 260 nm).

The newly introduced R9454 is vibration- and shock-proof, around the same level as semiconductor devices (guaranteed shock resistance is 1000 G, shock-absorption time of 1 ms).

A driver/signal-processing circuit (C3704) is also available from Hamamatsu Photonics.

Author: Arie van Gool
Hamamatsu Photonics Germany

Features:

- Highly resistant to vibration and shock
- Optical visible-cut filter not required
- High sensitivity
- Driving circuit (C3704) available

Applications:

- Flame detectors for gas/oil lighters and matches
- Fire alarm
- Combustion monitors for burners
- Inspection of ultraviolet leakage
- Detection of discharge (corona discharge of high-voltage transmission lines, etc)
- Ultraviolet switching



R9454

R4110U-74 Series

New MCP-PMT Series with High Sensitivity

Featuring high quantum efficiency in the visible spectrum (typically 40% at 530 nm) and high time resolution (100 ps transit-time spread), the R4110U-74 microchannel plate PMTs are excellent detectors for biological applications such as low-light fluorescence measurement and time-resolved spectroscopy.

In addition, these new PMTs provide multi-channel detection so that the time response of multiple wavelengths can be measured — a feature that contributes to improved accuracy in FRET measurements. Other suitable applications for the R4110U-74 series are laser ranging, laser tomography, optical CT, and fast gene sequencing. Among its key design characteristics are a GaAsP photocathode and 10 x 10 anode array.

Author: Leo Kohyama
Hamamatsu Photonics U.S.A.

Features:

- Wavelength range: 280 nm to 720 nm
- Peak response: 530 nm
- QE at 530 nm: 40%
- Photocathode: GaAsP
- Photocathode area: 25 mm diameter
- Transit-time spread: 100 ps
- Rise time: 200 ps
- Typical gain: 3×10^5

Applications:

- Fluorescence lifetime measurement & imaging
- Fluorescence resonance energy transfer (FRET)
- Time-resolved fluorescence measurement
- Time-resolved spectroscopy
- Laser ranging
- Laser tomography
- Optical computed tomography
- Fast gene sequencing



L9421

Compact Sealed Micro-Focus X-Ray Source

The new L9421 is the latest addition to our comprehensive range of sealed-type micro-focus X-ray sources. Unlike previous models, the L9421 contains the X-ray tube (head), power supply, cooling and control electronics, all within a single unit. It is also possible to control using a remote PC, via the built-in RS-232C data interface. The L9421 is simple to use, saves space and reduces cost. The Hamamatsu sealed MFX head allows maintenance-free operation, as there is no need for routine regular filament replacement or target cathode repositioning as required by other MFX sources, greatly reducing operating costs to the end user.

Author: Tim Stokes
Hamamatsu Photonics U.K.

Dimensional outline

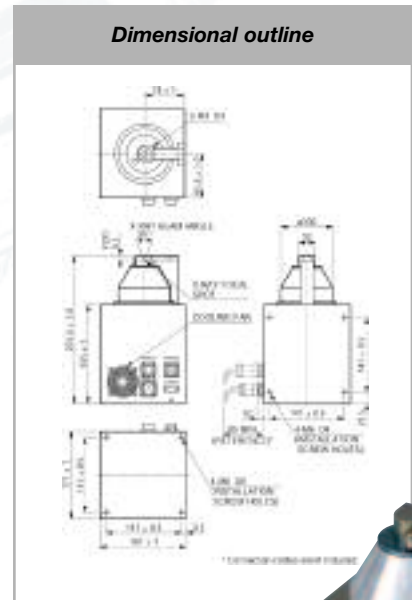

Photonics West (San Jose Convention Center, San Jose, CA)
Jan 23-25, 2007

Direct X-Ray Imaging CCD Cameras

Features:

- Sealed, maintenance-free micro-focus X-ray tube
- Integrated high-voltage power supply
- Integrated X-ray tube controller
- Remote PC control possible via RS-232C serial data interface
- Air-cooled, no oil emersion required
- X-ray voltage from 20 kV to 90 kV
- Small focal spot size down to 5 μ m
- Compact size
- Short field of depth (FOD) of < 10 mm

Applications:

- X-ray non-destructive inspection of printed circuit boards
- X-ray non-destructive inspection of semi-conductors
- X-ray non-destructive inspection of other electrical components
- X-ray non-destructive inspection of metallic, wooden and plastic components
- X-ray CT (3-D X-ray imaging)

Tube current operational range

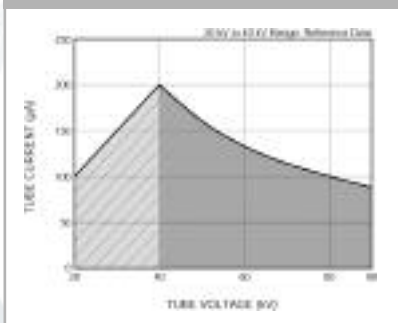

In addition to our X-ray imaging cameras with scintillators, we also offer a variety of cameras for direct X-ray exposure without the need for scintillators. With direct X-ray exposure, a significant improvement in lateral resolution and dynamic range can be achieved. The field of view is determined by the size of the CCD chip, available from 8 mm x 8 mm to 13.3 mm x 13.3 mm. The lateral resolution reaches up to 1024 pixel x 1024 pixel with A/D conversion up to 16 bit and a maximum frame rate of 30 Hz.

Depending on the incident X-ray energy, three different CCD types can be selected. From 3 keV to 10 keV, a front illuminated CCD is offered; for lower energies between 2 eV and up to 10 keV, back-thinned CCDs are available; and for higher energy levels, above 10 keV, we can supply special deep-depletion-layer CCDs.

Usually the cameras are used under vacuum conditions, for which different vacuum flanges can be offered. For applications under atmospheric conditions, a Beryllium window-sealed CCD chip is available. For high-performance applications requiring

low readout noise, air-cooling circulating water or liquid Nitrogen options can be used. The cameras communicate with a computer via standard CameraLink — or IEEE1394 (FireWire) — interfaces.

Author: Bertram Lohmüller
Hamamatsu Photonics Germany

Features:

- High lateral resolution up to 1024 pixel x 1024 pixel
- High dynamic range of up to 1:28.750 (full well capacity/readout noise)
- High A/D conversion of up to 16 bit
- Large X-ray energy range between 2 eV to more than 10 keV
- Low readout noise down to 6 electrons
- High frame rate up to 30 Hz

Applications:

- X-ray microscopy
- X-ray telescope
- X-ray spectroscopy
- Micro-CT
- EUV-lithography
- X-ray energy analysis

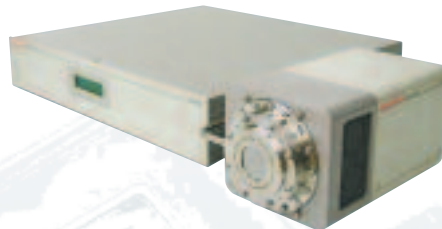

Direct X-ray camera model C4742-98-KAD with Beryllium window

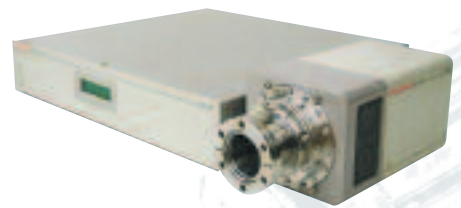

Direct X-ray camera model C4742-98-LAD with vacuum chamber flange



Direct X-ray camera model C8000-20D with high frame rate

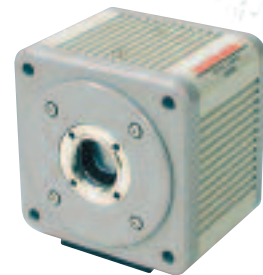

Direct X-ray camera model C8800-01C with Beryllium window and high frame rate

MDM West (Anaheim Convention Center, Anaheim, CA)
Feb 13-15, 2007

X-Ray Flat-Panel Sensor (FPS)

Flat-Panel Sensor Product Line Extended

Industry demands for higher levels of quality assurance are a permanent challenge to our design engineers. Hamamatsu meets this challenge, offering state-of-the-art devices to provide the solutions to meet our customers' needs.

Our newly developed SK series of flat-panel sensors utilize a fiber-optic plate (FOP), deposited with a gadolinium oxysulfide scintillator (GOS). This construction protects the CMOS photodiode array against high-energy radiation up to 150 kVp. Compared to our standard flat panels, which use either directly or indirectly deposited Cesium Iodide (CsI) as their scintillator, the SK series guarantees six times longer life, up to 6 million roentgen.

C10013SK is a new SK flat panel using an "active-pixel construction", where every single pixel is equipped with its own amplifier, instead of only one trans-impedance amplifier, for each column of pixels. Thanks to this new feature, the noise level of the C10013SK flat panel is reduced by almost one order of magnitude. The low noise or high signal-to-noise ratio addresses applications such as high-quality imaging or low-contrast objects.

C9312SK combines a large sensitive area with high resolution and high frame rate. This 5.7 mega-pixel flat-panel sensor features two output taps to achieve a data rate of 8 frames per second, enabling optimal performance in high-throughput applications.

C9321SK-05 is a high-radiation-level version of the C9321CA-02 high-speed sensor.

*Authors: Stefan Kappelsberger, Martin Brückner
Hamamatsu Photonics Germany*

Features:

- Drastically reduced noise level
- Energy range up to 150 kVp
- Long lifetime: 6 million roentgen
- High frame rates

Applications:

- Radiography
- In-line non-destructive testing
- Industrial CT

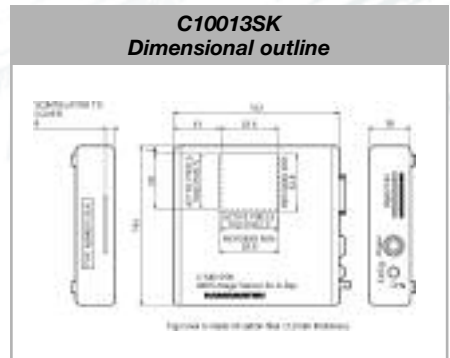
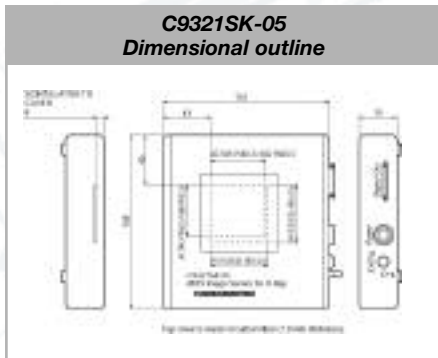
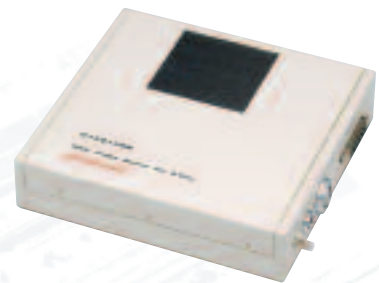
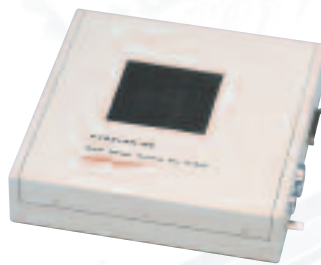

Specifications:

Application	Type No.	A/D (bits)	Pixel size (µm)	Photodiode area (mm)	Resolution (LP/mm)	Frame rate* (frames/s)	Scintillator	X-ray tube voltage (kVp)	Top cover material
Non-destructive testing	C10013SK	12	50	52.8 x 52.8	8	4	GOS deposited FOP	20 to 150	Carbon fiber
	C9321SK-05					8		20 to 150	
	C9312SK			124.8 x 115.2	9	8		20 to 110	

* Single operation

Medical Imaging (Town and Country, San Diego, CA)
Feb 20-22, 2007



Board-Level TDI Camera

The C10000 TDI line-scan camera is a new generation of Hamamatsu products designed for applications where high speed and superior image quality are required. TDI stands for “time delay integration” and is a breakthrough in high-sensitivity imaging. It produces a continuous image of a moving object by means of a stack of linear arrays. Each line is synchronized to the movement of the object in such a way that, as the image moves from one line to the next, the integrated charge moves along with it, providing higher sensitivity at lower light levels than is possible with a standard line-scan camera. This increases the signal-integration time in direct proportion to the number of rows on the sensor — 128 x in the case of the C10000 — while maintaining high-speed imaging.

The Hamamatsu C10000 is an ultra-sensitive camera for line-scan applications that demand high performance under low-light conditions. The camera has 2048 pixels spatial resolution with 128 TDI stages and bi-directional scanning operation. It supports scan rates up to 50 kHz. The back-thinned CCD sensor type offers high quantum efficiency over a great spectral range, from UV to NIR. Anti-blooming prevents localized overexposure from contaminating the information in adjacent pixels. The C10000 is a board-type camera without housing, designed to easily integrate into imaging instruments. Selectable 8-bit or 12-bit data is provided through the CameraLink interface.



The TDI line-scan camera is ideal for a wide variety of applications, including flat-panel display and electronics manufacturing inspection, sorting and routing, high-performance web inspection and other imaging applications where high speed and high sensitivity are required.

Author: Jenca Schmitt
Hamamatsu Photonics Germany

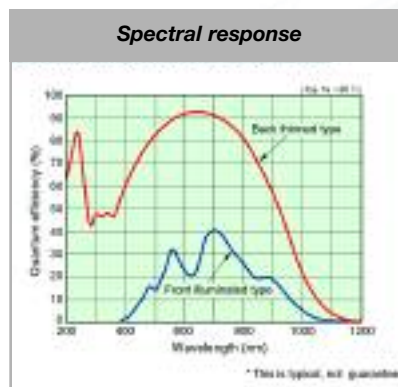

Features:

- 2048 (h) spatial resolution with 128 (v) TDI stages
- Line rates up to 50 kHz
- High-speed imaging combined with high sensitivity & low noise
- Great spectral response for UV to NIR with back-thinned CCD chip
- 100% fill factor
- 100x anti-blooming with lateral overflow drain
- 100 dB dynamic range with anti-blooming
- 12-bit/8-bit selectable A/D converter
- Bi-directional scanning operation

Applications:

- High-speed imaging for low-light applications
- Semiconductor inspection
- Electronics manufacturing and inspection
- High-speed scanning for large size samples, e. g. flat-panel displays
- Continuous imaging of high-speed moving objects

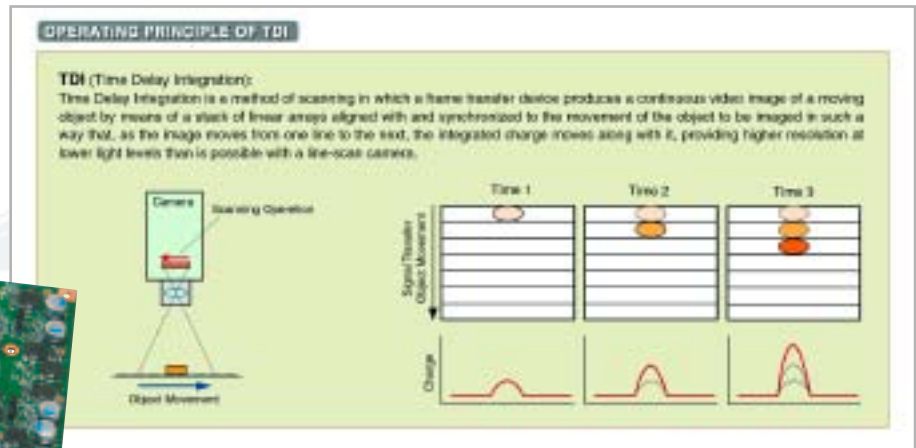

PITTCON (McCormick Place, Chicago, IL)
Mar 11-16, 2007

FA-Navigation Software

Exact localization of the failure origin is crucial in IC-failure localization. State-of-the-art tools such as the Hamamatsu PHEMOS 1000 provide several detection methods for analyzing a defective IC. Sometimes the results of these different methods are complementary, sometimes they overlap.

The failure-analysis engineer may end up with a number of images indicating several defect signals. But where is the real defect site?

One way to get further progress in analysis is by utilizing the defect images and correlating them with design information, e.g. the netlist and other CAD data. Our new software package greatly enhances the possibility to correlate information from failure-localization tools and CAD data.

As a first step, the program can overlay the information from various analysis techniques, such as emission microscopy, laser-stimulation techniques or thermal microscopy. In a second step, the program correlates the spatial defect signal information to the net information.

Using statistical methods, the user gets a table indicating the commonality among several defect sites, narrowing down the selection of candidates for the real defect site very effectively. This can greatly speed up the time for analysis and thus improve the throughput in a failure-analysis lab.

Author: Hubert Ortner
Hamamatsu Photonics Germany

Features:

- Automatic extraction of nets passing through a region on an IC where a failure signal has been acquired
- Nets are sorted to indicate which nets are likely responsible for a defect
- Seamless integration of failure analysis signals from various sources with CAD information

Application:

- IC-failure analysis

2nd Generation InGaAs Camera for Emission Microscopy

Driven by the progress in design and production of integrated circuits, the demand for highly sensitive cameras is increasing in IC-failure analysis. Customers are continuously asking for better detection efficiency, higher resolution and better image quality in order to detect very faint emission signals.

Hamamatsu has now completed the development of the second generation of cameras for emission microscopy using an InGaAs focal plane array. InGaAs cameras are sensitive in the spectral range from 900 nm to 1600 nm, and they currently offer the highest sensitivity for emission microscopy in this wavelength range. The sensor for the new camera has been designed to reach higher sensitivity and resolution by applying advanced production technology.

While the first-generation camera had an array with 320 pixels x 240 pixels, the second-generation array has 680 pixels x 512 pixels. This improves the possibility of exactly localizing defects on the devices.

We can also now achieve a very low-dark-current rate, 10 to 20 times lower than the previous generation, allowing the detection of much weaker emission signals than ever before.

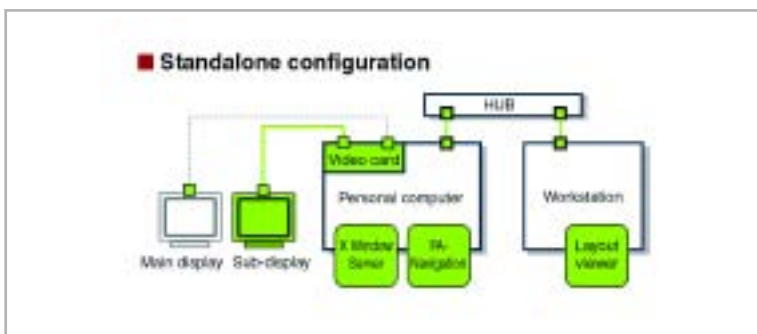
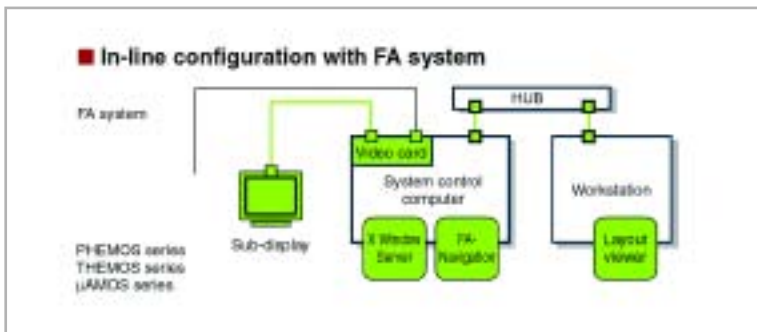

OFC/NFOEC (Anaheim Convention Center, Anaheim, CA)
Mar 27-29, 2007

Two camera versions are offered. The LN₂ cooled version offers lowest dark current and is recommended for all users who need ultimate sensitivity, while the peltier-cooled version has a slightly higher dark current and is therefore the best choice in terms of price/performance ratio.

Both camera versions are compatible with our PHEMOS 1000/2000 series of emission microscopes and can be used in combination with our NanoLens solid-immersion lens system.

Author: Hubert Ortner
Hamamatsu Photonics Germany

Features:

- Ultra-sensitive InGaAs sensor camera
- High spatial resolution of 640 pixels x 512 pixels
- Very low dark current
- Long exposure time possible

Applications:

- Semiconductor failure analysis
- Emission microscopy



HAMAMATSU

EMCCD

Electron-Multiplying CCD Technology

Our Solution for Ultrasensitive Detection of Biomolecules

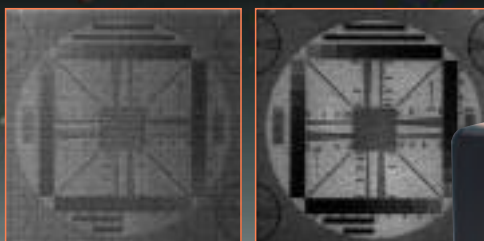

C9100 Camera

- Up to 2000 luminous gain
- Front-illuminated or back-thinned CCD
- 512 x 512 pixels or 1000 x 1000 pixels
- Absolute and stabilized cooling at -50°C
- Frame rate higher than 30 Hz in full resolution
- Very high quantum efficiency

Applications:

- High-speed fluorescence cell tomography
- Single-molecule observation at photon level
- Real-time imaging for low-light imaging
- TIRF microscope imaging
- Intravital microscopy
- Real-time confocal microscopy

Photon is our business

AEQUORIA System**The Improved Macro-Imaging System AEQUORIA**

Over 15 years ago, Hamamatsu produced the first imaging systems for macroscopic detection of bioluminescence based on photon counting cameras. Due to technical innovations of intensified and deep-cooled CCD cameras, even the faintest signals used in today's demanding applications can be detected.

The fully computer-controlled light-tight darkbox is the backbone of the AEQUORIA system and has a variety of features for added flexibility. This includes motorized heated stage and optional holes for cables and pipes, required for gas anaesthesia systems. Our side-range of cameras, from the world-wide best-seller, ORCA-AG, to the extremely sensitive ORCA II back-thinned CCD camera, can be mounted on to the darkbox for various fluorescence and luminescence applications in the wavelength range of 300 nm to 1100 nm.

The AEQUORIA system offers further flexibility with a choice of two excitation light sources, the CF1000 and the new LuxiFlux, for fluorescence applications. The CF1000 light source, now offered with a new stray-transmission light-blocking function, is a highly flexible 8-position filter wheel system to provide the user with a

wide choice of wavelengths for fluorescence excitation. The newly available LED-based LuxiFlux provides excitation illumination with superior uniformity to allow increased level of quantification. The LuxiFlux is comprised of 8 LEDs to provide excitation light at 470 nm and at 633 nm (4 LEDs for each wavelength) and an emission filter wheel for the detection of 520 nm and 665 nm.

The AEQUORIA system (camera, darkbox and light sources) is fully controlled by our WASABI software. This very intuitive software remotely controls all the features of the darkbox, including light intensity, stage height, temperature, fluorescence excitation, light sources and emission filter wheel. Therefore, WASABI software gives the system a high level of automation, allowing brightfield images, subsequent luminescence or fluorescence images to be automated for time-lapse imaging.

The modular design of the system allows great freedom of use and flexibility for various macro-imaging applications.

Author: Tanja Schüttrigkeit
Hamamatsu Photonics Germany

Features:

- Acquisition of faint luminescence and fluorescence signals with ultra-sensitive cooled CCD cameras, intensified or photon-counting cameras
- Darkbox suited for plants, microplates and small animals
- Optional fluorescence excitation
- Time-lapse recording, including control of camera, darkbox and light source
- Quantitative analysis of luminescence and fluorescence images
- Multi-ROI analysis including ROI wizard for regular sample geometries such as microplates

Applications:

- Monitoring gene expression in plants via luminescence
- Synchronous assays on microplates (luminescence and fluorescence)
- Monitoring cell-specific reactions in transgenic animals

NOTICE

We call your attention to the existence of third-party rights on certain methods for *in vivo* imaging of animals, especially EP0861093B, which is owned by the Board of Trustees of the Leland Stanford Junior University and protects the method for non-invasive detection of the integration of a trans-gene in mammals other than humans. We further refer your attention to the divisional application of the above-mentioned patent, namely EP1016419A. Use of the Hamamatsu imaging system can make use of the mentioned patent and/or application performed by the methods described therein. The purchase of a Hamamatsu imaging system does not include the right to use these patent rights. There are also patent applications of AntiCancer Incorporated, specifically EP1294906A. Use of the Hamamatsu imaging system could make use of the patent and/or application if performed in a way as eventually granted. The purchase of a Hamamatsu imaging system does not include the right to use these patents.

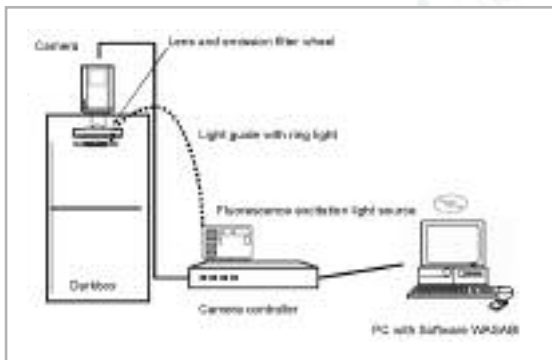

Configuration of AEQUORIA setup with fluorescence excitation system



AEQUORIA System for luminescence applications (dual-monitor setup)



APS (Denver, CO)
Mar 5-9, 2007

HAMAMATSU
Photonics

Imaging-Based Plate Reader FDSS for High-Throughput Screening

Three years ago, Hamamatsu introduced the imaging-based plate reader FDSS to the HTS community. Using unique optics and detector technology, the FDSS is a very flexible, reliable and user-friendly platform for cell-based assays.

The FDSS6000 is an image-based plate reader, compatible with both 96 and 384 formats. Measurement of calcium response is the main application for HTS, however, the design of the FDSS6000 offers greater flexibility for a wider range of applications.

With up to three dispensing heads of any format, and the possibility to use the two loading lines in the same protocol, the FDSS6000 becomes autonomous, and can be used for sophisticated assays. Reading is possible while dispensing compounds, ligands, etc., aspirated from plates, which can be manually placed into the FDSS or automatically loaded from the second line.

The FDSS6000 includes two cameras, both developed by Hamamatsu Photonics.

A high-sensitivity, cooled CCD camera is used for all fluorescence applications. It is combined with a wavelength selector (a filter wheel) for excitation and emission, allowing the use of ratiometric dyes such as Fura-2, dual dyes for multiplexing assays, or MP dye for FRET technique. To perform flash luminescence, a photon-counting camera is used with the Aequoscreen™ and steady-glow assays with the highest sensitivity.

Once calibration for all heads and plates is completed, the user just needs to select the protocol within the software and press start to run the assays. Selection from one protocol to another can be achieved simply using the software without any further technical adjustment needed.

A total of four plate stackers are available to load and receive plates, each holding twenty plates (options available). Integration with a wide range of robotic platforms can easily be achieved.

The flexibility and high throughput of the FDSS6000 makes it suitable for use in either assay development or a HTS line.

Authors:
 Walter Gräwe
 Hamamatsu Photonics Germany
 Marc Pontoizeau
 Hamamatsu Photonics France

Applications:

- Intracellular calcium assays
- Membrane-potential assays
- Ion-channel FRET assays
- Aequorin assays
- Luciferase expression
- Reading of SPA beads



Defense & Security (Orlando Marriott World Center, Orlando, FL)
 Apr 10-12, 2007

Medical Imaging Center in Hamamatsu Central Research Laboratory

At Hamamatsu Photonics, our aim is to make it possible to detect cancer and dementia at the early stages and to initiate early medical treatment—through testing that uses opto-technology. We hope that by doing this, we can contribute to realizing a society in which people can live long and healthy lives. In keeping with this goal, the Hamamatsu Medical Photonics Foundation was established in 2002, with Hamamatsu Photonics as the parent organization. It runs a clinical facility for the Hamamatsu Medical Imaging Center, which was built on the grounds of the Hamamatsu Central Research Laboratory in 2003.

Cancer is the foremost cause of death in Japan. Early detection is crucial to treating and curing the cancer. A method of image-based diagnosis called PET is gaining attention as a means of detecting the disease before it progresses.



Hamamatsu Medical Imaging Center

PET stands for “positron emission tomography.” PET works by using a small amount of a radioactive substance, in combination with sugar (FDG), to diagnose cancer. Since cancer cells divide much faster than ordinary cells, they need large amounts of sugar as a source of energy. That’s why FDG collects at high rates in cancer cells. PET is able to pinpoint where the FDG has collected, and thus where the cancer is located and how far it has spread.

The PET camera looks like an X-ray CT or MRI camera on the outside, but whereas X-ray, CT and MRI are used to obtain information about anatomical forms inside the body, PET is used to see what activity is going on in the cells.

PET is becoming a powerful tool for cancer diagnosis. It is also proving very effective in whole-body cancer screening. Since 2003, we have been running a yearly cancer screening program using PET, X-ray CT, MRI, US and blood tests, etc. to 1,217 members of Hamamatsu Photonics. The screening program detected primary cancers for 14 members in the first year (cancer incidence rate: 1.2%) and three members in the second year (0.3%).

These cancer incidence rates are higher than 0.285% of a Japanese standard group, of which age and sex are matched to the 1,217 people tested at Hamamatsu. Sixty percent of the detected cancers are at stage I — this means early detection.

In order to provide diagnostic opportunities to a greater number of people, we are promoting researches in light-based simple screening technologies that can be used prior to PET screening, so that only those people in whom cancers are suspected will go on to PET stage. PET images show a consistent pattern for Alzheimer’s disease, where specific regions of the brain show decreased FDG metabolism. It is also said this pattern can be recognized before symptoms are confirmed. We are trying to construct an FDG-PET standard pattern of asymptomatic patients based on the Hamamatsu group, which becomes very important to differentiate the Alzheimer’s pattern from normal aging. The image at right was picked from a study of a population-based cohort of 551 normal individuals in Hamamatsu and 31 patients with Alzheimer’s disease, and was selected as the 2004 Society of Nuclear Medicine (SNM) Image of the Year.



The PET camera manufactured by Hamamatsu Photonics, the SHR92000, installed at the Hamamatsu Medical Imaging Center

**SAE (Cobo Convention Center, Detroit, MI)
Apr 16-19, 2007**

New Office for Hamamatsu Photonics France

In the field of health, we are striving to create true health, a state in which people will enjoy full and satisfying physical and mental well-being as they age. At Hamamatsu we are always looking for ways to make a contribution, building on opto-technology as our foundation.

Hamamatsu Medical Photonics Foundation/ Hamamatsu Medical Imaging Center is one step towards creating new fields of industry aimed at achieving "true health".

Author: Hironobu Kodama
Hamamatsu Photonics K.K.

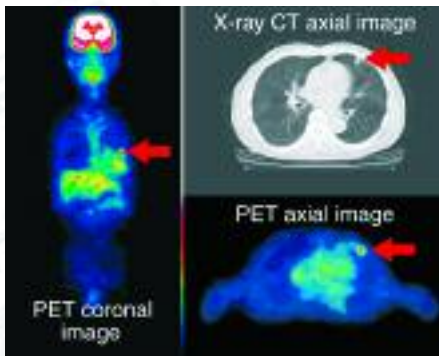

Example of early detection of lung cancer. This shows an example in which PET and X-ray CT were used to detect early-stage lung cancer measuring less than 1 cm in size (sections indicated by arrows). (Images courtesy of the Hamamatsu Medical Center, Positron Medical Center)

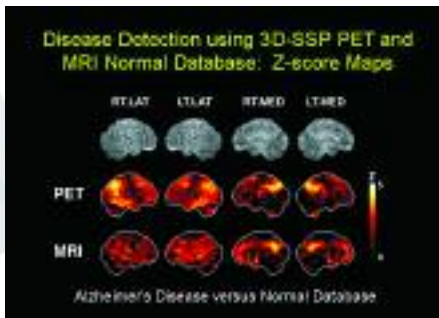

The images in the series are composites of brain scans of 31 Alzheimer's disease patients. Surface renderings on the top line provide references for right and left lateral and right and left medial views. The middle row illustrates composite FDG-PET metabolic maps, and the bottom row shows brain volumes acquired with perfusion MRI.

Hamamatsu France is pleased to announce that due to business growth they have moved to new offices.

The new offices are still within the same city of Massy (91), close to the main French research centers, such as CEA, Ecole Polytechnique, CNRS and the French Optics Valley.

The new offices are 1,350 square meters and will provide four new demonstration rooms for Systems Division products such as the Fluorescence Drug Screening System, NanoZoomer Digital Pathology (NDP) System, Emission and Thermal Microscopes and sample preparation systems. It will also be possible to demonstrate products such as Streak cameras and X-ray within the new demonstration rooms.

Customer service is key to the philosophy of Hamamatsu, and we have therefore increased the technical support department to offer our

customers an enhanced level of service for product repairs and modifications. We have also created a technical training area suitable for up to 50 people, fully equipped with the latest video and display facilities.

To enhance service and communication, all sales staff will work in an open-office area providing the ideal environment for staff to exchange information on the technologies developed by all Hamamatsu Divisions: Solid State, Electron Tube, Systems and Laser.

Secure and reliable communication with our customers and Parent Company is of paramount importance, and we have a modern computer room, with up-to-date computer systems designed specifically to provide high-level restricted access and fire protection systems for all data.

Author: Roland Lefebvre
Hamamatsu Photonics France



CLEO (Baltimore, MD)
May 8-10, 2007

ASMS (Indianapolis, IN)
Jun 3-7, 2007

Company

Last Name, First Name

Title

Address

City, State, ZIP Code

Telephone / Fax

Email

Hamamatsu is allowed to send information about their products to this email address, until further notice from the addressee. Hamamatsu will not supply this information to third parties.

MY ADDRESS HAS CHANGED. Please send all future issues of Hamamatsu *Tech News* to the address above.

The present addressee of Hamamatsu *Tech News* is NO LONGER INTERESTED in this magazine. Please FORWARD all future issues to the following recipient and address:

I want to receive Hamamatsu *Tech News* regularly. Please ADD ME to your distribution list.

Please DO NOT SEND me Hamamatsu *Tech News* in the future.

2006 Vol. 2

Please contact me

I am searching for a solution for the following application:

USA 800.524.0504
sales.hamamatsu.com

Hamamatsu Corporation

U.S. Headquarters
360 Foothill Road, Box 6910
Bridgewater, NJ 08807 U.S.A.
Telephone 908.231.0960

USA 800.524.0504
sales.hamamatsu.com

Western Office

2875 Moorpark Avenue
Suite 10
San Jose, CA 95128 U.S.A.
Telephone 408.261.2022

Systems Division, Main Office

360 Foothill Road, Box 3610
Bridgewater, NJ 08807 U.S.A.
Telephone 908.231.0960

USA 800.524.0504
sales.hamamatsu.com

Hamamatsu Photonics K.K. Headquarters

325-6, Sunayama-cho
Hamamatsu City, Shizuoka Pref.
430-8587 Japan
Telephone 81.53.452.2141

Hamamatsu European Divisions

Telephone 00.800.800.800.88
E-mail: europe@hamamatsu.com

USA 800.524.0504 sales.hamamatsu.com

Visit our website at:

<http://sales.hamamatsu.com>

USA 800.524.0504 sales.hamamatsu.com

USA 800.524.0504
sales.hamamatsu.com

USA 800.524.0504
sales.hamamatsu.com

H a m a m a t s u O f f i c e s

HAMAMATSU
Photonics

June 2006

- Semicon West** (Moscone Center, San Francisco, CA)
Jul 11-13, 2006
- AACC** (McCormick Place, Chicago, IL)
Jul 25-27, 2006
- Microscopy & Microanalysis** (Navy Pier, Chicago, IL)
Jul 30-Aug 3, 2006
- 15th Int'l Conf. Ultrafast Phenomenon** (Asilomar Conf. Grounds, Pacific Grove, CA)
Jul 31-Aug 1, 2006

August

- SPIE Annual Meeting** (San Diego Convention Center, San Diego, CA)
Aug 15-17, 2006

September

- Society for Biomolecular Screening** (Washington St. Conv. & Trade Center, Seattle, WA)
Sept 18-20, 2006

October

- Optics East** (Boston Marriott Copley Place, Boston, MA)
Oct 3-4, 2006
- FiO** (Riverside Convention Center, Rochester, NY)
Oct 10-11, 2006
- Society for Neuroscience** (Georgia World Congress Center, Atlanta, GA)
Oct 14-18, 2006
- Convergence** (Cobo Convention Center, Detroit, MI)
Oct 16-18, 2006
- ASNT** (Hilton Americas, Houston, TX)
Oct 23-25, 2006
- MDM Minneapolis** (Minneapolis Convention Center, Minneapolis, MN)
Oct 25-26, 2006
- Auto Testing Expo** (Novi Convention Center, Novi, MI)
Oct 25-27, 2006
- NSS** (Town & Country Resort, San Diego, CA)
Oct 31-Nov 2, 2006

November

- ISTFA** (Renaissance Hotel at the Arboretum Rio Grande Exhibit Hall, Austin, TX)
Nov 12-16, 2006
- MRS Fall Meeting** (Hynes Convention Center, Boston, MA)
Nov 28-30, 2006

December

- American Society for Cell Biology** (San Diego Convention Center, San Diego, CA)
Dec 9-13, 2006

January 2007

- BIOS** (San Jose Convention Center, San Jose, CA)
Jan 20-21, 2007
- Photonics West** (San Jose Convention Center, San Jose, CA)
Jan 23-25, 2007

February

- MDM West** (Anaheim Convention Center, Anaheim, CA)
Feb 13-15, 2007
- Medical Imaging** (Town and Country, San Diego, CA)
Feb 20-22, 2007

March

- APS** (Denver, CO)
Mar 5-9, 2007
- PITTCON** (McCormick Place, Chicago, IL)
Mar 11-16, 2007
- OFC/NFOEC** (Anaheim Convention Center, Anaheim, CA)
Mar 27-29, 2007

April

- Defense & Security** (Orlando Marriott World Center, Orlando, FL)
Apr 10-12, 2007
- SAE** (Cobo Convention Center, Detroit, MI)
Apr 16-19, 2007

May

- CLEO** (Baltimore, MD)
May 8-10, 2007

June

- ASMS** (Indianapolis, IN)
Jun 3-7, 2007