

EHS Standard HV Modules

8 or 4 Channels with Common Floating-GND

Operator's Manual



Contents

1. General information
2. Technical data
3. Handling
 - 3.1 Connection
 - 3.2 Limits
 - 3.3 Safety Loop
 - 3.4 Option: Single Channel INHIBIT
4. Pin assignment and connector layout
5. Order Information

Attention!

-It is not allowed to use the unit if the covers have been removed.

-We decline all responsibility for damages and injuries caused by an improper use of the module. It is highly recommended to read the manual before any kind of operation.

Note

The information in this manual is subject to change without notice. We take no responsibility for any error in the document. We reserve the right to make changes in the product design without notification to the users.

Filename EHS80x_new as of 2014-11-20

1. General information

The EHS modules of this series are Standard multichannel high voltage power supplies in 6U Eurocard format. The output voltage features a high stability, low ripple and noise and low temperature coefficient. Each single channel has an independent voltage and current control. The data for set and measure values is given in a format of Floating Point Single Precision values. The modules are equipped with 24 bit ADC and 20 bit DAC circuits.

The channels share a Common Floating-GND (C-RTN), which avoids ground loops and reduces the noise level in large systems. The Common Floating-GND is insulated from the Crate-Ground (CCG) up to ± 50 V (with a 60 V hardware limit).

With help of a jumper the channels could share a Common-GND (according to the older EHS Standard HV modules), which is connected to the internal Crate-Ground.

The HV output at the module is available as a 51 pin REDEL HV connector (up to 6 kV), SHV connectors (up to 8 kV) or SHV 10 resp. SHV 20 (KINGS) connectors (10 kV and 20 kV).

This manual covers modules with 4 or 8 channels. For output voltages up to 6 kV these modules are also available with 16 channels (see manual "EHS Standard HV Modules 16 Channels with Common-GND")

2. Technical data

	EHS 8001x ¹⁾	EHS 8005x ¹⁾	EHS 8010x ¹⁾	EHS 8020x ¹⁾	EHS 8030x ¹⁾	EHS 8040x ¹⁾	EHS 8060x ¹⁾	EHS 4080x ¹⁾	EHS 40100x ¹⁾	EHS 40200x ¹⁾
HV channels per module	8	8	8	8	8	8	8	4	4	4
Output voltage $V_{O\ nom}$ [kV]	0.1	0.5	1	2	3	4	6	8	10	20
Output current $I_{O\ nom}$ [mA]	10	15	8	4	3	2	1	1	0.5	0.4
Resolution of voltage setting ^{*)} [mV]	1	2	4	5	10	10	15	20	30	50
current setting ^{*)} [nA]	100	150	80	40	30	20	10	10	5	5
voltage measurement ^{*)} [mV]	1	2	4	5	10	10	15	20	30	50
current measurement ^{*)} [nA]	100	150	80	40	30	20	10	10	5	5
Ripple and noise [mV _{P-P}]	< 5	< 10					< 10		< 20	
	- at max. load and $ V_O > 1\% * V_{O\ nom}$ - $f > 10$ Hz									
Stability(no load/load and ΔV_{IN})	0.02%* $V_{O\ nom}$									
Sample rates [samples/s]	5, 10, 25, 50, 60, 100, 500									
Digital filter averages	1, 16, 64, 256, 512, 1024									
The resolution of measurable values depends on the settings of the sampling rate and the digital filter!										
Accuracy of voltage measurement	$\pm (0.01\% * V_O + 0.02\% * V_{O\ nom})$									
Accuracy of current measurement	$\pm (0.02\% * I_O + 0.02\% * I_{O\ nom})$									
The measurement accuracy is guaranteed in the range $1\% * V_{O\ nom} < V_O \leq V_{O\ nom}$ and for 1 year										
Voltage ramp up / down [V/s]	$1 * 10^{-6} * V_{O\ nom} \dots 0.2 * V_{O\ nom}$									
Temperature coefficient	$< \pm 50 * 10^{-6} / K$									
Hardware limits V_{max} / I_{max}	potentiometer per module (V_{max} / I_{max} is the same for all channels)									

^{*)} with standard sample rate 500/s and digital filter 64

	EHS 8001x ¹⁾	EHS 8005x ¹⁾	EHS 8010x ¹⁾	EHS 8020x ¹⁾	EHS 8030x ¹⁾	EHS 8040x ¹⁾	EHS 8060x ¹⁾	EHS 8080x ¹⁾	EHS 40100x ¹⁾	EHS 40200x ¹⁾
HV connector	51 pin REDEL (R51) / SHV (SHV)							SHV (S08)	SHV10 (S10)	SHV20 (S20)
Connector on the rear	96-pin connector according to DIN 41612									
Interface	CAN-Interface (potential free)									
Operating mode	Full module and channel control via CAN interface in EHS mode: EDCP (Enhanced Device Control Protocol) or EHQ mode: DCP (Device Control Protocol) see manual "CAN-Interface Operator's Manual"									
Module status	green LED turns on if all channels have the status "ready"									
Protection loop (I _s) potential free (2 pin Lemo-socket and REDEL SL)	5 mA < I _s < 20 mA ⇒ module on I _s < 0.5 mA ⇒ module off									
Option IDN/IUP : INHIBIT / channel	Via Sub-D-9 connector INHIBIT (TTL level)									
INHIBIT 0-7 / Channel	0	1	2	3	4	5	6	7	GND	
Sub-D-9 connector / PIN	1	2	3	4	5	6	7	8	9	
Power requirements V _{INPUT}	+ 24 V (< 4 A) and + 5 V (< 0.2 A)									
Packing	6U Euro cassette (40.64 mm wide and 220 mm deep)									
Operating temperature	0 ... +40 °C									
Storage temperature	-20 ... +60 °C									

¹⁾x=p polarity positive, ¹⁾x=n polarity negative

3. Handling

3.1 Connection

The supply voltages and the CAN interface are connected to the module via a 96-pin connector on the rear side of the module.

The module is controlled in the selected CAN operating mode (EHS or EHQ), the factory setting is "EHS mode".

3.2 Limits

The maximum output voltage for all channels (hardware voltage limit) is defined through the position of the corresponding potentiometer V_{max}.

The maximum output current for all channels (hardware current limit) is defined through the position of the corresponding potentiometer I_{max}.

The greatest possible set value for voltage and current is given by V_{max} - 2% and I_{max} - 2%, respectively.

It is possible to measure the hardware voltage and current limits at the sockets below the potentiometer. The socket voltages are proportional to the relative limits, where 2.5 V corresponds to 102 ± 2 % V_{O nom} and 102 ± 2 % I_{O nom}.

The output voltage and current are limited to the specified value. If a limit is reached or exceeded in any channel the green LED on the front panel turns off.

3.3 Safety Loop

A safety loop can be implemented via the safety loop socket (SL) on the front panel and between the SL-contacts (Pin 22 and PIN 30) at the REDEL-connector if equipped. If the safety loop is active then an output voltage in any channel is only present if the safety loop is closed and an external current in a range of 5 to 20 mA of any polarity is driven through the loop. (For modules with a REDEL-connector the other SL input must be closed.) If the safety loop is opened during the operation the output voltages are shut off without ramp and the corresponding bits in the 'ModuleStatus' (see manual "CAN-Interface Operator's Manual" 5.5.2.1 ModuleStatus) and ModuleEventStatus (5.5.2.3 ModuleEventStatus) are cancelled. After closing the loop again the ModuleEventStatus has to be reset and the channels have to be switched ON.

The loop connectors are potential free, the internal voltage drop is approx. 3 V. In the factory setup the safety loop is not active (the corresponding bits are always set). The loop can be activated by removing the internal jumper. (see manual "CAN-Interface Operator's Manual", app. B).

3.4 Option: Single Channel INHIBIT

Optionally it is possible to install an INHIBIT for each channel via a Sub-D connector on the front panel.

INHIBIT Option _IDN:

The INHIBIT pins are internally connected to the module GND with help of pull down resistors (approx. 10 k Ω). This ensures that a disconnected cable always causes an interlock. HV generation according to the settings is only possible with TTL High level on the INHIBIT pins!

INHIBIT Option _IUP:

The INHIBIT pins are internally connected to 5V with help of pull up resistors (approx. 10 k Ω). HV generation according to the settings is possible with TTL High level or not connected INHIBIT pins.

If the INHIBIT contact pin (n) is connected to the GND or a TTL-LOW potential the behavior of HV-PS in this channel depends on the following setting (5.5.2.2 ModuleControl, bit setKILena):

KILL-enable = 1: Voltage is switched off permanently without ramp. ChannelEventStatus flag 'EEINH' is set. The green LED at the front panel turns off.

KILL-enable = 0: ChannelStatus flag 'isEINH' and ChannelEventStatus flag EEINH are set. The action of the HV channel can be defined via the Monitoring group (5.5.3.3 Monitoring group, MonitorIsExternalInhibit) . The green LED at the front panel turns off.

The INHIBIT active time (LOW potential) must be at least 100 ms!

When the INHIBIT is no longer active, the INHIBIT flag must be reset before the voltage can be switched ON again (5.5.1.3 Channel event status).

4. Pin assignment and connector layout

Pin assignment 96-pin connector according to DIN 41612:

pin		pin		pin		comment
a1	+5V	b1	+5V	c1	+5V	power supply
a2	GND	b2	GND	c2	GND	
a3	+24V	b3	+24V	c3	+24V	
a5	GND	b5	GND	c5	GND	
a11	@CAN_GND	b11	@CAN_L	c11	@CAN_H	CAN bus interface, potential free
a13	/RESET	b13	/HW_RMPDWN			external control signals
a30	A4	b30	A5			address field: set module address (A0 ... A5); pin connected to GND => address bit = 0 pin open => address bit = 1
a31	A2	b31	A3	c31	GND	
a32	A0	b32	A1	c32	GND	

/RESET

active low; global reset of the module; HV generation is stopped immediately

/HW_RMPDWN

pulse form:

high – low – high with a puls-width from 1 μ s to 100 μ s

function:

ramp down all channels immediately with a ramp speed of $V_{nom}/50s$

Note: after activating this signal the ramp speed is set to $V_{nom}/50s$

51 pin REDEL HV connector

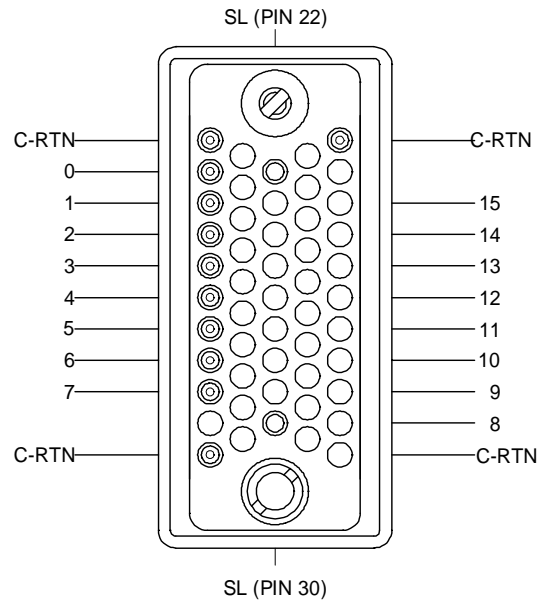

C-RTN is connected with the Modul-GND and the shield

5. Order Information

Item Code	Type	Polarity	Channels	V_{nom}	I_{nom}	HV Connector
EH040200p404S20	EHS 40200p	positive	4	20.000V	0,4mA	SHV 20 (KINGS)
EH040200n404KS20	EHS 40200n	negative	4	20.000V	0,4mA	SHV 20 (KINGS)
EH040100p504S10	EHS 40100p	positive	4	10.000V	0,5mA	SHV 10 (KINGS)
EH040100n504S10	EHS 40100n	negative	4	10.000V	0,5mA	SHV 10 (KINGS)
EH040-80p105S08	EHS 4080p	positive	4	8.000V	1mA	SHV
EH040-80n105S08	EHS 4080n	negative	4	8.000V	1mA	SHV
EH080-60p105R51	EHS 8060p	positive	8	6.000V	1mA	REDEL ¹⁾
EH080-60n105R51	EHS 8060n	negative	8	6.000V	1mA	REDEL ¹⁾
EH080-40p205R51	EHS 8040p	positive	8	4.000V	2mA	REDEL ¹⁾
EH080-40n205R51	EHS 8040n	negative	8	4.000V	2mA	REDEL ¹⁾
EH080-30p305R51	EHS 8030p	positive	8	3.000V	3mA	REDEL ¹⁾
EH080-30n305R51	EHS 8030n	negative	8	3.000V	3mA	REDEL ¹⁾
EH080-20p405R51	EHS 8020p	positive	8	2.000V	4mA	REDEL ¹⁾
EH080-20n405R51	EHS 8020n	negative	8	2.000V	4mA	REDEL ¹⁾
EH080-10p805R51	EHS 8010p	positive	8	1.000V	8mA	REDEL ¹⁾
EH080-10n805R51	EHS 8010n	negative	8	1.000V	8mA	REDEL ¹⁾
EH080-05p156R51	EHS 8005p	positive	8	500V	15mA	REDEL ¹⁾
EH080-05n156R51	EHS 8005n	negative	8	500V	15mA	REDEL ¹⁾
EH080-01p106R51	EHS 8001p	positive	8	100V	10mA	REDEL ¹⁾
EH080-01n106R51	EHS 8001n	negative	8	100V	10mA	REDEL ¹⁾

)1 Option SHV instead of R51 => Connector SHV