

# Constant-Current/ Constant-Voltage 1.4MHz Step-Up DC/DC Converter

## FEATURES

- **Accurate Input/Output Current Control:  $\pm 5\%$  Over Temperature**
- **Accurate Output Voltage Control:  $\pm 1\%$**
- Wide  $V_{IN}$  Range: 1.6V to 18V
- 1.4MHz Switching Frequency
- High Output Voltage: Up to 35V
- Low  $V_{CESAT}$  Switch: 200mV at 1A
- Available in (3mm  $\times$  3mm  $\times$  0.8mm) 10-Pin DFN and 10-Pin MSOP Packages

## APPLICATIONS

- LED Backlight Drivers
- USB Powered Boost/SEPIC Converters
- Input Current Limited Boost/SEPIC Converters
- Battery Chargers

## DESCRIPTION

The LT<sup>®</sup>1618 step-up DC/DC converter combines a traditional voltage feedback loop and a unique current feedback loop to operate as a constant-current, constant-voltage source. This fixed frequency, current mode switcher operates from a wide input voltage range of 1.6V to 18V, and the high switching frequency of 1.4MHz permits the use of tiny, low profile inductors and capacitors. The current sense voltage is set at 50mV and can be adjusted using the I<sub>ADJ</sub> pin.

Available in the 10-Pin (3mm  $\times$  3mm) Exposed Pad DFN and 10-pin MSOP packages, the LT1618 provides a complete solution for constant-current applications.

LT, LTC and LT are registered trademarks of Linear Technology Corporation.

## TYPICAL APPLICATION

**USB to 12V Boost Converter**  
(with Selectable 100mA/500mA Input Current Limit)

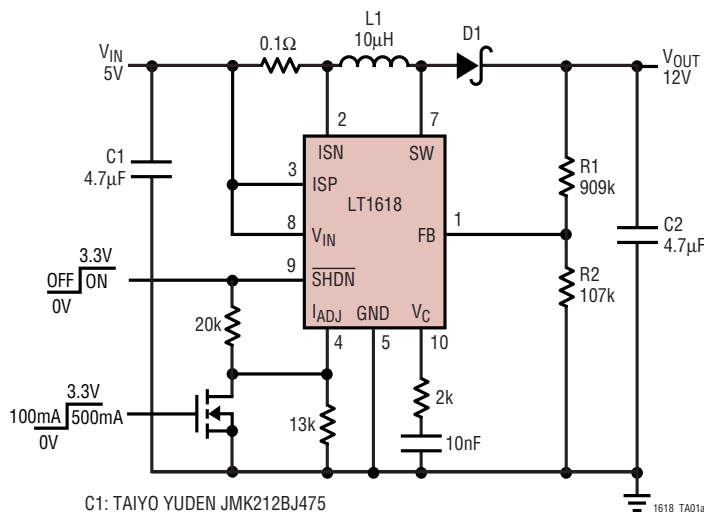

C1: TAIYO YUDEN JMK212BJ475  
 C2: TAIYO YUDEN EMK316BJ475  
 D1: ON SEMICONDUCTOR MBR0520  
 L1: SUMIDA CR43-100

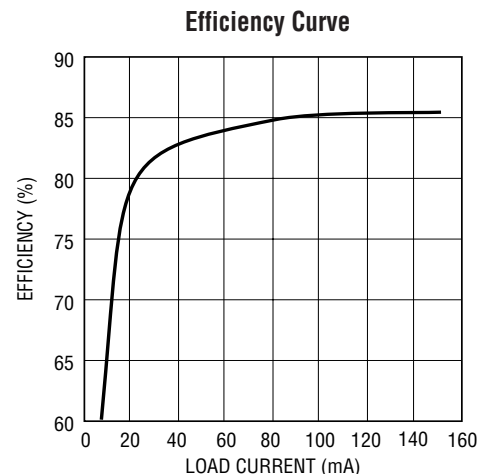

1618 TA01b

## ABSOLUTE MAXIMUM RATINGS (Note 1)

$V_{IN}$ , $\overline{SHDN}$ Voltage .....	18V	Junction Temperature .....	125°C
SW Voltage .....	36V	Operating Temperature Range (Note 2) ..	-40°C to 85°C
ISP, ISN Voltage .....	36V	Storage Temperature Range	
$I_{ADJ}$ Voltage .....	6V	MSOP .....	-65°C to 150°C
FB Voltage .....	1.5V	DFN .....	-65°C to 125°C
$V_C$ Voltage .....	1.5V	Lead Temperature (Soldering, 10 sec) (MSOP) ....	300°C

## PACKAGE/ORDER INFORMATION

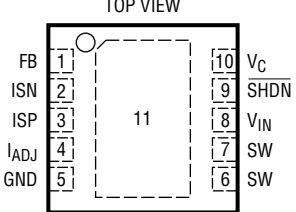
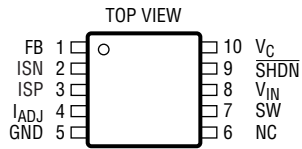
 <p>DD PACKAGE 10-LEAD (3mm × 3mm) PLASTIC DFN <math>T_{JMAX} = 125^{\circ}\text{C}</math>, <math>\theta_{JA} = 43^{\circ}\text{C/W}</math>, <math>\theta_{JC} = 3^{\circ}\text{C/W}</math> EXPOSED PAD (PIN 11) IS GND AND MUST BE SOLDERED TO PCB</p>	ORDER PART NUMBER	 <p>MS PACKAGE 10-LEAD PLASTIC MSOP <math>T_{JMAX} = 125^{\circ}\text{C}</math>, <math>\theta_{JA} = 160^{\circ}\text{C/W}</math></p>	ORDER PART NUMBER
	LT1618EDD		LT1618EMS
	DD PART MARKING		MS PART MARKING
	LAFQ		LTNH

Consult LTC marketing for parts specified with wider operating temperature ranges.

## ELECTRICAL CHARACTERISTICS

The ● denotes specifications which apply over the full operating temperature range, otherwise specifications are at  $T_A = 25^{\circ}\text{C}$ .  $V_{IN} = 1.6\text{V}$ ,  $V_{\overline{SHDN}} = 1.6\text{V}$ , unless otherwise noted.

PARAMETER	CONDITIONS	MIN	TYP	MAX	UNITS
Input Voltage		1.6		18	V
Quiescent Current	$V_{\overline{SHDN}} = 1.6\text{V}$ , Not Switching $V_{\overline{SHDN}} = 0\text{V}$		1.8 0.1	2.7 1	mA $\mu\text{A}$
Reference Voltage	Measured at FB Pin	● 1.250 1.243	1.263 1.263	1.276 1.283	V V
Reference Voltage Line Regulation	$1.6\text{V} < V_{IN} < 18\text{V}$		0.01	0.03	%/V
FB Pin Bias Current	$V_{FB} = 1.263\text{V}$ , $V_{IN} = 1.8\text{V}$	●	±2	±12	nA
Error Amplifier Voltage Gain			180		V/V
Error Amplifier Transconductance	$\Delta I_C = \pm 5\mu\text{A}$		160		$\mu\text{mho}$
Error Amplifier Sink Current	$V_{FB} = 1.35\text{V}$ , $V_C = 1\text{V}$		15		$\mu\text{A}$
Error Amplifier Source Current	$V_{FB} = 1.10\text{V}$ , $V_C = 1\text{V}$		30		$\mu\text{A}$
Current Sense Voltage (ISP, ISN)	$V_{FB} = 0\text{V}$ , $V_{IADJ} = 0\text{V}$	● 47.5	50	52.5	mV
ISP, ISN Pin Bias Currents (Note 3)	$V_{ISP} = 1.85\text{V}$ , $V_{ISN} = 1.80\text{V}$ , $V_{IADJ} = 0\text{V}$		50	80	$\mu\text{A}$
(ISP, ISN) Common Mode Minimum Voltage				1.8	V
Switching Frequency	$V_{FB} = 1\text{V}$ $V_{FB} = 0\text{V}$	1.25	1.4 550	1.6	MHz kHz
Maximum Switch Duty Cycle		● 88	92		%
Switch Current Limit		1.5	2.1	2.8	A

**ELECTRICAL CHARACTERISTICS** The ● denotes specifications which apply over the full operating temperature range, otherwise specifications are at  $T_A = 25^\circ\text{C}$ .  $V_{IN} = 1.6\text{V}$ ,  $V_{SHDN} = 1.6\text{V}$ , unless otherwise noted.

PARAMETER	CONDITIONS	MIN	TYP	MAX	UNITS
Switch $V_{CESAT}$	$I_{SW} = 1\text{A}$ , MS Package		200	260	mV
	$I_{SW} = 1\text{A}$ , DD Package		200		mV
Switch Leakage Current	Switch Off, $V_{SW} = 5\text{V}$		0.01	5	$\mu\text{A}$
SHDN Pin Current	$V_{SHDN} = 1.6\text{V}$		5	20	$\mu\text{A}$
Shutdown Threshold (SHDN Pin)				0.3	V
Start-Up Threshold (SHDN Pin)		1			V

**Note 1:** Absolute Maximum Ratings are those values beyond which the life of a device may be impaired.

**Note 2:** The LT1618 is guaranteed to meet performance specifications from  $0^\circ\text{C}$  to  $70^\circ\text{C}$ . Specifications over the  $-40^\circ\text{C}$  to  $85^\circ\text{C}$  operating

temperature range are assured by design, characterization, and correlation with statistical process controls.

**Note 3:** Bias currents flow into the ISP and ISN pins.

**TYPICAL PERFORMANCE CHARACTERISTICS**

**Switch Saturation Voltage ( $V_{CE, SAT}$ )**

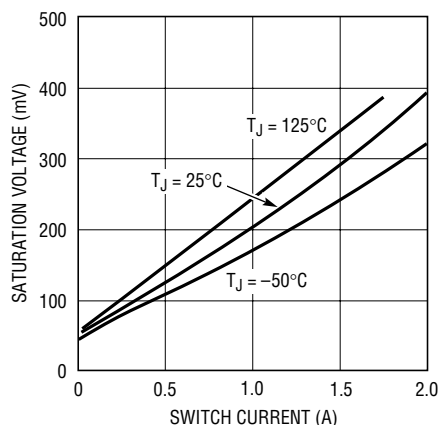

1618 G01

**FB Pin Voltage and Bias Current**

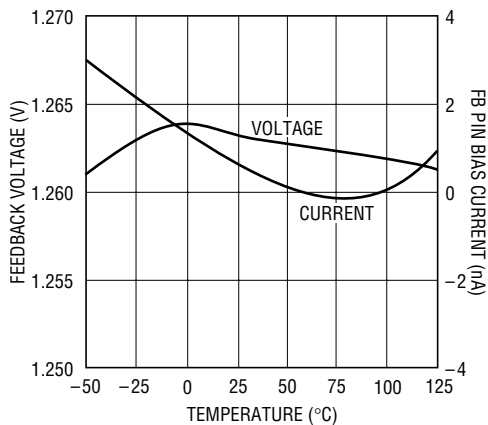

1618 G02

**Switch Current Limit**

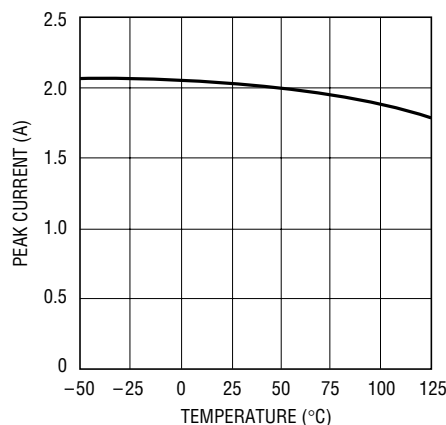

1618 G03

**Current Sense Voltage ( $I_{ADJ} \text{ Pin} = 0\text{V}$ )**

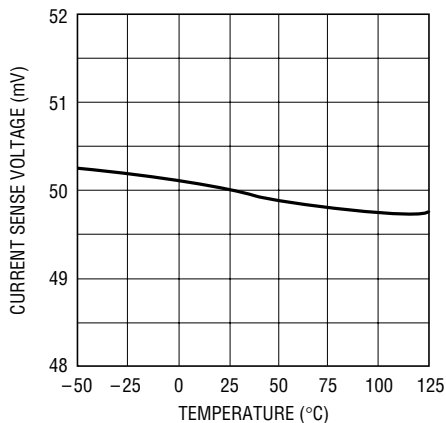

1618 G04

**Current Sense Voltage ( $V_{ISP, ISN}$ )**

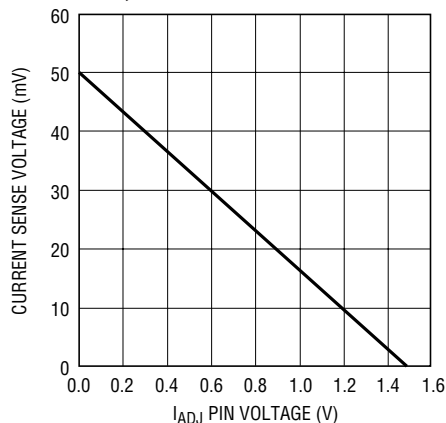

1618 G05

**Quiescent Current**

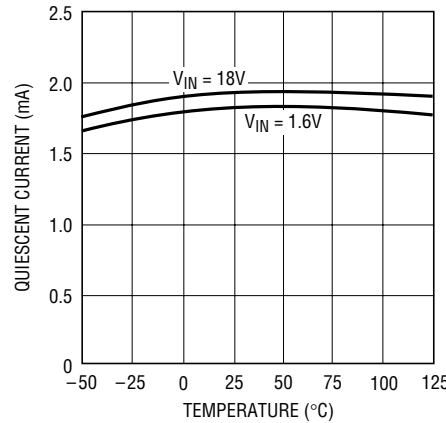

1618 G06

1618fa

## TYPICAL PERFORMANCE CHARACTERISTICS

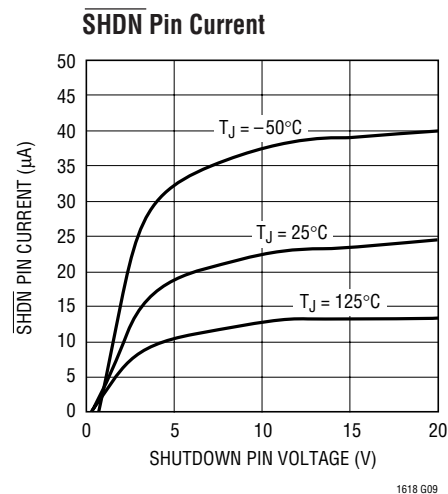
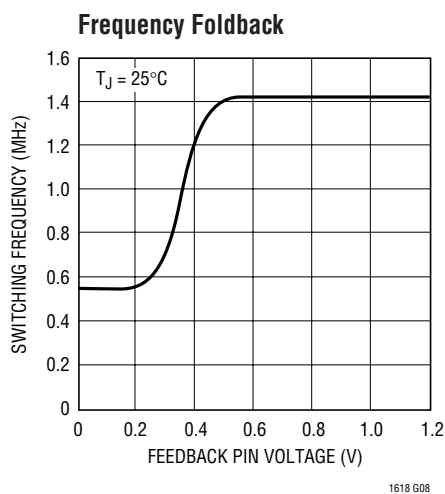
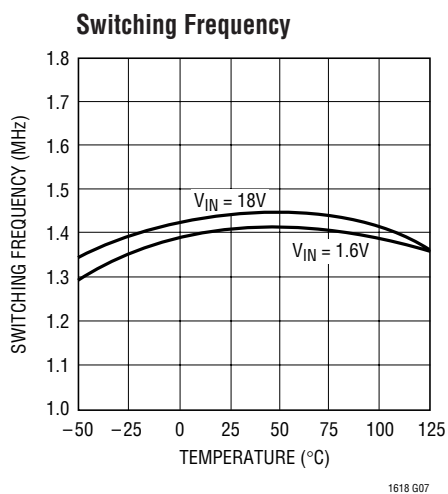

## PIN FUNCTIONS (MS/DD)

**FB (Pin 1/Pin 1):** Feedback Pin. Set the output voltage by selecting values for R1 and R2 (see Figure 1):

$$R1 = R2 \left( \frac{V_{OUT}}{1.263V} - 1 \right)$$

**ISN (Pin 2/Pin 2):** Current Sense (-) Pin. The inverting input to the current sense amplifier.

**ISP (Pin 3/Pin 3):** Current Sense (+) Pin. The noninverting input to the current sense amplifier.

**I<sub>ADJ</sub> (Pin 4/Pin 4):** Current Sense Adjust Pin. A DC voltage applied to this pin will reduce the current sense voltage. If this adjustment is not needed, tie this pin to ground.

**GND (Pin 5/Pin 5):** Ground Pin. Tie this pin directly to local ground plane.

**NC (Pin 6/NA):** No Connection for MS Package.

**SW (NA/Pin 6):** Switch Pin for DD Package. Connect this pin to Pin 7.

**SW (Pin 7/Pin 7):** Switch Pin. This is the collector of the internal NPN power switch. Minimize the metal trace area connected to this pin to minimize EMI.

**V<sub>IN</sub> (Pin 8/Pin 8):** Input Supply Pin. Bypass this pin with a capacitor to ground as close to the device as possible.

**SHDN (Pin 9/Pin 9):** Shutdown Pin. Tie this pin higher than 1V to turn on the LT1618; tie below 0.3V to turn it off.

**V<sub>C</sub> (Pin 10/Pin 10):** Compensation Pin for Error Amplifier. Connect a series RC from this pin to ground. Typical values are 2kΩ and 10nF.

**Exposed Pad (NA/Pin 11):** The Exposed Pad on the DD package is GND and must be soldered to the PCB GND for optimum thermal performance.

## BLOCK DIAGRAM

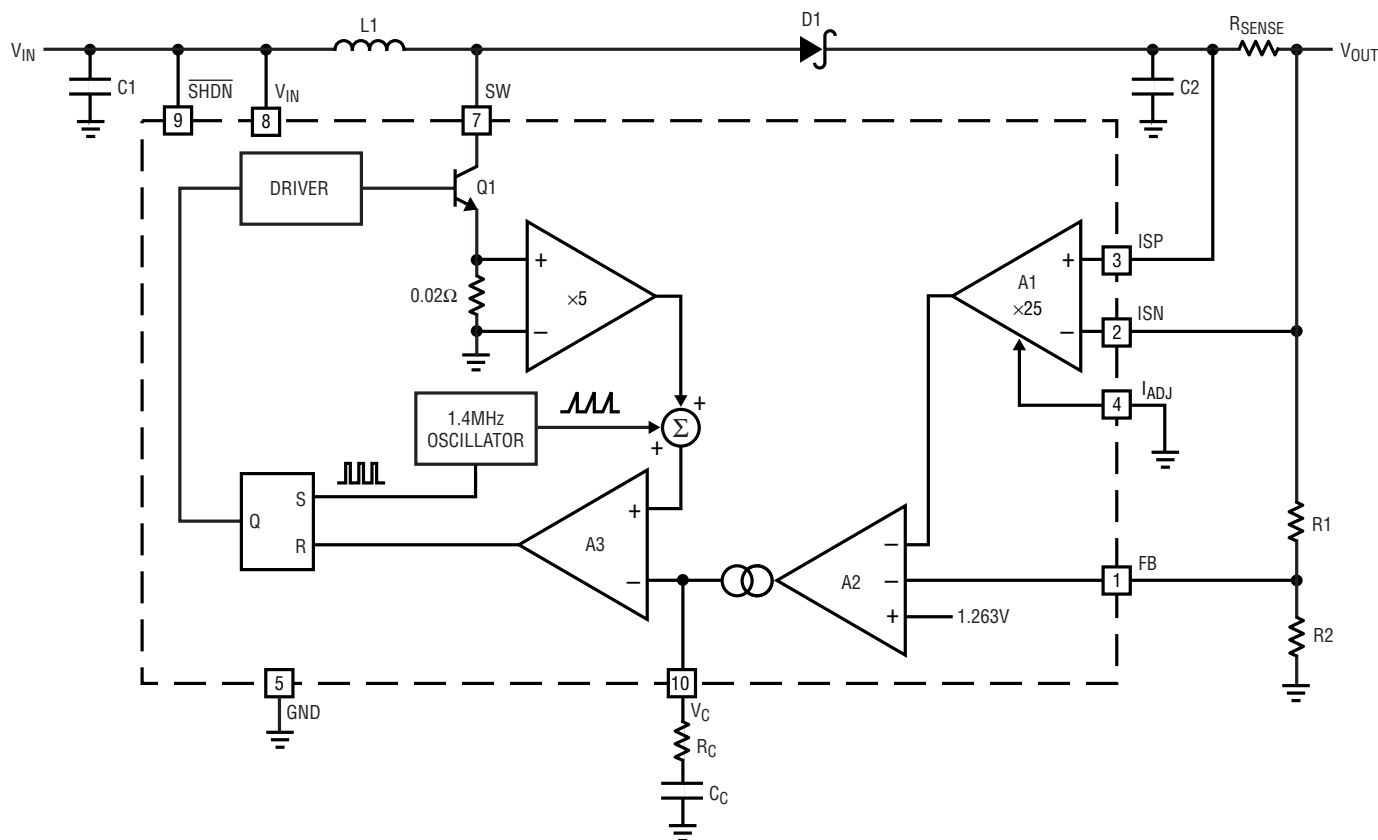

Figure 1. LT1618 Block Diagram

## OPERATION

The LT1618 uses a constant frequency, current mode control scheme to provide excellent line and load regulation. Operation can be best understood by referring to the Block Diagram in Figure 1. At the start of each oscillator cycle, the SR latch is set, turning on power switch Q1. The signal at the noninverting input of PWM comparator A3 is a scaled-down version of the switch current (summed together with a portion of the oscillator ramp). When this signal reaches the level set by the output of error amplifier A2, comparator A3 resets the latch and turns off the power switch. In this manner, A2 sets the correct peak current level to keep the output in regulation. If the error amplifier's output increases, more current is delivered to the output; if it decreases, less current is delivered. A2 has two inverting inputs, one from the voltage feedback loop, and one from the current feedback loop. Whichever inverting

input is higher takes precedence, forcing the converter into either a constant-current or a constant-voltage mode. The LT1618 is designed to transition cleanly between the two modes of operation. Current sense amplifier A1 senses the voltage between the ISP and ISN pins and provides a 25× level-shifted version to error amplifier A2. When the voltage between ISP and ISN reaches 50mV, the output of A1 provides 1.263V to one of the noninverting inputs of A2 and the converter is in constant-current mode. If the current sense voltage exceeds 50mV, the output of A1 will increase causing the output of A2 to decrease, thus reducing the amount of current delivered to the output. In this manner the current sense voltage is regulated to 50mV. Similarly, if the FB pin increases above 1.263V, the output of A2 will decrease to reduce the peak current level and regulate the output (constant-voltage mode).

1618fa

## APPLICATIONS INFORMATION

### Inductor Selection

Several inductors that work well with the LT1618 are listed in Table 1, although there are many other manufacturers and devices that can be used. Consult each manufacturer for more detailed information and for their entire selection of related parts. Many different sizes and shapes are available. Ferrite core inductors should be used to obtain the best efficiency, as core losses at 1.4MHz are much lower for ferrite cores than for the cheaper powdered-iron ones. Choose an inductor that can handle the necessary peak current without saturating, and ensure that the inductor has a low DCR (copper-wire resistance) to minimize  $I^2R$  power losses. A 4.7 $\mu$ H or 10 $\mu$ H inductor will be a good choice for many LT1618 designs.

**Table 1. Recommended Inductors**

PART	L ( $\mu$ H)	MAX (m $\Omega$ )	HEIGHT (mm)	VENDOR
CDRH5D18-4R1	4.1	57	2.0	Sumida (847) 956-0666 www.sumida.com
CDRH5D18-100	10	124	2.0	
CR43-2R2	2.2	71	3.5	
CR43-4R7	4.7	109	3.5	
CR43-100	10	182	3.5	
CR54-100	10	100	4.8	
LQH3C1R0M24	1.0	78	2.0	Murata (814) 237-1431 www.murata.com
LQH3C2R2M24	2.2	126	2.0	
LQH3C4R7M24	4.7	260	2.0	

### Capacitor Selection

Low ESR (equivalent series resistance) capacitors should be used at the output to minimize the output ripple voltage. Multilayer ceramic capacitors are an excellent choice. They have an extremely low ESR and are available in very small packages. X5R and X7R dielectrics are preferred, as these materials retain their capacitance over wider voltage and temperature ranges than other dielectrics. A 4.7 $\mu$ F to 10 $\mu$ F output capacitor is sufficient for high output current designs. Converters with lower output currents may need only a 1 $\mu$ F or 2.2 $\mu$ F output capacitor. Solid tantalum or OSCON capacitors can be used, but they will occupy more board area than a ceramic and will have a higher ESR for

the same footprint device. Always use a capacitor with a sufficient voltage rating.

Ceramic capacitors also make a good choice for the input decoupling capacitor, which should be placed as close as possible to the  $V_{IN}$  pin of the LT1618. A 1 $\mu$ F to 4.7 $\mu$ F input capacitor is sufficient for most applications. Table 2 shows a list of several ceramic capacitor manufacturers. Consult the manufacturers for detailed information on their entire selection of ceramic parts.

**Table 2. Recommended Ceramic Capacitor Manufacturers**

VENDOR	PHONE	URL
Taiyo Yuden	(408) 573-4150	www.t-yuden.com
Murata	(814) 237-1431	www.murata.com
Kemet	(408) 986-0424	www.kemet.com

### Diode Selection

Schottky diodes, with their low forward voltage drop and fast switching speed, are the ideal choice for LT1618 applications. Table 3 shows several Schottky diodes that work well with the LT1618. Many different manufacturers make equivalent parts, but make sure that the component chosen has a sufficient current rating and a voltage rating greater than the output voltage. The diode conducts current only when the power switch is turned off (typically less than half the time), so a 0.5A or 1A diode will be sufficient for most designs. The companies below also offer Schottky diodes with higher voltage and current ratings.

**Table 3. Recommended Schottky Diodes**

1A PART	0.5A PART	VENDOR	PHONE/URL
UPS120 UPS130 UPS140		Microsemi	(510) 353-0822 www.microsemi.com
MBRM120 MBRM130 MBRM140	MBR0520 MBR0530 MBR0540	ON Semiconductor	(800) 282-9855 www.onsemi.com
B120 B130 B140	B0520 B0530 B0540	Diodes, Inc	(805) 446-4800 www.diodes.com

## APPLICATIONS INFORMATION

### Setting Output Voltage

To set the output voltage, select the values of R1 and R2 (see Figure 1) according to the following equation.

$$R1 = R2 \left( \frac{V_{OUT}}{1.263} - 1 \right)$$

For current source applications, use the FB pin for over-voltage protection. Pick R1 and R2 so that the output voltage will not go too high if the load is disconnected or if the load current drops below the preset value. Typically choose R1 and R2 so that the overvoltage value will be about 20% to 30% higher than the normal output voltage (when in constant-current mode). This prevents the voltage loop from interfering with the current loop in current source applications. For battery charger applications, pick the values of R1 and R2 to give the desired end of charge voltage.

### Selecting R<sub>SENSE</sub>/Current Sense Adjustment

Use the following formula to choose the correct current sense resistor value (for constant current operation).

$$R_{SENSE} = 50\text{mV}/I_{MAX}$$

For designs needing an adjustable current level, the I<sub>ADJ</sub> pin is provided. With the I<sub>ADJ</sub> pin tied to ground, the nominal current sense voltage is 50mV (appearing between the ISP and ISN pins). Applying a positive DC voltage to the I<sub>ADJ</sub> pin will decrease the current sense voltage according to the following formula:

$$V_{ISENSE} = \frac{1.263\text{V} - (0.8)V_{IADJ}}{25}$$

For example, if 1V is applied to the I<sub>ADJ</sub> pin, the current sense voltage will be reduced to about 18mV. This adjustability allows the regulated current to be reduced without changing the current sense resistor (e.g. to adjust brightness in an LED driver or to reduce the charge current in a battery charger). If the I<sub>ADJ</sub> pin is taken above 1.6V,

the output of the error amplifier (the V<sub>C</sub> pin) will be pulled down and the LT1618 will stop switching.

A pulse width modulated (PWM) signal can also be used to adjust the current sense voltage; simply add an RC filter to convert the PWM signal into a DC voltage for the I<sub>ADJ</sub> pin. If the I<sub>ADJ</sub> pin is not used, it should be tied to ground. Do not leave the pin floating.

For applications needing only a simple one-step current sense adjustment, the circuit in Figure 2 works well. If a large value resistor (≥2MΩ) is placed between the I<sub>ADJ</sub> pin and ground, the current sense voltage will reduce to about 25mV, providing a 50% reduction in current. Do not leave the I<sub>ADJ</sub> pin open. This method gives a well-regulated current value in both states, and is controlled by a logic signal without the need for a variable PWM or DC control signal. When the NMOS transistor is on, the current sense voltage will be 50mV, when it is off, the current sense voltage will be reduced to 25mV.

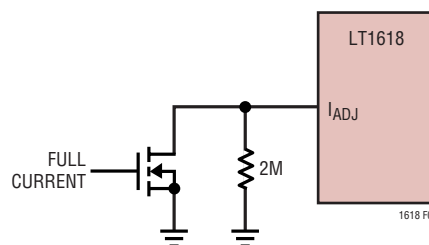

Figure 2

### Considerations When Sensing Input Current

In addition to regulating the DC output current for current-source applications, the constant-current loop of the LT1618 can also be used to provide an accurate input current limit. Boost converters cannot provide output short-circuit protection, but the surge turn-on current can be drastically reduced using the LT1618's current sense at the input. SEPICs, however, have an output that is DC-isolated from the input, so an input current limit not only helps soft-start the output but also provides excellent short-circuit protection.

## APPLICATIONS INFORMATION

When sensing input current, the sense resistor should be placed in front of the inductor (between the decoupling capacitor and the inductor) as shown in the circuits in the Typical Applications section. This will regulate the average inductor current and maintain a consistent inductor ripple current, which will, in turn, maintain a well regulated input current. Do not place the sense resistor between the input source and the input decoupling capacitor, as this may allow the inductor ripple current to vary widely (even though the average input current and the average inductor current will still be regulated). Since the inductor current is a triangular waveform (not a DC waveform like the output current) some tweaking of the compensation values ( $R_C$  and  $C_C$  on the  $V_C$  pin) may be required to ensure a clean inductor ripple current while the constant-current loop is in effect. For these applications, the constant-current loop response can usually be improved by reducing the  $R_C$  value, or by adding a capacitor (with a value of approximately  $C_C/10$ ) in parallel with the  $R_C$  and  $C_C$  compensation network.

### Frequency Compensation

The LT1618 has an external compensation pin ( $V_C$ ), which allows the loop response to be optimized for each application. An external resistor and capacitor (or sometimes just a capacitor) are placed at the  $V_C$  pin to provide a pole and a zero (or just a pole) to ensure proper loop compensation. Numerous other poles and zeroes are present in the closed

loop transfer function of a switching regulator, so the  $V_C$  pin pole and zero are positioned to provide the best loop response. A thorough analysis of the switching regulator control loop is not within the scope of this data sheet, and will not be presented here, but values of  $2k\Omega$  and  $10nF$  will be a good choice for many designs. For those wishing to optimize the compensation, use the  $2k\Omega$  and  $10nF$  as a starting point. For LED backlight applications where a pulse-width modulation (PWM) signal is used to drive the  $I_{ADJ}$  pin, the resistor is usually not included in the compensation network. This helps to provide additional filtering of the PWM signal at the output of the error amplifier (the  $V_C$  pin).

### Switch Node Considerations

To maximize efficiency, switch rise and fall times are made as short as possible. To prevent radiation and high frequency resonance problems, proper layout of the high frequency switching path is essential. Keep the output switch (SW pin), diode and output capacitor as close together as possible. Minimize the length and area of all traces connected to the switch pin, and always use a ground plane under the switching regulator to minimize interplane coupling. The high speed switching current path is shown in Figure 3. The signal path including the switch, output diode and output capacitor contains nano-second rise and fall times and should be kept as short as possible.

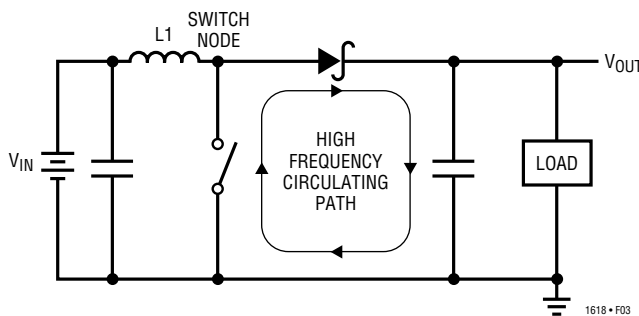
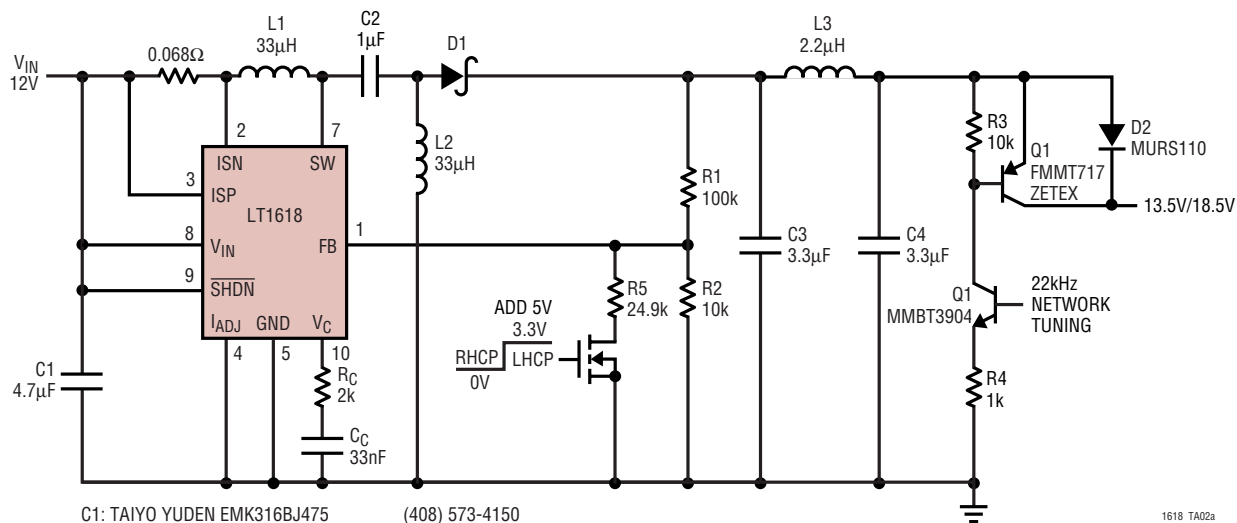

Figure 3

# TYPICAL APPLICATIONS

## 4.5W Direct Broadcast Satellite (DBS) Power Supply with Short-Circuit Protection



- C1: TAIYO YUDEN EMK316BJ475 (408) 573-4150
- C2: TAIYO YUDEN TMK316BJ105 (408) 573-4150
- C3, C4: TAIYO YUDEN TMK325BJ335 (408) 573-4150
- D1: ON SEMICONDUCTOR MBRM140 (800) 282-9855
- L1, L2: SUMIDA CR54-330 (847) 956-0666
- L3: SUMIDA CR43-2R2 (847) 956-0666

1618 TA02a

Efficiency

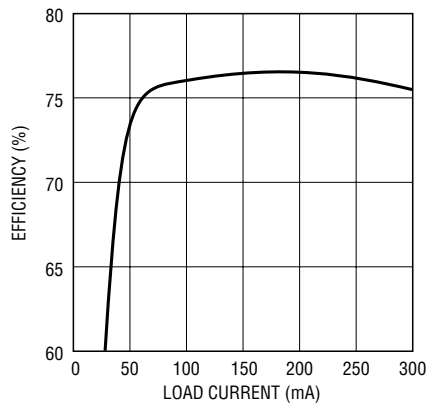

1618 TA02b

## TYPICAL APPLICATIONS

### 2-Cell White LED Driver

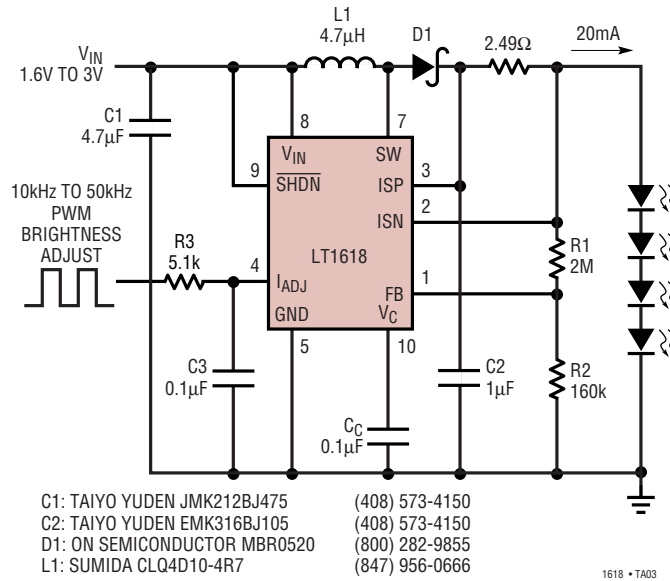

### 2-Cell Luxeon LED Driver

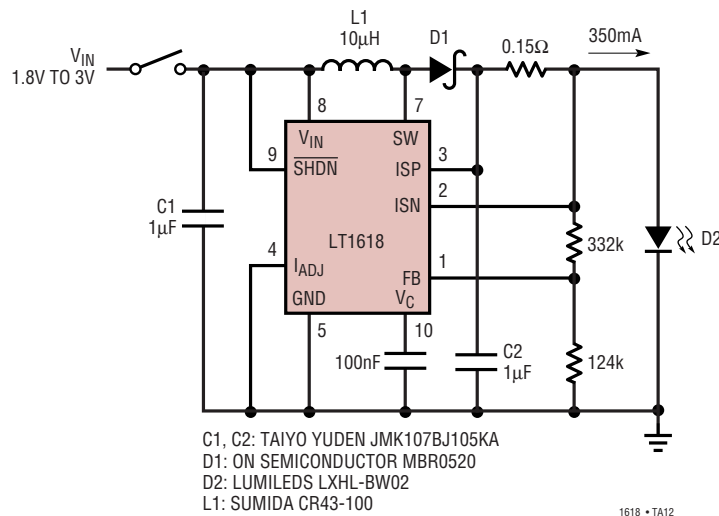

# TYPICAL APPLICATIONS

Li Ion White LED Driver

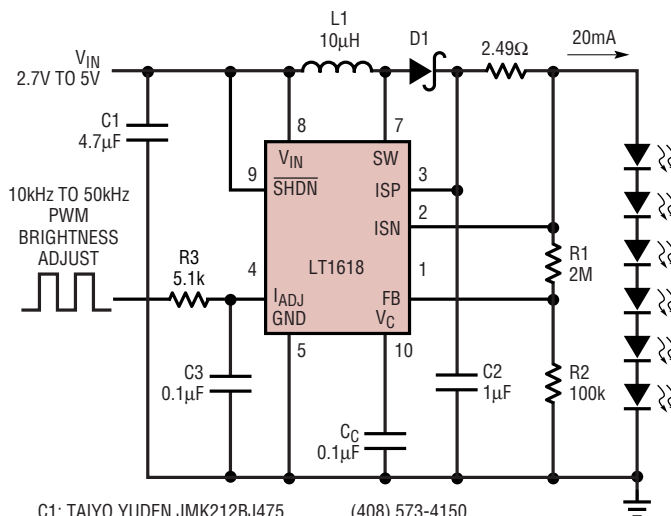

- C1: TAIYO YUDEN JMK212BJ475 (408) 573-4150
- C2: TAIYO YUDEN TMK316BJ105 (408) 573-4150
- D1: ON SEMICONDUCTOR MBR0530 (800) 282-9855
- L1: SUMIDA CLQ4D10-100 (847) 956-0666

1618 • TA04

White LED Driver for 20 LEDs

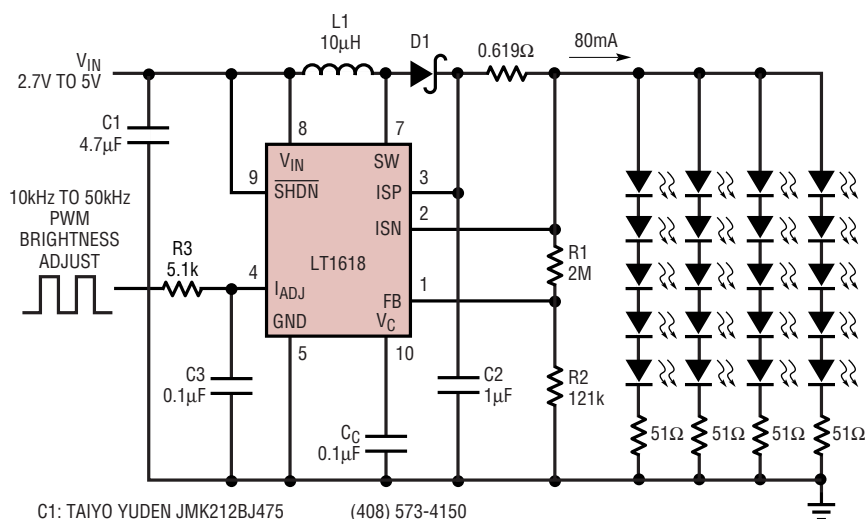

- C1: TAIYO YUDEN JMK212BJ475 (408) 573-4150
- C2: TAIYO YUDEN TMK316BJ105 (408) 573-4150
- D1: ON SEMICONDUCTOR MBR0530 (800) 282-9855
- L1: SUMIDA CR43-100 (847) 956-0666

1618 • TA05

## TYPICAL APPLICATIONS

### USB to 5V SEPIC Converter

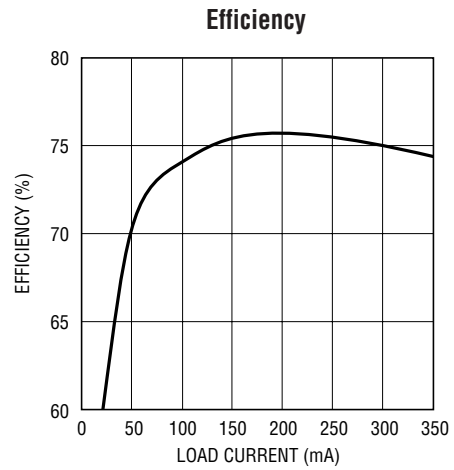
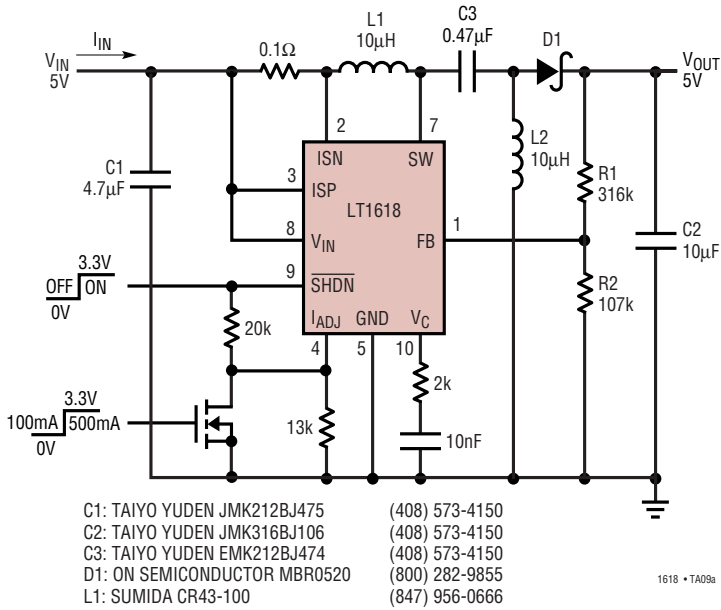

### USB SEPIC During Start-Up

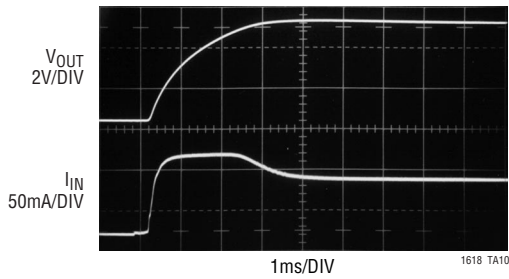

### USB SEPIC Start-Up with Output Shorted

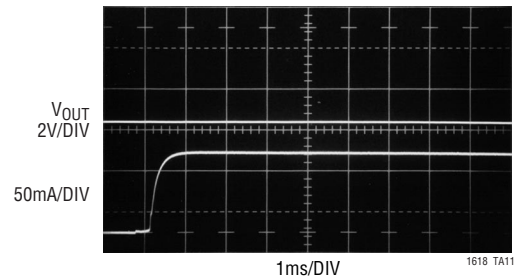

# TYPICAL APPLICATIONS

12V Boost Converter with 500mA Input Current Limit

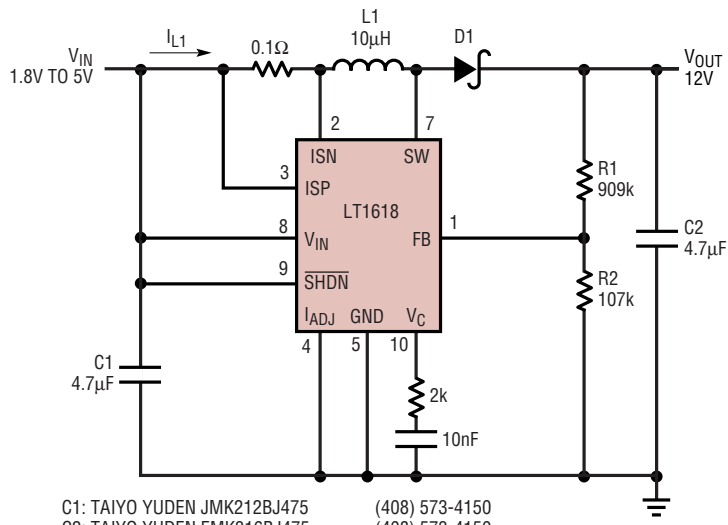

- C1: TAIYO YUDEN JMK212BJ475 (408) 573-4150
- C2: TAIYO YUDEN EMK316BJ475 (408) 573-4150
- D1: ON SEMICONDUCTOR MBR0520 (800) 282-9855
- L1: SUMIDA CR43-100 (847) 956-0666

1618 • TA06a

Efficiency

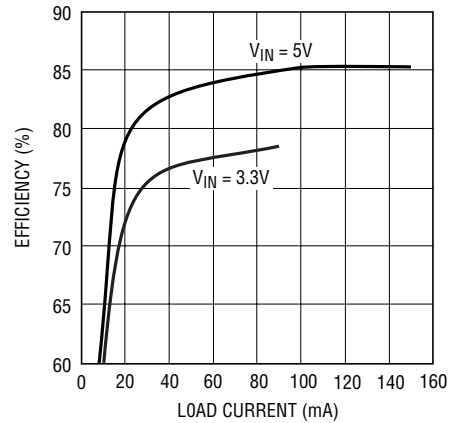

1618 TA06b

12V Boost Converter Start-Up with Input Current Limit  
(V<sub>IN</sub> = 1.8V, I<sub>LOAD</sub> = 40mA)

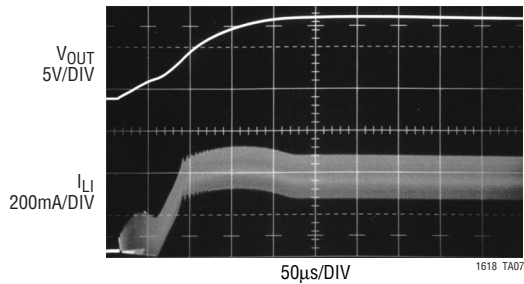

1618 TA07

12V Boost Converter Start-Up without Input Current Limit  
(V<sub>IN</sub> = 1.8V, I<sub>LOAD</sub> = 40mA)

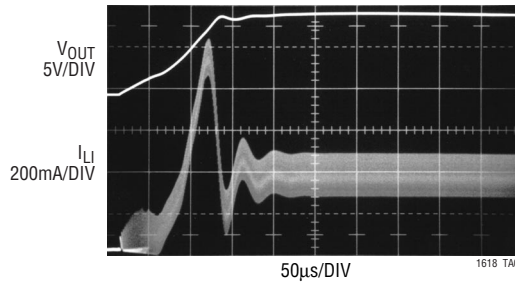

1618 TA08

**PACKAGE DESCRIPTION**

**DD Package**  
**10-Lead Plastic DFN (3mm × 3mm)**  
 (Reference LTC DWG # 05-08-1698)

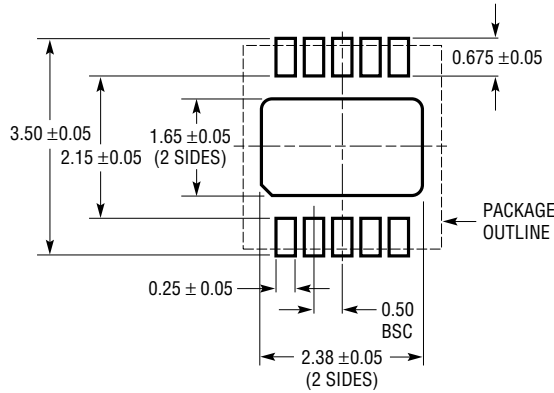

**RECOMMENDED SOLDER PAD PITCH AND DIMENSIONS**

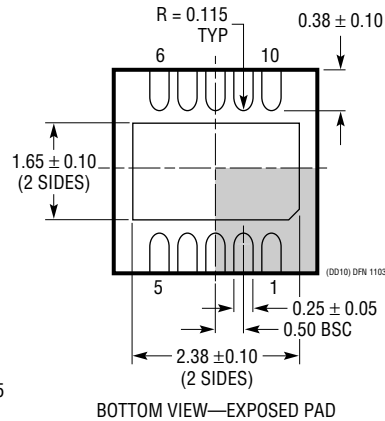
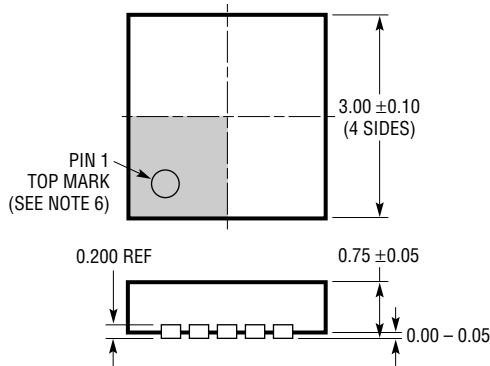

**NOTE:**

1. DRAWING TO BE MADE A JEDEC PACKAGE OUTLINE M0-229 VARIATION OF (WEED-2). CHECK THE LTC WEBSITE DATA SHEET FOR CURRENT STATUS OF VARIATION ASSIGNMENT
2. DRAWING NOT TO SCALE
3. ALL DIMENSIONS ARE IN MILLIMETERS
4. DIMENSIONS OF EXPOSED PAD ON BOTTOM OF PACKAGE DO NOT INCLUDE MOLD FLASH. MOLD FLASH, IF PRESENT, SHALL NOT EXCEED 0.15mm ON ANY SIDE
5. EXPOSED PAD SHALL BE SOLDER PLATED
6. SHADED AREA IS ONLY A REFERENCE FOR PIN 1 LOCATION ON THE TOP AND BOTTOM OF PACKAGE

# PACKAGE DESCRIPTION

**MS Package**  
**10-Lead Plastic MSOP**  
 (Reference LTC DWG # 05-08-1661)

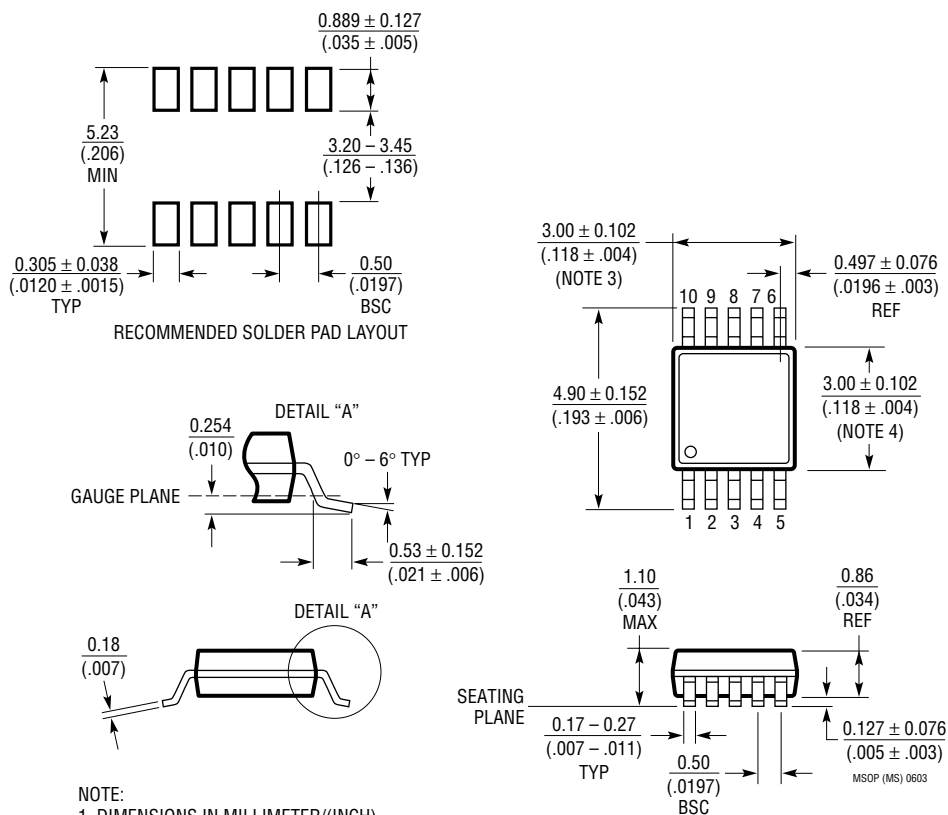

- NOTE:
1. DIMENSIONS IN MILLIMETER/(INCH)
  2. DRAWING NOT TO SCALE
  3. DIMENSION DOES NOT INCLUDE MOLD FLASH, PROTRUSIONS OR GATE BURRS.  
MOLD FLASH, PROTRUSIONS OR GATE BURRS SHALL NOT EXCEED 0.152mm (.006") PER SIDE
  4. DIMENSION DOES NOT INCLUDE INTERLEAD FLASH OR PROTRUSIONS.  
INTERLEAD FLASH OR PROTRUSIONS SHALL NOT EXCEED 0.152mm (.006") PER SIDE
  5. LEAD COPLANARITY (BOTTOM OF LEADS AFTER FORMING) SHALL BE 0.102mm (.004") MAX

## TYPICAL APPLICATIONS

### Li-Ion Buck-Boost Mode Luxeon LED Driver

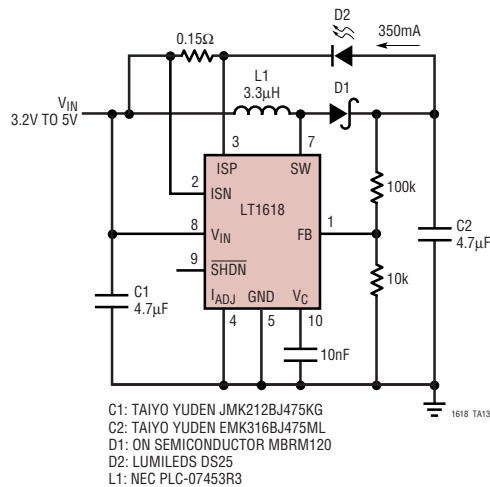

### Buck Mode Luxeon LED Driver

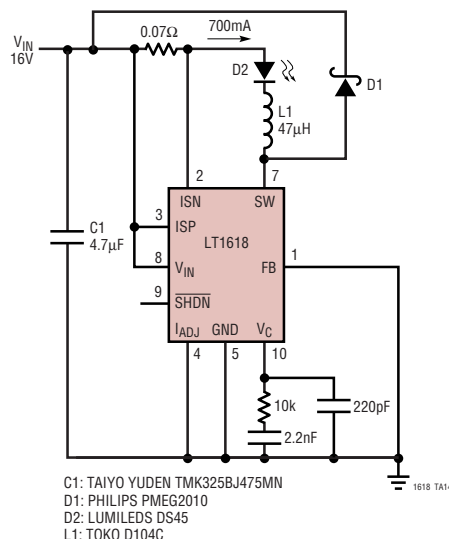

## RELATED PARTS

PART NUMBER	DESCRIPTION	COMMENTS
LT1613	550mA ( $I_{SW}$ ), 1.4MHz, High Efficiency Step-Up DC/DC Converter	$V_{IN}$ : 0.9V to 10V, $V_{OUT(MAX)}$ = 34V, $I_Q$ = 3mA, $I_{SD}$ < 1µA, ThinSOT™ Package
LT1615/LT1615-1	300mA/80mA ( $I_{SW}$ ), Constant Off-Time, High Efficiency Step-Up DC/DC Converter	$V_{IN}$ : 1.2V to 15V, $V_{OUT(MAX)}$ = 34V, $I_Q$ = 20µA, $I_{SD}$ < 1µA, ThinSOT Package
LT1930/LT1930A	1A ( $I_{SW}$ ), 1.2MHz/2.2MHz, High Efficiency Step-Up DC/DC Converter	$V_{IN}$ : 2.6V to 16V, $V_{OUT(MAX)}$ = 34V, $I_Q$ = 4.2mA/5.5mA, $I_{SD}$ < 1µA, ThinSOT Package
LT1932	Constant Current, 1.2MHz, High Efficiency White LED Boost Regulator	$V_{IN}$ : 1V to 10V, $V_{OUT(MAX)}$ = 34V, $I_Q$ = 1.2mA, $I_{SD}$ < 1µA, ThinSOT Package
LT1944/LT1944-1 (Dual)	Dual Output 350mA/100mA ( $I_{SW}$ ), Constant Off-Time, High Efficiency Step-Up DC/DC Converter	$V_{IN}$ : 1.2V to 15V, $V_{OUT(MAX)}$ = 34V, $I_Q$ = 20µA, $I_{SD}$ < 1µA, MS Package
LT1945 (Dual)	Dual Output, Pos/Neg, 350mA ( $I_{SW}$ ), Constant Off-Time, High Efficiency Step-Up DC/DC Converter	$V_{IN}$ : 1.2V to 15V, $V_{OUT(MAX)}$ = ±34V, $I_Q$ = 20µA, $I_{SD}$ < 1µA, MS Package
LT1961	1.5A ( $I_{SW}$ ), 1.25MHz, High Efficiency Step-Up DC/DC Converter	$V_{IN}$ : 3V to 25V, $V_{OUT(MAX)}$ = 35V, $I_Q$ = 0.9mA, $I_{SD}$ < 6µA, MS8E Package
LTC3401/LTC3402	1A/2A ( $I_{SW}$ ), 3MHz, Synchronous Step-Up DC/DC Converter	$V_{IN}$ : 0.5V to 5V, $V_{OUT(MAX)}$ = 6V, $I_Q$ = 38µA, $I_{SD}$ < 1µA, MS Package
LT3461/LT3461A	0.3A ( $I_{SW}$ ), 1.3MHz/3MHz, High Efficiency Step-Up DC/DC Converter with Integrated Schottky	$V_{IN}$ : 2.5V to 16V, $V_{OUT(MAX)}$ = 38V, $I_Q$ = 2.8mA, $I_{SD}$ < 1µA, SC70 and ThinSOT Packages
LT3463/LT3463A	250mA ( $I_{SW}$ ), Boost/Inverter Dual, Micropower DC/DC Converter with Integrated Schottky Diodes	$V_{IN}$ : 2.4V to 15V, $V_{OUT(MAX)}$ = ±40V, $I_Q$ = 40µA, $I_{SD}$ < 1µA, DFN Package
LT3464	0.08A ( $I_{SW}$ ), High Efficiency Step-Up DC/DC Converter with Integrated Schottky, Output Disconnect	$V_{IN}$ : 2.3V to 10V, $V_{OUT(MAX)}$ = 34V, $I_Q$ = 25µA, $I_{SD}$ < 1µA, ThinSOT Package
LT3465/LT3465A	Constant Current, 1.2MHz/2.7MHz, High Efficiency White LED Boost Regulator with Integrated Schottky Diode	$V_{IN}$ : 2.7V to 16V, $V_{OUT(MAX)}$ = 34V, $I_Q$ = 1.9mA, $I_{SD}$ < 1µA, ThinSOT Package
LT3467/LT3467A	1.1A ( $I_{SW}$ ), 1.3MHz/2.1MHz, High Efficiency Step-Up DC/DC Converter with Integrated Soft-Start	$V_{IN}$ : 2.4V to 16V, $V_{OUT(MAX)}$ = 40V, $I_Q$ = 1.2mA, $I_{SD}$ < 1µA, ThinSOT Package

ThinSOT is a trademark of Linear Technology Corporation.