

Micropower, Low Voltage, SOT-23, Dual Comparator with 400mV Reference

FEATURES

- **Low Quiescent Current: 6.5 μ A Typ at 5V**
- **Wide Supply Range: 1.4V to 18V**
- **400mV Reference \pm 2% Accuracy Over Temperature**
- Input Range Includes Ground
- Over-The-Top[®] Input Range
- Over-The-Top Open-Collector Outputs
- Internal Hysteresis: 6.5mV Typ
- Low Input Bias Current: \pm 10nA Max
- 40mA Typical Output Sink Current
- Supports Wired-AND Connections
- Choice of Input Polarities: LT6700-1/LT6700-2/LT6700-3
- Low Profile (1mm) SOT-23 (ThinSOT[™]) Package

APPLICATIONS

- Battery-Powered System Monitoring
- Threshold Detectors
- Window Comparators
- Relay Driving
- Optoisolator Driving
- Industrial Control Systems
- Handheld Instruments

DESCRIPTION

The LT[®]6700-1/LT6700-2/LT6700-3 combine two micropower, low voltage comparators with a 400mV reference in the 6-lead SOT-23 package. Operating with supplies from 1.4V up to 18V, the devices draw only 6.5 μ A typical, making them ideal for low voltage system monitoring. Hysteresis is included in the comparators, easing design requirements to insure stable output operation.

The comparators each have one input available externally, the other inputs are connected internally to the reference. The comparator outputs are open collector and the output load can be referred to any voltage up to 18V, independent of supply voltage. The output stage sinking capability is guaranteed greater than 5mA over temperature.

The three versions of the part differ by the polarity of the available comparator inputs. The LT6700-1 has one inverting input and one noninverting input, making it suitable for use as a window comparator. The LT6700-2 has two inverting inputs and the LT6700-3 has two noninverting inputs. All versions are offered in commercial, industrial and automotive temperature ranges.

LT, LTC and LT are registered trademarks of Linear Technology Corporation. Over-The-Top is a registered trademark of Linear Technology. ThinSOT is a trademark of Linear Technology Corporation.

TYPICAL APPLICATION

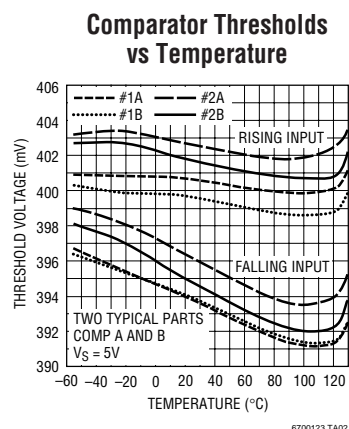
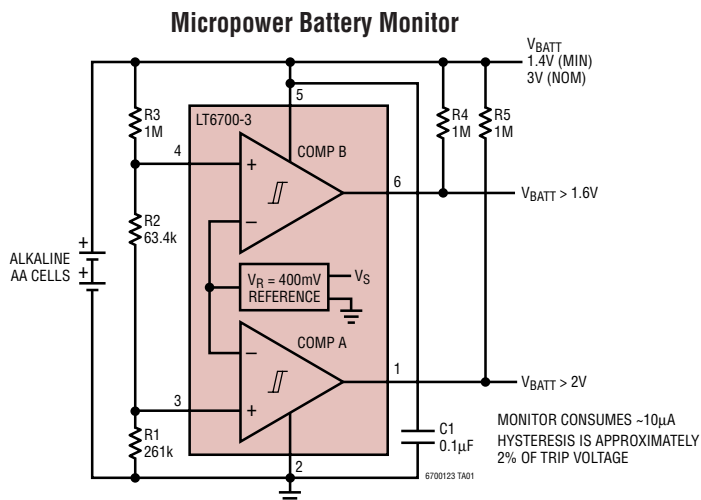

LT6700-1/LT6700-2/LT6700-3

ABSOLUTE MAXIMUM RATINGS (Note 1)

Total Supply Voltage (V_S to GND)	18.5V	Specified Temperature Range (Note 5)	
Input Voltage (+IN, -IN) (Note 3)	18.5V to (GND - 0.3V)	LT6700CS6-1/-2/-3	-40°C to 85°C
Output Voltage (OUT)	18.5V to (GND - 0.3V)	LT6700IS6-1/-2/-3	-40°C to 85°C
Output Short-Circuit Duration (Note 2)	Indefinite	LT6700HS6-1/-2/-3	-40°C to 125°C
Input Current (Note 3)	-10mA	Maximum Junction Temperature	150°C
Operating Temperature Range (Note 4)		Storage Temperature Range	-65°C to 150°C
LT6700CS6-1/-2/-3	-40°C to 85°C	Lead Temperature (Soldering, 10 sec)	300°C
LT6700IS6-1/-2/-3	-40°C to 85°C		
LT6700HS6-1/-2/-3	-40°C to 125°C		

PACKAGE/ORDER INFORMATION

ORDER PART NUMBER	S6 PART MARKING*	ORDER PART NUMBER	S6 PART MARKING*	ORDER PART NUMBER	S6 PART MARKING*
LT6700CS6-1 LT6700IS6-1 LT6700HS6-1	LTK7	LT6700CS6-2 LT6700IS6-2 LT6700HS6-2	LTADL	LT6700CS6-3 LT6700IS6-3 LT6700HS6-3	LTADM

*The temperature grades are identified by a label on the shipping container. Consult LTC Marketing for parts specified with wider operating temperature ranges.

ELECTRICAL CHARACTERISTICS $T_A = 25^\circ\text{C}$, unless otherwise specified.

SYMBOL	PARAMETER	CONDITIONS	MIN	TYP	MAX	UNITS
$V_{TH(R)}$	Rising Input Threshold Voltage	$V_S = 1.4\text{V}$, $R_L = 100\text{k}$, $V_O = 2\text{V}$ Swing	394	400	406	mV
		$V_S = 5\text{V}$	395	400	405	mV
		$V_S = 12\text{V}$	393	400	407	mV
		$V_S = 18\text{V}$	392	400	408	mV
$V_{TH(F)}$	Falling Input Threshold Voltage	$V_S = 1.4\text{V}$, $R_L = 100\text{k}$, $V_O = 2\text{V}$ Swing	386	393.5	401	mV
		$V_S = 5\text{V}$	387	393.5	400	mV
		$V_S = 12\text{V}$	385	393.5	402	mV
		$V_S = 18\text{V}$	384	393.5	403	mV
HYS	$HYS = V_{TH(R)} - V_{TH(F)}$	$V_S = 1.4\text{V}$, 5V, 12V, 18V, $R_L = 100\text{k}$, $V_O = 2\text{V}$ Swing	3.5	6.5	9.5	mV
I_B	Input Bias Current	$V_S = 1.4\text{V}$, 18V, $V_{IN} = V_S$		± 0.01	± 10	nA
		$V_S = 1.4\text{V}$, $V_{IN} = 18\text{V}$		± 0.01	± 10	nA
		$V_S = 1.4\text{V}$, 18V, $V_{IN} = 0.1\text{V}$		± 4	± 10	nA
V_{OL}	Output Low Voltage	$V_S = 1.4\text{V}$, $I_{OUT} = 0.5\text{mA}$, 10mV Input Overdrive		55	200	mV
		$V_S = 1.6\text{V}$, $I_{OUT} = 3\text{mA}$		60	200	mV
		$V_S = 5\text{V}$, $I_{OUT} = 5\text{mA}$		70	200	mV

6700123fa

ELECTRICAL CHARACTERISTICS $T_A = 25^\circ\text{C}$, unless otherwise specified.

SYMBOL	PARAMETER	CONDITIONS	MIN	TYP	MAX	UNITS
I_{OFF}	Output Leakage Current	$V_S = 1.4\text{V}, 18\text{V}, V_{\text{OUT}} = V_S, V_{\text{IN}} = 30\text{mV}$ Overdrive		0.01	0.8	μA
		$V_S = 1.4\text{V}, V_{\text{OUT}} = 18\text{V}, V_{\text{IN}} = 30\text{mV}$ Overdrive		0.01	0.8	μA
$t_{\text{PD(HL)}}$	High-to-Low Propagation Delay	$V_S = 5\text{V}, 10\text{mV}$ Input Overdrive, $R_L = 10\text{k}$, $V_{\text{OL}} = 400\text{mV}$		29		μs
$t_{\text{PD(LH)}}$	Low-to-High Propagation Delay	$V_S = 5\text{V}, 10\text{mV}$ Input Overdrive, $R_L = 10\text{k}$, $V_{\text{OH}} = 0.9 \cdot V_S$		18		μs
t_r	Output Rise Time	$V_S = 5\text{V}, 10\text{mV}$ Input Overdrive, $R_L = 10\text{k}$ $V_0 = (0.1 \text{ to } 0.9) \cdot V_S$		2.2		μs
t_f	Output Fall Time	$V_S = 5\text{V}, 10\text{mV}$ Input Overdrive, $R_L = 10\text{k}$ $V_0 = (0.1 \text{ to } 0.9) \cdot V_S$		0.22		μs
I_S	Supply Current	$V_S = 1.4\text{V}$, No Load Current		5.7	10.0	μA
		$V_S = 5\text{V}$		6.3	11.0	μA
		$V_S = 12\text{V}$		6.9	12.5	μA
		$V_S = 18\text{V}$		7.1	13.0	μA

The ● denotes the specifications which apply over the temperature range of $0^\circ\text{C} \leq T_A \leq 70^\circ\text{C}$, unless otherwise specified (Notes 4, 5).

SYMBOL	PARAMETER	CONDITIONS	MIN	TYP	MAX	UNITS
$V_{\text{TH(R)}}$	Rising Input Threshold Voltage	$V_S = 1.4\text{V}, R_L = 100\text{k}, V_0 = 2\text{V}$ Swing	●	391.0	409.0	mV
		$V_S = 5\text{V}$	●	392.5	407.5	mV
		$V_S = 12\text{V}$	●	390.0	410.0	mV
		$V_S = 18\text{V}$	●	389.0	411.0	mV
$V_{\text{TH(F)}}$	Falling Input Threshold Voltage	$V_S = 1.4\text{V}, R_L = 100\text{k}, V_0 = 2\text{V}$ Swing	●	383.5	403.5	mV
		$V_S = 5\text{V}$	●	384.5	402.5	mV
		$V_S = 12\text{V}$	●	382.5	404.5	mV
		$V_S = 18\text{V}$	●	381.5	405.5	mV
HYS	$HYS = V_{\text{TH(R)}} - V_{\text{TH(F)}}$	$V_S = 1.4\text{V}, 5\text{V}, 12\text{V}, 18\text{V}, R_L = 100\text{k}, V_0 = 2\text{V}$ Swing	●	3	11	mV
I_B	Input Bias Current	$V_S = 1.4\text{V}, 18\text{V}, V_{\text{IN}} = V_S$	●		± 15	nA
		$V_S = 1.4\text{V}, V_{\text{IN}} = 18\text{V}$	●		± 15	nA
		$V_S = 1.4\text{V}, 18\text{V}, V_{\text{IN}} = 0.1\text{V}$	●		± 15	nA
V_{OL}	Output Low Voltage	$V_S = 1.4\text{V}, I_{\text{OUT}} = 0.5\text{mA}, 10\text{mV}$ Input Overdrive	●		250	mV
		$V_S = 1.6\text{V}, I_{\text{OUT}} = 3\text{mA}$	●		250	mV
		$V_S = 5\text{V}, I_{\text{OUT}} = 5\text{mA}$	●		250	mV
I_{OFF}	Output Leakage Current	$V_S = 1.4\text{V}, 18\text{V}, V_{\text{OUT}} = V_S, V_{\text{IN}} = 30\text{mV}$ Overdrive	●		1	μA
		$V_S = 1.4\text{V}, V_{\text{OUT}} = 18\text{V}, V_{\text{IN}} = 30\text{mV}$ Overdrive	●		1	μA
I_S	Supply Current	$V_S = 1.4\text{V}$, No Load Current	●		13.0	μA
		$V_S = 5\text{V}$	●		14.0	μA
		$V_S = 12\text{V}$	●		15.5	μA
		$V_S = 18\text{V}$	●		16.0	μA

LT6700-1/LT6700-2/LT6700-3

ELECTRICAL CHARACTERISTICS

The ● denotes the specifications which apply over the temperature range of $-40^{\circ}\text{C} \leq T_A \leq 85^{\circ}\text{C}$, unless otherwise specified (Notes 4, 5).

SYMBOL	PARAMETER	CONDITIONS	MIN	TYP	MAX	UNITS
$V_{TH(R)}$	Rising Input Threshold Voltage	$V_S = 1.4\text{V}$, $R_L = 100\text{k}$, $V_O = 2\text{V}$ Swing	●	390	410	mV
			●	392	408	mV
			●	389	411	mV
			●	388	412	mV
$V_{TH(F)}$	Falling Input Threshold Voltage	$V_S = 1.4\text{V}$, $R_L = 100\text{k}$, $V_O = 2\text{V}$ Swing	●	382.5	404.5	mV
			●	383.5	403.5	mV
			●	381.5	405.5	mV
			●	380.5	406.5	mV
HYS	$HYS = V_{TH(R)} - V_{TH(F)}$	$V_S = 1.4\text{V}$, 5V, 12V, 18V, $R_L = 100\text{k}$, $V_O = 2\text{V}$ Swing	●	2	11.5	mV
I_B	Input Bias Current	$V_S = 1.4\text{V}$, 18V, $V_{IN} = V_S$	●		± 15	nA
			●		± 15	nA
			●		± 15	nA
V_{OL}	Output Low Voltage	$V_S = 1.4\text{V}$, $I_{OUT} = 0.1\text{mA}$, 10mV Input Overdrive	●		250	mV
			●		250	mV
			●		250	mV
I_{OFF}	Output Leakage Current	$V_S = 1.4\text{V}$, 18V, $V_{OUT} = V_S$, $V_{IN} = 30\text{mV}$ Overdrive	●		1	μA
			●		1	μA
I_S	Supply Current	$V_S = 1.4\text{V}$, No Load Current	●		14.0	μA
			●		15.0	μA
			●		16.5	μA
			●		17.0	μA

The ● denotes the specifications which apply over the temperature range of $-40^{\circ}\text{C} \leq T_A \leq 125^{\circ}\text{C}$, unless otherwise specified (Notes 4, 5).

SYMBOL	PARAMETER	CONDITIONS	LT6700H			UNITS
			MIN	TYP	MAX	
$V_{TH(R)}$	Rising Input Threshold Voltage	$V_S = 1.4\text{V}$, $R_L = 100\text{k}$, $V_O = 2\text{V}$ Swing	●	390	411	mV
			●	392	410	mV
			●	389	412	mV
			●	388	413	mV
$V_{TH(F)}$	Falling Input Threshold Voltage	$V_S = 1.4\text{V}$, $R_L = 100\text{k}$, $V_O = 2\text{V}$ Swing	●	381.5	405.5	mV
			●	382.5	404.5	mV
			●	380.5	406.5	mV
			●	379.5	407.5	mV
HYS	$HYS = V_{TH(R)} - V_{TH(F)}$	$V_S = 1.4\text{V}$, 5V, 12V, 18V, $R_L = 100\text{k}$, $V_O = 2\text{V}$ Swing	●	2	13.5	mV
I_B	Input Bias Current	$V_S = 1.4\text{V}$, 18V, $V_{IN} = V_S$	●		± 45	nA
			●		± 45	nA
			●		± 50	nA
V_{OL}	Output Low Voltage	$V_S = 1.4\text{V}$, $I_{OUT} = 0.1\text{mA}$, 10mV Input Overdrive	●		250	mV
			●		250	mV
			●		250	mV
I_{OFF}	Output Leakage Current	$V_S = 1.4\text{V}$, 18V, $V_{OUT} = V_S$, $V_{IN} = 30\text{mV}$ Overdrive	●		1	μA
			●		1	μA
I_S	Supply Current	$V_S = 1.4\text{V}$, No Load Current	●		16.0	μA
			●		17.0	μA
			●		18.5	μA
			●		19.0	μA

ELECTRICAL CHARACTERISTICS

Note 1: Absolute Maximum Ratings are those beyond which the life of the device may be impaired.

Note 2: A heat sink may be required to keep the junction temperature below the absolute maximum rating when the output is shorted indefinitely.

Note 3: The inputs are protected by ESD diodes to the ground. If the input voltage exceeds $-0.3V$ below ground, the input current should be limited to less than 10mA.

Note 4: The LT6700CS6-1/-2/-3 and LT6700IS6-1/-2/-3 are guaranteed functional over the operating temperature range of $-40^{\circ}C$ to $85^{\circ}C$. The

LT6700HS6-1/-2/-3 are guaranteed functional over the operating temperature range of $-40^{\circ}C$ to $125^{\circ}C$.

Note 5: The LT6700CS6-1/-2/-3 are guaranteed to meet the specified performance from $0^{\circ}C$ to $70^{\circ}C$. The LT6700CS6-1/-2/-3 are designed, characterized and expected to meet specified performance from $-40^{\circ}C$ to $85^{\circ}C$ but are not tested or QA sampled at these temperatures. The LT6700IS6-1/-2/-3 are guaranteed to meet specified performance from $-40^{\circ}C$ to $85^{\circ}C$. The LT6700HS6-1/-2/-3 are guaranteed to meet specified performance from $-40^{\circ}C$ to $125^{\circ}C$.

PIN FUNCTIONS

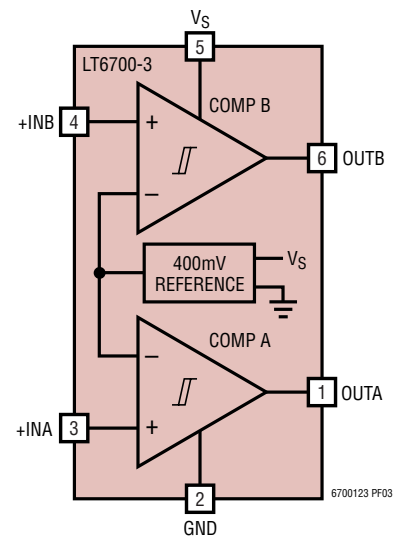
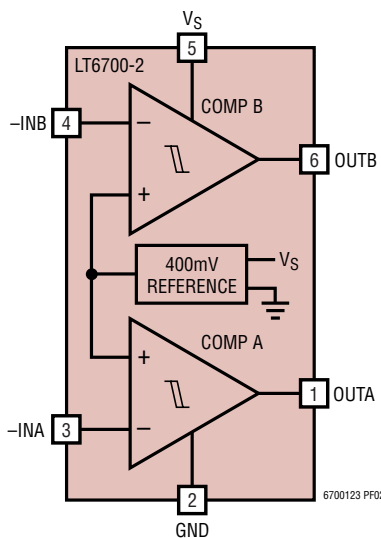
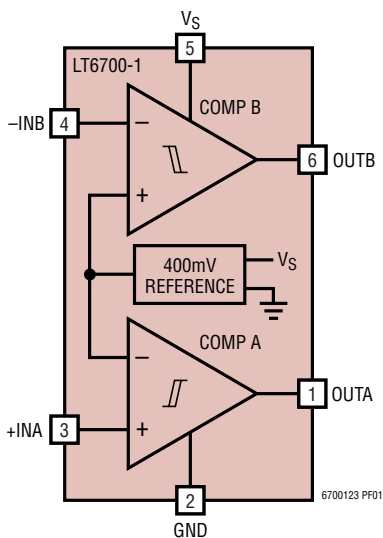

OUTA (Pin 1): Open-Collector Output of Comparator Section A. This pin provides drive for up to 40mA of load current. Off-state voltage may be as high as 18V above GND (Pin 2), regardless of V_S used.

GND (Pin 2): Ground. This pin is also the low side return of the internal 400mV reference.

INA (Pin 3): External Input for Comparator Section A. The voltage on this pin can range from $-0.3V$ to 18V with respect to GND (Pin 2) regardless of V_S used. The input is noninverting for the LT6700-1 and LT6700-3, and inverting for the LT6700-2. The other section A comparator input is internally connected to the 400mV reference.

INB (Pin 4): External Input for Comparator Section B. The voltage on this pin can range from $-0.3V$ to 18V with respect to GND (Pin 2) regardless of V_S used. The input is noninverting for the LT6700-3, and inverting for the LT6700-1 and LT6700-2. The other section B comparator input is internally connected to the 400mV reference.

V_S (Pin 5): Comparator Core Supply Voltage. The parts are characterized for operation with $1.4V \leq V_S \leq 18V$ with respect to GND (Pin 2).

OUTB (Pin 6): Open-Collector Output of Comparator Section B. This pin provides drive for up to 40mA of load current. Off-state voltage may be as high as 18V above GND (Pin 2), regardless of V_S used.

TYPICAL PERFORMANCE CHARACTERISTICS

Distribution of Rising Input Threshold Voltage

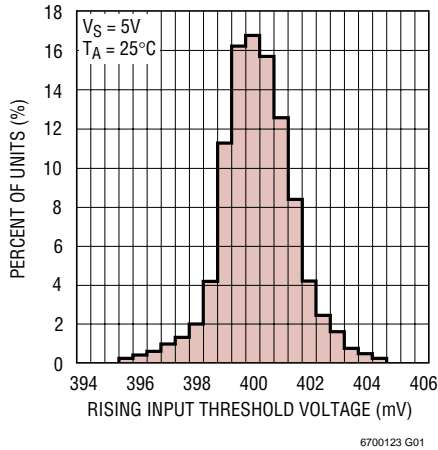

Distribution of Falling Input Threshold Voltage

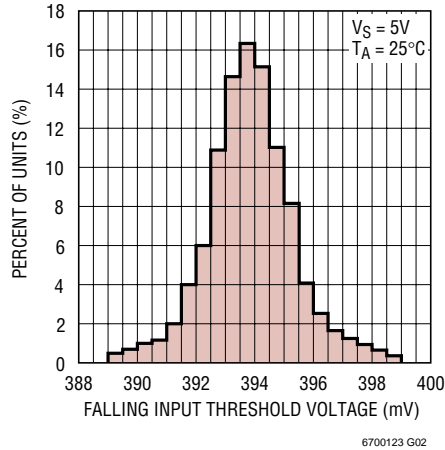

Distribution of Hysteresis

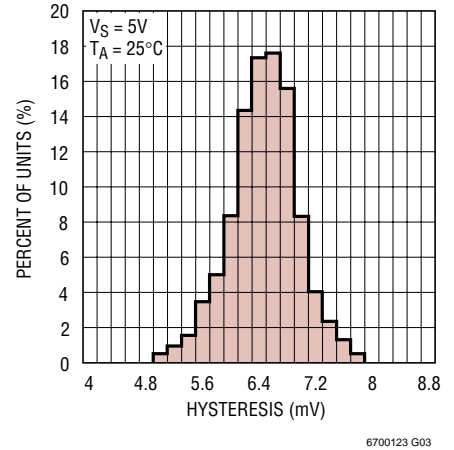

Rising Input Threshold Voltage vs Temperature

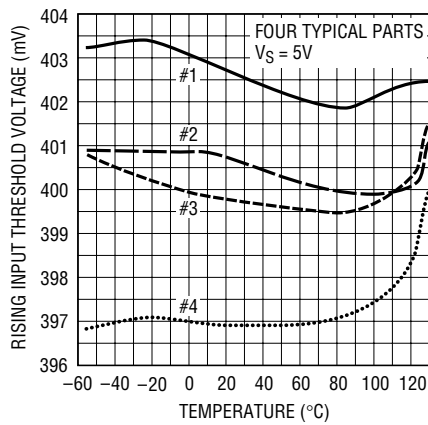

Rising Input Threshold Voltage vs Temperature

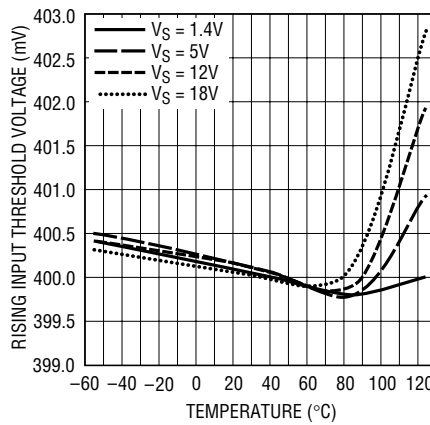

Rising Input Threshold Voltage vs Supply Voltage

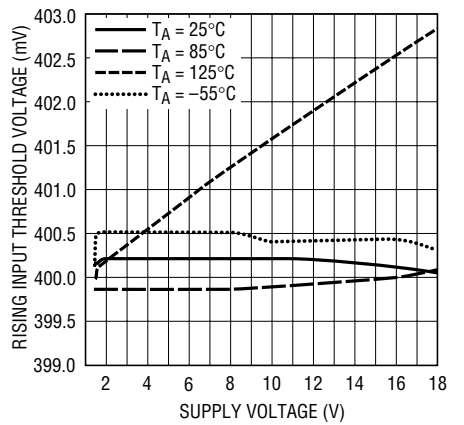

Hysteresis vs Temperature

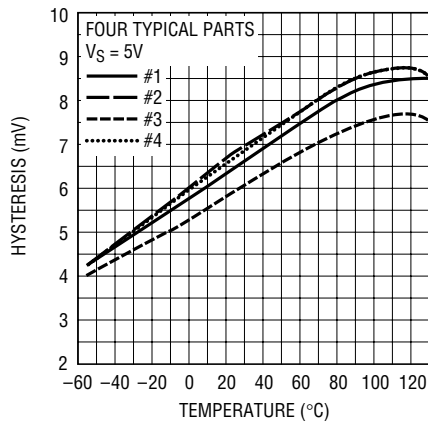

Hysteresis vs Temperature

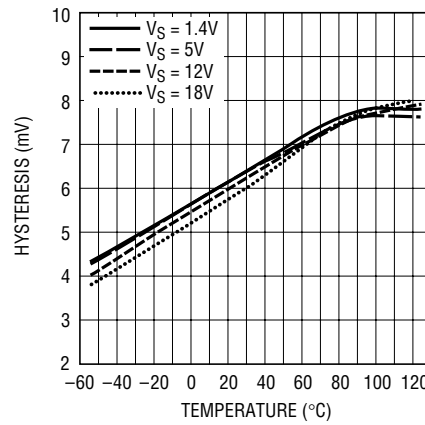

Hysteresis vs Supply Voltage

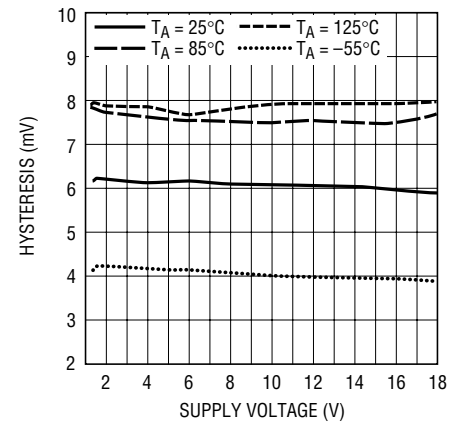

TYPICAL PERFORMANCE CHARACTERISTICS

Minimum Supply Voltage

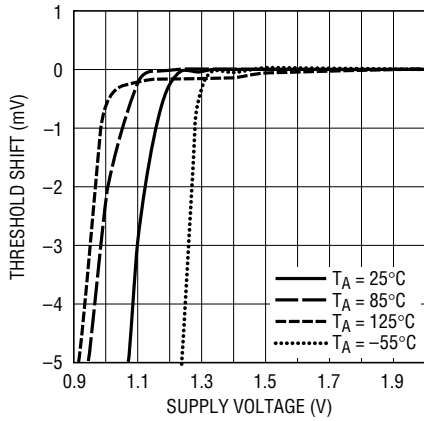

6700123 G10

Quiescent Supply Current vs Supply Voltage

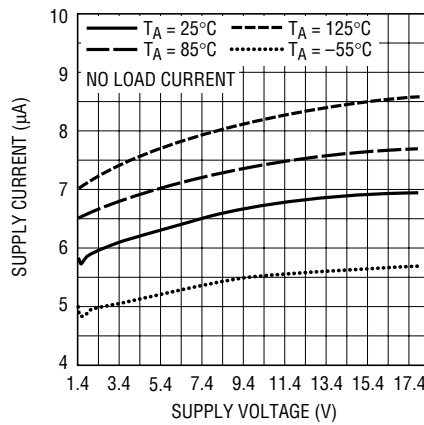

6700123 G11

Start-Up Supply Current

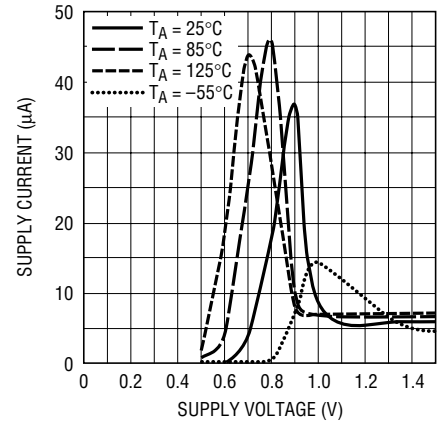

6700123 G12

Supply Current vs Output Sink Current

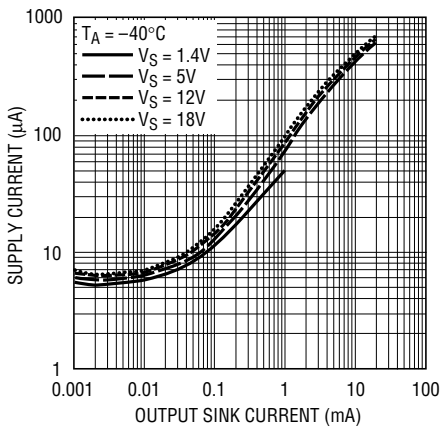

6700123 G13

Supply Current vs Output Sink Current

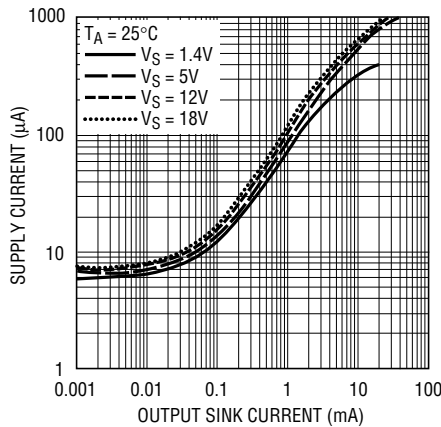

6700123 G14

Supply Current vs Output Sink Current

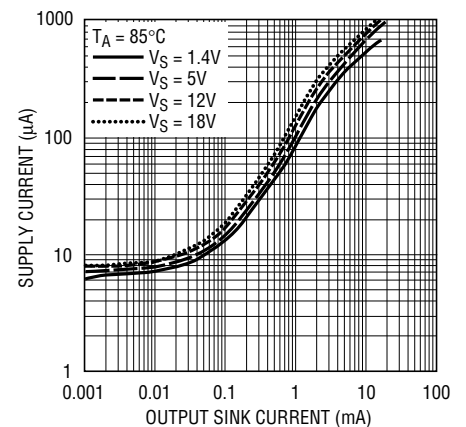

6700123 G15

Below Ground Input Bias Current

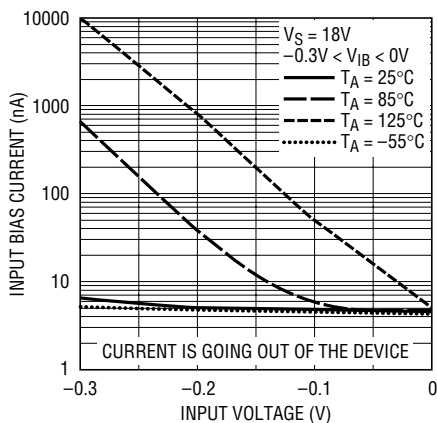

6700123 G16

Low Level Input Bias Current

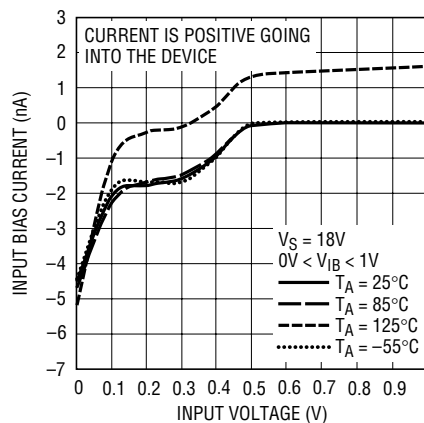

6700123 G17

High Level Input Bias Current

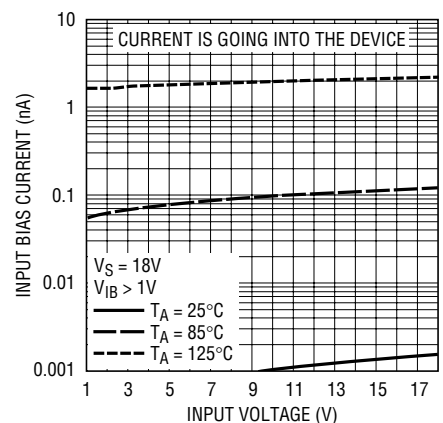

6700123 G18

TYPICAL PERFORMANCE CHARACTERISTICS

Output Saturation Voltage vs Output Sink Current

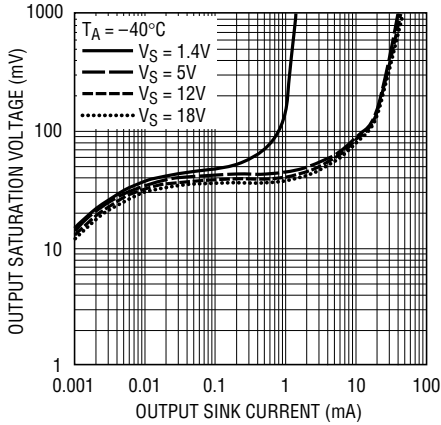

6700123 G19

Output Saturation Voltage vs Output Sink Current

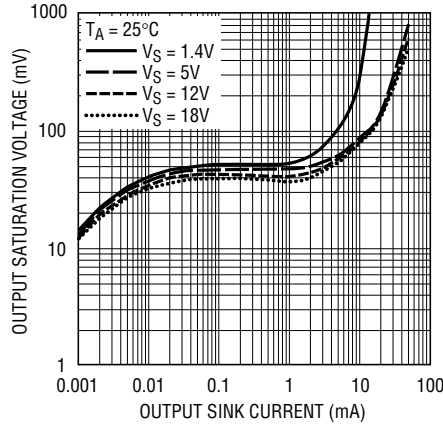

6700123 G20

Output Saturation Voltage vs Output Sink Current

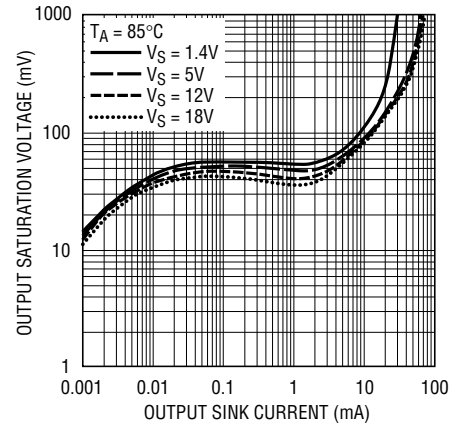

6700123 G21

Output Short-Circuit Current

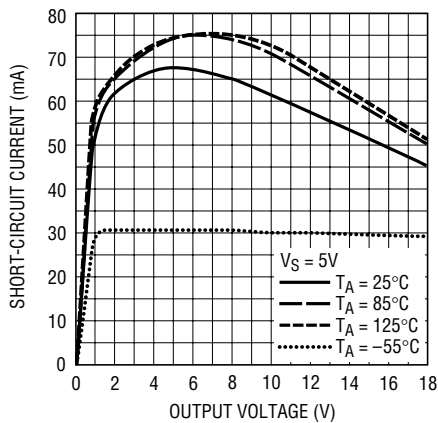

6700123 G22

Output Short-Circuit Current

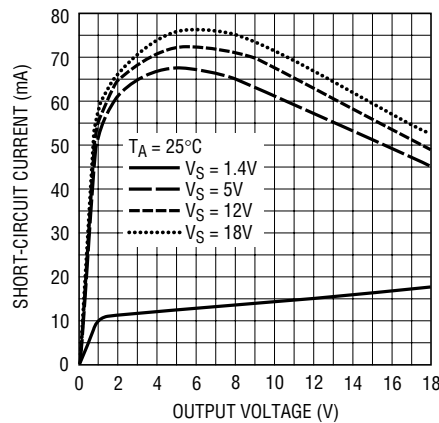

6700123 G23

Output Leakage Current

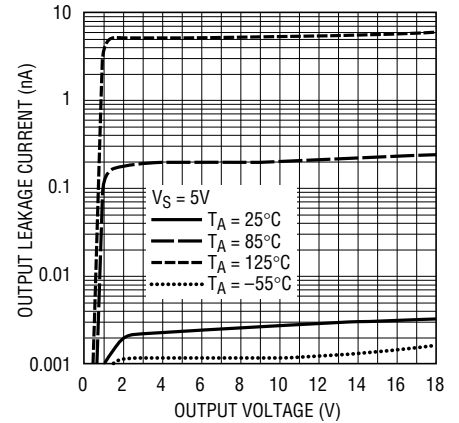

6700123 G24

Propagation Delay vs Input Overdrive

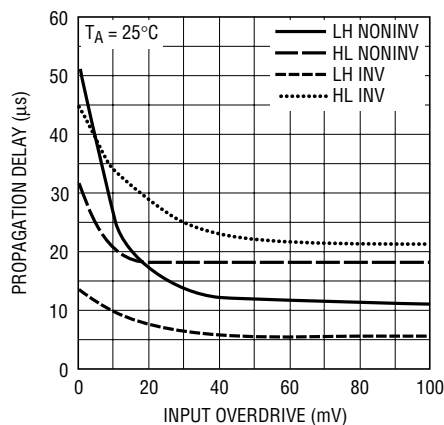

6700123 G25

Rise and Fall Times vs Output Pull-Up Resistor

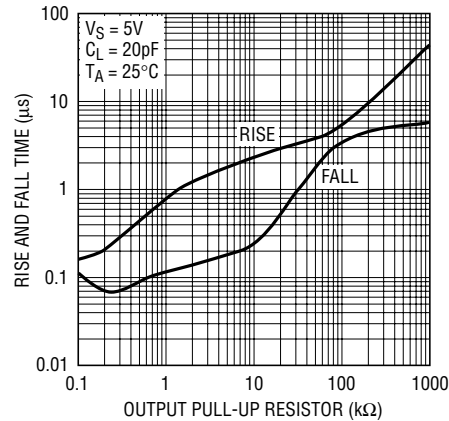

6700123 G26

Noninverting and Inverting Comparators' Propagation Delay

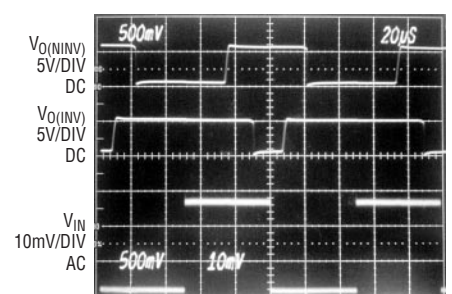

$V_S = 5V$ 20µs/DIV 6700123 G27
 $T_A = 25^\circ C$
 $R_{LOAD} = 10k$ CONNECTED TO V_S
 $V_{IN(OVERDRIVE)} = 10mV$ OVER THE INPUT VOLTAGE THRESHOLDS

APPLICATIONS INFORMATION

The LT6700-1/LT6700-2/LT6700-3 devices are a family of dual micropower comparators with a built-in 400mV reference. Features include wide supply voltage range (1.4V to 18V), Over-The-Top input and output range, 2% accurate rising input threshold voltage and 6.5mV typical built-in hysteresis. The comparator's open-collector outputs can sink up to 40mA typical.

Internal Reference

Each of the comparator sections has one input available externally, with the three versions of the part differing by the polarity of those available inputs (i.e., inverting or noninverting). The other comparator inputs are connected internally to the 400mV reference. The rising input threshold voltage of the comparators is designed to be equal to that of the reference (i.e., $\approx 400\text{mV}$). The reference voltage is established with respect to the device GND connection.

Hysteresis

Each comparator has built-in 6.5mV (typical) hysteresis to simplify designs, insure stable operation in the presence of noise at the inputs, and to reject supply rail noise that might be induced by state change load transients. The hysteresis is designed such that the falling input threshold voltage is nominally 393.5mV. External positive feedback circuitry can be employed with noninverting comparator inputs to increase effective hysteresis if desired, but such circuitry will provide an apparent effect on both the rising and falling input thresholds (the actual internal thresholds remain unaffected).

Comparator Inputs

A comparator input can swing from ground to 18V, regardless of the supply voltage used. The typical input current for inputs well above threshold (i.e., $>800\text{mV}$) is a few pA leaking into an input. With decreasing input voltage, a small bias current begins to be drawn out of the input, reaching a few nA when at ground potential. The input may be forced 100mV below ground without causing an improper output, though some additional bias current will begin to flow from the parasitic ESD input protection diode. Inputs driven further negative than 100mV below ground will not cause comparator malfunction or damage

(provided the current is limited to 10mA), but the accuracy of the reference cannot be guaranteed, in which case the output state of the alternate comparator may be effected.

Comparator Outputs

The comparator outputs are open collector and capable of sinking 40mA typical. Load currents are directed out the GND pin of the part. The output off-state voltage may range between -0.3V and 18V with respect to ground, regardless of the supply voltage used. As with any open-collector device, the outputs may be tied together to implement wire-AND logic functions.

Power Supplies

The comparator family core circuitry operates from a single 1.4V to 18V supply. A minimum 0.1 μF bypass capacitor is required between the V_S pin and GND. When an output load is connected to the supply rail near the part and the output is sinking more than 5mA, a 1 μF bypass capacitor is recommended. In instances where the supply is relatively "soft" (such as with small batteries) and susceptible to load steps, an additional 47 Ω series decoupling resistor can further improve isolation of supply transients from the V_S pin.

Flexible Window Comparator

Using the LT6700-1 as shown in the circuits of Figure 1, the wire-AND configuration permits high accuracy window functions to be implemented with a simple 3-resistor voltage divider network. The section A comparator provides the V_L trip-point and the section B comparator provides the V_H trip-point, with the built-in hysteresis providing about 1.7% recovery level at each trip point to prevent output chatter.

For designs that are to be optimized to detect *departure* from a window limit, the nominal resistor divider values are selected as follows (refer to the resistor designators shown on the first circuit of Figure 1):

$$R1 \leq 400\text{k} \text{ (this sets the divider current } \gg I_B \text{ of inputs)}$$

$$R2 = R1 \cdot (0.98 \cdot V_H/V_L - 1)$$

$$R3 = R1 \cdot (2.5 \cdot V_H - 0.98 \cdot V_H/V_L)$$

APPLICATIONS INFORMATION

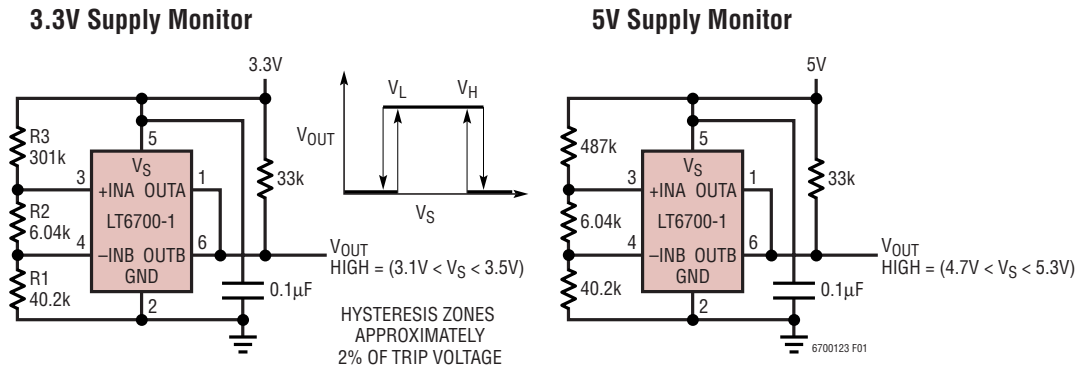

Figure 1. Simple Window Comparator

To create window functions optimized for detecting *entry* into a window (i.e. where the output is to indicate a “coming into spec” condition, as with the examples in Figure 1), the nominal resistor values are selected as follows:

$$R1 \leq 400k \text{ (this sets the divider current } \gg I_B \text{ of inputs)}$$

$$R2 = R1 \cdot (1.02 \cdot V_H/V_L - 1)$$

$$R3 = R1 \cdot (2.54 \cdot V_H - 1.02 \cdot V_H/V_L)$$

The worst-case variance of the trip-points is related to the specified threshold limits of the LT6700 device and the basic tolerance of divider resistors used. For resistor tolerance R_{TOL} (e.g. 0.01 for 1%), the worst-case trip-point voltage (either V_H or V_L) deviations can be predicted as follows (italicized values are taken from the datasheet, expressed in volts):

$$\text{Max dev } V_{TRIP\uparrow} = \pm V_{TRIPnom} \cdot \{2 \cdot R_{TOL} \cdot [(V_{TRIPnom} - 0.4) / V_{TRIPnom}] + 1.25 \cdot (V_{TH(R)max} - V_{TH(R)min})\}$$

$$\text{Max dev } V_{TRIP\downarrow} = \pm V_{TRIPnom} \cdot \{2 \cdot R_{TOL} \cdot [(V_{TRIPnom} - 0.39) / V_{TRIPnom}] + 1.27 \cdot (V_{TH(F)max} - V_{TH(F)min})\}$$

Generating an External Reference Signal

In some applications, it would be advantageous to have access to a signal that is directly related to the internal 400mV reference, even though the reference itself is not available externally. This can be accomplished to a reasonable degree by using an inverting comparator section as a “bang-bang” servo, establishing a nominal voltage, on an integration capacitor, that is scaled to the reference. This method is used in Figure 2, where the reference level has

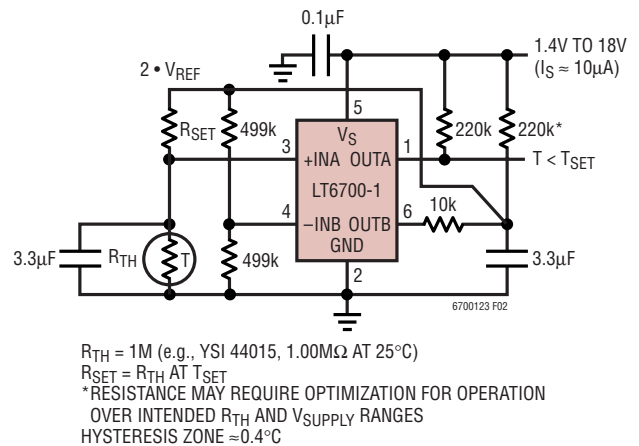

Figure 2. Micropower Thermostat/Temperature Alarm

been doubled to drive a resistor bridge. The section B output cycles on and off to swing the section B input between its hysteresis trip points as the load capacitor charges and discharges in a shallow, controlled fashion. The multiplied reference signal also contains ripple that is the hysteresis multiplied by the same factor, so additional filtering is performed at the sense node of the bridge to prevent comparator chatter in the section A comparator, which is performing the actual conditional decision for the circuit.

Instrumentation Grade Pulse Width Modulator (PWM)

Comparators with hysteresis are frequently employed to make simple oscillator structures, and the LT6700 lends itself nicely to forming a charge-balancing PWM function. The circuit shown in Figure 3 forms a PWM that is intended to transmit an isolated representation of a voltage differ-

APPLICATIONS INFORMATION

ence, rather like an isolated instrumentation amplifier. The section B comparator is used to generate a 2V reference supply level for the CMOS NOT gate (inverter), which serves as the precision switch element for the charge balancer. The heart of the charge balancer is the section A comparator, which is detecting slight charge or discharge states on the 0.22μF “integration” capacitor as it remains balanced at ≈400mV by feedback through the NOT gate. The input sense voltage, V_{IN} , is converted to an imbalance current that the NOT gate duty cycle is continually correcting for, thus the digital waveform at the section A comparator output is a PWM representation of V_{IN} with respect

to the 2V “full scale.” In this particular circuit, the PWM information drives the LED of an optocoupler, allowing the V_{IN} information to be coupled across a dielectric barrier. As an additional option to the circuit, the feedback loop can be broken and a second optocoupler employed to provide the charge balance management. This configuration allows for clocking the comparator output (externally to this circuit) and providing synchronous feedback such that a simple $\Delta\Sigma$ voltage-to-frequency conversion can be formed if desired. Approximately 11-bit accuracy and noise performance was observed in a one second integration period for duty factors from 1% to 99%.

APPLICATIONS INFORMATION

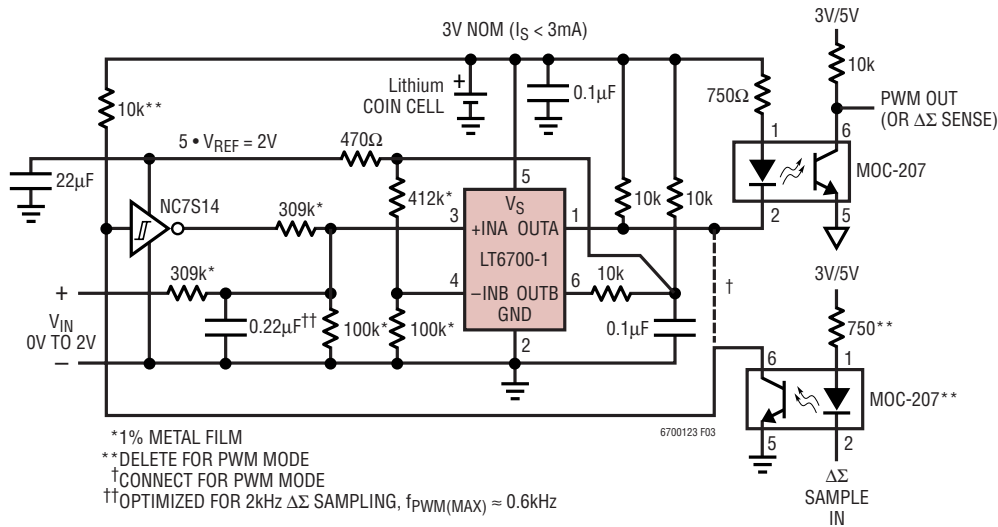
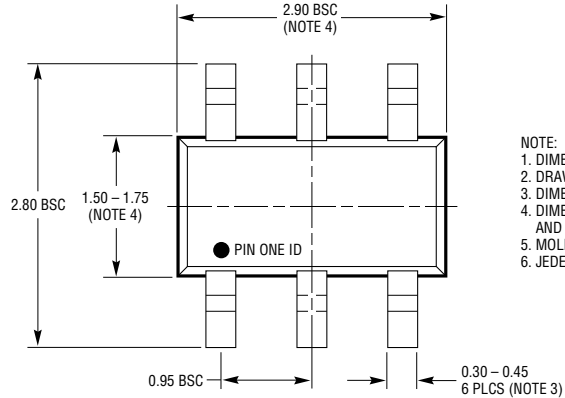
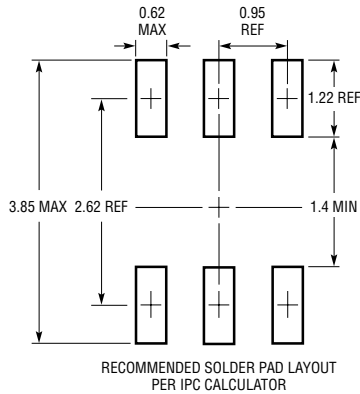

Figure 3. Isolated PWM or $\Delta\Sigma$ Converter

LT6700-1/LT6700-2/LT6700-3

PACKAGE DESCRIPTION

S6 Package
6-Lead Plastic TSOT-23
 (Reference LTC DWG # 05-08-1636)



- NOTE:
 1. DIMENSIONS ARE IN MILLIMETERS
 2. DRAWING NOT TO SCALE
 3. DIMENSIONS ARE INCLUSIVE OF PLATING
 4. DIMENSIONS ARE EXCLUSIVE OF MOLD FLASH AND METAL BURR
 5. MOLD FLASH SHALL NOT EXCEED 0.254mm
 6. JEDEC PACKAGE REFERENCE IS MO-193

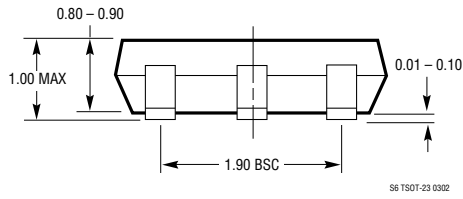
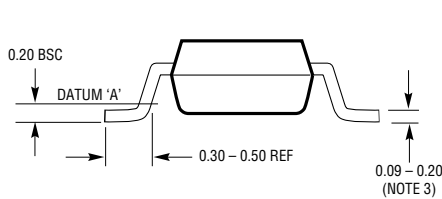

S6 TSOT-23 0302

TYPICAL APPLICATIONS

PowerPath™ Controller

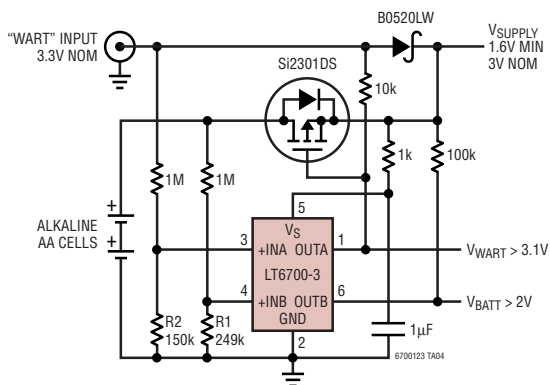

R1 = $400k / (V_{BATT} \text{ AT LOW} - 0.4)$
 R2 = $400k / (V_{BATT} \text{ AT MAX} - 0.4)$
 HYSTERESIS ZONES APPROXIMATELY 2% OF TRIP VOLTAGE
 PowerPath IS A TRADEMARK OF LINEAR TECHNOLOGY CORPORATION

48V Status Monitor

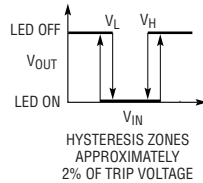
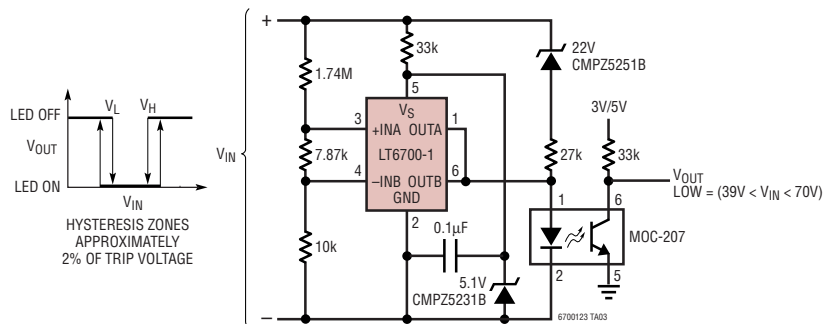

RELATED PARTS

PART NUMBER	DESCRIPTION	COMMENTS
LT1017/LT1018	Micropower Dual Comparator	1.1V (Min) Supply Voltage, $\pm 1.4\text{mV}$ (Max) Input Offset
LTC1441/LTC1442	Micropower Dual Comparator with 1% Reference	$1.182 \pm 1\%$ Reference, $\pm 10\text{mV}$ (Max) Input Offset
LTC1998	Micropower Comparator for Battery Monitoring	$2.5\mu\text{A}$ Typ Supply Current, Adjustable Threshold and Hysteresis

6700123fa