

DESIGN NOTES

New Instrumentation Amplifiers Maximize Output Swing on Low Voltage Supplies – Design Note 323

Glen Brisebois

INTRODUCTION

Instrumentation amplifiers suffer from a chronic output swing problem, even when the input common mode range and output voltage swing specifications are not violated. This is because the first stage of an instrumentation amplifier has internal output voltages that can clip at unspecified levels. The clipping itself is invisible to the user, but it affects the output swing adversely, usually causing a gain reduction and thus an invalid result. The new LTC[®]6800 and LT[®]1789-10 both solve this output swing problem, but in two extremely different ways. The LTC6800 incorporates a flying capacitor differential level shifter followed by a rail-to-rail output autozero amplifier. The LT1789-10 is a more classical three op amp instrumentation amplifier with the twist that it takes gain in the final stage.

A CLEARER PICTURE OF THE PROBLEM

Figure 1 shows the classical three op amp instrumentation amplifier (IA) topology. Assume that the op amps involved can common mode to V_S^- and have rail-to-rail output stages. This would normally mean that the inputs can be anywhere from V_S^- to about a volt from V_S^+ and

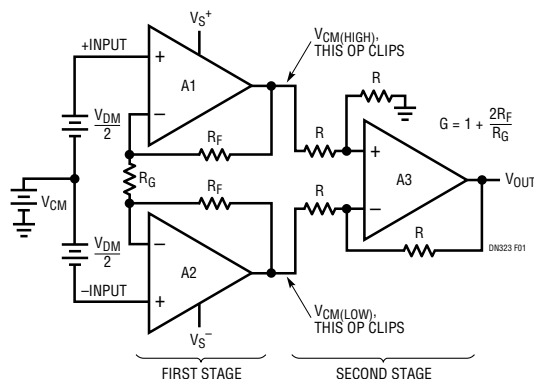

Figure 1. Classical Three Op Amp Instrumentation Amplifier. First Stage can Have Clipping Problems Depending on V_{CM} . This Reduces the Gain and Gives a False Output Reading

that the output can be anywhere within the supply rails. But analysis of the circuit shows that these conditions are not sufficient to ensure a valid output.

For example, assume that the IA is powered on a single 5V supply ($V_S^+ = 5V$, $V_S^- = 0V$), set for a gain of 3 ($R_G = R_F$), and that its inputs are centered at $V_{CM} = 0.5V$. Now, as the differential input voltage is increased around the 0.5V common mode, the output voltages of amplifiers A1 and A2 split apart as well. Note what happens, though, when the differential input voltage (V_{DM}) reaches 1/3V. At that point, the output of A1 goes to 1V and the output of A2 goes to 0V, where it is clipped by the negative supply rail. This happens in spite of the fact that no specified input common mode range or specified output swing has been exceeded.

What can be misleading about this particular error mode is that the gain does not fall to zero, so bench validation tests performed in haste may not catch the problem. The gain is reduced, but there is still a partial signal gain path maintained by A1 and A3 (until A3 clips, of course). Figure 2 shows the entire range of valid output swing vs input common mode for an IA similar to that described above powered on a single 5V supply¹. Note that with the inputs near ground or near 4V, the IA has essentially no valid output swing!

¹LTC and LT are registered trademarks of Linear Technology Corporation.

¹This plot is actually taken from an LT1789-1 and incorporates improvements near ground due to a level shifting input PNP stage.

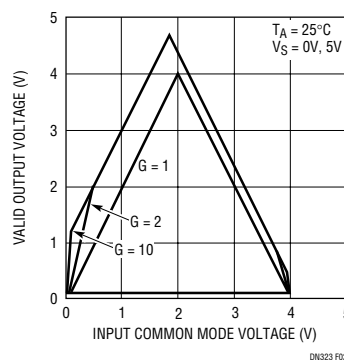

Figure 2. Using Rail-to-Rail Output Op Amps Doesn't Guarantee Output Swing over Input Common Mode

THE SOLUTIONS

Figure 3 shows the same plot, this time for an LT1789-10. Note the drastic improvement. A simplified schematic of the LT1789-10 is shown in Figure 4. The PNP transistors on the inputs serve to level shift the input voltages up by one V_{BE} , thus ensuring valid small-signal input and output ranges (for A1 and A2) near V_S^- . But the real key to the dramatic improvement in output swing is the gain of 10 in the last stage. By taking gain in the last stage, the outputs of the first stage are not required to swing as much for a given overall gain setting and desired output swing.

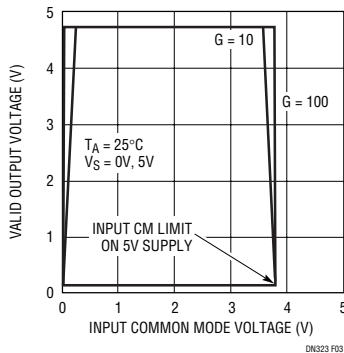

Figure 3. The LT1789-10 Gives Effective Rail-to-Rail Output Validity over Almost the Entire Input Common Mode Range

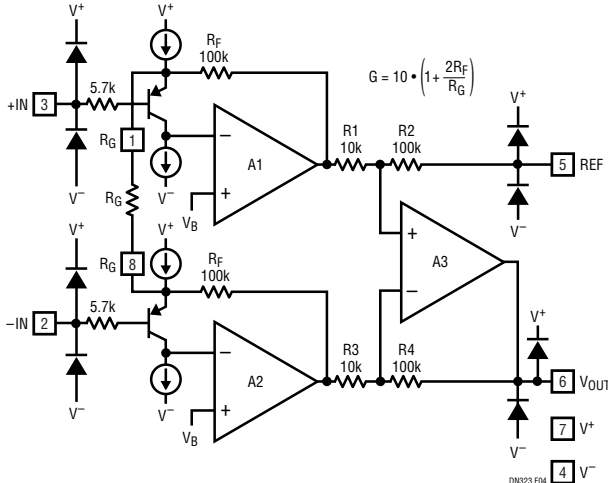

Figure 4. The LT1789-10 Block Diagram. PNP Inputs Level Shift Away from V_S^- . Gain of 10 Around A3 Eases Output Swing Requirements on A1 and A2

The LTC6800 Solution

The LTC6800 achieves similar immunity from the output swing vs input common mode problem, but in a completely different way. The device incorporates a flying capacitor differential level shifter followed by a very precise autozero output op amp as shown in Figure 5. The rail-to-rail output op amp is gain configurable in the conventional 2-resistor way, and follows the usual noninverting gain equation $G = 1 + R_F/R_G$.

Figure 6 shows the valid output swing vs input common mode for the LTC6800. In a gain of 1, the output validity is clipped to about 3.5V by the input common mode range of the op amp A1. Elsewhere in the plot, the ramp-like limitation characteristics are due to the input referred voltages at the rail-to-rail input switches and capacitors clipping at the supply rails. Like the LT1789-10, the LTC6800 performance represents a dramatic improvement over the classical results of Figure 2.

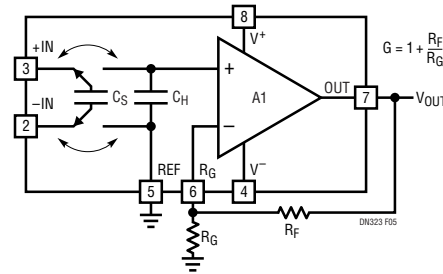

Figure 5. The LTC6800 Block Diagram with External Gain Set Resistors also Shown

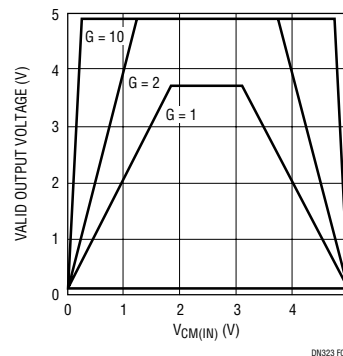

Figure 6. The LTC6800 Output Swing vs Input Common Mode. Drastic Improvement over Classical Architecture

Data Sheet Download

<http://www.linear.com/go/dnLTC6800>
<http://www.linear.com/go/dnLT1789-10>

For applications help,
 call (408) 432-1900, Ext. 2156