

DESIGN NOTES

Monolithic Synchronous Regulator Drives 4A Loads with Few External Components – Design Note 328

Joey M. Esteves

Introduction

The LTC[®]3414 offers a compact and efficient voltage regulator solution for point of load conversion in electronic systems that require low output voltages (down to 0.8V) from a 2.5V to 5V power bus. Internal power MOSFET switches, with only 67m Ω on-resistance, allow the LTC3414 to deliver up to 4A of output current with efficiency as high as 94%. The LTC3414 saves space by operating with switching frequencies as high as 4MHz, enabling the use of tiny inductors and capacitors.

The LTC3414 employs a constant frequency, current-mode architecture and can deliver up to 4A of output current. The switching frequency can be set between 300kHz and 4MHz by an external resistor; alternatively, it can be synchronized to an external clock where each switching cycle begins at the falling edge of the external clock signal. For improved thermal management, the LTC3414 is offered in a 20-lead TSSOP package with an exposed pad to facilitate heat transfer.

The LTC3414 can be configured for either Burst Mode[®] operation, pulse skipping or forced continuous operation. Burst Mode operation maximizes light-load efficiency and extends battery life by reducing gate charge losses at light loads—at no load, the LTC3414 consumes a mere 64 μ A of supply current. Forced continuous operation maintains a constant frequency throughout the entire load range, making it easier to filter the switching noise and reduce RF interference—important for EMI-sensitive applications. Pulse skip mode provides a good compromise between light load efficiency and output voltage ripple.

The LTC3414 provides for external control of the burst clamp current level, in effect allowing the burst frequency to be varied. Lower Burst Mode operating frequencies result in improved light load efficiencies, but there is a trade-off between light load efficiency and output voltage ripple—as the Burst Mode frequency decreases, the output ripple increases slightly. In the LTC3414, the burst clamp is adjusted by varying the DC voltage at the SYNC/MODE pin within a 0V to 1V range. The voltage level at this pin sets

the minimum peak inductor current during each switching cycle in Burst Mode operation. Pulse skip mode is implemented by connecting the SYNC/MODE pin to zero volts. In pulse skip mode, the burst clamp is set to zero current and the minimum peak inductor current is determined by the minimum on-time of the control loop. Pulse skipping minimizes the output voltage ripple by providing the lowest possible inductor current ripple.

High Efficiency 2.5V/4A Step-Down Regulator

Figure 1 shows a 2.5V step-down DC/DC converter that is configured for Burst Mode operation. This circuit provides a regulated 2.5V output at up to 4A from a 2.7V to 4.2V input.

LT, LTC, LT, Burst Mode and OPTI-LOOP are registered trademarks of Linear Technology Corporation.

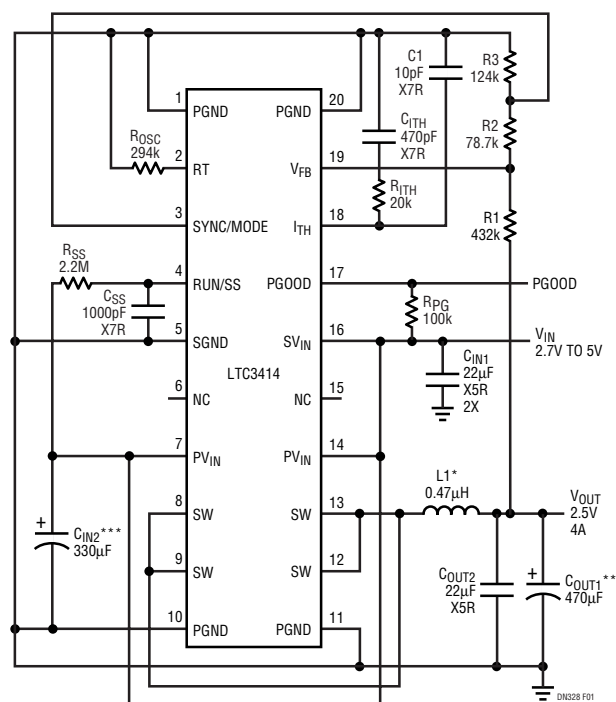

* VISHAY DALE IHL-2525CZ-01
 ** SANYO POSCAP 4TPD470M
 *** SANYO POSCAP 6TPB330M

Figure 1. 2.5V/4A Regulator, Burst Mode Operation

Efficiency for this circuit, shown in Figure 2, is as high as 94% for a 3.3V input voltage. The switching frequency for this circuit is set at 1MHz by a single external resistor, R_{OSC} . Operating at frequencies this high allows the use of a lower valued (and physically smaller) inductor.

In this particular application, Burst Mode operation maintains the high efficiency at light loads. The burst clamp current is set by the R2 and R3 voltage divider, which generates a 0.49V reference at the SYNC/MODE pin. This corresponds to approximately 1.2A minimum peak inductor current, as shown in Figure 2.

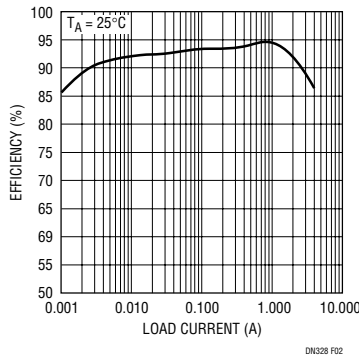

Figure 2. Efficiency vs Load Current 3.3V to 2.5V Burst Mode Operation from Figure 1

High Efficiency 3.3V/4A Step-Down Regulator with All Ceramic Capacitors

Figure 3 shows a 3.3V step-down DC-DC converter using all ceramic capacitors. This circuit provides a regulated 3.3V output at up to 4A from a 5V input voltage. Efficiency for this circuit, shown in Figure 4, is as high as 93%. Ceramic capacitors offer low cost and low ESR, but many switching regulators have difficulty operating with them because the extremely low ESR can lead to loop instability. The phase margin of the control loop can drop to inadequate levels without the aid of the zero that is normally generated from the higher ESR of tantalum capacitors. The LTC3414, however, includes OPTI-LOOP[®] compensation, which allows it to operate properly with ceramic input and output capacitors. The LTC3414 allows loop stability to be achieved over a wide range of loads and output capacitors with proper selection of the compensation components on the I_{TH} pin.

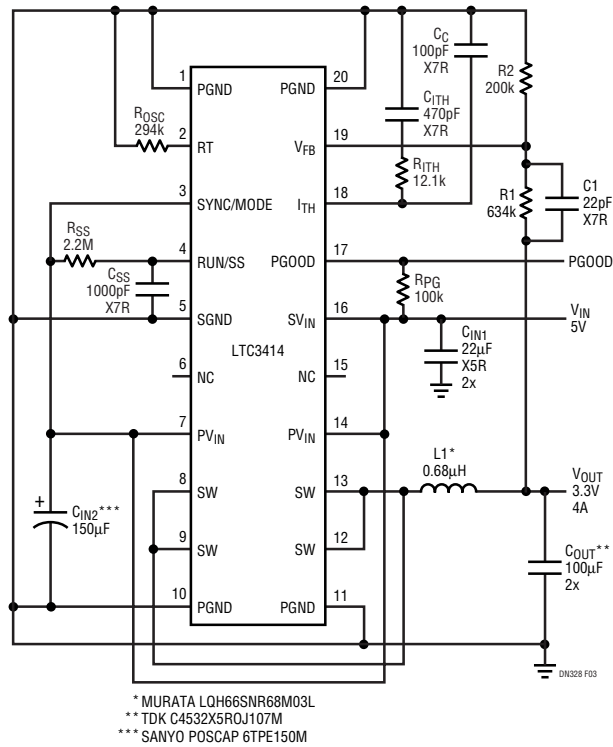

Figure 3. 3.3V/4A Regulator, Forced Continuous Mode

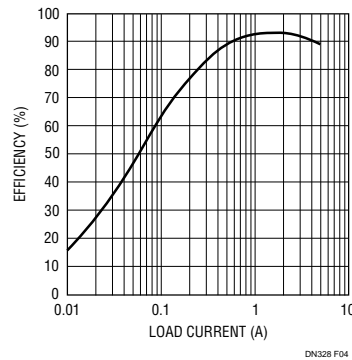

Figure 4. Efficiency vs Load Current, 5V to 3.3V, Forced Continuous

Conclusion

The LTC3414 is a monolithic, synchronous step-down DC/DC converter that is well suited for applications requiring up to 4A of output current. Its high switching frequency and internal low $R_{DS(ON)}$ power switches make the LTC3414 an excellent choice for compact, high efficiency power supplies.

Data Sheet Download

<http://www.linear.com/go/dnLTC3414>

For applications help,
call (408) 432-1900, Ext. 2968