

DESIGN NOTES

60V Step-Down DC/DC Converter Has Only 100 μ A Quiescent Current – Design Note Web 9

Keith Szolusha

Introduction

High voltage bipolar monolithic step-down converters are usually optimized for high efficiency at high output currents. But the consumption of over 1mA quiescent current at zero load can be undesirable in battery-powered applications which operate with long periods of light load current. Although a shutdown function may reduce the quiescent current in order to save battery life, it also drops the output voltage to zero. In systems where a regulated output voltage is always needed for light load applications such as system diagnostics (and ready-to-use load transients), a solution with high efficiency at light load is needed.

The LT[®]1976 is designed to optimize efficiency over all current levels, both high and low, with an extremely wide input voltage range. Micropower bias current and Burst Mode[®] operation enable it to consume a mere 100 μ A at zero load and 12V input. The high efficiency bipolar NPN power switch (0.2 Ω) provides up to 90% efficiency at load current up to 1.25A.

The LT1976 is a 1.5A monolithic buck switching regulator. Its 3.3V to 60V input voltage range makes the LT1976

ideal for 14V and 42V (future) automotive applications which must meet both sub-4V cold crank and high input voltage transients (up to 60V). Additionally, high input voltage and low quiescent current make this an ideal solution for many 48V nonisolated telecom applications, 40V FireWire[®] peripherals and multiple source handheld battery-powered applications with autoplug adaptors. The LT1976 can survive load-dump input transients up to 60V that are common in these systems designed to run at a fixed frequency of 200kHz, the LT1976 can also be synchronized at frequencies up to 700kHz. The shutdown pin provides a 2.4V undervoltage lockout threshold as well as a 1.3V threshold for micropower shutdown (<1 μ A). A single capacitor provides soft-start capability and limits inrush current and output voltage overshoot. A power good flag and power good comparator provides the system with an indication that either the output voltage, the input voltage or some other line is good or bad. The LT1976 is provided in a small 16-pin TSSOP thermally enhanced package to provide optimal thermal performance.

LT, LTC, LT and Burst Mode are registered trademarks of Linear Technology Corporation. FireWire is a registered trademark of Apple Corporation.

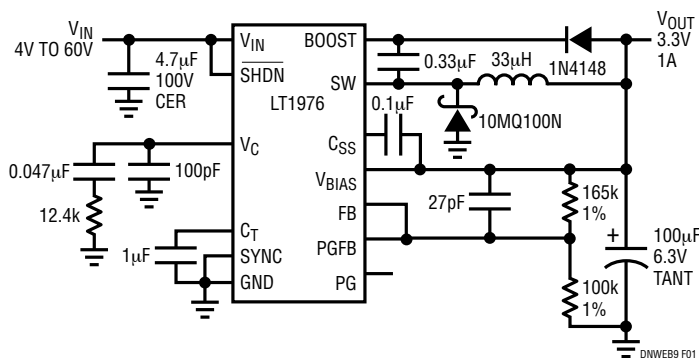

Figure 1. Typical LT1976 Automotive DC/DC Converter Delivers 1A at 3.3V

Burst Mode Operation

A typical automotive step-down application, 14V or 42V (with 60V transients) to 3.3V DC/DC converter (with ability to run at 4V input for cold crank), is shown in Figure 1. Burst Mode operation reduces light load quiescent current by disabling switching for a number of switch cycles and placing the part briefly in micropower shut-down until switching begins again. Bursts of switch pulses are enough to maintain output voltage regulation at light load as shown in Figure 2, the efficiency peaks under normal 'loaded' operation between 100mA and 1A. However, light load efficiency demonstrates how little quiescent current is drawn from the battery during long periods of system inactivity. Figure 3 demonstrates how, over most typical input voltages, zero load quiescent current is below 100 μ A.

Soft-Start

A single capacitor, C_{SS} , shown in Figure 1, is all that is required for soft-start. It is common for switchers without soft-start to operate at peak switch-rated current during start-up. This surge of current can pull down a battery source voltage and cause overshoot in the output voltage. The soft-start capacitor with the LT1976 controls the output voltage ramp-up rate, allowing it to slowly rise upon start-up. This reduces the inrush current surge and limits output voltage overshoot.

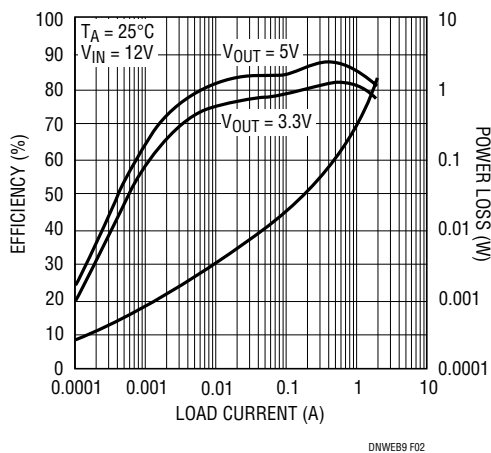

Figure 2. Efficiency vs Load Current for Circuit in Figure 1

Data Sheet Download

<http://www.linear.com>

Power Good

For systems that rely upon having a well-regulated power source or follow a particular power-up sequence, the LT1976 provides a power good flag with timed delay programmed by C_T when the power good feedback pin exceeds 90% of V_{REF} (1.25V). By connecting the power good feedback pin (PGFB) directly to the feedback pin (FB), the power good comparator will return a "good" signal only when the output voltage has reached 90% and the delay time determined by the capacitor on the C_T pin has been exceeded. The power good feedback pin can also be used to monitor the input voltage, an external source or a resistor divider taken from any of these.

LT1976 Features

- Wide Input Voltage Range: 3.3V to 60V
- <100 μ A Quiescent Current at 12V
- 1.5A Peak Switch Current
- Small 16-Pin Thermally Enhanced TSSOP Package
- Constant 200kHz Switching Frequency
- 0.2 Ω Saturating Switch
- Peak Switch Current Maintained over Full Duty Cycle Range
- <1 μ A Shutdown Current
- 1.25V Feedback Reference
- Synchronizable up to 700kHz
- Single Capacitor Programmable Soft-Start
- Power Good Comparator and Flag with Programmable Time Delay

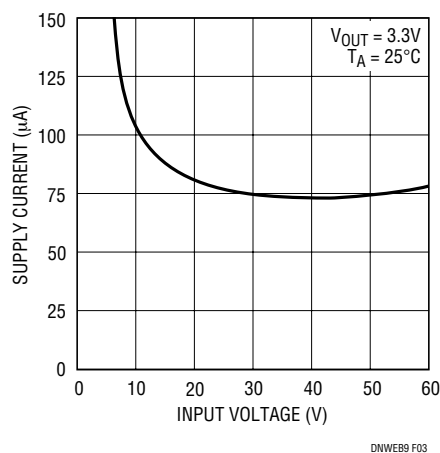

Figure 3. Supply Current vs Input Voltage for the LT1976

For applications help,
call (408) 432-1900, Ext. 2759