

IN THIS ISSUE . . .

COVER ARTICLE

**The LT[®]1160 and LT1162:
Medium Voltage, N-Channel
Bridge Design Made Easy**
..... 1
Jaime Tseng

Editor's Page 2
Richard Markell

LTC in the News 2

DESIGN FEATURES

**The LT1166: Power Output
Stage Automatic Bias
System Control IC** 3
Dale Eagar

**The LT1186: A Simple
Bits-to-Light Converter for
LCD Displays** 6
Anthony Bonte

**Power Factor Correction,
Part Four: The Brains
Behind the Brawn** 10
Dale Eagar

**How Do You Slew 200V/ μ s
with a 250 μ A Op Amp?**
..... 12
George Feliz

DESIGN IDEAS

..... 17-26
(complete list on page 17)

New Device Cameos 27

Design Tools 28

Sales Offices 28

The LT1160 and LT1162: Medium Voltage, N-Channel Bridge Design Made Easy

by Jaime Tseng

Introduction

The new LT1160 is a second-generation, half-bridge, N-Channel power MOSFET driver. The LT1160, which is derived from the LT1158 half-bridge driver, has an increased voltage handling capability and a higher output drive current. The LT1162 is a full-bridge version of the LT1160

Like its predecessor, the LT1160 effectively deals with the many problems and pitfalls encountered in the design of high efficiency motor-control and switching regulator circuits. This article will discuss these problems, along with the solutions the LT1160 offers the bridge designer.

LT1160 Overview

Figure 1 is a block diagram of the LT1160 (the LT1162 has two circuits identical to that in Figure 1). New in the LT1160 are two independent undervoltage-detect circuit blocks that disable the drivers when either the supply voltage or the voltage across the bootstrap capacitor drops below its undervoltage trip point. Two input pins control the switching of both N-channel MOSFETs; both channels are noninverting drivers. The internal logic prevents both outputs from turning "ON" simultaneously under

any input condition. When both inputs are high, both outputs are actively held low.

Bipolar versus CMOS Drivers

Bipolar technology was chosen for operation to 60V (absolute maximum) due to its inherent greater-than-60V junction-breakdown voltage. This is particularly important in an N-channel topside driver, which must operate above the supply rail. In addition, bipolar technology provides consistent drive capability, resulting in transition times that increase moderately with large increases in capacitive load. The LT1160 switches 1,000pF loads in 75ns, but for 10,000pF loads, this only increases to 180ns, making operation to 100kHz possible with the largest MOSFETs. Figures 2a shows a simplified schematic of the LT1160 output stage; Figure 2b shows how it delivers progressively more current as the capacitive load increases. On the other hand, CMOS drivers' switching times tend to be fast at light loads but increase rapidly at higher capacitive loads, as shown in Figures 3a and 3b.

continued on page 14

LT, LTC and LT are registered trademarks of Linear Technology Corporation. Burst Mode, Bits-to-Nits and C-Load are trademarks of Linear Technology Corporation.



On Being Analog in Silicon Valley

by Richard Markell

Working in Silicon Valley is interesting. The hottest technologies blow through, virtually overnight. Sometimes the technologies take off, and sometimes they self-destruct. But we at LTC need to know what's coming so that we can design analog circuitry that allows the fast-paced digital world to talk to our linear world. The micro-processor gurus might dispute it, but the expertise required to optimize the transient response of a DC/DC converter is nontrivial. The IC designer must know a multiplicity of disciplines, from transistor-level integrated circuit simulation to the system-level ESR requirements of capacitors. We at LTC pride ourselves on being the best in the industry at what we do, whether it's building applications circuits for customers, designing IC's or taking an order in customer service. The design of ASICs, multimedia and networks may be hot today, cold tomorrow, but analog will always be with us. We press on, growing at a good clip, supplying the analog core to the world of digital designers. We are always looking for people who are in love with analog circuit design.

Our feature article highlights the LT1160 and LT1162 N-channel MOSFET half- and full-bridge drivers, with increased maximum operating voltage (60V abs. max.) and higher output drive current. Also new to these topologies is undervoltage lock-out, which disables the drivers when either the supply voltage or the voltage across the bootstrap capacitor drops below its trip point. Cross-conduction or "shoot-through" has been completely eliminated. The LT1160 and LT1162 will see use as motor-control circuits, high current, high-efficiency switching regulators and other half- and full-bridge driver circuitry.

Another "control" device is the new LT1186 Bits-to-Light converter for LCD displays. The LT1186 is a companion part to LTC's LT1182/LT1183/LT1184 CCFL/LCD contrast switching regulator family of devices. The LT1186 adds simple digital control for CCFL to a fixed frequency, current mode switching regulator. The device incorporates a micropower 8-bit, 50 μ A full-scale, current output DAC that provides the "bits-to-lamp-current" control. The device communicates in two modes: standard SPI and pulse mode.

The LT1352 is a new micropower operational amplifier that can slew 200V/ μ s and settle to 0.1% in 700ns for a 10V step. The LT1352 is stable with any capacitive load and can drive heavy loads (\leq 40mA) with low distortion. These specifications are achieved without compromising other specifications over the part's \pm 2.5V to \pm 15V supply range. Another Design Feature spotlights the LT1166, a power output stage automatic bias system control IC. The part is designed to optimize amplifier output stage biasing (and quiescent current) and to eliminate the need for temperature tracking, matching transistors or trim pots. The device allows automatic biasing of an amplifier's output stage in the Class AB operational region.

In this issue we present the fourth and concluding part of the "Power Factor Correction" series. Also provided with this issue is an index of circuits presented in the first five years of the *Linear Technology Magazine*.

This issue also has the usual selection of Design Ideas, carefully chosen and tested in our Applications Lab. Here we have circuits ranging from GTL terminators to rail-to-rail filters. **LT**

LTC in the News...

Once again Linear Technology reports another quarter of record sales and profits. Net sales for LTC's first quarter ending October 1, 1995 were a record \$87,005,000, an increase of 50% over net sales of \$58,082,000 for the previous year. The company also reported record net income for the quarter of \$30,520,000 or \$0.39 per share, an increase of 71% over \$17,830,000 or \$0.24 per share reported for the first quarter of the last year.

More good news was reported in *Investor's Business Daily* September 29th issue, which featured a corporate profile under their New America section. Bob Swanson talked about the continuing need for analog circuitry. "We cheer the growth of digital, but when the rubber hits the road, we live in an analog world and we don't see this ever changing."

In *Financial World* October 10, 1995 issue Linear Technology Corporation was included on its list of "America's Best 100 Growth Companies." LTC was ranked #22 out of all the companies considered: #3 for semiconductors and #1 for analog!

In the "What's Hot for Product" category, *Electronic Design* October 13, 1995 issue highlighted the LTC1410 in a feature article titled "12-Bit IC ADCs Relieve Error Budgets." The LTC1410 is the fastest 12-bit Successive Approximation (SAR) based ADC to date. The part uses a novel design technique to achieve excellent power and cost performance. The LTC1410 joins LTC's fast growing line of A to D and D to A products for high performance applications. **LT**

Authors can be contacted
at (408) 432-1900

The LT1166: Power Output Stage Automatic Bias System Control IC

by Dale Eagar

Introduction

Class AB amplifiers are popular because of their “near Class A” performance and their ability to operate on considerably less quiescent power than Class A. Class AB amplifiers are easy to construct, rugged and reliable. However there is an aspect of these amplifiers that can cause perplexity, consternation and finally hair loss—their bias scheme. The problem is that the very parameter that makes Class AB so good, namely low quiescent current, is poorly controlled. The LT1166 offers control over the quiescent current directly, removing the necessity of temperature tracking, matching transistors or trim pots.

Functional Description

The LT1166 (Figure 1) controls the Class AB output stage by incorporating two control loops, the current-control loop and the voltage-control loop. The current-control loop (Figure 2) operates independently of the voltage loop while keeping the

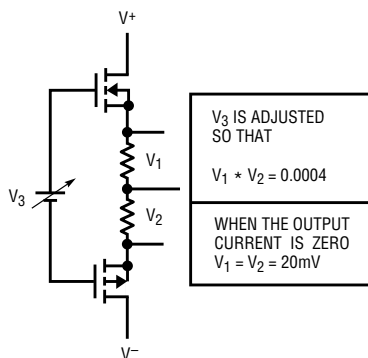

Figure 2. LT1166 Current-control loop

product of V_1 and V_2 constant. The voltage loop (Figure 3) maintains the output voltage at the input voltage level by driving both gates up or down. The two loops, although mutually independent, act in harmony to provide a component insensitive, temperature insensitive, simple Class AB bias network.

Crossover Distortion

Adjusting the bias point of a Class AB amplifier is quite like walking a tight rope. Quiescent current needs to be set precisely; if it is adjusted too low, the amplifier exhibits crossover distortion, whereas if it is adjusted too high, the amplifier becomes a very effective heater. Setting the bias of a Class AB amplifier is often reserved for the “Medicine Man,” an individual with both the smarts to know how to

set bias and the nerves to take the catastrophic results of misalignment. The LT1166 removes all excess crossover distortion caused by improperly set quiescent current, while significantly reducing the distortion caused by the effects of nonlinear transconductance in the output transistors. Figure 4 shows how the magic point for a Class AB amplifier is visualized (keep in mind that the magic point is temperature sensitive in many designs, leading the designer to temperature tracking tricks, which are not needed with the LT1166.)

Makes Random Transistor Pairs into Parallelable Modules

The LT1166, combined with external transistors, implements a unity-gain buffer with an offset voltage of $\pm 50\text{mV}$. This buffer in turn becomes a component that can easily be paralleled to increase the output power (see Figure 5).

Terra Firma!

California, a place where the ground is anything but stable, is now the birthplace of “The Rock,” a virtual ground with an attitude. The Rock (detailed in Figure 6) is a $5\text{V}, \pm 0.4\%$

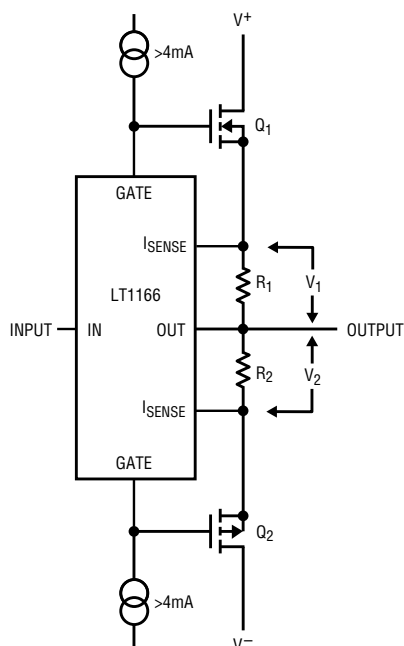

Figure 1. Basic LT1166 circuit configuration

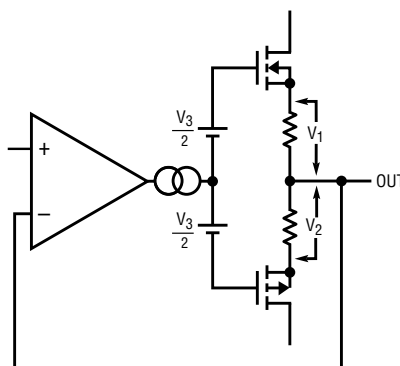

Figure 3. LT1166 Voltage-control loop

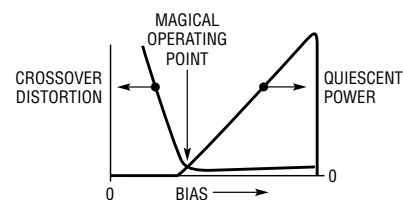

Figure 4. “Magical” operating point of Class AB amplifier

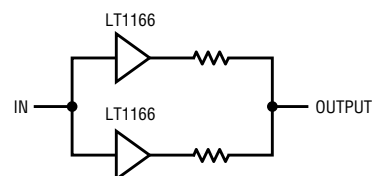

Figure 5. LT1166's can be easily paralleled

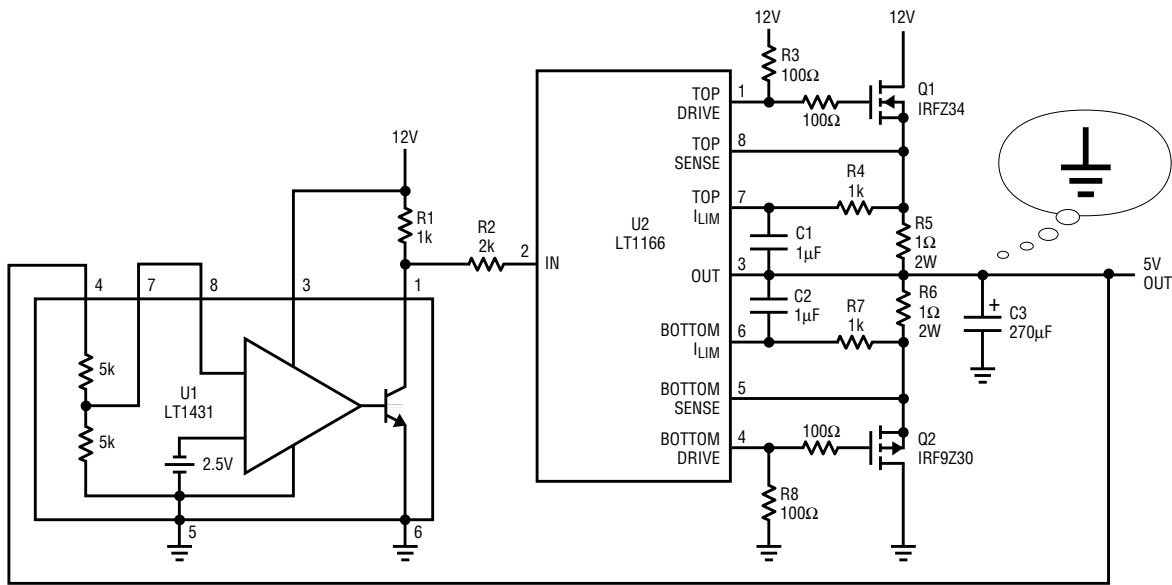

Figure 6. "The Rock," a 5V, ±0.4% tolerance, ±1A low noise voltage source

low noise virtual ground. The Rock will source or sink 1A of current with ease. In this circuit, the current limits are set to 1.5A for both sourcing and sinking currents. Changing the values of R5 and R6 to 0.33Ω increases the output current by a factor of

three. This circuit, properly built, will easily withstand an earthquake of magnitude 8, with unmeasurable output deviation.

Shaker-Table Driver/ Brute Audio Amplifier

In the event that you don't live in California, you might need the circuit shown in Figures 7a-7c, the 1.8kW shaker-table driver/audio amplifier. In Figure 7a, we develop a slice of power by connecting the LT1166 to two power MOSFETs, two current sense resistors and two current

sources. The power slice shown in Figure 7a will deliver 300W of sine wave power into 16Ω when powered from ±100VDC. The MOSFETs and/or the sense resistors can be increased or decreased to get output power in almost any flavor.

Figure 7b details how six power slices can be paralleled to put out a cool, clean 1800W of Richter or 1250W of rock and roll. The LT1360 amplifier operates in the extended supply mode (see "Extending Op Amp Supplies to Get More Output Voltage," *Linear Technology*, IV:2, pp. 20-22).

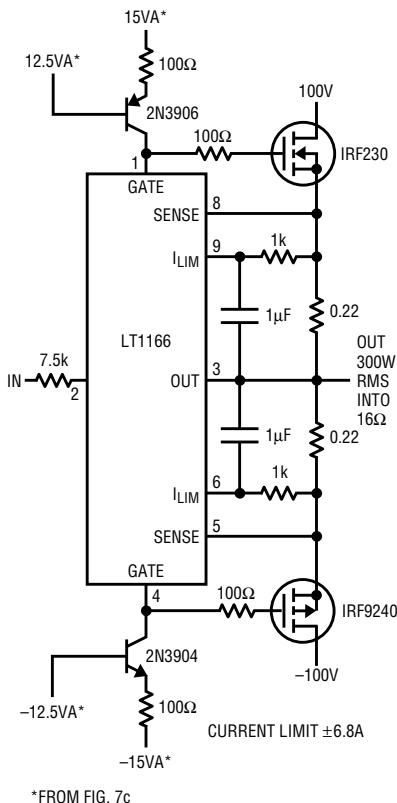

*FROM FIG. 7c

Figure 7a. ±100V, 6A "power slice"

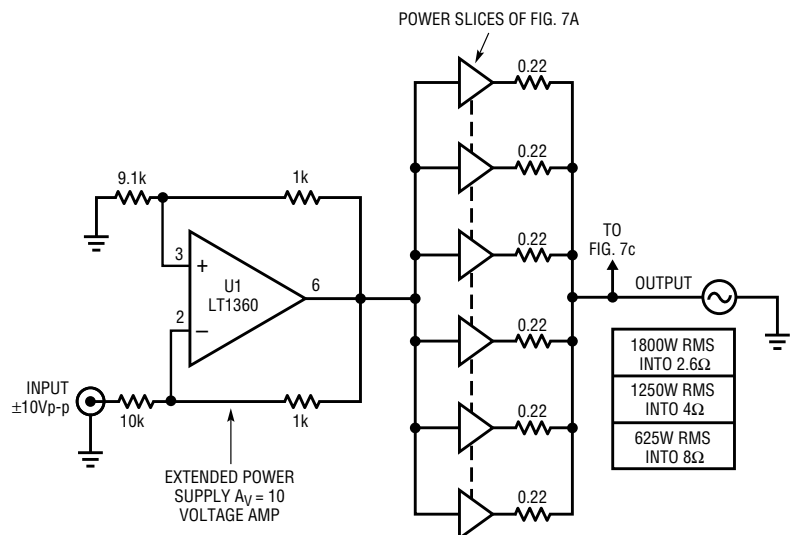

Figure 7b. Paralleling power slices to increase output drive

Finally, Figure 7c shows how to connect the $\pm 15V$ floating supply and also details the PSRR snubber for the LT1360 (R1, R2, R3 and C2).

Ring-Tone Generation

Building upon an earlier *Linear Technology Magazine* article (see above) we show a power ring-tone generator. This generator is detailed

in Figures 7a, 8a and 8b. This circuit starts at 300W (or less if you use smaller FETs and bigger resistors in Figure 7a) and can be stacked up to any desired power level. With this circuit, you could easily build a ringer capable of ringing the phones of every U.S. politician simultaneously (not that this would do any good).

Conclusion

With the advent of the LT1166, biasing Class AB amplifiers becomes trivial. Dependencies on temperature tracking, component matching and alignment pots have succumbed to cool, clean, closed-loop control of operating points. Suddenly, MOSFETs look a lot friendlier to the power amplifier designer. Suddenly, pots have bitten the dust. 

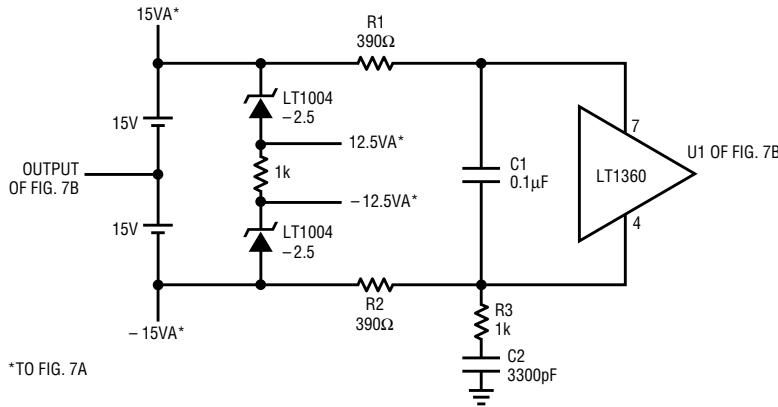

*TO FIG. 7A

Figure 7c. Connection diagram for the $\pm 15V$ floating supply

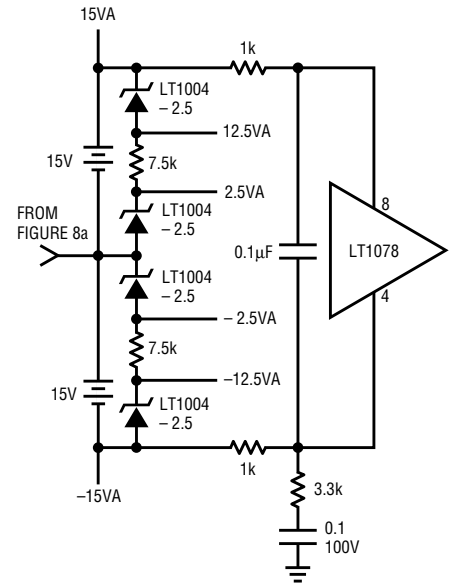
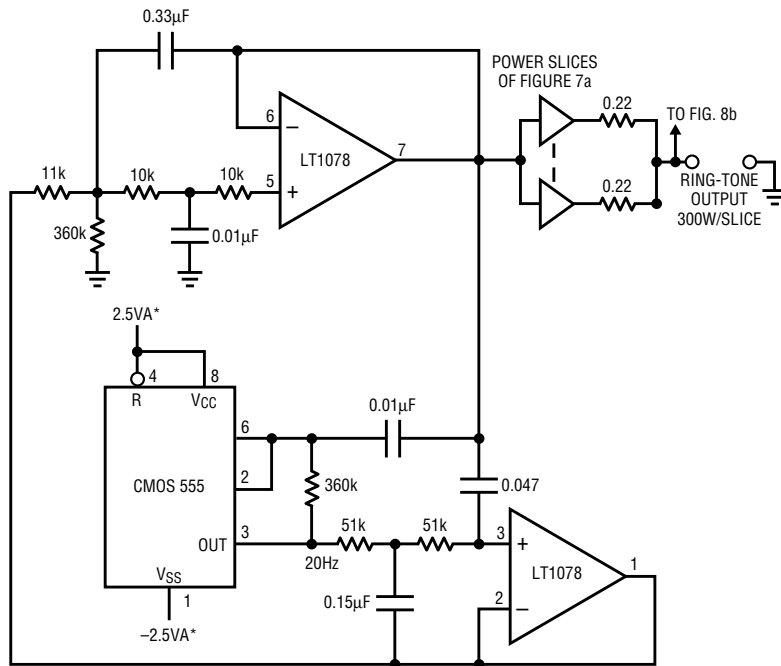

Figure 8b. Power supply circuitry for Figure 8a



*TO FIG. 7c

Figure 8a. Ring-tone generator schematic diagram

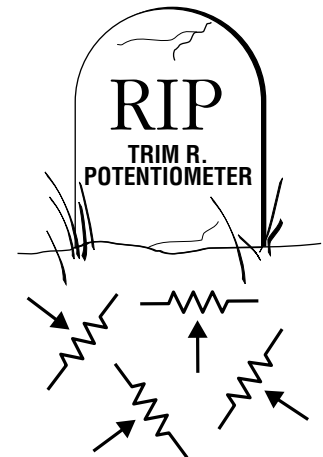

Figure 9. Trim pots are no longer required

The LT1186: A Simple Bits-to-Light Converter for LCD Displays

by Anthony Bonte

Introduction

Many current-generation portable and handheld instruments use backlit liquid crystal displays (LCDs). Cold-cathode fluorescent lamps (CCFLs) provide the highest available efficiency for backlighting the display. These lamps require high voltage AC to operate, mandating an efficient high voltage DC/AC converter. In addition to good efficiency, the converter should deliver the lamp drive in the form of a sine wave. The sine wave excitation helps to minimize RF emissions and also provides optimal current-to-light conversion in the lamp. The circuit should also permit lamp intensity control from zero to full brightness with no hysteresis or "pop-on."

Manufacturers offer an array of monochrome and color displays. These displays vary in size, operating lamp current, lamp-voltage range and power consumption. The small size and battery-powered operation associated with LCD-equipped apparatus

dictate low component count and high efficiency. Size constraints place limitations on circuit architecture, and long battery life is a priority. All components, including pc board and hardware, usually must fit within the LCD enclosure, with a height restriction of 5mm-10mm.

Handheld instruments are generally characterized by dedicated functionality and reduced processing power in comparison with notebook or laptop computers. These portable systems often use general-purpose, low cost microcontrollers such as the Intel 80C51 or Motorola 68HC11. These microcontrollers are popular because of their versatile I/O capability. A simple interface that allows the microcontroller to easily control the operating lamp current and display brightness is required. To address the requirements of these portable instruments, Linear Technology introduces the LT1186 DAC programmable CCFL switching regulator.

New LTC CCFL Part

The LT1186 is a fixed frequency, current mode switching regulator that provides a simple digital control function for cold-cathode fluorescent lighting. The regulator is a companion part to Linear Technology's LT1182/LT1183/LT1184 CCFL/LCD contrast switching regulator family. The LT1186 supports grounded-lamp and floating-lamp configurations. The IC includes an efficient high current switch, an oscillator, output-drive logic, control circuitry and a micropower 8-bit 50µA full-scale current output DAC.

The DAC provides simple "bits-to-lamp-current control" and communicates in two interface modes: standard SPI mode and pulse mode. On power-up, the DAC counter resets to half-scale and the DAC configures itself to SPI or pulse mode, depending on the \overline{CS} (chip select) signal level. In SPI mode, the system microprocessor serially transfers the present 8-bit data and reads back the previous

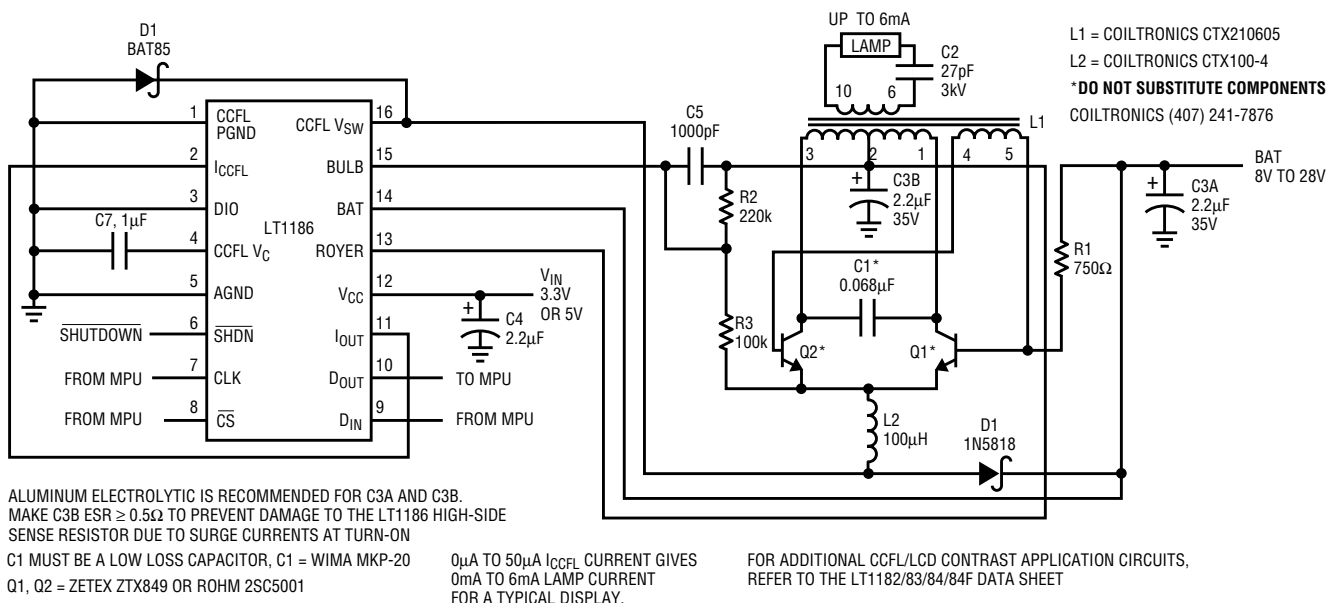

Figure 1. Up to 90% efficient floating CCFL with SPI control of lamp current

8-bit data from the DAC. In pulse mode, the upper six bits of the DAC are configured for increment-only (1-wire interface) or increment/decrement (2-wire interface) operation, depending on the D_{IN} signal level.

The LT1186 control circuitry operates from a logic supply voltage of 3.3V or 5V. The IC also has a battery supply voltage pin that operates from 4.5V to 30V. The LT1186 draws 6mA typical quiescent current. An active low shutdown pin reduces total supply current to 35 μ A for standby operation and the DAC retains its last setting. A 200kHz switching frequency minimizes magnetic component size, and the use of current mode switching techniques gives high reliability and simple loop frequency compensation. The LT1186 is available in a 16-pin, narrow-body SO.

Typical Application

Figure 1 is a complete floating CCFL circuit using the LT1186 in standard SPI mode to control operating lamp current from a microprocessor. A floating-lamp circuit allows the transformer to provide symmetric, differential drive to the lamp. Balanced drive eliminates the field imbalance associated with parasitic lamp-to-frame capacitance and reduces "thermometering" (uneven lamp intensity along the lamp length) at low lamp currents.

Q1, Q2, L1 and C1 form the core of a current-fed, Royer-class converter. The LT1186 power switch and L2 create a switch-mode current source to drive the Royer. The 200kHz switching frequency allows the use of only 100 μ H for L2. Base drive for Q1 and Q2 is provided by L1's tickler winding and R1. R1 is selected to guarantee sufficient base drive with minimum betas for Q1 and Q2. R2, R3 and C5 comprise an external divider network for the open-lamp protection circuit. The divider monitors the voltage across the Royer converter and compares it with an internal 7V clamp voltage between the BAT and BULB pins. Monitoring the primary-side converter current through a high-side sense resistor and amplifier,

connected between the BAT and Royer pins, provides feedback, and a single capacitor (C7) on the V_C pin provides stable loop compensation.

Lamp current is programmed by driving the I_{CCFL} pin from the I_{OUT} pin. The transfer function between lamp current and input programming current must be empirically determined and is dependent on a myriad of factors, including lamp characteristics, display construction, transformer turns ratio and the tuning of the Royer oscillator. The LT1186 control circuitry is powered by either a 3.3V or 5V logic supply, and the input battery voltage range for this example is 8V to 28V. Lower input battery voltage operation is accomplished by increasing the turns ratio of transformer L1 and retuning the Royer by tweaking the values of C1 and C2. Electrical efficiency with typical CCFL lamps ranges between 80%–90% at full load with lamp current being variable from 200 μ A to 6mA for a typical display. The component values chosen are an interactive compromise in maximizing photometric output versus input power.

Figure 2 is a block diagram for an Intel 80C31 microcontroller-based evaluation setup for the LT1186. The lamp current is controlled by a general PC keyboard interface. The user inputs a number between 0 and 255 to set a new input programming current, and therefore, a new lamp current level. The previous code is

returned to the user to verify the last programmed current level. An input of one corresponds to 1 LSB of DAC output current (195.3nA) and an input of 255 corresponds to the full-scale DAC output current of 50 μ A.

Listings 1 and 2 on pages 8–9 are the complete C and assembly language code that controls the evaluation setup of Figure 2. My thanks and appreciation go to Tommy Wu at Linear Technology for developing this software. Any questions or comments regarding the software should be addressed to Tommy, in care of this publication. The software is fairly generic and is easily adaptable to other microcontrollers or microprocessors.

Conclusion

The LT1186 is a novel Bits-to-Nits™* converter for driving cold-cathode fluorescent lamps in handheld or portable instruments with LCD displays. Lamp current is digitally programmed in either of two interface modes: standard SPI mode and pulse mode, which provides simple push-button up/down control. The LT1186 represents another step in Linear Technology's commitment to providing efficient, compact and economical backlight solutions.



Note:

* Bits-to-Nits is a trademark of Linear Technology Corporation. 1 Nit = 1 Candela/meter². Nit is derived from the Latin word *nitere* meaning "to shine."

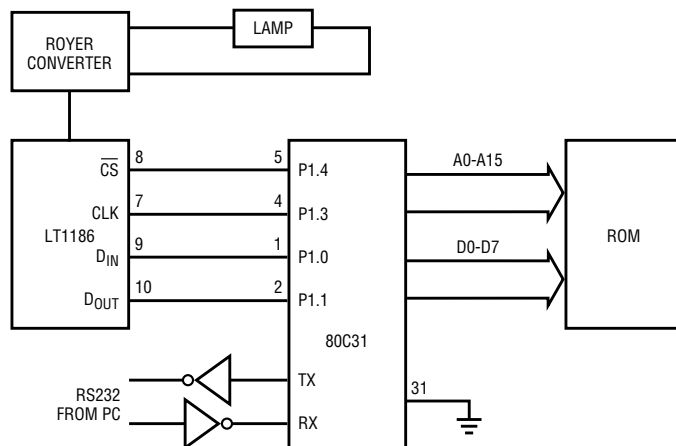

Figure 2. LT1186 Floating CCFL system using an Intel 80C31 microcontroller

C and Assembly Language Program Code for LT1186 Evaluation

The LT1186.C program demonstrates the use of the LT1186 DAC programmable CCFL switching regulator.

The example circuit uses the popular 80C51 family of microcontrollers to interface between the user and the LT1186.

The LT1186 DAC algorithm is written in assembly language, and is contained in a file named LT1186A.ASM; it is called as a function from the MAIN function of LT1186.C. The user inputs an integer from 0 to 255 on a keyboard and the LT1186 adjusts the I_{OUT} programming current to control the operating lamp

current and the brightness of the LCD display. The assembly language program, LT1186A.ASM, receives the D_{IN} word from the main C program function, lt1186(). Assembly to C interface headers, declarations and memory allocations are listed before the actual assembly code.

Listing 1. LT1186.C

```
#include <stdio.h>
#include <reg51.h>
#include <absacc.h>

extern char lt1186(char); /* external assembly function in lt1186a.asm */
sbit Clock = 0x93;

main()
{
    int number=0;
    int LstCode;

    Clock = 0;

    TMOD = 0x20;    /* Establish serial communication 1200 baud */
    TH1 = 0xE8;
    SCON = 0x52;
    TCON = 0x69;

    while(1) /* Endless loop */
    {
        printf("\nEnter any code from 0 - 255: ");
        scanf("%d",&number);
        if((0>number) | (number>255))
        {
            number = 0;
            printf("The number exceeds its range. Try again!");
        }
        else
        {
            LstCode = lt1186(number);
            printf("Previous # %u", (LstCode&0xFF)); /* AND the previous
                number with 0xFF to turn off sign extension */
        }
        number = 0; /* Reinitialize number */
    }
}
```

Listing 2. LT1186A.ASM

```

; Port p1.4 = CS
; Port p1.3 = CLK
; Port p1.1 = Dout
; Port p1.0 = Din
;
NAME LT1186_CCFL
PUBLIC lt1186, ?lt1186?BYTE

?PR?ADC_INTERFACE?LT1186_CCFLSEGMENT CODE
?DT?ADC_INTERFACE?LT1186_CCFLSEGMENT DATA

        RSEG ?DT?ADC_INTERFACE?LT1186_CCFL
?lt1186?BYTE: DS 2

        RSEG ?PR?ADC_INTERFACE?LT1186_CCFL

CS      EQU    p1.4
CLK     EQU    p1.3
DOUT    EQU    p1.1
DIN     EQU    P1.0

lt1186: setb CS                ;set CS high to initialize the LT1186
        mov  r7, ?lt1186?BYTE ;move input number(Din) from keyboard to R7
        mov  p1, #01h         ;setup port p1.0 becomes input
        clr  CS                ;CS goes low, enable the DAC
        mov  a, r7             ;move the Din to accumulator
        mov  r4, #08h         ;load counter 8 counts
        clr  c                 ;clear carry before rotating
        rlc  a                 ;rotate left Din bit(MSB) into carry
loop:   mov  DIN, c            ;move carry bit to Din port
        setb CLK               ;Clk goes high for LT1186 to latch Din bit
        mov  c, DOUT           ;read Dout bit into carry
        rlc  a                 ;rotate left Dout bit into accumulator
        clr  CLK               ;clear Clk to shift the next Dout bit
        djnz r4, loop          ;next data bit loop
        mov  r7, a             ;move previous code to R7 as character return
        setb CS                ;bring CS high to disable DAC
        ret
        END

```

;NOTE: When CS goes low, the MSB of the previous code appears at Dout

Power Factor Correction, Part Four: The Brains Behind the Brawn

by Dale Eagar

The Control Room

In the three previously published parts of our series on power factor correction, we investigated the workings of the “power transfer mechanism” as used in the ever so popular “boost-mode power factor correction conditioner.” This power transfer mechanism is shown in Figure 1 as the “engine room.” Also shown is the “control room,” where the decisions are made and actions taken to make the PFC power conditioner behave like a resistor (the ultimate disguise for a switching power supply). Having had a brief tour of the engine room in an earlier article, we can summarize its workings in a few rules:

1. The amount of power intercepted from the input line is related to the duty factor of the boost engine.
2. When the duty factor is at 0%, no power is intercepted from the input line.
3. Under all conditions, increasing the duty factor will increase the amount of power intercepted from the input line.
4. The boost engine is essentially lossless, so all power intercepted from the input line ends up in the load.
5. The load voltage is to be held constant.
6. The load voltage shall be set above the peak input voltage, where the peak input voltage is 1.414 times the maximum RMS input power-line voltage; this is where the power factor is to be corrected.

If the peak input voltage exceeds the output voltage at any time, the output diode (internal to the boost engine) takes it upon itself to forward conduct, transferring power from the input to the output without any

authorization from the control room. Pure Insubordination! The only way to prevent this disgraceful act by the output diode is to keep the output voltage out of reach of the peak input voltage.

At the Console

In the control room is a control console, a panel with meters and a duty factor control. Sitting in the control seat is the controller, an intelligent entity. The controller is given the task of watching the three meters (Figure 1) and controlling the duty factor to keep things in check.

The controller is given two tasks to perform, namely:

1. Make the input look resistive.
2. Keep the output voltage constant at 386V, regardless of the load current or input line voltage.

Careful inspection of the above two tasks may surprise you. Let’s look at each task separately.

Task One: Making the Input Look Resistive

It would not be too difficult to teach the controller to make the input look resistive. One would need to teach the

controller to watch the input volts and amps while adjusting the duty factor. The duty factor is constantly adjusted to make the input amps equal to some constant (K) times the input volts. Presto resistor! Looking into the input terminals, one would see a pure resistor. The input would look resistive at a value of $Z_{IN} = 1/K$. This impedance would be fairly constant for frequencies from DC to the fastest frequency at which the controller could accurately keep up with things. In the real world there is this guy named Nyquist who says, among other things, that the controller would make serious blunders if he were to try to control the duty factor faster than 1/2 of the switching frequency. With the switching frequency set to somewhere around 100kHz, the input looks resistive from DC to many kiloHertz, which is good enough for the 60Hz line and many of its nasty harmonics.

Careful inspection of the output would reveal an output impedance of V_{OUT}^2/K , a big number. The whole system would look like a constant power source, with the power level set to K times V_{IN}^2 . These observations are entered in the first row of Table 1.

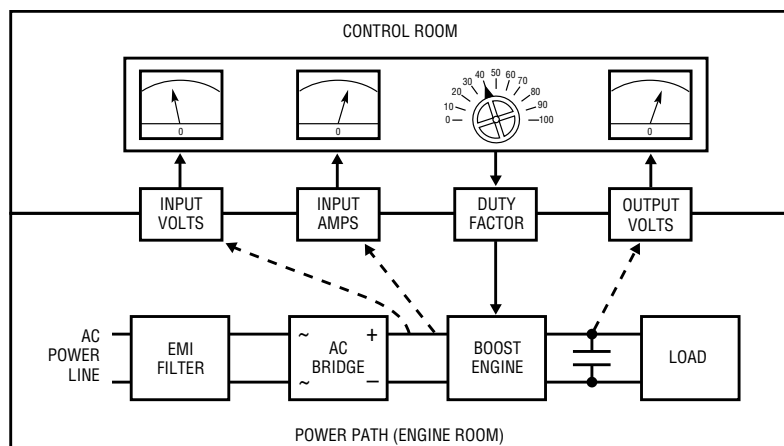

Figure 1. Boost PFC block diagram

Task-2: Keeping the Output Voltage Constant at 386V

Looking at task-2 in the absence of any task-1 constraints, we teach our controller to adjust the duty factor to keep the output voltage constant, regardless of the load current or input line voltage. Having visualized such a system, we can look at its characteristics. Looking into the input port at any constant load current, we see a negative input impedance. (As the input line voltage goes up, the input current goes down.) Looking into the output port we see an impedance of zero. (Any finite increase in output current causes no change in output voltage.) Finally, looking at the power intercepted from the input line we have a constant at $V_{OUT} \times I_{OUT}$ regardless of input voltage. These observations occupy row two of Table 1.

Putting Them Together

It should be apparent that no device can exhibit positive impedance and negative impedance at the same time. However, we know how to cheat—we take the reciprocal of time to get frequency.

This trick doesn't need smoke and mirrors, unless, of course, you hook it up wrong, in which case you get seven years of bad luck. This is a trick in the frequency domain.

The first step is to loosen up the output specification a little. We can see that the power delivered from a sine wave into a resistive load is anything but constant (see Figure 2). We

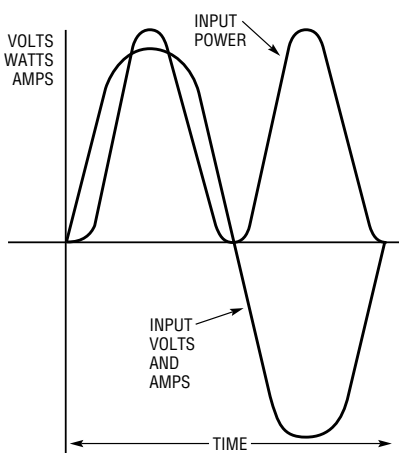

Figure 2. Input power waveform

Task	Input impedance	Output impedance	Power transferred
Make Input Resistive	1/K	V_{OUT}^2/K	$K V_{IN}$
Constant V_{OUT}	Negative	Zero	$V_{OUT} \times I_{OUT}$

would have to have an infinitely large output capacitor to realize zero output ripple when there is input ripple current. Infinite capacitors went out of vogue back in the Cretaceous era. First we loosen up the output voltage specification to allow a few volts of ripple, bringing the output capacitor down to a realistic size. Second, we further loosen the output specification to allow the output voltage to swing tens of volts during heavy load steps.

We do this by teaching the controller to keep the output voltage at 386V when averaged over any 3-second interval. This is in effect telling the controller to make the input impedance negative for frequencies from DC up to several Hertz. We are instructing the controller to adjust the K value in the task-1 operation slowly to keep the output voltage at an average of 386V. See Figure 3 for the input impedance versus frequency characteristics.

Summary/Hindsight

Power factor correction is incorporated into a product design for one of several reasons:

- Government standards, such as IEC555, compliance with which is required to sell product in several worldwide markets.
- The marketing boys upstairs feel that they can sell it as a feature.
- Management needs to keep the power supply design group out of trouble until the next major design.

The boost converter is the best way to perform PFC at any power greater than 50W. The crowning advantage of the boost topology is its continuous input current when running in the continuous mode. The loss of continuity of input current in the discontinuous mode is unimportant, as discontinuous mode only happens

at low input currents where input ripple is less critical.

The boost converter PFC provides no isolation from the line, has high inrush current, has a very high output voltage, has 120Hz ripple on the output and exhibits slow load-step response. All of these difficulties of the boost converter are small compared to the problems in the design of an input EMI filter if other technologies were used.

Isolation, hold-up time and regulation are performed by the switching power supply that follows the PFC conditioner. Inrush protection is provided by a negative tempco thermistor or other external circuitry.

It is advantageous to synchronize the PFC conditioner and the following switching power supply 180 degrees out of phase to reduce the ripple current on the output capacitor and reduce overall system noise. The Linear Technology PFC family of parts all have synchronizing ability, and the LT1508 and LT1509 controllers have both a PFC conditioner and a switching power converter on one chip, fully synchronized at 180 degrees.

The input impedance of a functioning PFC will be negative from DC to about 10Hz; from there the impedance goes reactive, then to positive resistance at frequencies above 10Hz. The output impedance of the PFC conditioner is near zero ohms from DC to about 10Hz; above 10Hz the output impedance looks like a variable resistor in parallel with the output capacitor's reactance.

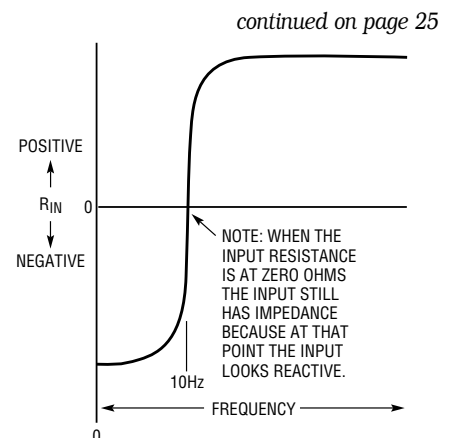

Figure 3. Input impedance (resistive component) versus frequency

continued on page 25

How Do You Slew 200V/ μ s with a 250 μ A Op Amp?

by George Feliz

Introduction

The LT1354/LT1365 family of low power, high-slew-rate op amps changed the relationship between slew rate and supply current found in traditional voltage-feedback operational amplifiers. These parts slew from 400V/ μ s with 1mA supply current up to 1,000V/ μ s with 6mA supply current. The LT1352 dual op amp is a precocious new sibling that extracts 200V/ μ s from a mere 250 μ A of supply current (see Figure 1).

The new design shares the family circuit topology, but adds a frugal output stage that enthusiastically drives heavy loads with up to 40mA of current. A primary benefit, unheard of with other low power op amps, is the ability to drive large signals into heavy loads with low distortion. A plot of distortion for 20V peak-to-peak signals with a 1k Ω load is shown in Figure 2. Table 1 shows that this remarkable output performance is achieved without compromising other specifications over its 2.5V to 15V supply voltage range. The settling time for a 10V step is only 700ns for 0.1% and 1250ns for 0.01%. In addition to performance, the LT1352 is a user-friendly C-Load op amp, which is stable with any capacitive load.

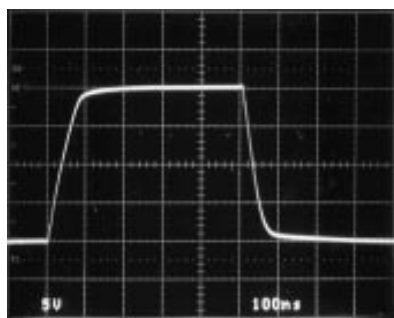

Figure 1. Large-signal response, $A_v = -1$

How We Did It

A simplified schematic of the circuit is shown in Figure 3. The circuit looks similar to a current-feedback amplifier, but both inputs are high impedance, as in a traditional voltage-feedback amplifier. A complementary cascade of emitter followers (Q1-Q4) buffers the noninverting input and drives one side of resistor R1. The other side of the resistor is driven by Q5-Q8, which form a buffer for the inverting input. The input voltage appears across the resistor, generating currents in Q3 and Q4, which are mirrored by Q9-Q11 and Q13-Q15 into the high impedance node. Transistors Q17-Q24 form the output stage. Bandwidth is set by R1, the g_m 's of Q3, Q4, Q7 and Q8, and the compensation capacitor C_T .

The current available to slew C_T is proportional to the voltage that appears across R1. This method of "slew boost" achieves low distortion due to its inherent linearity with input step size. Since large slew currents can be generated without increasing quiescent current, C_T can be increased and R1 can be decreased. Lowering R1 reduces the input noise voltage to 14nV/ $\sqrt{\text{Hz}}$ and helps reduce input offset voltage and drift.

The output stage buffers the high impedance node from the load by providing current gain. The LT1352 and its relatives are single-gain-stage amplifiers in order to remain stable with capacitive loading and to achieve their high slew rate with low quiescent supply current. The simplest output stage would be two pairs of complementary emitter-followers, which would provide a current gain of $\text{Beta}_{\text{NPN}} \times \text{Beta}_{\text{PNP}}$. Unfortunately, this gain is insufficient for driving even a 2k Ω load when running at the low current levels of the LT1352. Adding another emitter-follower can reduce

output swing and/or create instability with a capacitive load.

The solution used on the LT1352 was to create a pair of composite transistors formed by transistors Q19-Q21 and Q22-Q24. The current mirrors attached to the collectors of emitter followers Q19 and Q22 provide additional current gain. The ratio of transistor geometries Q20 to Q21 and Q23 to Q24, and resistor ratios R2 to R3 and R4 to R5 set the gain to five at low currents and to a maximum of 23 at high currents. The variation in gain is required in order to have low quiescent current yet be able to provide output drive on demand. There is no output-swing loss with this output stage, as the swing is limited at the high impedance node. The dynamics of a composite are not as benign as an emitter follower, so compensation is required and is provided by R6, C1 and R7, C2.

The C-Load stability is provided by the R_C , C_C network between the output stage and the high impedance node. When the amplifier is driving a light or moderate load the output can follow the high impedance node and the network is bootstrapped and has no effect. When driving a heavy load such as a big capacitor or small-value

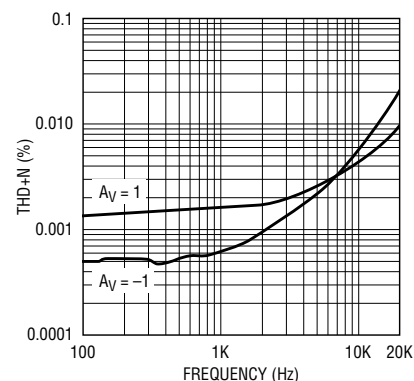

Figure 2. THD + noise, 20V_{P-P}, $R_L = 1\text{k}\Omega$

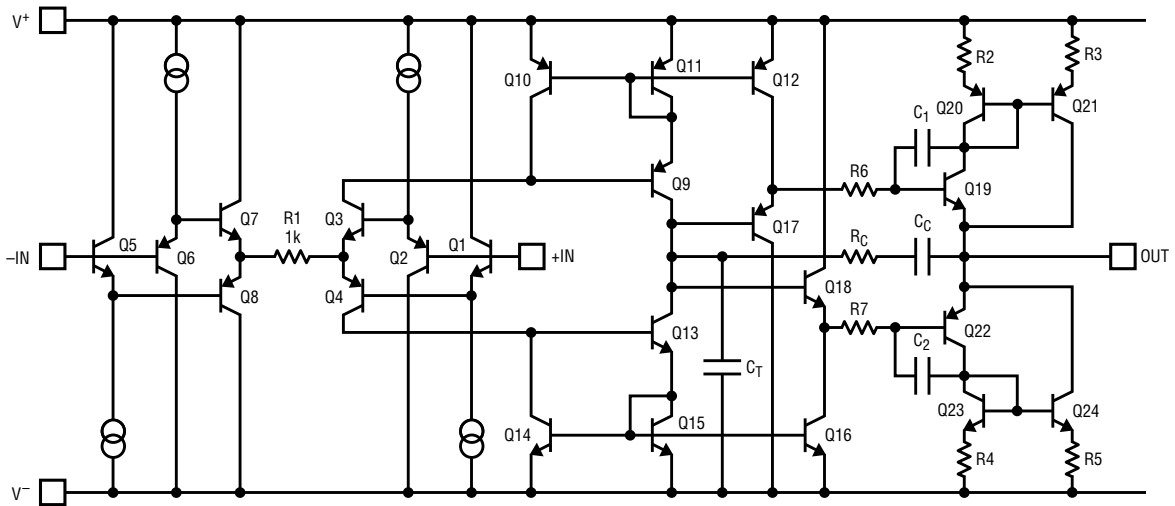

Figure 3. LT1352 simplified schematic

Conclusion

The LT1352 is a dual op amp with an unmatched combination of low supply current, large-signal performance, stability and DC precision. If a figure of merit equal to the slew rate divided by supply current is calculated, the LT1352 stands alone among voltage-feedback op amps with 800V/μs-mA.

resistor, the network is incompletely bootstrapped and adds to the compensation at the high impedance node. The added capacitance provided by C_C slows down the amplifier and the zero created by R_C adds phase margin, ensuring stability. The small-signal

response with a 500pF load is shown in Figure 4 and the large-signal response with 10,000pF is shown in Figure 5. Note that the slew rate in Figure 5 is limited to 4V/μs by the short-circuit current limit of 40mA.

Table 1. Important specifications for the LT1352 at 25°C

Parameter	Conditions	Minimum	Typical	Maximum	Units
V_{OS}	$V_S = 5V, \pm 15V$	300	600		μV
	$V_S = \pm 2.5V$	400	800		μV
I_B	$V_S = \pm 2.5V$ to $\pm 15V$	20	50		nA
I_{OS}	$V_S = \pm 2.5V$ to $\pm 15V$	5	15		nA
A_{VOL}	$V_S = \pm 15V, 1k\Omega$	20	60		V/mV
	$V_S = \pm 5V, 1k\Omega$	20	60		V/mV
	$V_S = \pm 2.5V, 5k\Omega$	20	60		V/mV
GBW	$V_S = \pm 15V$	2.2	3		MHz
	$V_S = \pm 5V$	2.0	2.7		MHz
	$V_S = \pm 2.5V$		2.5		MHz
SR	$V_S = \pm 15V$	125	200		V/μs
	$V_S = \pm 5V$	40	50		V/μs
t_{SETTLE}	10V step, 0.1%		700		ns
	10V step, 0.01%		1250		ns
CMRR	$V_S = \pm 15V$	80	97		dB
	$V_S = \pm 5V$	78	84		dB
	$V_S = \pm 2.5V$	68	75		dB
PSRR	$V_S = \pm 2.5V$ to $\pm 15V$	90	106		dB
Noise voltage	$V_S = \pm 2.5V$ to $\pm 15V, 10kHz$		14		nV/\sqrt{Hz}
Noise current	$V_S = \pm 2.5V$ to $\pm 15V, 10kHz$		0.5		pA/\sqrt{Hz}
Output Swing	$V_S = \pm 15V, 1k\Omega$	12.0	13.0		V
	$V_S = \pm 5V, 500\Omega$	3.1	3.5		V
	$V_S = \pm 2.5V, 2k\Omega$	1.3	1.7		V
I_{SUPPLY}	$V_S = \pm 15V$		250	325	μA
	$V_S = \pm 5V$		220	290	μA

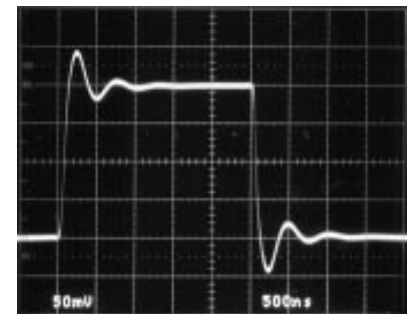

Figure 4. Small-signal step response, $A_v = -1$, $C_L = 500 pF$

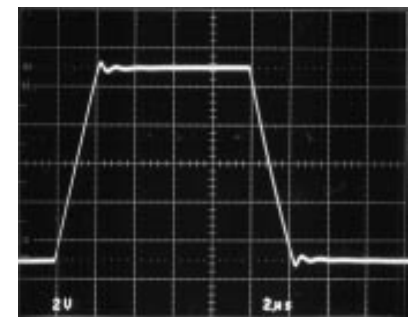

Figure 5. Large-signal step response, $A_v = 1$, $C_L = 10,000 pF$

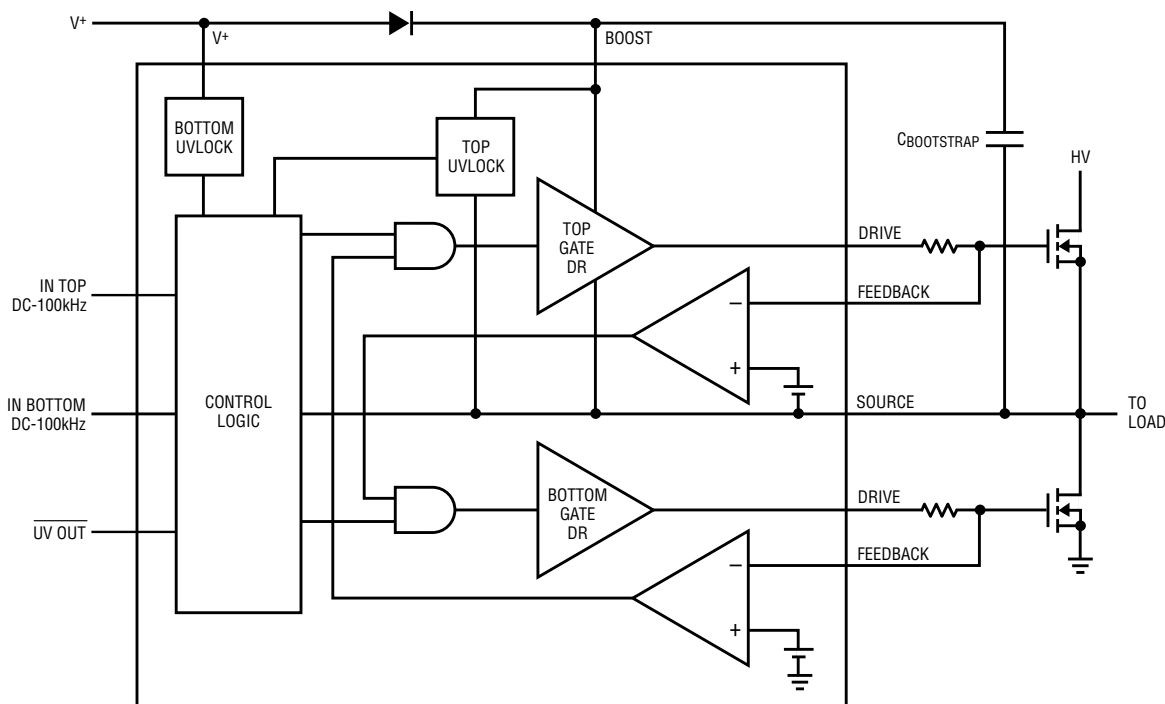

Figure 1. LT1160 block diagram with pins shown in actual package sequence

LT1160, continued from page 1

Life Above the Supply Rail

The first problem designers face in N-channel half-bridge circuits is developing the topside gate drive, which must swing at least 10V above the supply rail for standard MOSFETs. This challenge alone is so demanding that designers often resort to more expensive and less efficient P-channel MOSFETs on the topside in low voltage bridge circuits. However, even this solution is no longer straightforward when the supply voltage exceeds the maximum gate-to-source voltage (V_{GS}) rating for the MOSFET (typically 20V).

The best solution to this problem is to use a floating topside N-channel gate driver operating from a bootstrap capacitor. Although widely used, the technique of bootstrapping must be carefully implemented, since the gate voltage applied to the top MOSFET derives directly from the

voltage on the bootstrap capacitor. If this voltage becomes too low, it can cause problems for the MOSFET. For example, if at high duty cycles the output is not swinging low enough to fully recharge the capacitor, the topside gate drive will be starved, leading to overdissipation.

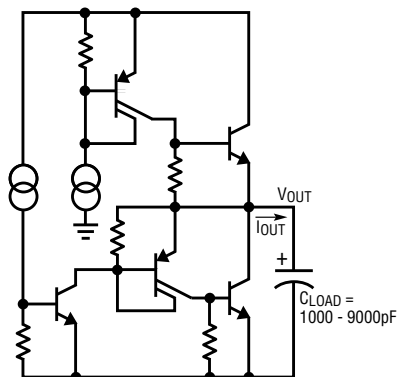

Figure 2a. Bipolar driver topology

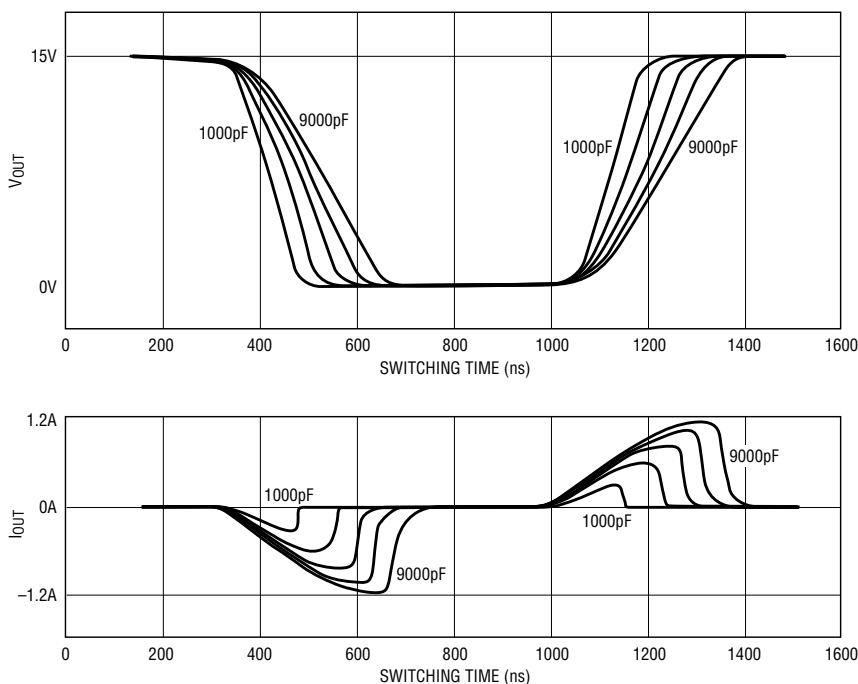

Figure 2b. Bipolar driver switching time increases only 150ns for an increase of 8,000pF in load capacitance

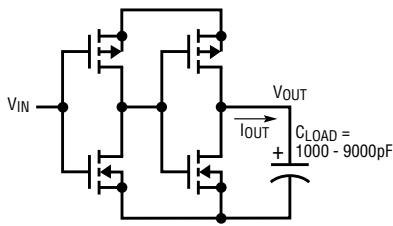

Figure 3a. CMOS driver topology

In the LT1160, a floating under-voltage detection circuit monitors the voltage across the bootstrap capacitor and a separate undervoltage detection circuit monitors the supply voltage. If, as a result of operation at high duty cycles, the voltage across the bootstrap capacitor drops below approximately 8.7V, the top driver is pulled low to prevent over-dissipating the top MOSFET, and also to allow the capacitor to be recharged. Similarly, if the supply voltage drops below about 8.3V, both drivers are pulled low to prevent over-dissipating either MOSFET. The LT1162 has separate and independent undervoltage detectors for the two half-bridge drivers.

Shoot-Through Unwelcome

Probably the most frustrating element to address in a synchronous

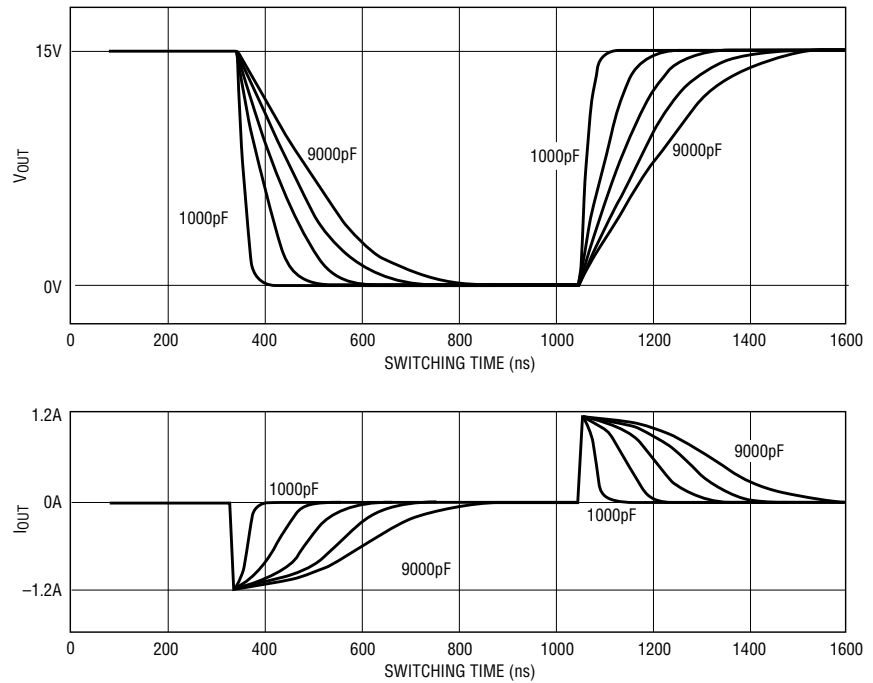
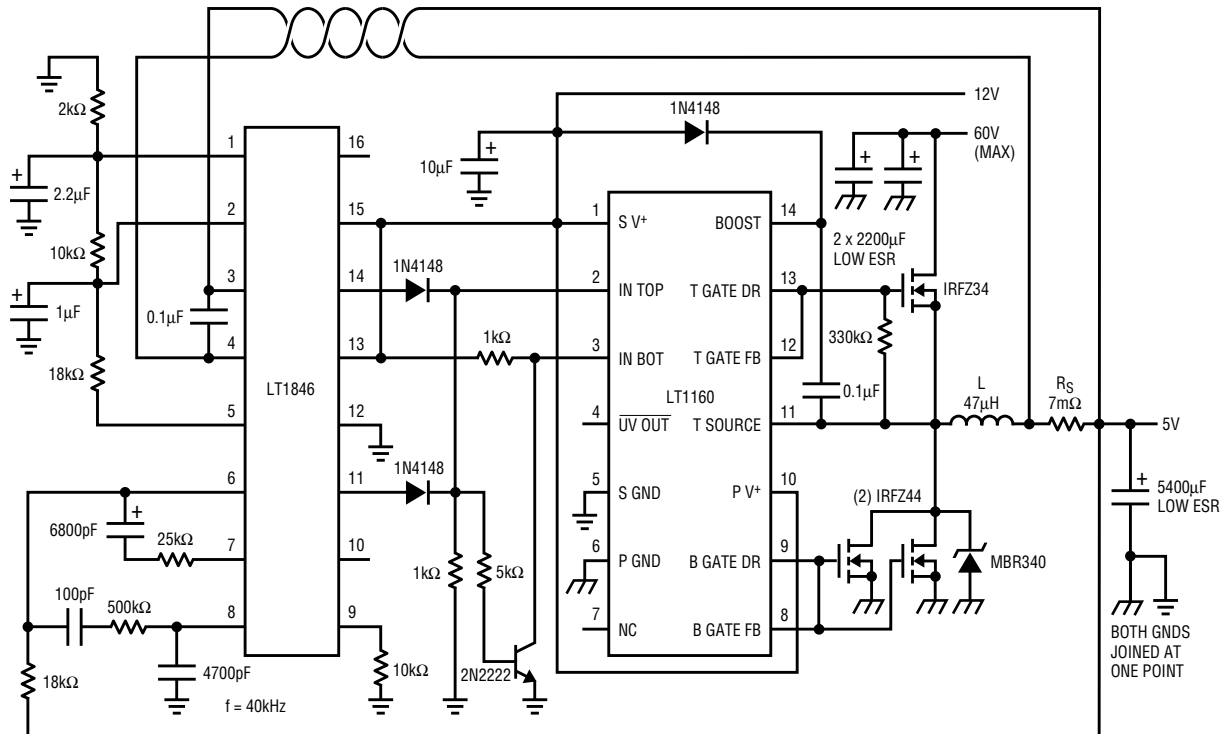

Figure 3b. CMOS driver switching time increases 400ns for an increase of 8,000pF in load capacitance

MOSFET drive circuit is the timing between the top and bottom drives to prevent cross-conduction. The presence of cross-conduction or "shoot-through" currents always saps efficiency and erodes precious thermal margins; in extreme cases it can lead to catastrophic failure.

The most common techniques rely on fixed delay times to create a dead-time between conduction of the top and bottom MOSFETs. Although this can work, the delay time must take into account temperature changes, supply variations, and production tolerances of the MOSFETs and other



L: HURRICANE LABS HL-KM147U 801 6352003
 RS: DALE TYPE LVR-3 ULTRONIX RCS01

Figure 4. 50W high efficiency switching regulator illustrates the design ease afforded by adaptive deadtime generation

components. As a result, more dead-time than is normally needed must be used, increasing the conduction time in the lossy MOSFET body diodes.

The LT1160 and LT1162 (like the LT1158) use an adaptive system that maintains dead-time independent of the type, the size and even the number of MOSFETs being driven. It does this by monitoring the MOSFET gate turn-off to see that it has fully discharged before allowing the opposite MOSFET to turn on. In this way, cross-conduction is completely eliminated as a design constraint.

The high efficiency 10A stepdown (buck) switching regulator shown in Figure 4 illustrates how different sized MOSFETs can be used without having to worry about shoot-through currents. Since 40V is being dropped down to 5V, the duty cycle for the switch (top MOSFET) is only 5/40 or 12.5%. This means that the bottom MOSFET will dominate the $R_{DS(ON)}$ efficiency losses, because it is turned on seven times as long as the top. Therefore a smaller MOSFET is used on the top, and the bottom MOSFET is doubled up, all without having to worry about dead-time. The noncritical Schottky diode across the bottom MOSFETs reduces reverse-recovery

losses. Figure 5 shows the operating efficiency for Figure 4's circuit.

Two Halves Equal a Whole

The LT1162 is functionally and electrically identical to two LT1160s. The LT1162 is ideal for motor-control applications driving an N-channel MOSFET H-bridge, as shown in Figure 6. The DC motor shown can be driven in both directions. By applying the appropriate control signals at the inputs, the motor can be made to run clockwise, counterclockwise, stop rapidly ("plugging" braking) or free run (coast) to a stop. A very rapid stop can be achieved by reversing the current, though this requires more careful design to stop the motor dead. In practice, a closed-loop control system with tachometric feedback is usually necessary.

Designing In Ruggedness

The output of a bridge circuit driving multiple-ampere inductive loads can be a very ugly signal to couple back into a hapless IC. Although MOSFETs contain integral body diodes which conduct during the dead-time, slow turn-on times and wiring inductances can result in spikes of several volts below ground

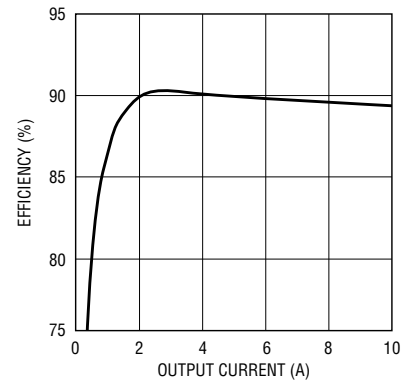

Figure 5. Operation efficiency for Figure 4's circuit. Current limit is set at 15A

or above supply. The LT1160 and LT1162 source pins have been designed to take repetitive output transients 5V outside the supply rails with no damage to the part. This saves the expense of adding high current Schottky diode clamps.

Conclusion

The LT1160 and LT1162 N-channel power MOSFET drivers anticipate all of the major pitfalls associated with the design of high efficiency bridge circuits. The designed-in ruggedness and numerous protection features make these drivers the best solution for 10V to 60V medium-to-high current synchronous switching applications. **LT**

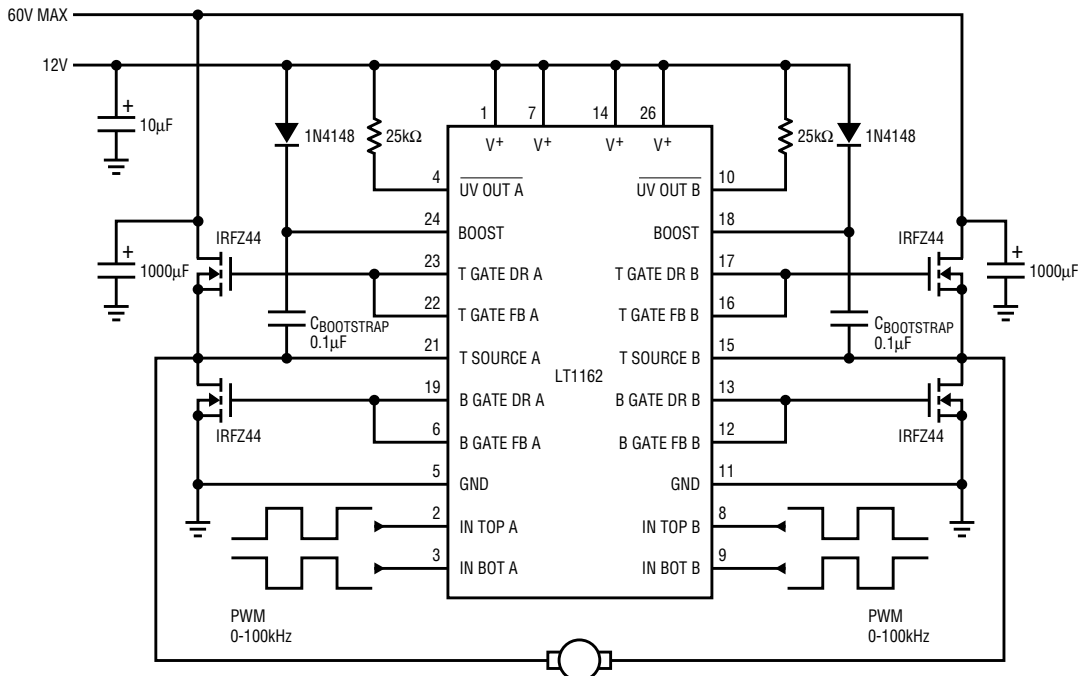

Figure 6. Full-bridge motor control with the LT1162

LTC[®]1430 Provides Efficient GTL Supply

by Craig Varga

A recent trend in computer bus architecture is the move toward GTL (Gunning Transition Logic) for routing high speed signals between the CPU and chipset logic. Buses with

speeds in excess of 66MHz are using this technology. Several different GTL supply voltage standards seem to be evolving, with voltages from 1.2V to 1.5V being discussed most often. In some implementations of the logic family, the GTL supply must both source and sink currents of 5A-10A. This causes a great deal of difficulty for a typical current mode control power supply design that is incapable of controlling currents less than zero. The LTC1430 is a voltage mode controller, and as such, does not exhibit any problems with negative load currents.

Most GTL incarnations, however, appear not to require current-sinking supplies, and the LTC1430 is well suited for these applications as well. The circuit shown in Figure 1 switches at 300kHz, regulating a 5V input down to a 1.5V output while maintaining good efficiency. (See Figure 2. Figures 2-4 are on the bottom of page 18.) Figure 3 shows the effects of a fast 4A load transient on the

1.5V output. The initial current was 1A and the final current 5A. The top trace is the output voltage (100mV/div) and the bottom trace is the regulator's inductor current (5A/div). In Figure 4, the load resistor is switched from ground to a 3V supply, resulting in bidirectional loading. Current is switched from 5A to -4A. Again, the top trace is the output of the 1.5V supply. The relatively long recovery period is actually a response to the perturbation that appears on the input voltage as a result of the large load change. Voltage mode control suffers from inherently poor line rejection. In this case, the lab supply used for the tests exhibits rather poor dynamics. If a better input supply is used, the overall settling time will be much faster. The LTC1430 also has a very accurate reference and exhibits good static load regulation, as can be seen from the very small offset between the settled light load and heavy load conditions on the output-voltage trace. 

DESIGN IDEAS...

LTC1430 Provides Efficient GTL Supply 17

Craig Varga

Battery Charger Sinks Constant Current 18

Mitchell Lee

Low Noise Charge Pump Biases GaAsFET Gates .. 19

Mitchell Lee

C-Load™ Op Amps Conquer Instabilities 20

Frank Cox and Kevin R. Hoskins

Lowpass Filters with Rail-to-Rail Input and Output ... 23

Philip Karantzalis and Jimmylee Lawson

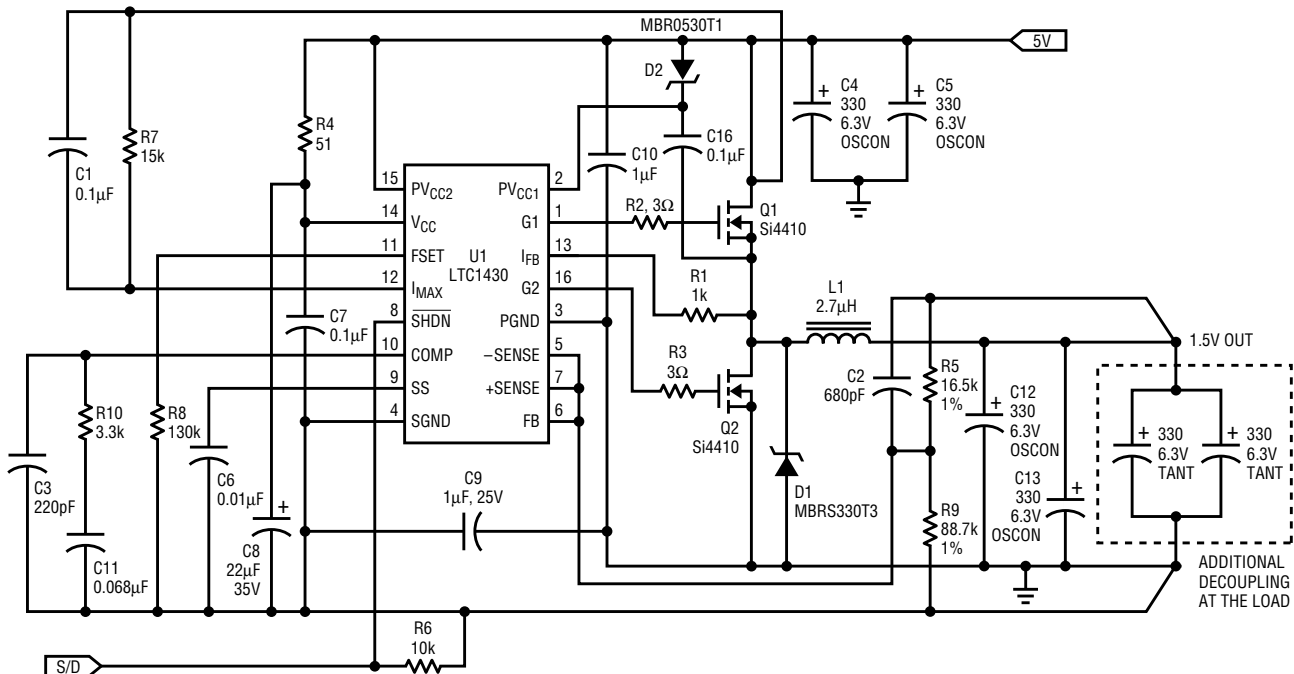

Figure 1. Schematic diagram of GTL supply

Battery Charger Sinks Constant Current

by Mitchell Lee

DC-to-DC converters make very efficient constant current sources for charging NiCd batteries. Unfortunately, the input of a switcher exhibits a negative impedance, and this can cause problems in systems where the source is power or current limited. Various schemes are used to preclude input foldback. Undervoltage lockout works well with power-limited sources, keeping the converter OFF until the input voltage has risen to the point where it can develop adequate power.

Undervoltage lockout does not work with current-limited sources. A better approach is to control the converter's input current to match

the current available from the source. The circuit shown in Figure 1 does just that, while charging 2 NiCd cells. Input current is sensed by a PNP transistor and applied as feedback to an LTC1174 stepdown converter. The Burst Mode™ converter draws just enough power to hold the input current at 50mA, matching the abilities of the wall adapter.

Output current into two cells is nominally 180mA, but climbs to over 300mA when the batteries are completely discharged. Efficiency is about 78% at 3V output. If the batteries are removed from the charging circuit, the output voltage could climb to levels destructive to the load. To

prevent this, a second feedback path is applied to Pin 1 via a diode, limiting the output voltage to approximately 3.7V.

Another condition that can spell trouble for simple circuits such as this one is the loss of input power while the batteries are still connected in circuit. An extra Schottky diode placed in series with the switch (Pin 5) blocks reverse current flow into the LTC1174 and prevents damage. The output can also be short circuited without damage to the device. Shutdown (Pin 8) allows logic control of the charger, so the charging current can be interrupted without disconnecting the source supply. ◀

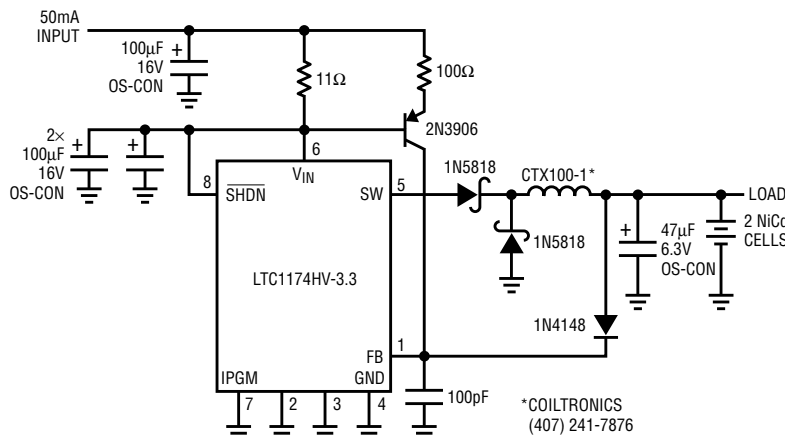

Figure 1. Schematic diagram of constant-current battery charger

Authors can be contacted at (408) 432-1900

LTC1430, continued from page 17

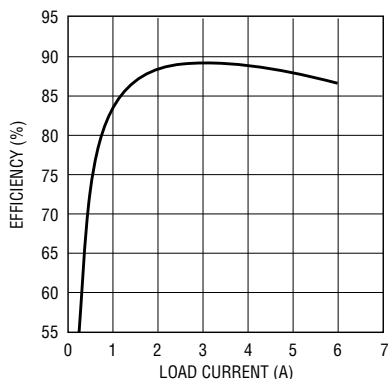

Figure 2. Efficiency plot of the GTL supply

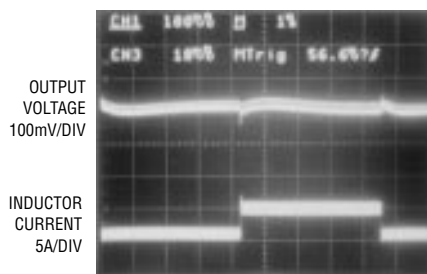

Figure 3. Oscilloscope showing effects of 4A load step on the 1.5V output



Figure 4. Oscilloscope showing effects of bidirectional loading on the GTL supply

Low Noise Charge Pump Biases GaAsFET Gates

by Mitchell Lee

Gallium arsenide MOSFETs are widely used in wireless applications as RF output amplifiers, especially in cellular telephones. Although they provide excellent power gain, output power and efficiency on low voltage battery supplies, GaAsFETs are depletion-mode devices and require a negative gate voltage for proper bias. Since only a small current (less than 10mA) is required, a charge pump is the best solution for generating a negative gate-bias supply.

Charge pumps normally conjure visions of noise, and rightly so. Their very operation relies on transferring energy from input to output by alternately charging and discharging a transfer capacitor—a decidedly noisy process. Noise on the gate-bias line translates directly to the output spec-

tra, rendering the usual charge pump unsuitable for this application.

A new generation of charge pumps with on-chip post regulators has been developed to satisfy this application. Although the charge pump is retained as the most economical and compact method of generating a negative voltage from a positive input, a linear post regulator is added to “purify” the otherwise noisy charge-pump output. The result is a negative bias supply so quiet you’ll need to build a low noise preamp in order to observe the noise on a spectrum analyzer.

Figure 1 shows the LTC1550 low noise, regulated, switched-capacitor voltage inverter. Total noise over a 40MHz bandwidth is approximately $200\mu\text{V}_{\text{RMS}}$ with a 1mA load. Compare this with 10–100mV_{RMS} noise, a fig-

ure more typical of generic charge pumps. A plot of spot noise is shown in Figure 2. Above 20kHz, broadband output noise is gradually eliminated by the 10 μF output capacitor. Throughout the audio range the noise is 600–700nV/ $\sqrt{\text{Hz}}$.

Figure 3 shows the spectral response of the LTC1550 over a range of 100kHz to 10MHz. Switching noise at 900kHz and related harmonics are less than 10 μV . The ferrite bead used during these tests attenuates harmonics above 5MHz. Depending on the application, a series resistor of 1 Ω to 10 Ω may be just as effective at attenuating noise.

The LTC1550 is part of a larger family of devices including multiple versions and the LTC1551. The only difference between the LTC1550 and LTC1551 is shutdown polarity (the LTC1550 has inverting shutdown, and the LTC1551 has noninverting shutdown). Packages with higher pin counts include features such as adjustable output and a “power good” pin for controlling power to the GaAsFET drain. All devices exhibit the same characteristic low output noise. See the LTC1550/LTC1551 data sheet for a complete description of all available options. 

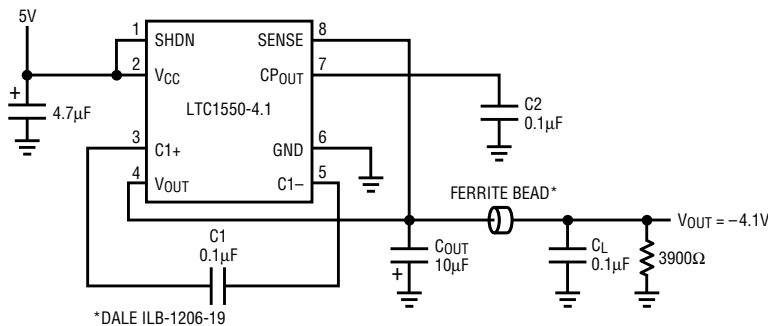

Figure 1. Circuit diagram: LTC1550 low noise, regulated, switched-capacitor voltage inverter

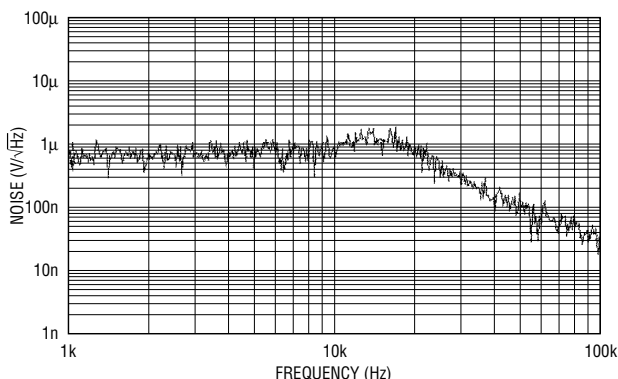

Figure 2. Spot noise plot of the circuit shown in Figure 1

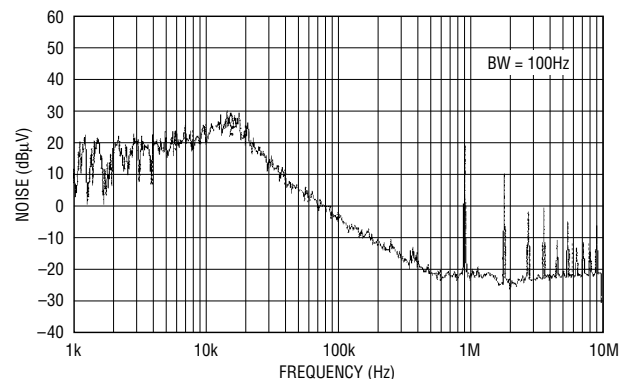

Figure 3. Spectral response of the LTC1550, 100kHz to 10MHz

C-Load™ Op Amps Conquer Instabilities

by Frank Cox and Kevin R. Hoskins

Introduction

LTC has taken advantage of process technology advances and circuit innovations to create a series of C-Load operational amplifiers. All of these amplifiers are tolerant of capacitive loading, and a majority of them remain stable driving any capacitive load. This series of amplifiers has a bandwidth that ranges from 160kHz to 140MHz. These amplifiers are appropriate for a wide range of applications such as coaxial cable drivers, video amplifiers, analog-to-digital converter (ADC) input buffer/amplifiers and digital-to-analog converter (DAC) output amplifiers.

This article looks at a few of the many applications for which the C-Load amplifiers are appropriate, including overcoming the large junction capacitance of surge protection diodes on the outputs of video amplifiers, driving the dynamically changing capacitive loads of high speed ADC converters' analog inputs, and driving an ADC's reference with varying voltages.

Table 1 lists LTC's unconditionally stable voltage-feedback C-Load amplifiers. Table 2 lists other voltage-feedback C-Load amplifiers that are stable with loads up to 10,000pF.

Video Performance with ESD Protection

The circuit shown in Figure 1 is a simple gain-of-2 line driver that is capable of withstanding high levels of electrostatic discharge (ESD) while retaining its excellent video performance. The output of the LT1363 amplifier is protected with transient voltage suppressors. These suppressors are Zener diodes designed for circuit protection and specified for high peak power dissipation, stand-off voltage and maximum surge current. The P6KE15A diodes used in this circuit have a peak power dissipation of 600W, a minimum stand-off voltage of 12.8V and a maximum surge current of 28A. This presents an extraordinary level of protection for the output of the amplifier, but the large junction diodes present a problem for some video circuits.

The series connection of the two P6KE15A diodes has 500pF of total capacitance in the OFF state (the normal operating condition).

Normally, large capacitive loads are to be avoided in video amplifiers. Not only can capacitive loading cause oscillation in amplifiers that are not designed for it, but the limited output

Table 1. Unity-gain stable C-Load amplifiers stable with all capacitive loads

Singles	Duals	Quads	GBW (MHz)	I _S /Amp (mA)
—	LT1368	LT1369	0.16	0.375
LT1200	LT1201	LT1202	11	1
LT1220	—	—	45	8
LT1224	LT1208	LT1209	45	7
LT1354	LT1355	LT1356	12	1
LT1357	LT1358	LT1359	25	2
LT1360	LT1361	LT1362	50	4
LT1363	LT1364	LT1365	70	6

Table 2. Unity-gain stable C-Load amplifiers stable with C_L ≤ 10,000pF

Singles	Duals	Quads	GBW (MHz)	I _S /Amp (mA)
LT1012	—	—	0.6	0.4
—	LT1112	LT1114	0.65	0.32
LT1097	—	—	0.7	0.35
—	LT1457	—	2	1.6

current of many amplifiers causes slew limiting. The excellent output drive (70mA minimum at ±15V supplies) and the C-Load stability features of the LT1363 make the video performance of this circuit almost indistinguishable from the same driver without the added ESD protection. Of course, the 75Ω series matching resistor on the output helps to isolate the capacitive load. For the best high speed performance, we recommend that the coax cable be matched in this way. However, there are cases where the maximum output swing is required and this resistor cannot be used (of course, for quality video a termination resistor is always used on the end of the cable), so tests were run with composite video to quantify the effect of this component. Table 3 gives differential gain and phase measurements for the amplifier circuit with and without the output series resistor.

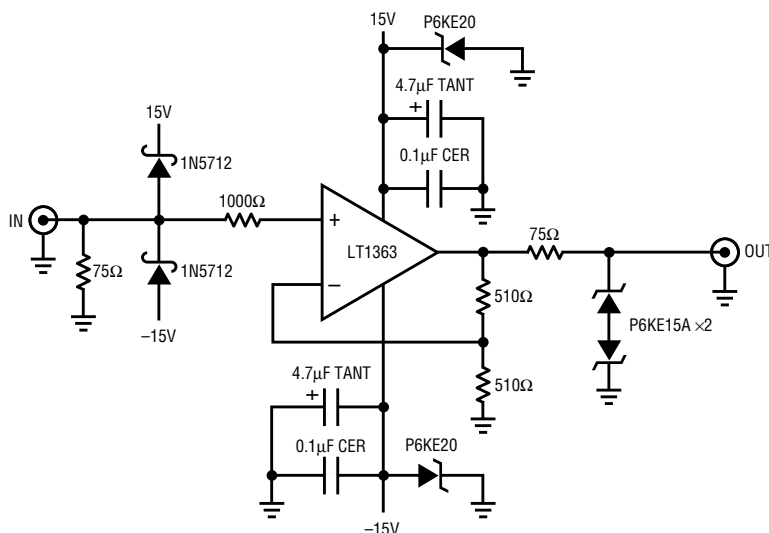

Figure 1. Line driver circuit diagram

Table 3. Differential gain and phase measurement summary

	Differential Phase	Differential Gain
LT1363 with output clamp and 75Ω output R	0.11°	0.03%
LT1363 with output clamp and no R	0.11°	0.3%
LT1206 with output clamp and 75Ω output R	0.1°	0.1%
LT1206 with output clamp and no R	0.11°	0.1%

Except for a slight rise in the LT1363's differential phase, there is no measurable degradation. The output and power supply pins of the driver circuit withstand repeated air discharges of 17kV (the limit of the test equipment) without failure. The input is sensitive to the loading effects of the diode and resistor network because the junction capacitance of the clamp diodes works against the impedance of the cable-termination resistors. For this reason, low capacitance clamp diodes were used. The input of the driver circuit still stood off 10kV. If some reduction in the frequency response (approximately 3dB at 5MHz) can be tolerated, the network shown in Figure 2 can be added to the input to increase the standoff voltage to 17kV.

For even more demanding applications, we recommend the driver circuit

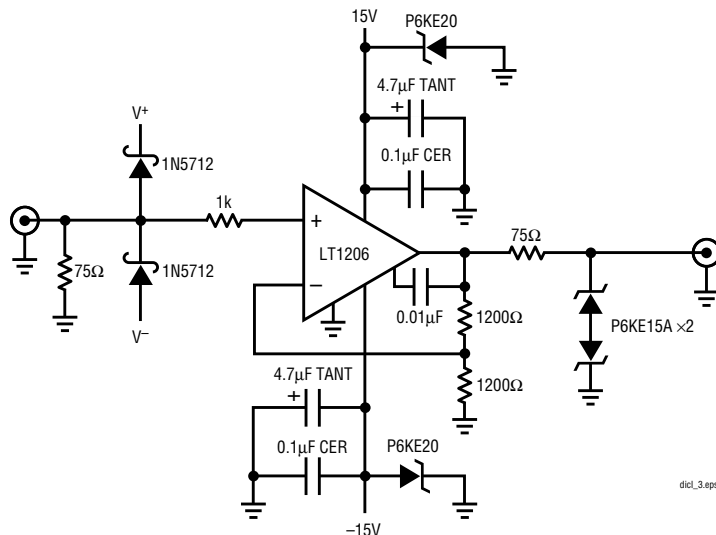

Figure 3. 250mA output line driver

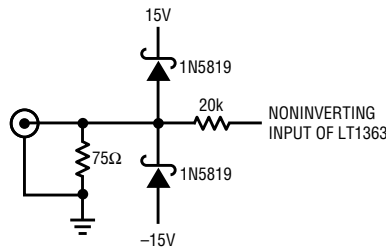

Figure 2. Circuit with modified clamp for higher voltage

of Figure 3. The LT1206 high current CFA has no measurable performance degradation for video signals with the suppressor diodes on the output, although the restriction of the input-clamp network still holds. The 250mA output drive (over 0°C to 70°C temperature with ±5V to ±15V supplies) capability and the C-Load feature of the LT1206 make it a natural for driving difficult loads.

Driving ADCs

Most contemporary analog-to-digital converters (ADCs) incorporate a sample-and-hold (S/H) using a topology exemplified by the circuit in Figure 4. The hold capacitor's (C1) size varies with the ADC's resolution, but is generally in the range of 5pF–20pF, 10pF–30pF or 10pF–50pF for 8-, 10- or 12-bit ADCs, respectively.

At the beginning of a conversion cycle, this circuit samples the applied signal's voltage magnitude and stores it on its hold capacitor. Each time the switch opens or closes, the amplifier driving the S/H's input faces a

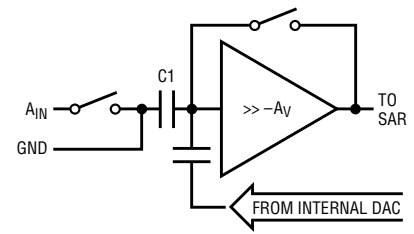

Figure 4. Typical ADC input stage showing input capacitors

dynamically changing capacitive load. This condition generates current spikes on the input signal. These spikes, along with the capacitive load, are a very challenging load that can potentially produce instabilities in an amplifier driving the ADC's input. These instabilities make it difficult for an amplifier to settle quickly. If the output of an amplifier has not settled to a value that falls within the error band of the ADC, conversion errors can result. That is, unless the amplifier is designed to gracefully and accurately drive capacitive loads, as are Linear Technology's C-Load line of monolithic amplifiers.

As can be seen in Figure 5a, an amplifier whose design is not optimized for handling large capacitive loads has some trouble driving the hold capacitor of the LTC1410's S/H. Although the LT1006 has other very

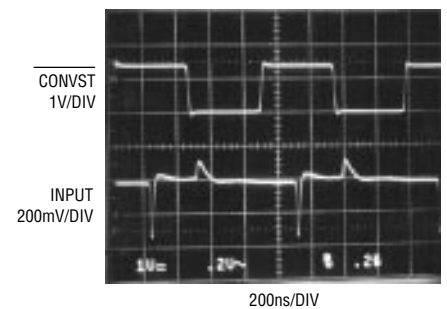

Figure 5a. Input signal applied to an LTC1410 driven by an LT1006

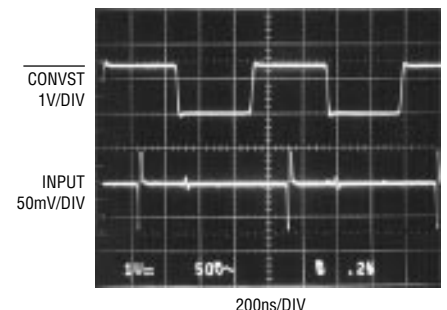

Figure 5b. Input signal applied to an LTC1410 driven by an LT1363

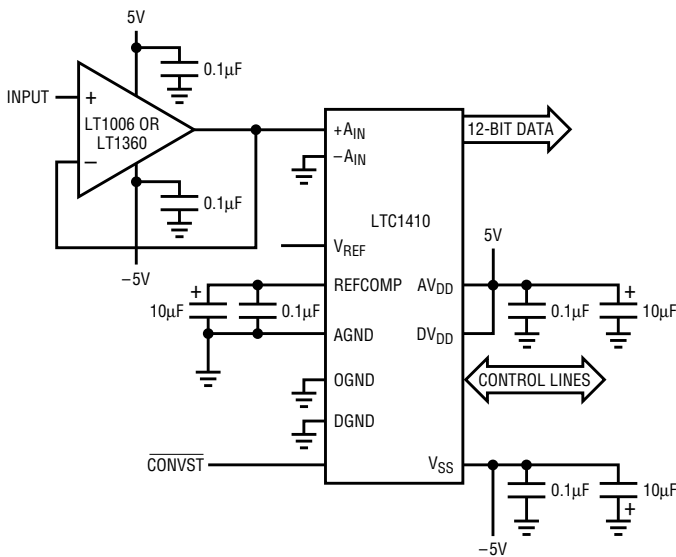

Figure 6. Test circuit used to measure LTC1410 input signal waveform

shows that the LTC1360 is an ideal solution for driving the ADC's input capacitor quickly and cleanly with excellent stability. Its wide 50MHz gain bandwidth and 800V/µs slew rate very adequately complement the LTC1410's 20MHz full-power bandwidth. The LTC1360 is specified for ±5V operation.

Figure 6 shows the circuit used to test the performance of op amps driving the LTC1410's input and measure the ADC's input waveforms.

Adjustable ADC Reference Voltage

An ADC's reference voltage should always be set to a value that maximizes the number of codes generated during input signal conversion. If the reference voltage is set for input signals with the widest full-scale range, this might be too large for input signals with a much smaller range. For example, an ADC's full-scale input

continued on page 25

desirable characteristics, such as low V_{OS} , high slew rate and low power dissipation, it has difficulty accurately responding to dynamically changing capacitive loads and the current glitches and transients they produce,

as indicated by the instabilities that appear in the lower oscilloscope trace in Figure 5a.

By contrast, Figure 5b shows the LTC1360 C-Load op amp driving the same LTC1410 input. The photo

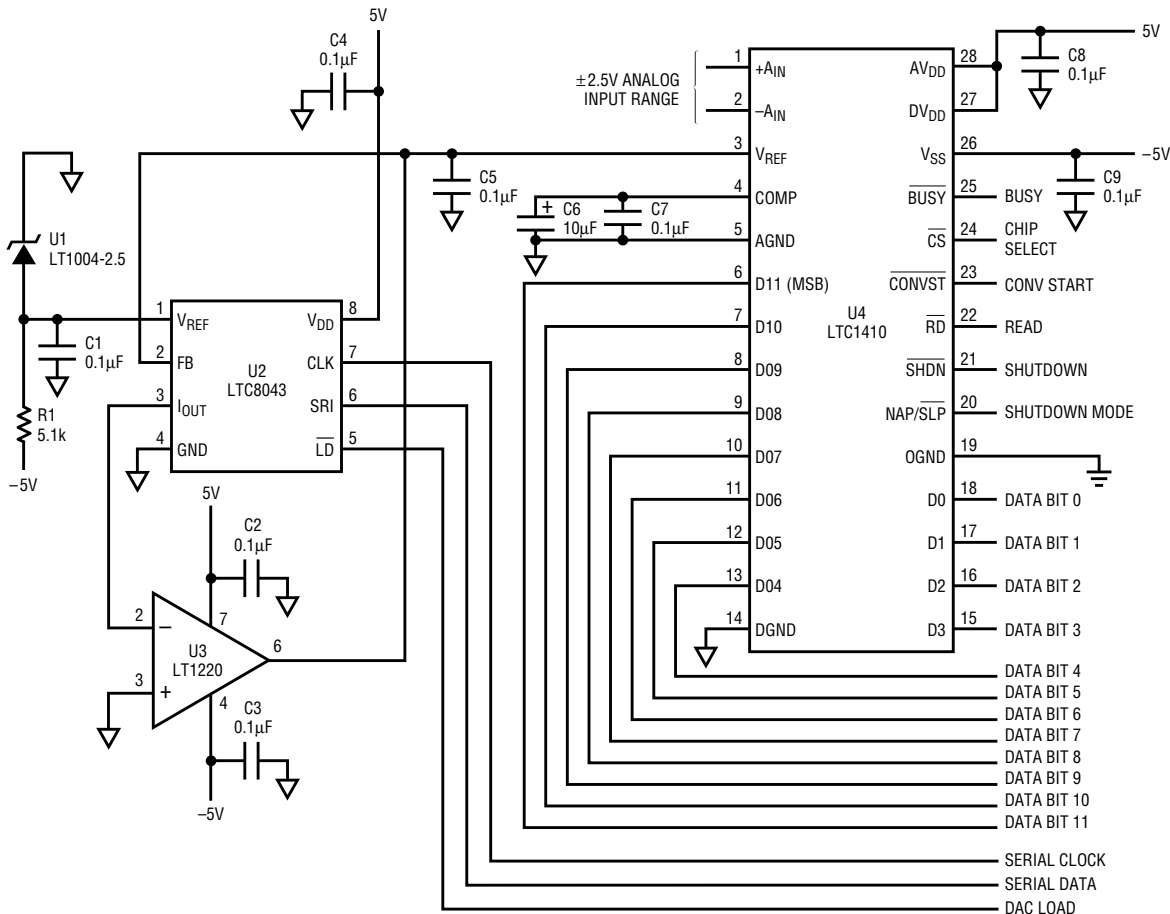

Figure 7. The 12-bit LTC8043 DAC and the C-Load LT1220 op amp create variable reference voltages, enhancing the 12-bit LTC1410 ADC's input range flexibility

Lowpass Filters with Rail-to-Rail Input and Output

by Philip Karantzalis and Jimmylee Lawson

The proliferation of systems operating exclusively with single 5V supplies has created a need for analog signal conditioning circuits with rail-to-rail input and output. Op amps, A/D converters, and D/A converters with rail-to-rail inputs and outputs are readily available, but not high-order lowpass filters. High-order lowpass filters are used to provide antialiasing protection for A/D converters or to bandlimit the outputs of D/A converters.

Rail-to-Rail, DC-Accurate, Butterworth and Bessel 7th-Order Lowpass Filters.

The circuit of Figure 1 uses a dual rail-to-rail op amp and a DC-accurate switched-capacitor filter to provide a 7th-order lowpass filter. The rail-to-rail op amps accommodate the nonrail-to-rail output operation of the switched capacitor filter. Overall rail-to-rail operation is achieved by attenuating and level shifting the input signal and by level shifting and amplifying the output of the switched-capacitor filter.

The circuit of Figure 1 operates with a single 5V supply and attenuates the input signal by a factor of two. A 0-to-5V_{P-P} input signal appears as 1.25-3.75V at the input of the filter. The attenuation factor of two is chosen as a convenient number, and does not fully exploit the 3.5V output-voltage range of the switched-capacitor filter. The penalty is a mere 2dB loss of signal-to-noise ratio, yet the circuit is still usable for 12- to 13-bit applications.

The input op amp of Figure 1 provides buffering. A single pole antialiasing filter is added in front of the switched capacitor filter through capacitor C3; its cutoff frequency is 3.3 times the cutoff frequency of the switched-capacitor filter.

The output op amp of Figure 1 provides an additional 2-pole, continuous-time filter and restores the rail-to-rail output swing. Table 1 shows the component values of Figure 1 for three different cutoff frequencies. The passive components were carefully selected to work for both filter types, Butterworth and Bessel.

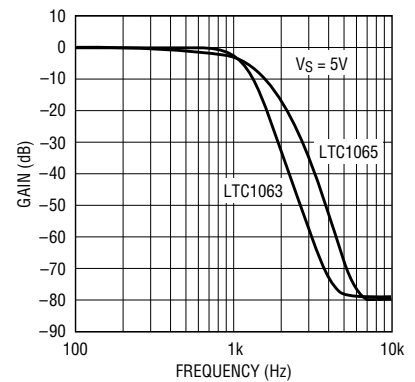

Figure 2. Amplitude response of Figure 1's circuit for both LTC1063 and LTC1065

Other cutoff frequencies can be obtained by scaling the component values of Table 1. The 7th-order amplitude response of the circuit is shown in Figure 2. Figure 2 was traced with a 1.7V_{RMS} input (4.76V_{P-P}), and the measurement bandwidth was 22kHz. The filter cutoff frequency was set to 1kHz. Attenuation as high as 80dB is obtained with the linear-phase LTC1065 filter. Figure 3 shows the dynamic range (S/N + THD) of the filter of Figure 1.

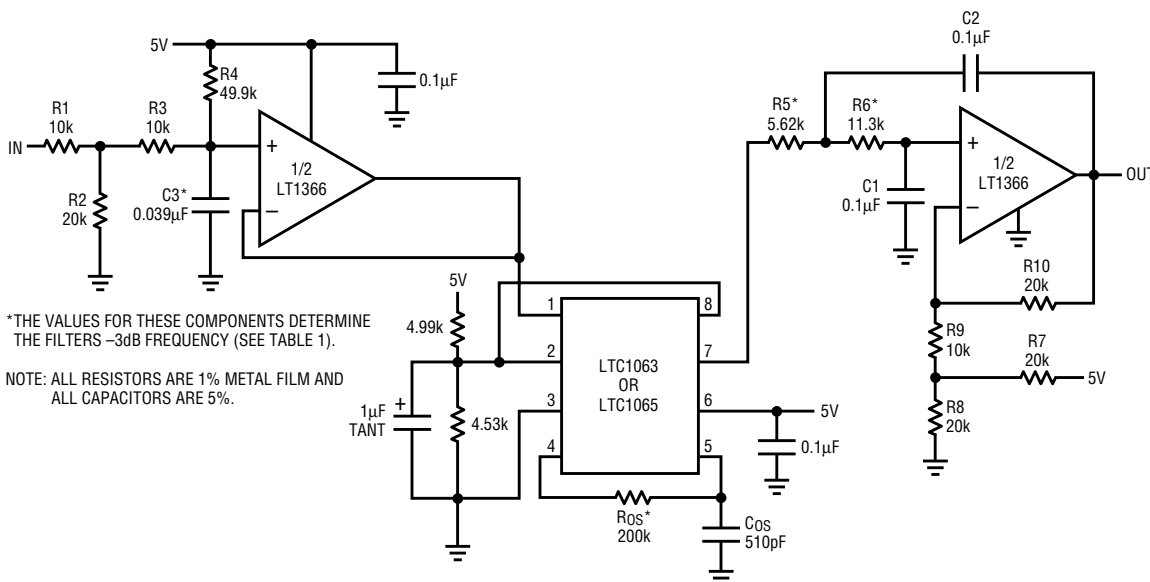

Figure 1. 100Hz 7th-Order Butterworth or Bessel lowpass filter with rail-to-rail input and output

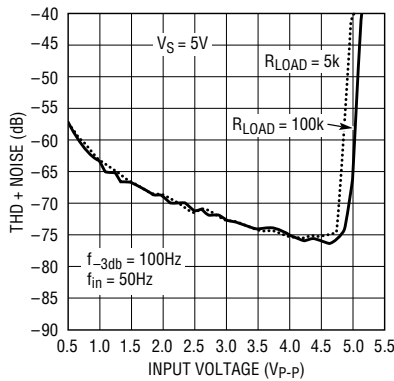

Figure 3. Dynamic range (THD + Noise) versus input voltage plot for the circuit of Figure 1

The 76dB maximum dynamic range occurs around $4.75V_{p-p}$ and this should be the full scale of the system. Figure 4 shows the transient response of both Butterworth and Bessel 7th-order filters.

The measured DC gain error of Figure 1's circuit is less than 0.5%. This depends on the matching of resistors R1-R4 and R7-R10. The measured DC gain nonlinearity of this circuit is $\leq 0.1\%$ (-80dB).

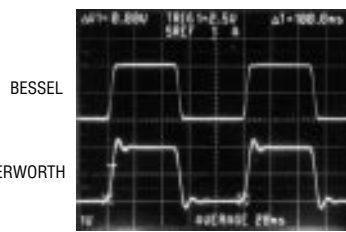

Figure 4. Oscilloscope of square wave response; top trace is the LTC1065 Bessel filter, bottom trace is the LTC1063 Butterworth filter

20Hz Rail-to-Rail Linear-Phase Lowpass Filter with 60Hz Notch.

The circuit of Figure 5 is a 20Hz Bessel filter with an additional 60Hz notch. This type of circuit is useful in applications where excessive 60Hz noise is present and, on top of bandlimiting, additional attenuation of 60Hz is required. The same scheme of rail-to-rail op amps is used for input and output buffering, except the output of the first op amp is fed forward to the input of the Sallen-Key lowpass filter. The output of the

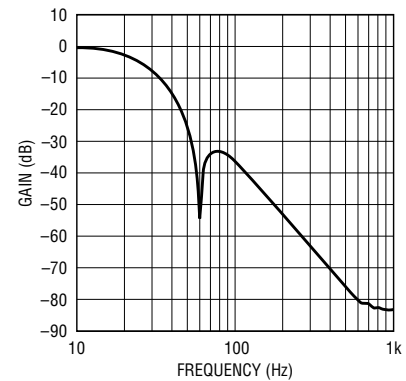

Figure 6. Amplitude response of the circuit detailed in Figure 5

LTC1065 is connected to the noninverting input of the Sallen-Key filter through R11. When the output of the first op amp is 180 degrees out of phase from the output of the LTC1065, a notch depth of 50dB or greater can be achieved. In order to achieve this notch depth for 60Hz, the resistors R5, R6, R11 and R_{OS} must be 0.1% and the C_{OS} capacitor must be 1% tolerance. Figure 6 shows the gain response of the circuit in Figure 5. \blacktriangleleft

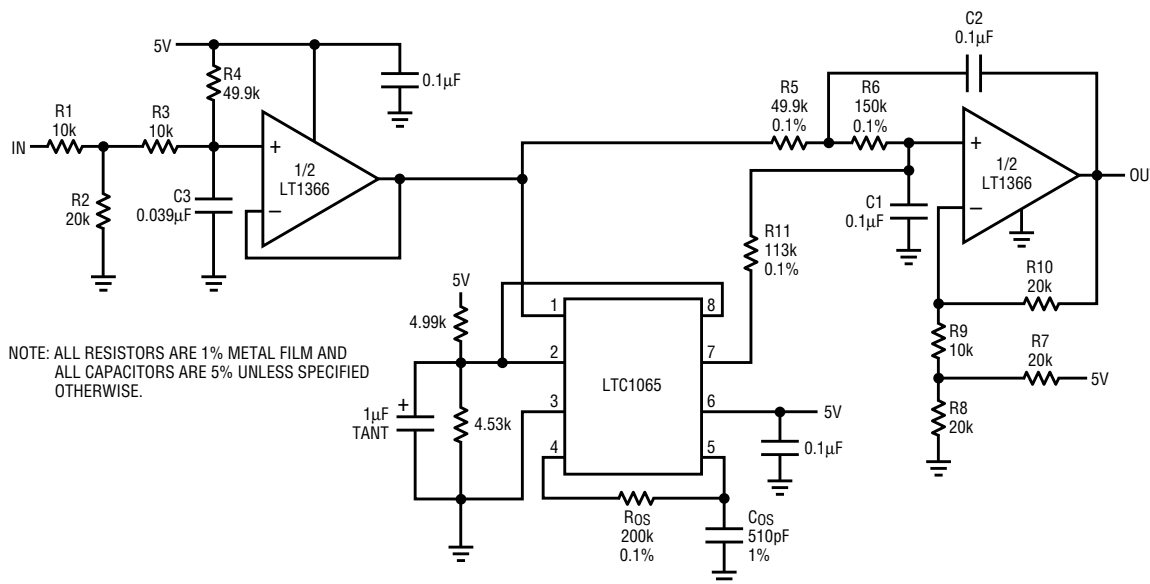

Figure 5. Schematic diagram of 20Hz Bessel lowpass filter with 60Hz notch

Table 1. Component values for Figure 1's circuit for three different cutoff frequencies

-3dB Freq	C3	R_{OS}	C_{OS}	R5	R6
10Hz	0.39 μ F	2M	510pF	56.2k	113k
100Hz	0.039 μ F	200k	510pF	5.62k	11.3k
1kHz	0.0039 μ F	19.1k	510pF	562 Ω	1.13k

C-load, continued from page 22

span is set to 5V. Input signals with magnitudes that cover this span will use all of the ADC's codes. However, an input signal that only spans 2V will use only 2/5 of the codes, resulting in a loss of resolution. When the reference voltage is reduced to 2V, the 2V signal will now use all of the ADC's codes. But with the 2V reference, an input signal having a 4V span is likely to exceed the input span, resulting in clipped signals and missed information. In cases such as this, an adjustable reference is needed to adjust the ADC's full-scale gain.

The circuit in Figure 7 uses the LTC8043 12-bit CMOS 4-quadrant DAC driving the LT1220 C-Load amplifier to generate variable ADC reference voltages that allow the user to adjust the ADC's gain. An LT1004-2.5 micropower 2.5V reference is used as the LTC8043's reference source, setting its output span to 0V-2.5V. The LT1220's output is applied to the LTC1410's V_{REF} input. The LT1220 C-Load amplifier ensures that, when changing the LTC1410's reference voltage, the amplifier does not oscillate even while driving the reference

input bypass capacitor C5. The LTC1410 can easily handle a reference voltage as low as 1V ($\pm 2V_{P-P}$ input range) with only a 0.5 LSB change in linearity error.

Conclusion

Using advanced process technology and innovative circuit design, LTC has created a series of C-Load operational amplifiers that not only tolerate capacitive loading, but remain stable driving any capacitive load. C-Load amplifiers meet the challenging and difficult capacitive loads by remaining stable and settling quickly. **LT**

PFC, continued from page 11 (Design Features)

Conclusion

PFC is fun. It offers technical challenges not because it is complicated but because there are so many little weirdnesses, all happening together in concert to provide a beautiful function. One of the biggest challenges is to find a place to hook your scope

probe to see the PFC in action. Scope probes don't read duty factor very well, and probing on the FET drain reveals a waveform that doesn't look like anything you have ever seen before, and may awaken you in the middle of the night. It's not that the

waveform isn't pretty, it's that the waveform is very busy, and it is hard to see anything like a sine wave in it. The input current waveform is far easier to enjoy, it's just harder to get to without a good current probe. **LT**

Authors can be contacted at (408) 432-1900

Index of Circuits in *Linear Technology*, Issues I:1 Through V:4

Included with this issue is a complete index of the circuits featured in *Linear Technology Magazine*, issues I:1 through V:4. This index evolved as a result of a request from one of our Field Applications Engineers, who was unable to locate a circuit he believed had appeared in *Linear Technology Magazine*. We set out

to create an index in which the reader could "browse" for a circuit that fit his or her design needs or search for a specific *Linear Technology* part; we believe that the table design we used here thoroughly fulfills this mission. The reader can page to the desired circuit category, scan the columns for the circuit type and/or part

number, and easily find the appropriate article, issue, page number, and figure number(s).

Over 250 circuits from the first five years of *Linear Technology* magazine are included in this index. Hereafter, we will update the index yearly, so new circuits won't get lost. Pleasant Reading! **LT**

New Device Cameos

LTC1409 and LTC1415: High Speed, Low Power, 12-bit A/D Converters

LTC has two new 12-bit A/D converters that set a new standard for high performance at low power. The LTC1415 is a 12-bit, 1.2Msps A/D converter that operates on a single 5V supply and draws just 60mW of power. The LTC1409 is a 12-bit, 800ksps A/D converter with outstanding dynamic performance (SINAD = 71dB at Nyquist) that operates on a $\pm 5V$ supply.

The LTC1409 and LTC1415 both have differential input sample-and-hold circuits that reduce unwanted high frequency common mode noise. The LTC1415 has a unipolar input range of 0V to 4.096V (1mV per LSB). The LTC1409 has a bipolar input range of $\pm 2.5V$. The input ranges of both devices are set with an on-chip 2.5V precision voltage reference.

Both devices have parallel output interfaces that allow easy connection to microprocessors, DSPs or FIFOs. Two power-shutdown modes allow flexibility in further reducing the power during inactive periods. Both devices come in 28-pin SO packages.

The LTC1446/LTC1447: World's Only Dual 12-Bit, Rail-to-Rail DACs in SO-8 Packages

The LTC1446 and LTC1447 are complete dual, 12-bit micropower DACs with rail-to-rail buffer amplifiers and an onboard reference. Both parts have a maximum DNL error of 0.5LSB. They have an easy-to-use cascadable serial interface that is SPI compatible. Applications for these parts include industrial process control, digital calibration, automatic test equipment, cellular telephones and portable battery-powered applications where low supply current is essential.

The LTC1446 operates on a single supply ranging from 2.7V to 5.5V, dissipating a mere 1.35mW from a 3V

supply. It has a wide output swing of 0V to 2.5V. The LTC1447 operates on a single supply of 4.5V to 5.5V, dissipating 3.5mW. It has an output swing of 0V to 4.095V. Both parts have an onboard reference that is connected internally to each DAC. A D_{OUT} pin allows several parts to be daisy-chained, and a built-in power-on reset clears the output to zero-scale at power-up.

Both the LTC1446 and the LTC1447 come in an SO-8 package or a small 8-pin PDIP, allowing efficient use of circuit board space. These dual DACs offer excellent DNL, low power and a convenient serial interface, all in a tiny SO-8 package.

LT1464: First Micropower JFET Op Amp for Driving C-Loads

The LT1464 op amp combines features that would normally be unique to three different types of op amps. The LT1464 is the first micropower JFET op amp in our C-Load family of op amps. The output can drive capacitive loads up to 10nF with any load resistance. At the input side of the op amp, input bias currents are less than 1pA for demanding track-and-hold circuits and active filters that use high-value resistors. Input common mode range includes the positive supply. Power supply current is typically 250 μ A, allowing micropowered battery applications. For single supply requirements, a full set of specifications are included for 5V operation. The slew rate is 1V/ μ s and the gain bandwidth is 1MHz.

The LTC1458 and LTC1459: Quad 12-Bit, Rail-to-Rail Micropower DACs

The LTC1458 and the LTC1459 are complete quad 12-bit micropower DACs with rail-to-rail buffer amplifiers and an onboard reference. Both of

these parts have a maximum DNL error of 0.5LSB, and an easy-to-use, SPI compatible, cascadable serial interface. They also offer several convenient features that make these parts flexible and easy to use. Industrial process control, automatic test equipment and digital calibration are just a few of the applications for these parts.

The LTC1458 operates on a single supply ranging from 2.7V to 5.5V and dissipates a mere 2.5mW from a 3V supply. It has a 1.22V onboard reference. The LTC1459 operates on a single supply of 4.5V to 5.5V, dissipating 6mW. Its onboard reference is 2.048V. Both of these parts have a separate reference input pin for each DAC, which can be driven by an external reference or connected to the onboard reference output. The user can also offset the zero-scale voltage for each DAC by means of a REF_{LO} pin. Each of the rail-to-rail buffer amplifiers will swing to within a few millivolts of either supply rail and can be connected in a gain-of-one or a gain-of-two configuration, giving an output full-scale of $1 \times REF_{IN}$ or $2 \times REF_{IN}$ respectively. There is a built-in power on reset and a CLR pin that resets the output to zero-scale.

Both the LTC1458 and the LTC1459 come in small 28-pin SSOP or 28-pin SO packages. These quad DACs offer the user flexibility with a host of useful features, excellent DNL and low power dissipation.

LT1537 5V Powered RS232 Transceiver

The LT1537 is a new three-driver/five-receiver RS232 interface transceiver designed to serve as a serial I/O port for AT-compatible computers. The LT1537 is pin compatible with the LT1137A. Its integral charge-pump power generator uses low cost 0.1 μ F and 0.2 μ F capacitors to

generate RS232 levels from standard 5V power supplies. The device has low power consumption: 8mA in normal operation and 1 μ A in shutdown mode.

The LT1537 is RS232/RS562 standard compatible. Operation at data rates in excess of 250kBd for 1,000pF loads and 120kBd for 2,500pF loads is guaranteed. Slew rate with 3k Ω , 2500pF loads is a minimum of 4V/ μ s. When powered down or in shutdown mode, the driver outputs remain high impedance for line voltages to 15V. Both driver outputs and receiver inputs can be forced to \pm 25V without damage.

Whereas most other RS232 transceivers require external ESD protection devices, the LT1537 is protected against \pm 5kV ESD strikes to the RS232 inputs and outputs. This integrated ESD protection saves the expense and space of external protection devices. This level of ESD protection is adequate in most applications. In applications where high ESD level protection (IEC-801-2) is required, our LT1137A provides that solution. The LT1537 is available in 28-lead SO and SSOP packages.

The LTC1449/1450 Parallel Input, 12-Bit Rail-to-Rail Voltage Output Micropower DACs

The LTC1449 and LTC1450 are LTC's first pair of parallel-input, voltage output DACs. These devices are designed as complete DACs with internal references and buffered, true rail-to-rail voltage outputs. The analog specifications are equivalent to those of the LTC1451 serial DAC, with excellent DNL performance of less than \pm 0.5LSBs.

The buffered true rail-to-rail voltage output can be configured for two different full-scale settings. When the internal reference is used and the gain-setting pin is tied to ground, the full-scale range is 2.500V for the LTC1449 and 4.095V for the LTC1450. When the gain-setting pin is connected to V_{OUT} , the full-scale ranges

change to 1.220V for the LTC1449 and 2.047V for the LTC1450.

The LTC1449 and LTC1450 are designed to run off a single supply while consuming very little power. The LTC1449 can be powered from a single supply as low as 2.7V; when powered from such a supply, it dissipates only 0.75mW. The LTC1450 is powered from a single 5V supply and dissipates only 2mW of power. This low power dissipation makes the LTC1449 and LTC1450 ideal for battery-powered applications.

Separate pins are provided for both ends of the voltage-scaling resistor network to allow for versatile connection in multiplying and external-reference applications. Double-buffered parallel digital inputs provide flexibility and easy interface to popular DSPs and microprocessors.

The LTC1449 and LTC1450 are available in 24-lead PDIP and SSOP packages.

The LTC1516: Micropower, Regulated, 5V Charge-Pump DC/DC Converter

The LTC1516 is a micropower charge-pump DC/DC converter that generates a regulated 5V output from a 2V to 5V supply, without inductors. Only four external capacitors (two 0.22 μ F and two 10 μ F) are required to deliver a 5V \pm 4% output with up to 50mA of output load current. Extremely low supply current (12 μ A typical with no load and less than 1 μ A in shutdown conditions) and low external parts count make the LTC1516 ideal for small, battery-powered applications. The LTC1516 achieves efficiency greater than 75% with load currents as low as 100 μ A, due to its ultralow quiescent current.

To further improve overall efficiency, the LTC1516 operates as either a doubler or tripler, depending on V_{IN} and V_{OUT} load conditions. The part also has thermal shutdown protection and can survive an indefinite short from V_{OUT} to GND. In shutdown conditions, the load is disconnected from V_{IN} .

The LTC1516 can be substituted for the MAX619 with improved performance. The part is available in 8-pin PDIP and 8-pin SO packages.

LT1307 1-Cell Micropower 675kHz PWM DC/DC Converter

The LT1307 is a micropower, fixed frequency DC/DC converter that operates from an input voltage as low as 1V. The first device to achieve true PWM performance from a 1-cell supply, the LT1307 automatically shifts to power-saving Burst Mode operation at light loads. High efficiency is maintained over a broad 100 μ A to 100mA load range. The device includes a low-battery detector with a 200mV reference, and consumes less than 5 μ A in shutdown mode. No-load quiescent current is 50 μ A, and the internal NPN power switch handles a 400mA current with a voltage drop of just 240mV.

Unlike competing devices, the LT1307 does not require large electrolytic capacitors. Its high frequency (675kHz) switching allows the use of tiny surface mount multilayer ceramic (MLC) capacitors and small surface mount inductors. It works with just 10 μ F of output capacitance and requires only 1 μ F of input bypassing.

The LT1307 is available in the SO-8 package. 

For further information on the above or any of the other devices mentioned in this issue of *Linear Technology*, use the reader service card or call the LTC literature service number: 1-800-4-LINEAR. Ask for the pertinent data sheets and application notes.

Burst Mode, Bits-to-Nits and C-Load are trademarks of Linear Technology Corporation.

, LTC and LT are registered trademarks used only to identify products of Linear Technology Corp. Other product names may be trademarks of the companies that manufacture the products.

Information furnished by Linear Technology Corporation is believed to be accurate and reliable. However, Linear Technology makes no representation that the circuits described herein will not infringe on existing patent rights.

DESIGN TOOLS

Applications on Disk

NOISE DISK

This IBM-PC (or compatible) program allows the user to calculate circuit noise using LTC op amps, determine the best LTC op amp for a low noise application, display the noise data for LTC op amps, calculate resistor noise, and calculate noise using specs for any op amp. Available at no charge.

SPICE MACROMODEL DISK

This IBM-PC (or compatible) high density diskette contains the library of LTC op amp SPICE macromodels. The models can be used with any version of SPICE for general analog circuit simulations. The diskette also contains working circuit examples using the models, and a demonstration copy of PSpice™ by MicroSim. Available at no charge.

Technical Books

1990 Linear Databook • Volume I — This 1440 page collection of data sheets covers op amps, voltage regulators, references, comparators, filters, PWMs, data conversion and interface products (bipolar and CMOS), in both commercial and military grades. The catalog features well over 300 devices. \$10.00

1992 Linear Databook Supplement — This 1248 page supplement to the 1990 Linear Databook is a collection of all products introduced since then. The catalog contains full data sheets for over 140 devices. The 1992 Linear Databook Supplement is a companion to the 1990 Linear Databook, which should not be discarded. \$10.00

1994 Linear Databook • Volume III — This 1826 page supplement to the 1990 Linear Databook and 1992 Linear Databook Supplement is a collection of all products introduced since 1992. A total of 152 product data sheets are included with updated selection guides. The 1994 Linear Databook Volume III is a supplement to the 1990 and 1992 Databooks, which should not be discarded. \$10.00

1995 Linear Databook • Volume IV — This 1152 page supplement to the 1990, 1992 and 1994 Linear Databooks is a collection of all products introduced since 1994. A total of 80 product data sheets are included with updated selection guides. The 1995 Linear Databook Vol IV is a companion to the 1990, 1992 and 1994 Linear Databooks, which should not be discarded. \$10.00

Linear Applications Handbook • Volume I — 928 pages full of application ideas covered in depth by 40 Application Notes and 33 Design Notes. This catalog covers a broad range of "real world" linear circuitry. In addition to detailed, systems-oriented circuits, this handbook contains broad tutorial content together with liberal use of schematics and scope photography. A special feature in this edition includes a 22 page section on SPICE macromodels. \$20.00

1993 Linear Applications Handbook • Volume II — Continues the stream of "real world" linear circuitry initiated by the 1990 Handbook. Similar in scope to the 1990 edition, the new book covers Application Notes 41 through 54 and Design Notes 33 through 69. Additionally, references and articles from non-LTC publications that we have found useful are also included. \$20.00

Interface Product Handbook — This 424 page handbook features LTC's complete line of line driver and receiver products for RS232, RS485, RS423, RS422, V.35 and AppleTalk® applications. Linear's particular expertise in this area involves low power consumption, high numbers of drivers and receivers in one package, mixed RS232 and RS485 devices, 10kV ESD protection of RS232 devices and surface mount packages. Available at no charge.

SwitcherCAD Handbook — This 144 page manual, including disk, guides the user through SwitcherCAD—a powerful PC software tool which aids in the design and optimization of switching regulators. The program can cut days off the design cycle by selecting topologies, calculating operating points and specifying component values and manufacturer's part numbers. \$20.00

1995 Power Solutions Brochure, First Edition — This 64 page collection of circuits contains real-life solutions for common power supply design problems. There are over 45 circuits, including descriptions, graphs and performance specifications. Topics covered include PCMCIA power management, microprocessor power supplies, portable equipment power supplies, micropower DC/DC, step-up and step-down switching regulators, off-line switching regulators, linear regulators and switched capacitor conversion. Available at no charge.

AppleTalk® is a registered trademark of Apple Computer, Inc.

World Headquarters

Linear Technology Corporation
1630 McCarthy Boulevard
Milpitas, CA 95035-7417
Phone: (408) 432-1900
FAX: (408) 434-0507

U.S. Area Sales Offices

CENTRAL REGION

Linear Technology Corporation
Chesapeake Square
229 Mitchell Court, Suite A-25
Addison, IL 60101
Phone: (708) 620-6910
FAX: (708) 620-6977

NORTHEAST REGION

Linear Technology Corporation
3220 Tillman Drive, Suite 120
Bensalem, PA 19020
Phone: (215) 638-9667
FAX: (215) 638-9764

Linear Technology Corporation

266 Lowell St., Suite B-8
Wilmington, MA 01887
Phone: (508) 658-3881
FAX: (508) 658-2701

NORTHWEST REGION

Linear Technology Corporation
782 Sycamore Dr.
Milpitas, CA 95035
Phone: (408) 428-2050
FAX: (408) 432-6331

SOUTHEAST REGION

Linear Technology Corporation
17000 Dallas Parkway
Suite 219
Dallas, TX 75248
Phone: (214) 733-3071
FAX: (214) 380-5138

Linear Technology Corporation

5510 Six Forks Road
Suite 102
Raleigh, NC 27609
Phone: (919) 870-7834
FAX: (919) 870-8831

SOUTHWEST REGION

Linear Technology Corporation
21243 Ventura Blvd.
Suite 227
Woodland Hills, CA 91364
Phone: (818) 703-0835
FAX: (818) 703-0517

Linear Technology Corporation

15375 Barranca Parkway
Suite A-211
Irvine, CA 92718
Phone: (714) 453-4650
FAX: (714) 453-4765

International Sales Offices

FRANCE

Linear Technology S.A.R.L.
Immeuble "Le Quartz"
58 Chemin de la Justice
92290 Chatenay Malabry
France
Phone: 33-1-41079555
FAX: 33-1-46314613

GERMANY

Linear Technolgy GmbH
Oskar-Messter-Str. 24
85737 Ismaning
Germany
Phone: 49-89-962455-0
FAX: 49-89-963147

JAPAN

Linear Technology KK
5F NAO Bldg.
1-14 Shin-Ogawa-cho Shinjuku-ku
Tokyo, 162 Japan
Phone: 81-3-3267-7891
FAX: 81-3-3267-8510

KOREA

Linear Technology Korea Co., Ltd
Namsong Building, #403
Itaewon-Dong 260-199
Yongsan-Ku, Seoul 140-200
Korea
Phone: 82-2-792-1617
FAX: 82-2-792-1619

SINGAPORE

Linear Technology Pte. Ltd.
507 Yishun Industrial Park A
Singapore 2776
Phone: 65-753-2692
FAX: 65-754-4113

TAIWAN

Linear Technology Corporation
Rm. 602, No. 46, Sec. 2
Chung Shan N. Rd.
Taipei, Taiwan, R.O.C.
Phone: 886-2-521-7575
FAX: 886-2-562-2285

UNITED KINGDOM

Linear Technology (UK) Ltd.
The Coliseum, Riverside Way
Camberley, Surrey GU15 3YL
United Kingdom
Phone: 44-1276-677676
FAX: 44-1276-64851

LINEAR TECHNOLOGY CORPORATION

1630 McCarthy Boulevard
Milpitas, CA 95035-7417

(408) 432-1900

For Literature Only: 1-800-4-LINEAR

