

LINEAR TECHNOLOGY

AUGUST 1997

VOLUME VII NUMBER 3

IN THIS ISSUE...

COVER ARTICLE

The LT[®]1533 Heralds a New Class of Low Noise Switching Regulators

..... 1
Jeff Witt

Issue Highlights 2

LTC in the News 2

DESIGN FEATURES

The LTC[®]1067 and LTC1067-50: Universal 4th Order Low Noise, Rail-to-Rail Switched Capacitor Filters 6

Doug La Porte

LTC1422: Simple and Versatile Hot Swap[™] Solution 11

David Soo

LTC1626 Low Voltage Monolithic Step-Down Converter Operates from a Single Li-Ion Cell 15

Tim Skovmand

LTC1340 Varactor Driver Saves Power in Cellular Phones 18

Dave Bell

DESIGN IDEAS

LT1635 1A Shunt Charger 22

Mitchell Lee

Negative-to-Positive Telecommunication Supply 23

Kurk Mathews

Send Camera Power and Video on the Same Coax Cable 24

Frank Cox

MUX the LTC1419 Without Software 25

Kevin R. Hoskins

(More Design Ideas on pages 26–30; complete list on page 22)

DESIGN INFORMATION

Understanding and Applying Voltage References (Part Two) 31

Mitchell Lee

New Device Cameos 37

Design Tools 39

Sales Offices 40

The LT1533 Heralds a New Class of Low Noise Switching Regulators

by Jeff Witt

Every designer approaches switching power supplies with trepidation or dread—these circuits are infamous as generators of noise or electromagnetic interference (EMI). However, switching regulators are indispensable when systems require small size, high efficiency, battery-powered operation or isolated power. Modern analog systems combine these requirements with demands for ever increasing performance; RF communications devices are becoming more sensitive and analog-to-digital converters are pushing analog measurements to greater resolution and bandwidth. Such systems cannot tolerate interference from any source.

Noise is Due to Fast Switches

Ill effects due to ripple voltages and currents at the operating frequency of a switching regulator can usually be eliminated by careful design. Low ESR capacitors, closed inductors, LC filters and proper trace routing to avoid ground loops and IR drops will reduce this noise to acceptable levels.

However, switching regulator EMI problems are most often the result of high frequency noise generated by switching high potentials or currents. In order to maintain high efficiency, these transitions are designed to occur as quickly as possible. These fast edges will couple capacitively or

inductively to nearby circuitry, and can radiate energy to nearby or even remotely placed circuits. The magnitude of such stray coupling and its potential for causing trouble are difficult to predict. Once discovered, eliminating these effects requires a lot of experimenting, numerous layout revisions, expensive shielding, black art and good luck.

Introducing the LT1533 Low Noise Switcher

The LT1533 is a new switching regulator that provides a solution to EMI problems through two flexible approaches. First, the slew rates of both the current through the power switch and the voltage on it are easily programmed with external resistors. Limiting these slew rates will remove the highest harmonics from the switching waveforms. Second, the LT1533, with two 1A power switches, is designed to operate in push-pull circuits. Such circuits, with their low input and output current ripple, are inherently quiet. The result is an integrated switching regulator that provides very quiet output power and very low emissions. Figure 1 gives an example of what can be achieved. The top trace shows the output of a push-pull boost regulator generating 120mA at 12V from an input of 5V. This trace was measured using a 10M Ω

continued on page 3



LT, LTC and LT are registered trademarks of Linear Technology Corporation. Adaptive Power, Burst Mode, C-Load, FilterCAD, Hot Swap, LinearView, Micropower SwitcherCAD and SwitcherCAD are trademarks of Linear Technology Corporation. Other product names may be trademarks of the companies that manufacture the products.

Issue Highlights

Our cover article for this issue introduces the LT1533, a new switching regulator that provides a solution to EMI problems through two flexible approaches. First, the slew rates of both the current through the power switch and the voltage on it are easily programmed with external resistors. Limiting these slew rates removes the highest harmonics from the switching waveforms. Second, the LT1533 is designed to operate in push-pull circuits. Such circuits, with their low input and output current ripple, are inherently quiet. The result is an integrated switching regulator that provides very quiet output power and very low emissions.

Another power control device, the LTC1626 low voltage monolithic stepdown converter, also debuts in this issue. The LTC1626 is a monolithic, low voltage, step-down current mode DC/DC converter with an input supply voltage range of 2.5V to 6V, making it ideal for single-cell Li-Ion or 3- to 4-cell NiCd/NiMH applications. A built-in 0.32Ω (at $V_{IN} = 4.5V$) P-channel switch allows up to 0.6A of output current. The LTC1626 incorporates automatic power saving Burst Mode™ operation to reduce gate-charge losses when the load current drops below the level required for continuous operation. With no load, the converter draws only $160\mu A$; in shutdown it draws a mere $1\mu A$ —making it ideal for current-sensitive applications.

Also introduced in this issue is a specialized power device, the LTC1340 varactor driver. This novel product neatly fills a “crack” that has appeared in the block diagram of portable communications equipment—the need to provide 5V swing to the VCO control input even though the rest of the product operates at 3V. The LTC1340 is a low noise amplifier with an output that can swing to nearly twice the supply voltage. A 4MHz on-chip charge-pump DC/DC converter produces the doubled supply voltage to power the amplifier. The IC, to-

gether with three ceramic capacitors, consumes a mere 0.065 in^2 of PC board area.

On the filter front, we present the LTC1067 and LTC1067-50 universal, 4th order switched capacitor filters designed for rail-to-rail operation. Each part contains two identical, high accuracy, very wide dynamic-range 2nd order filter building blocks. Each building block, together with three to five resistors, provides 2nd order filter transfer functions, including lowpass, bandpass, highpass, notch and allpass. These parts can be used to easily design 4th order or dual 2nd order filters. Both parts are double sampled and can operate on supplies from $\pm 5V$ to 3V.

Also included in this issue is a new Hot Swap™ controller, the LTC1422. Hot Swap controllers allow circuit boards to be safely plugged into a live backplane. Like the LTC1421 Hot Swap controller, introduced in the August 1996 issue of *Linear Technology*, the LTC1422 can handle supply voltages in the 3V–12V range. The difference between these two parts is in the number of supplies that can be independently controlled: the LTC1421 is a 3-channel device, whereas the LTC1422 is a single-channel device.

This issue features an exceptionally large and varied selection of Design Ideas. There's a solar-powered battery charger, 3V to 1.xV, 12V to 5V and $-48V$ to 5V DC/DC converters, a circuit that allows video from and power to a surveillance camera to share the same coax cable, a short-circuit protected isolated high-side switch, some novel applications for the LTC1590 12-bit DAC and a method for MUXing the LTC1419 14-bit ADC without software.

This issue also includes the conclusion of the in-depth examination of voltage reference specifications, begun in the June 1997 issue of *Linear Technology*. We conclude with a half dozen New Device Cameos. 

LTC in the News...

Linear Technology Corporation announced on July 22 that net sales for its fiscal year ended June 29 were \$379,251,000, a nominal increase over net sales of the \$377,771,000 for the previous year. The Company also reported record net income of \$134,371,000 for the year, a nominal increase over last year's \$133,964,000. Earnings per share decreased nominally from \$1.72 in FY97, as the increase in net income was offset by an increase in shares outstanding.

According to Robert Swanson, president and CEO, “our business accelerated nicely in the second half of the year and we concluded the year attaining record bookings, sales and net profit. We are going into the new year with good momentum. We are even on Mars with several of our products on both the Pathfinder spacecraft and the Sojourner robot.”

Net sales for the fourth quarter were \$104,075,000, a 16% increase over the fourth quarter of the previous year. Net income for the quarter was \$37,402,000 or \$0.47 per share, compared with \$31,357,000 or \$0.40 per share, an increase of 19% over the fourth quarter of the previous year. Sequentially, the results for the fourth quarter were up 10% as compared to net sales and net income reported for the third quarter of \$95,033,000 and \$33,980,000 or \$0.43 per share.

Linear Technology is increasing its quarterly dividend from \$0.05 to \$0.06 per share. Payment will be on August 20, 1997 to shareholders of record on August 1, 1997.

These impressive financials are one of the reasons that Linear Technology has again appeared in the “The Business Week Global 1000,” where companies are ranked according to their market value. LTC's market value was ranked at 441, ahead of such firms as Harris, Southwest Airlines and Maxim. LTC has also been ranked in the “Top 200,” a listing of the leading electronic companies worldwide, ranked by electronics sales revenue, in the July issue of *Electronic Business Today*.

Chicago Corporation analyst David Wu in New York said of LTC, “The global markets are improving, orders are up, and the telecom industry, in which Linear participates strongly is up. In the long run, Wu estimates “Linear's sales can grow in the area of 25%.” 

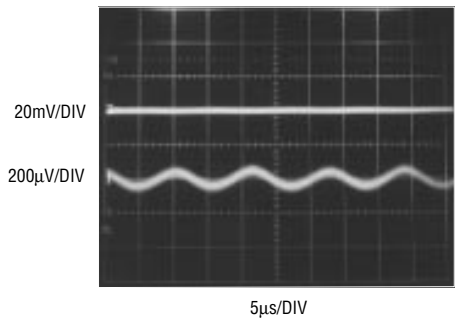

Figure 1. Output ripple of an LT1533 switching regulator producing 120mA at 12V from a 5V input

LT1533, continued from page 1

oscilloscope probe with a six-inch ground lead, demonstrating that there is no significant inductively or capacitively coupled noise. Probing the output of the LT1533 circuit with a 50Ω low noise amplifier reveals the real performance (second trace): peak-to-peak output ripple of the low noise switcher is only 150µV in a 10kHz to 100MHz bandwidth.

A Closer Look at the LT1533

The LT1533 is a fixed frequency current mode PWM switching regulator. Output voltage is regulated by controlling the peak switch current on each cycle of the oscillator, resulting in good transient performance and rapid current limiting. The oscillator (see the block diagram in Figure 2) drives a toggle flip-flop, alternately enabling one of two 0.5Ω NPN power switches, QA and QB. The switch current is monitored by a sense resistor at the emitter of the switch. The output voltage (either positive or negative) is compared with an accurate internal 1.25V reference voltage by an error amplifier whose current output, along with loop compensation components tied to the VC pin, determine the peak switch current required for regulation; a comparator turns off the switch when this current level is reached.

The slew-control circuitry monitors the collector voltages and emitter currents of the power switches and adjusts base drive to control both the voltage and current slew rates. The desired rates are programmed by tying the RVSL and RCSL pins to ground with resistors between 4k and 68k, corresponding to slew rates from ~80V/µs to 5V/µs and 7A/µs to 0.4 A/µs. This allows the circuit designer to directly trade off quiet, low EMI operation with high efficiency: low slew rates result in slowly changing stray fields, which generate less interference, but increase the conduction losses in the switches.

The LT1533 oscillator presents additional opportunities for managing EMI. Its wide frequency range (20kHz to 250kHz) allows the designer to avoid sensitive frequencies. Operating frequency is set with a capacitor

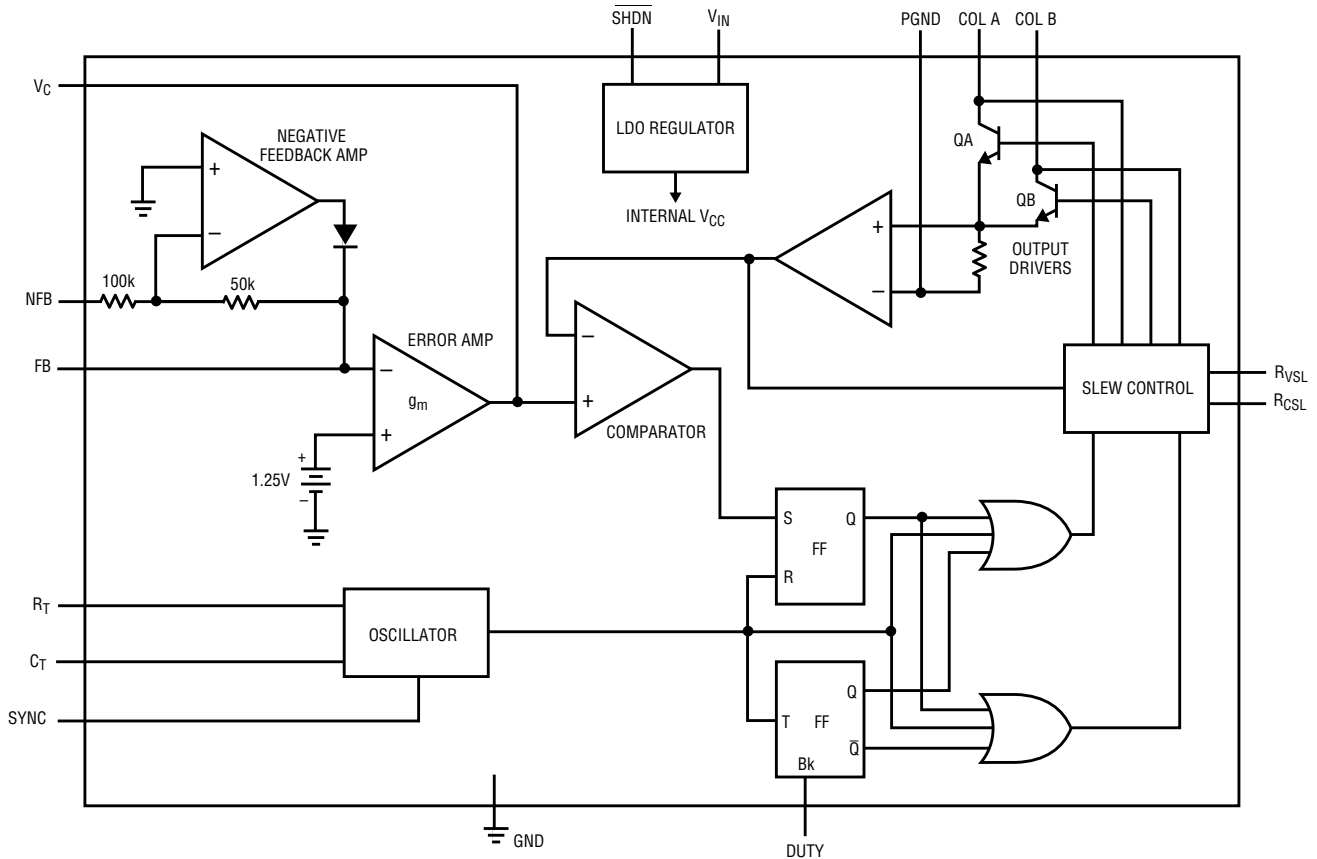

Figure 2. LT1533 block diagram

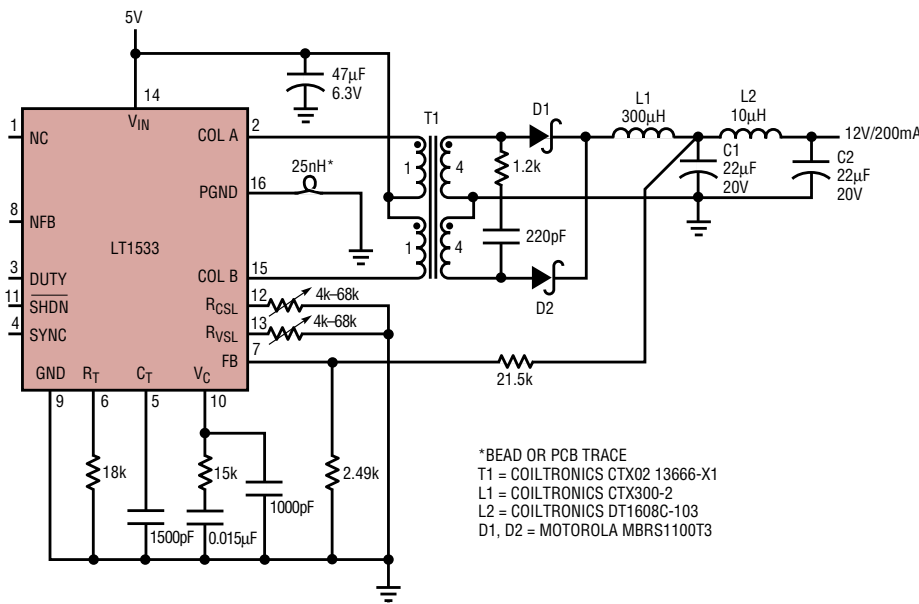

Figure 3. 5V to 12V push-pull PWM converter

on the C_T pin and a resistor of nominally 17k on the R_T pin. The LT1533 can also be synchronized to an external clock, allowing accurate placement of both switching frequency and phase.

Push-Pull PWM Makes a Quiet Boost Converter

The push-pull converter in Figure 3 produces 200mA at 12V from an input of 5V. The oscillator is set to 80kHz (note that the circuit operates at half this frequency) and the LT1533 applies a pulse-width modulated 5V to the primary side of the transformer. The rectified secondary voltage is filtered by L1 to generate 12V on C1. In this circuit, L1 is the primary energy storage device, so the transformer

can be made fairly small. Additional output filtering is provided by L2 and C2.

This topology is inherently quiet. Current through L1 into the primary output capacitor C1 is a continuous triangle wave with little high frequency content, resulting in low conducted output noise. With an appropriate transformer turns ratio, RMS input current is kept low, reducing the potential for conducted noise on the input.

It is advantageous to start with a good topology, but high frequency noise will still get around via stray capacitance and mutual inductance; the best way to deal with this is to eliminate fast edges. Figure 4 shows several waveforms from the circuit as

it delivers 120mA of output current. The upper trace in each photo is the current in switch QA as it turns off. Trace B is the output voltage probed with a 10MΩ scope probe with a six-inch ground lead. The lower trace is the output measured with a low noise amplifier. In the left photo the switch slew rates are programmed to their highest values with 3.9k resistors on the R_{CSL} and R_{VSL} pins. The fast switch transients induce high frequency ripple on the output (the higher level of noise on the middle trace is due to the inductance of the scope probe's ground lead). By lowering the slew rates ($R_{CSL} = 24k$ and $R_{VSL} = 8.2k$) this potentially troublesome output ripple is eliminated, as shown in the right photo. The efficiency penalty is minor; the slower slew rates reduce efficiency from 73% to 70%.

This combination of appropriate circuit topology and controlled slew rates produces the exceptionally clean output shown in Figure 1. This circuit is simply implemented with ordinary PCB construction, and can be placed in close proximity to sensitive circuits without the need for expensive electrostatic or magnetic shielding.

DC Transformer with Civilized Edges

Grounding the Duty pin of the LT1533 disables the feedback loop and runs each switch at 50% duty cycle, allowing the LT1533's use in DC transformer circuits. Such circuits are useful for generating bipolar or isolated supplies; Figure 5 shows an

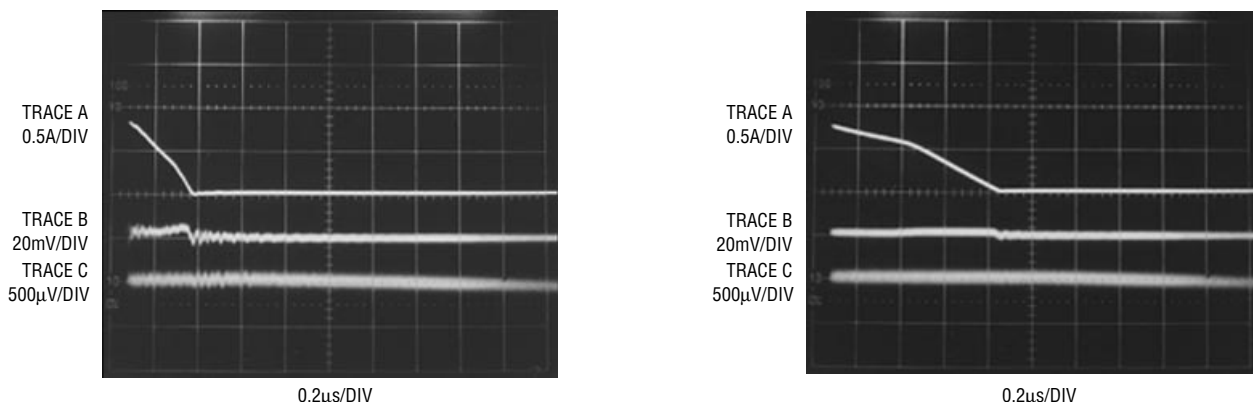

Figure 4. Lowering the slew rates of the power switches (Trace A) eliminates high frequency ripple at the output (Traces B and C).

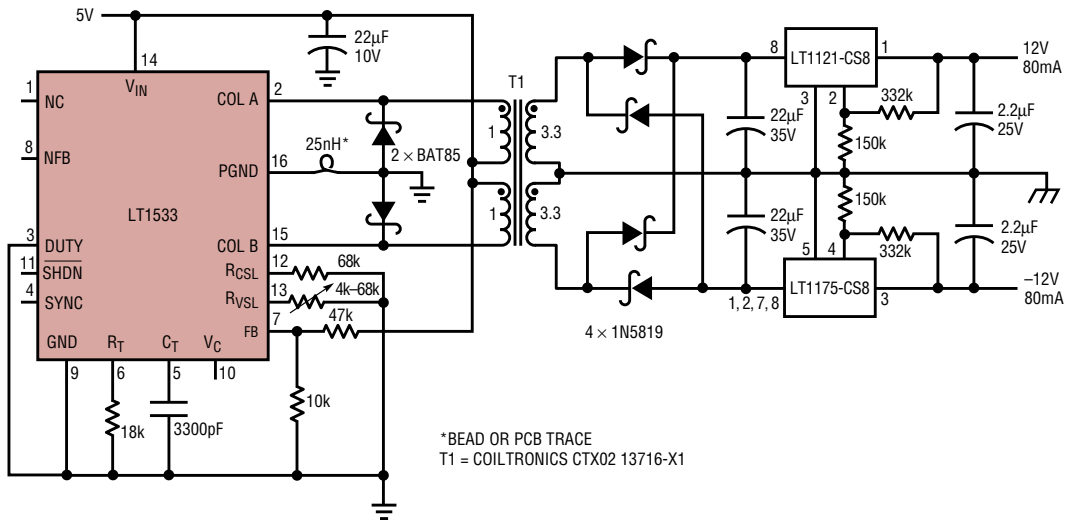

Figure 5. 5V to ±12V DC transformer

example. The LT1533 switches 5V across a 3.3:1 transformer and a diode bridge rectifies the secondary side voltages to produce nominally 16V bipolar outputs that are regulated to ±12V. Short-circuit current limit at the output is provided by the LT1533's switch current limit; the 1A switch limit is transformed to 0.3A on the secondary.

A common problem with isolated-output switchers is that fast edges couple through stray capacitance between the primary and secondary

windings of the transformer to create common mode noise on the outputs. Also, linear regulators are incapable of rejecting high frequency noise at their inputs. Both problems are greatly reduced by limiting the switch slew rates. Shielding between the windings can be eliminated, reducing transformer size and cost. LC filters on the isolated side are unnecessary with the linear regulators rejecting ripple at the operating frequency and the controlled slew rates eliminating high frequency ripple.

3.3V to 5V Boost Converter

Simple switching topologies can also benefit from the LT1533's low noise features. In a boost regulator, for example, the current into the output capacitor is a square wave, which contains the high frequency harmonics generated by a fast power switch. Even when the rectifying diode is off, fast voltage waveforms at the switch couple through the Schottky diode's capacitance. Fast switching can also excite high frequency resonant circuits formed by the diode's capacitance and parasitic inductance due to board traces. All of these effects can be reduced by controlling the slew rate of the switch. Figure 6 shows the LT1533 in a simple boost circuit generating 5.0V from a 3.3V input, a typical requirement when interfacing 3.3V logic systems to 5V high performance ADCs. The collectors of the two power switches are tied together and alternately energize the boost inductor. Figure 7 shows several waveforms at two different slew rate settings with the circuit delivering 200mA of output current. Trace A is the switch voltage, trace B is the current through the output capacitor and trace C is the AC-coupled output voltage in a 100MHz bandwidth. In the left photo, the slew rates are set to their maximum values ($R_{CSL} = R_{VSL} = 3.9k\Omega$). The rapidly switched current combined with the finite series inductance of the output capacitor result in large

continued on page 21

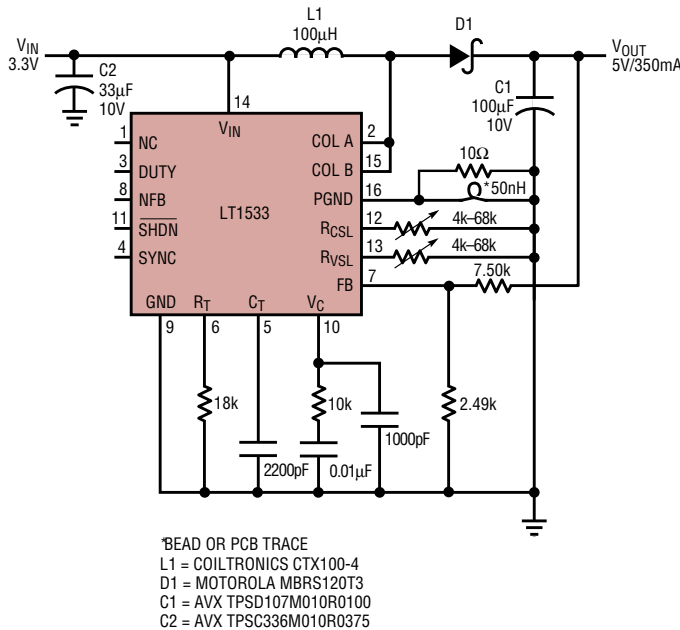

*BEAD OR PCB TRACE
 L1 = COILTRONICS CTX100-4
 D1 = MOTOROLA MBRS120T3
 C1 = AVX TPSD107M010R0100
 C2 = AVX TPSC336M010R0375

Figure 6. 3.3V to 5V boost converter

The LTC1067 and LTC1067-50: Universal 4th Order Low Noise, Rail-to-Rail Switched Capacitor Filters

by Doug La Porte

Introduction

Modern products require ever smaller and more efficient designs. Much of yesterday's desktop equipment has been replaced by small, often battery-operated, portable systems in today's world. Filter products must follow this trend and must address the requirements of today's system designer. These requirements include small package size, operation at reduced power supply voltages, low power consumption and large output voltage swings to accommodate high dynamic-range signals.

The LTC1068 family of universal, 8th order switched capacitor filters were the first products to answer the bell. They are half the size of the previous generation of devices and their performance is superior in every respect. Next, the LTC1069 family of preconfigured, fully integrated, switched capacitor filters raised the bar in performance and ease of use. The LTC1069's performance specifications, coupled with standard SO-8 packaging and zero external components, match the needs of modern systems. Now, a brand new family of parts has been added to the Linear Technology filter portfolio: the LTC1067 and LTC1067-50.

Why Another Building Block?

The LTC1068 family provides an excellent solution for high performance 8th order filters, but many systems do not need an 8th order filter; a 4th order filter will do the job. These systems will either use the LTC1068 with extra unused sections or one of the older MF-10-type parts. The MF-10, in its many versions, was a fine product in its day, but its day has passed. Modern systems must operate on low power supply voltages. The MF-10 parts are only good down to a

5V supply and most systems today use 3.3V supplies. To get acceptable performance and high dynamic range on a 3.3V power supply, the filter must have a low noise input structure and provide a large output swing. If the output only swings to 800mV from the positive supply rail, you are throwing away about 25% of the available dynamic range. For this reason, a rail-to-rail output stage is desired. On the lower supply voltages, the part's DC offset also becomes more significant. The LTC1067 and LTC1067-50 were designed to fill the needs of the 4th order filter market. It is not just another version of the MF-10, but a completely new design. It is made for modern systems; it operates on a 3V power supply, with low DC offset, low input noise, rail-to-rail output swing, low power consumption and small packaging. These new parts also deliver much tighter frequency accuracy than any previous product. This opens the door to reliable, repeatable narrow-band filter designs.

LTC1067 and LTC1067-50 Overview

The LTC1067 and the LTC1067-50 are universal, 4th order switched capacitor filters with rail-to-rail operation. Each part contains two identical, high accuracy, very wide dynamic-range 2nd order filter building blocks. The block diagram for both parts is identical (see Figure 1). Each building block, together with three to five resistors, provides 2nd order filter transfer functions, including lowpass, bandpass, highpass, notch and allpass. These parts can be used to easily design 4th order or dual 2nd order filters.

Linear Technology's new FilterCAD™ for Windows® filter design software fully supports designs with these parts. FilterCAD is a very powerful Windows-based filter design program, available free of charge from Linear Technology. Consult Linear Technology's marketing or applications staff for more information.

Windows is a registered trademark of Microsoft Corp.

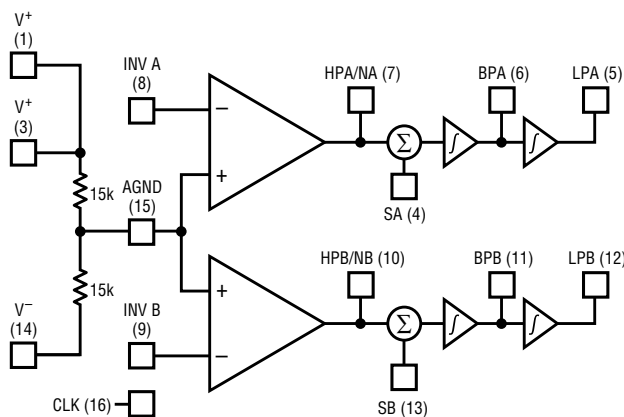

Figure 1. LTC1067/LTC1067-50 block diagram

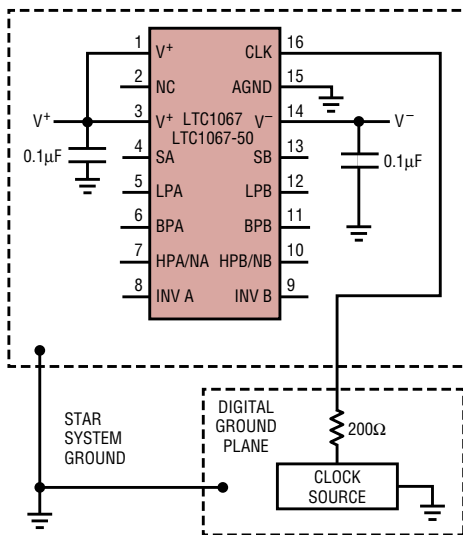

Figure 2a. Dual-supply ground plane connections

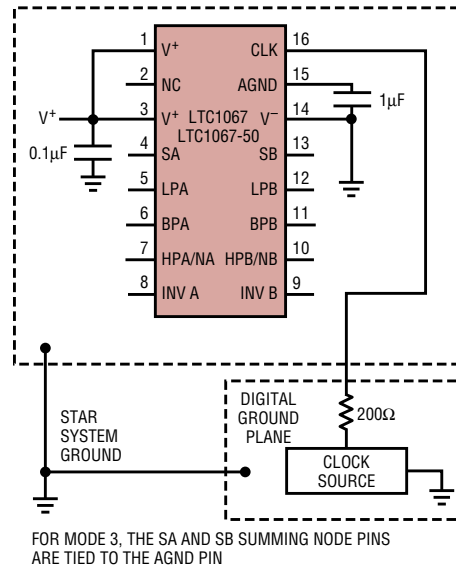

Figure 2b. Single-supply ground plane connections

The center frequency of each 2nd order section is tuned by an external clock. The LTC1067 has a 100:1 clock-to-center frequency ratio. The LTC1067-50's clock-to-center frequency ratio is 50:1. Both of these parts are double sampled. Double sampling has the advantage of placing all aliasing and imaging issues at twice the clock frequency. Ratios other than 100:1 or 50:1 are achieved by using external resistors and choosing the operating mode configuration. For more details on the operating modes, consult the LTC1067/LTC1067-50 data sheet.

The LTC1067 and LTC1067-50 have the following salient features:

- ❑ Rail-to-rail input and output operation
- ❑ Operation from single 3V to ±5V supply
- ❑ 16-pin narrow SSOP or SO-16 packages
- ❑ >80dB dynamic range from a 3.3V supply
- ❑ Tight f_0 accuracy: ±0.2% typical, ±0.55% maximum
- ❑ Low DC offset: ≤ 5mV typical
- ❑ Low noise: < 70µV_{RMS} (4th order Butterworth LPF)

These parts also consume small amounts of supply current. The LTC1067 typically draws 2.0mA from a 3V supply, 2.55mA from a 3V supply, 2.55mA from a 4.75V

supply and 4.35mA from a ±5V supply. The LTC1067-50 typically consumes about one half of the LTC1067's supply current: 1.0mA from a 3V supply, 1.45mA from a 4.75V supply and 2.35mA from a ±5V supply. The LTC1067-50 is a lower power, slightly faster version of the LTC1067. However, the LTC1067 has slightly lower noise, lower DC offset and tighter f_0 tolerance than the LTC1067-50. These parts allow the designer to trade off one set of specifications for the other. The LTC1067 is preferred, by virtue of its higher sampling rate, for notch and highpass filters, due to the broad-band nature of these filters.

Both parts are designed for single- or dual-supply-voltage applications. The parts have an integrated voltage divider network; only a decoupling capacitor is required to set a mid-supply potential for single-supply systems. Figure 2 shows the power supply connections for dual- and single-supply operation.

The LTC1067 and LTC1067-50 are ideally suited for today's systems. The ability to operate on low supply voltages, with low supply current, combined with low noise, low DC offset and rail-to-rail output swing, makes these parts perfect for battery-operated systems that require high dynamic range. The small 16-pin nar-

row SSOP package is also in line with the compact packaging requirements. These parts also feature tight f_0 accuracy, allowing highly repeatable, manufacturable narrow-bandwidth bandpass and notch filters.

The LTC1067 and LTC1067-50 are also mask programmable. This allows the designer to specify the filter's response and have the part delivered as a fully optimized, integrated solution that has been tested to meet the exact system specifications. Mask-programmed parts have all external resistors integrated, have the supply current adjusted for the specific application and come in the small SO-8 package. This results in a minimal-real-estate, zero-external-components design that is optimized and tested to meet the design requirements. For more information on mask-programmed parts, call Linear Technology's marketing department.

When designing filters, especially high Q filters, consult the "Maximum Q vs Center Frequency" curves and the applications information in the LTC1067/LTC1067-50 data sheet. These curves serve as a guide to how fast you can push any design and still maintain a highly repeatable design. Using the FilterCAD design software will automatically alert you to any design that is beyond the limits of the part.

**Let the Games Begin:
Some LTC1067 and
LTC1067-50 Applications**

**High Dynamic-Range
Butterworth Lowpass Filter
with Built-In Track-and-Hold
Challenges Discrete Designs**

Figure 3 shows an LTC1067 configured as a 5kHz Butterworth lowpass filter. This circuit runs on a 3.3V power supply and uses an external logic gate to stop the clock for track-and-hold operation. The transfer function for this circuit, shown in Figure 4, is the classical Butterworth response. This circuit can be used with either the LTC1067 or the LTC1067-50. The broad-band noise for the LTC1067 circuit is $45\mu V_{RMS}$ and the DC offset is typically less than 10mV. For the LTC1067-50, the broad-band noise is $55\mu V_{RMS}$ and the DC offset is typically less than 15mV.

This circuit has tremendous dynamic range, even on low supply voltages. Figure 5 shows a plot of the LTC1067's signal-to-noise plus total harmonic distortion (SINAD) vs input signal level for a 1kHz input at three different power supply voltages. SINAD is limited for small signals by the noise floor of the LTC1067, for medium signals by the part's linearity and for large signals by the output signal swing. The part's low noise input stage and excellent linearity allow the SINAD to exceed 80dB for signals as small as $700mV_{P-P}$, while the rail-to-rail output stage maintains this level for input signals

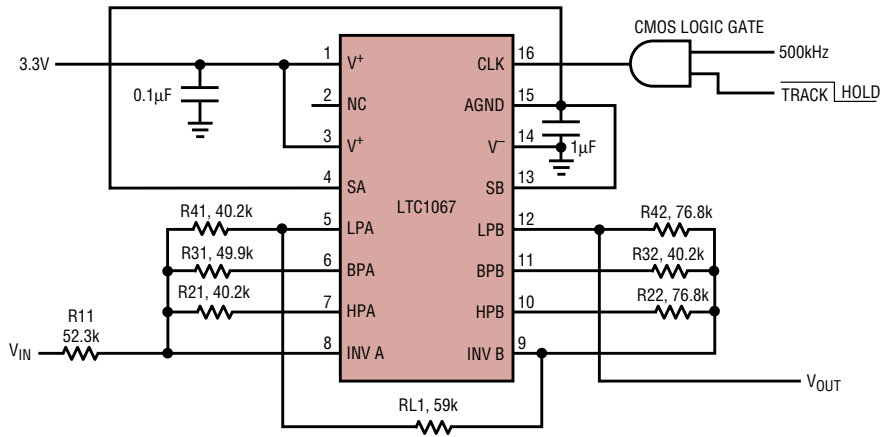

Figure 3. High dynamic-range Butterworth LPF with track-and-hold control

approaching the supply rails. Previous parts could not attain this high dynamic range due to higher input noise levels, poor linearity and limited output-stage signal swing. The low noise and rail-to-rail output swing are especially crucial on the lower 3.3V power supply, where every bit of detectable signal range is precious. Figure 6 shows the same plot for the LTC1067-50 circuit. The dynamic range is not quite equal to that of the LTC1067, but is still very good. Recall that, for the same clock frequency, the LTC1067-50 based filter has double the bandwidth and half the supply current of the LTC1067.

The LTC1067 and LTC1067-50 also perform a track-and-hold function. Stopping the clock holds the output of the filter at its last value. The LTC1067 is the best performing part in this area. The LTC1067's hold step is less than $-100\mu V$ and the droop rate is less than $-50\mu V/ms$ over the full temperature range. These num-

bers compare very favorably with dedicated track-and-hold amplifiers. When the clock is restarted, the filter resumes normal operation within ten clock cycles and the output will then correctly reflect the input as soon as the filter's mathematical response allows.

Elliptic Lowpass Filter

The LTC1067 family is capable of much more challenging filters. Figure 7 shows the schematic for a 25kHz elliptic lowpass filter using the LTC1067-50 operating on a 5V supply. Maximum attenuation one octave from the $-3dB$ corner is the design goal for this filter. Figure 8 shows the frequency response of the filter with the $-3dB$ cutoff at 25kHz and $-48dB$ of attenuation at 50kHz. The broad-band noise of the filter is $85\mu V_{RMS}$ and the DC offset is less than 15mV typically.

Although Figure 7 shows the filter powered by a single 5V supply, 3.3V

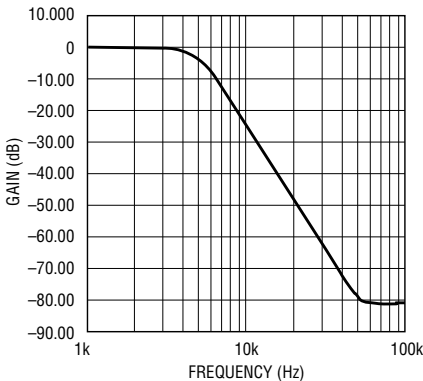

Figure 4. Transfer function of the LTC1067 5kHz Butterworth LPF

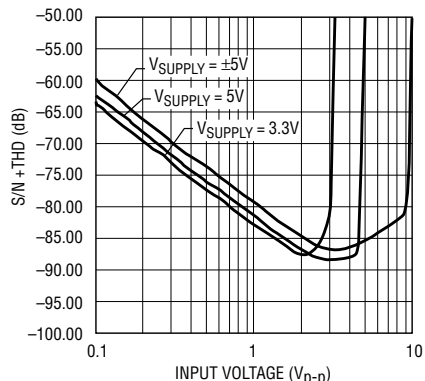

Figure 5. Dynamic range of LTC1067 Butterworth LPF

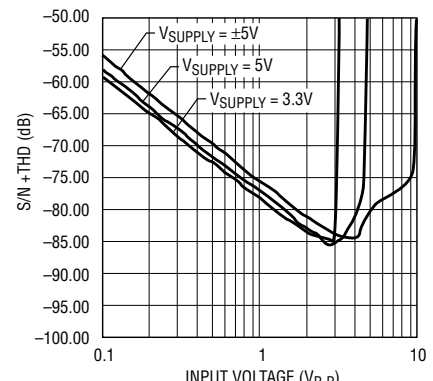

Figure 6. Dynamic range of LTC1067-50 Butterworth LPF

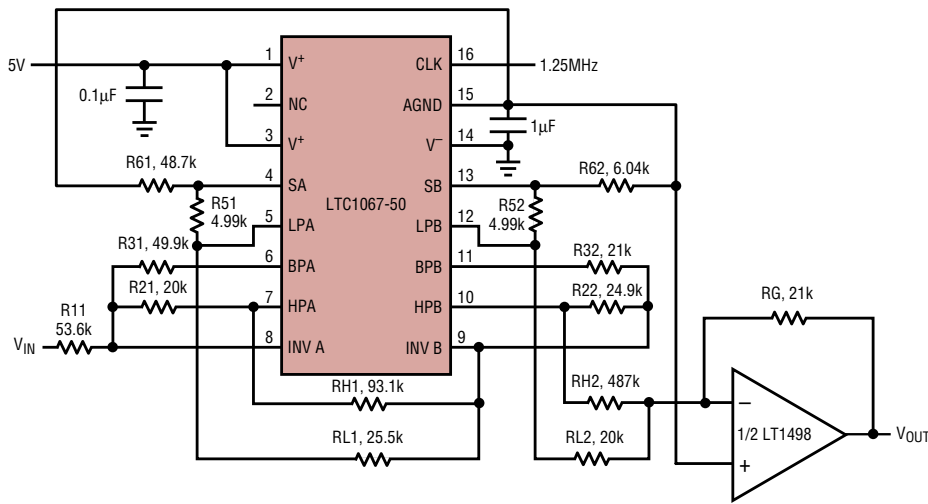

Figure 7. 25kHz elliptic lowpass filter

or $\pm 5V$ supply operation is also supported. The maximum cutoff frequency is 15kHz for the 3.3V supply and 35kHz for the $\pm 5V$ supply. The same design and schematic used with an LTC1067 will achieve a somewhat lower noise, lower DC-offset filter. With the LTC1067, the broad-band noise is $70\mu V_{RMS}$ and the DC offset is typically less than 10mV. The maximum operating frequencies for the LTC1067 are one half of those for the LTC1067-50.

Narrow-Band Bandpass Filter Design Extracts Small Signals Buried in Noise

Narrow-band bandpass filters are difficult to design but are easily achievable with these parts. Most applications for these filters involve extracting a low level signal from a noisy environment. The noise may be the standard broad-band, Gaussian-

type noise or it may consist of multiple interfering signals. For example, the signal may be a low level tone or a narrow-bandwidth modulated signal, in a voice-band system. The presence of the tone must be detected even while the large voice signals are present. A narrow-band bandpass filter will allow the tone to be separated and detected even in this hostile environment. Numerous systems also require a narrow bandpass filter to be swept across a band looking for the tones. Switched capacitor filters allow the filter to be swept by simply changing the clock frequency.

To achieve success in designing narrow-band bandpass filters, you must start with precision components. In an LC or RC design, you would have to start with 0.1% resistors, 1% inductors and 1% capacitors to have any hope of finishing with a successful, repeatable design in production. A competing solution, a digital filter implementation, also requires precision components. The full input signal (signal, noise and out-of-band interference) must be correctly digitized and then processed with a DSP device to finally determine the tone's presence. If an out-of-band interfering signal is 20dB greater than the desired tone, the ADC must have an extra 20dB of dynamic range above the signal's requirement. To pull a small-signal tone from a large signal interferer, you may need a 16-bit ADC to digitize the signal just to get 12-bit resolution of the tone after process-

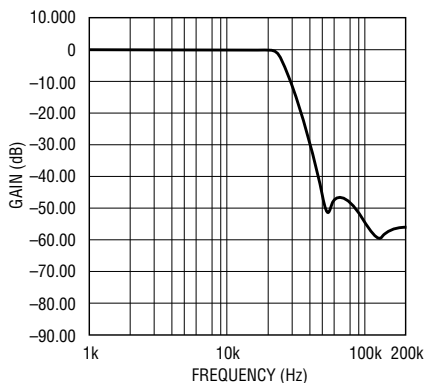

Figure 8. Transfer function of LTC1067-50 25kHz LPF

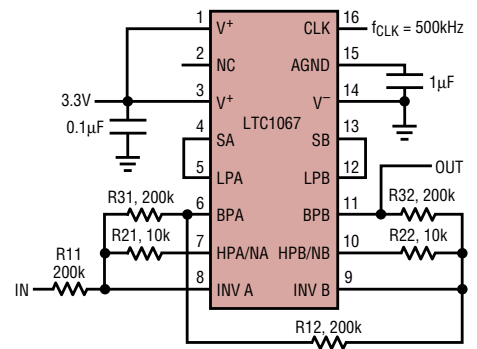

Figure 9. Low noise, low voltage narrow BPF

ing. The added cost, power, board space and development time make this approach unattractive.

A precision switched capacitor filter provides a simple, small, low power, repeatable, inexpensive solution. The older MF-10-type parts do not have the necessary f_0 accuracy to achieve a reliable, repeatable design. Figure 9 shows the schematic of a narrow-band bandpass filter centered at 5kHz. The design uses two identical cascaded sections, each with a Q of 20. Multiply the individual Q of each section by 1.554 to calculate the total Q of a filter with two identical f_0 , identical Q sections. This filter has a total Q of 31. For tunable filter applications, simply lowering the clock frequency lowers the center frequency of the filter. Figure 10 shows the frequency response of this filter. The broad-band noise of this filter is only $90\mu V_{RMS}$. Highly selective bandpass filters are possible due to the LTC1067's excellent f_0 accuracy.

Higher Q , narrower bandwidth filters are achievable with 0.1% resistors

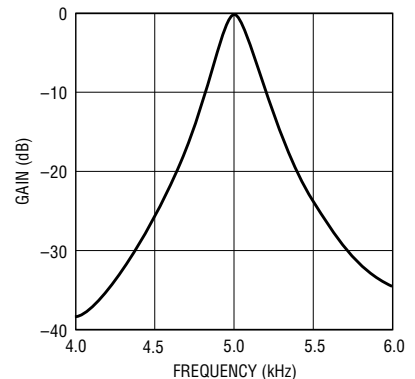

Figure 10. Frequency response of narrow BPF

or matched resistor networks. An LTC1067 mask-programmed part is ideal for these ultranarrow filters. The well matched, on-chip resistors, coupled with specified test conditions, yield a fully functioning filter module, in an SO-8 package, without any of the hassles or cost of procuring precision resistors or resistor networks.

Narrow-Band Notch Filter Design Reaches 80dB Notch Depth

Narrow-band notch filters are especially challenging designs. The requirement for most notch filters is to remove a particular tone and not affect any of the remaining signal bandwidth. This requires an infinitesimally narrow filter that can only be approximated by a reasonably narrow bandwidth. These types of filters, like the narrow-band bandpass discussed above, require precision f_0 accuracy. Figure 11 shows the schematic of this type of filter. This filter is a 1.02kHz notch filter that is often used in telecommunication test systems.

One of the challenges of designing a switched capacitor notch filter involves the broad-band nature of a notch filter. The broad-band noise can be aliased down into the band of interest. Optimal high performance notch filters should employ some form of noise-band limiting. To accomplish the noise-band limiting, the design in Figure 11 places capacitors in parallel with the R2 resistors of each 2nd order section. This forms a pole, set at $f_p = 1/(2 \cdot \pi \cdot R2 \cdot C2)$, that will limit the bandwidth. This pole frequency must be low enough to have a band-limiting effect but must not be so low as to affect the notch filter's response.

The pole should be greater than thirty times the notch frequency and less than seventy-five times the notch frequency for the best results. Figure 12 shows the frequency response of the filter. Note that the notch depth is greater than -80dB. Without the use of the C21 and C22, the notch depth is only about -35dB.

Conclusion

Modern systems' requirements are different from those of the past. The LTC1067 and LTC1067-50 are brand new filter products optimized for today's systems. They are small, highly accurate, low power, rail-to-rail, low noise building blocks that have tremendous versatility. 

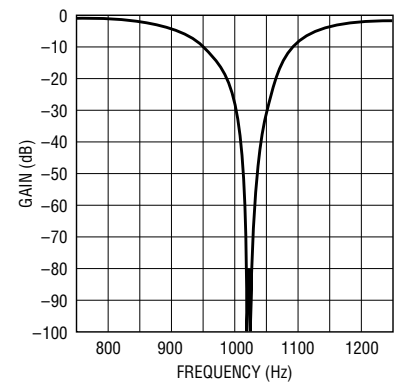
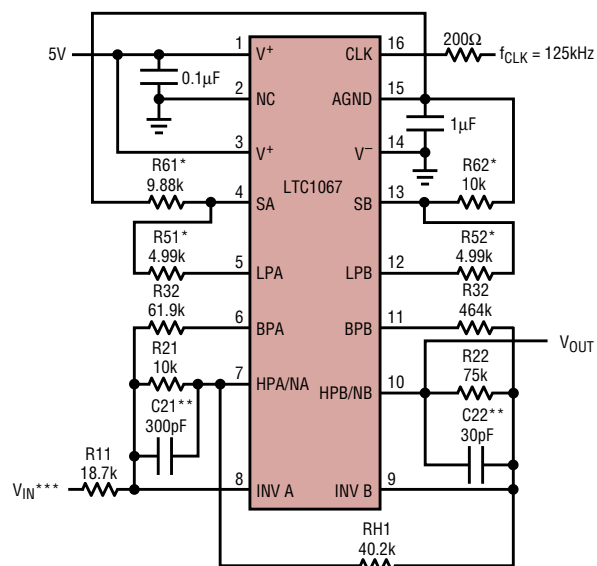

Figure 12. Measured frequency response of Figure 11's narrow-band notch filter



- * R51, R61, R52, R62 ARE 0.1% TOLERANCE RESISTORS
- ** C21 AND C22 IMPROVE THE NOTCH DEPTH WHERE $(30)(f_{NOTCH}) < \frac{1}{2\pi(R2X)(C2X)} < (75)(f_{NOTCH})$ WITHOUT C21 AND C22 THE NOTCH DEPTH IS LIMITED TO -35dB
- *** $V_{IN} \leq 1.25V_{P-P}$

Figure 11. Narrow-band notch filter



LTC1422: Simple and Versatile Hot Swap Solution

by David Soo

Introduction

When a circuit board is plugged into a live backplane, the supply bypass capacitors can draw large transient currents from the backplane power bus as they charge. These inrush currents can destroy board traces or, at the least, disrupt the supply with a large negative transient. There is a need for a protection circuit to power up the board in a controlled manner and provide a low series-resistance connection during normal operation.

The LTC1422 allows a board to be safely inserted into and removed from a live backplane. The rate at which the supply ramps up at the board is programmable. In addition to hot swap protection, it has a voltage monitor and reset output that can be used to supervise the board's circuitry. The device also has overcurrent protection, which disconnects the board during a short circuit. Most impor-

tantly, the LTC1422 combines these features in a compact 8-pin package that simplifies the design of any hot-swapped system.

Typical Application

Like the LTC1421 Hot Swap controller, introduced in the August, 1996 issue of *Linear Technology* the LTC1422 can handle supply voltages in the 3V–12V range. The difference between these two parts is in the number of supplies that can be independently controlled: the LTC1421 is a 3-channel device, whereas the LTC1422 is a single-channel device.

Figure 1 shows a typical application using the LTC1422. In order to protect the board and capacitors, a series-pass transistor, Q1, is placed between the connector and the capacitors. The voltage at the gate of the pass transistor is raised at a con-

trolled rate. Because Q1 is an N-channel transistor, the supply on the board follows the gate ramp minus a threshold voltage. The capacitor-charging current is limited to the capacitor value times the ramp rate of the pass-transistor gate ($I = C \times dv/dt$).

Due to special enhancements to the LTC1422, the supply pin can withstand any supply ramp-up rate. Following the connection of power to the chip, there is a time delay before the GATE pin voltage starts to increase. This allows time for the connector to seat after numerous bounces. This time delay is programmed with the capacitor C2 on the TIMER pin. The ON pin is normally pulled high to allow the part to automatically turn on the pass transistor at power-up. If the ON pin is brought low, the GATE pin will be held at ground.

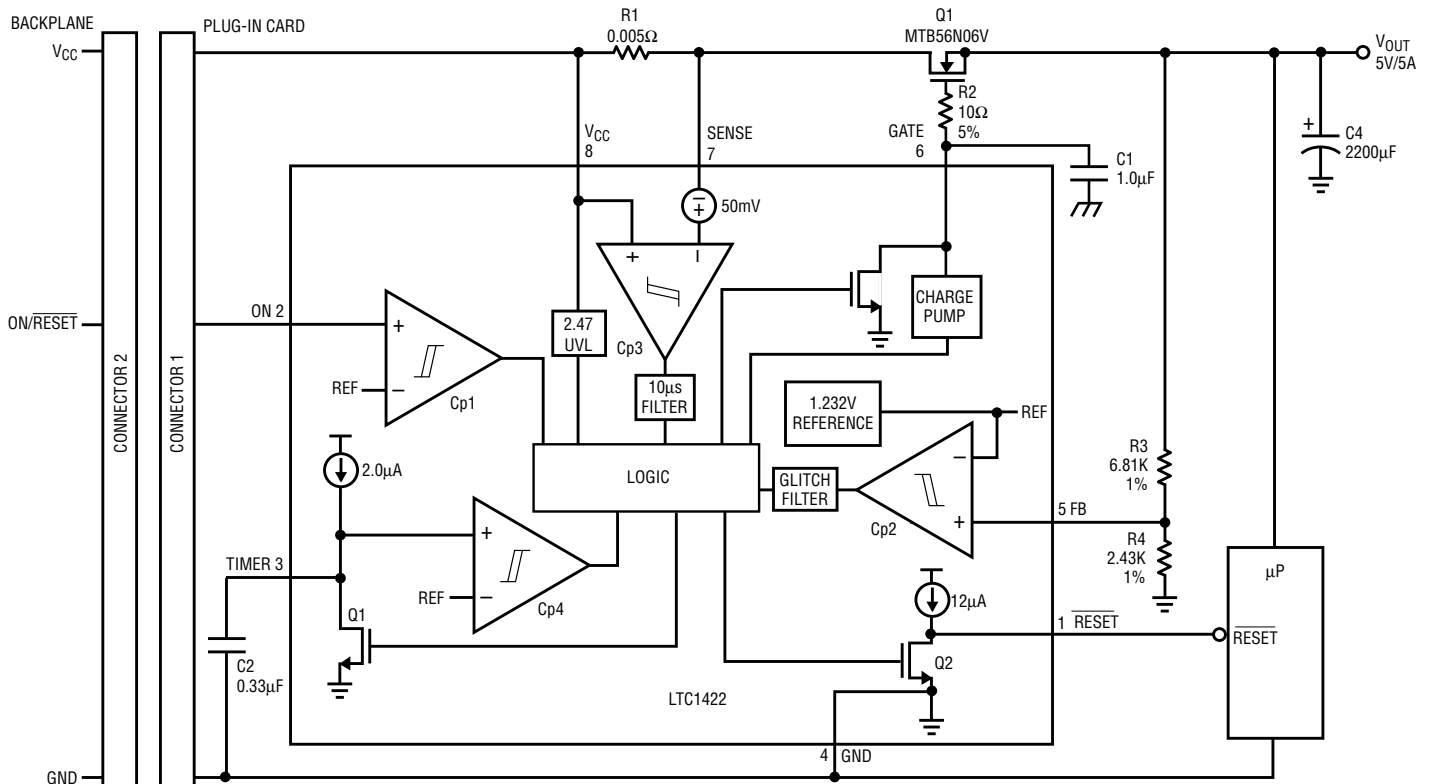

Figure 1. LTC1422 typical application

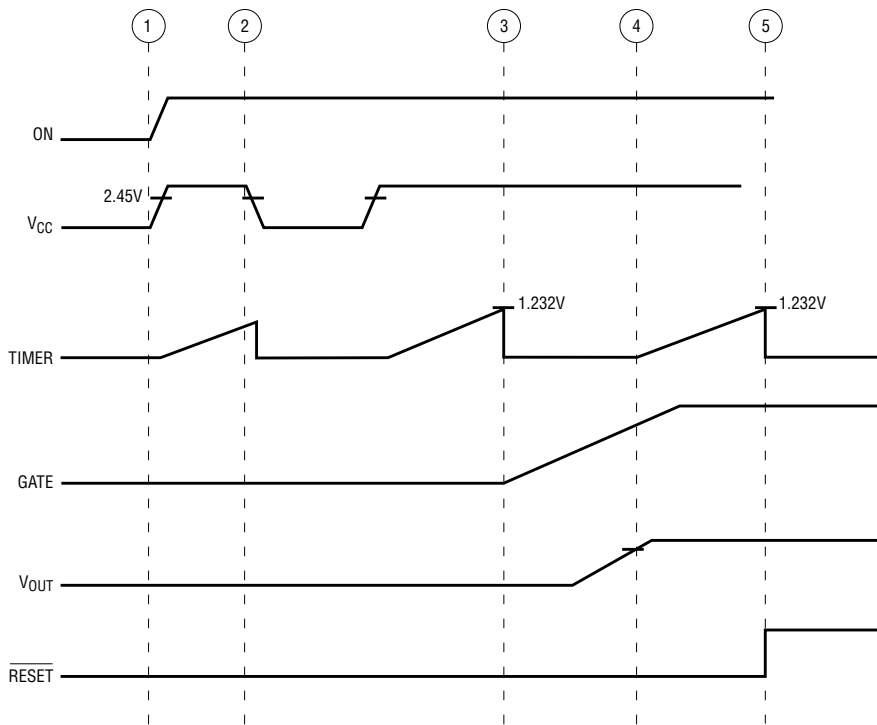

Figure 2. Typical insertion timing

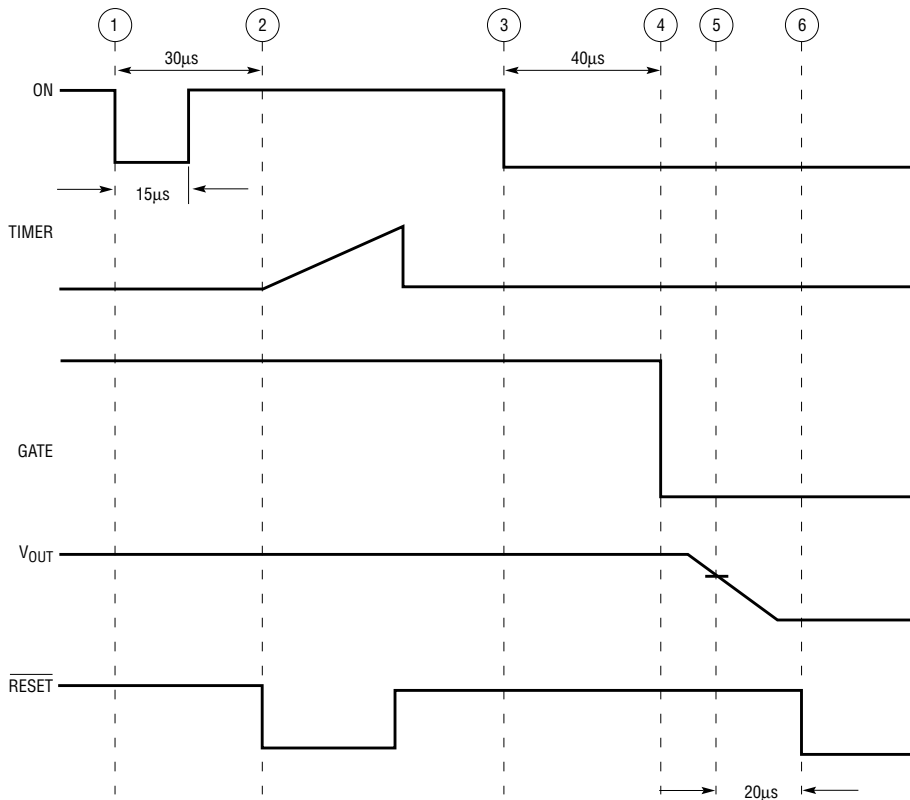

Figure 4. Soft-reset timing

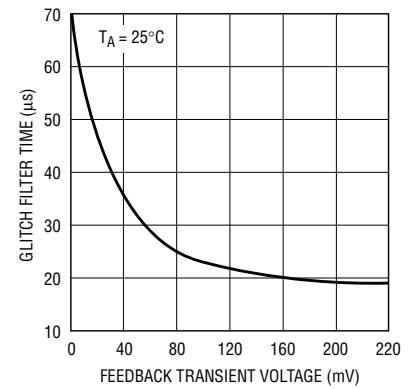

Figure 3. Glitch filter time vs feedback transient voltage

The timing for the board during board connection is shown in Figure 2. When the connector makes initial contact at time point 1, the ON pin is pulled high. If V_{CC} is greater than the 2.45V undervoltage lockout threshold, the TIMER pin starts charging C2 with a $2\mu\text{A}$ current source. At time point 2, the supply opens. V_{CC} now drops below the undervoltage threshold, signaling the LTC1422 to discharge the TIMER pin and wait for supply connection. Once the connector is seated, the TIMER pin completes a full timing cycle by charging to the 1.232V threshold and the voltage at the GATE pin begins to rise (time point 3). The rate at which the voltage at the gate of the pass transistor, Q1, increases is controlled by sourcing a $10\mu\text{A}$ current source into C1. On-chip charge pumps provide gate drive of at least twice V_{CC} to Q1.

Voltage Monitor

The LTC1422 uses a 1.232V reference, a precision voltage comparator and an external resistive divider to monitor the output supply voltage. When the voltage at the FB pin rises above its reset threshold voltage (1.232V), comparator Cp2's output goes high and a timing cycle starts (Figure 2, time point 4). After a complete timing cycle, RESET is pulled high (time point 5). The $12\mu\text{A}$ pull-up current source to V_{CC} on RESET has a series diode so the pin can be pulled above V_{CC} by an external pull-up resistor without forcing current back into the supply.

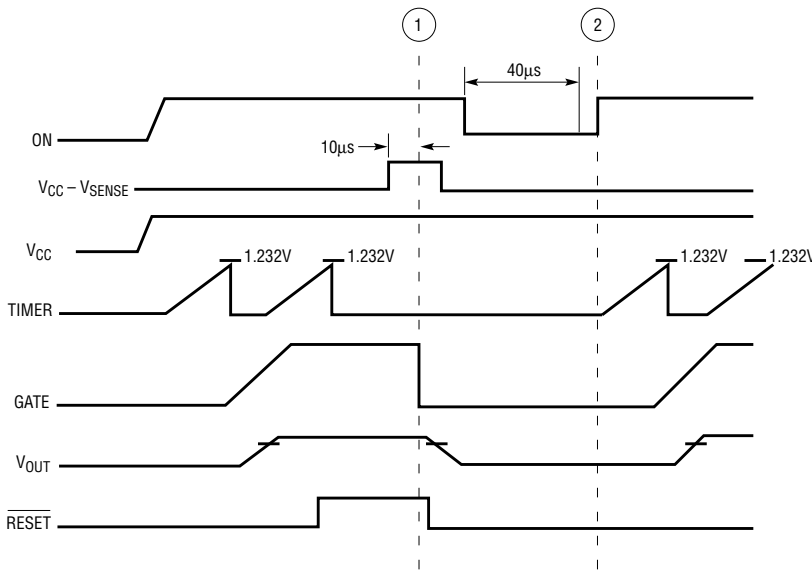

Figure 5. Electronic circuit-breaker timing

pin goes low and stays low for one timing cycle.

If the ON pin is held low for longer than 40µs, the GATE will turn off and the RESET pin will eventually go low (time points 4, 5 and 6).

Hot Swapping Two Supplies

With two external pass transistors, the LTC1422 can switch two supplies. In some cases, it is necessary to bring the dominant supply up first during power-up and ramp it down last during the power-down phase. The circuit in Figure 6 shows how to program two different delays for the pass transistors. The 5V supply is powered up first. R1 and C3 are used to set the rise and fall delays on the 5V supply. Next, the 3.3V supply ramps up with a 20ms delay set by R6 and C2. On the falling edge, the 3.3V supply ramps down first because R6 is bypassed by the diode, D1.

Electronic Circuit Breaker

The LTC1422 features an electronic circuit-breaker function that protects against short circuits or excessive currents from the supply. By placing a sense resistor between the supply input and SENSE pin, the circuit

Glitch Filter

The LTC1422 has a glitch filter to prevent RESET from generating a system reset when there are transients on the FB pin. The filter is 20µs for large transients (greater than 150mV) and up to 80µs for small transients. The relationship between glitch-filter time and the feedback transient voltage is shown in Figure 3.

Soft Reset

In some cases, a system reset without a power-down is desirable. The ON pin can signal the RESET pin to go low without turning off the power (a soft reset). This is accomplished by holding the ON pin low for only 15µs or less (Figure 4, time point 1). At about 30µs from the falling edge of the ON pin (time point 2) the RESET

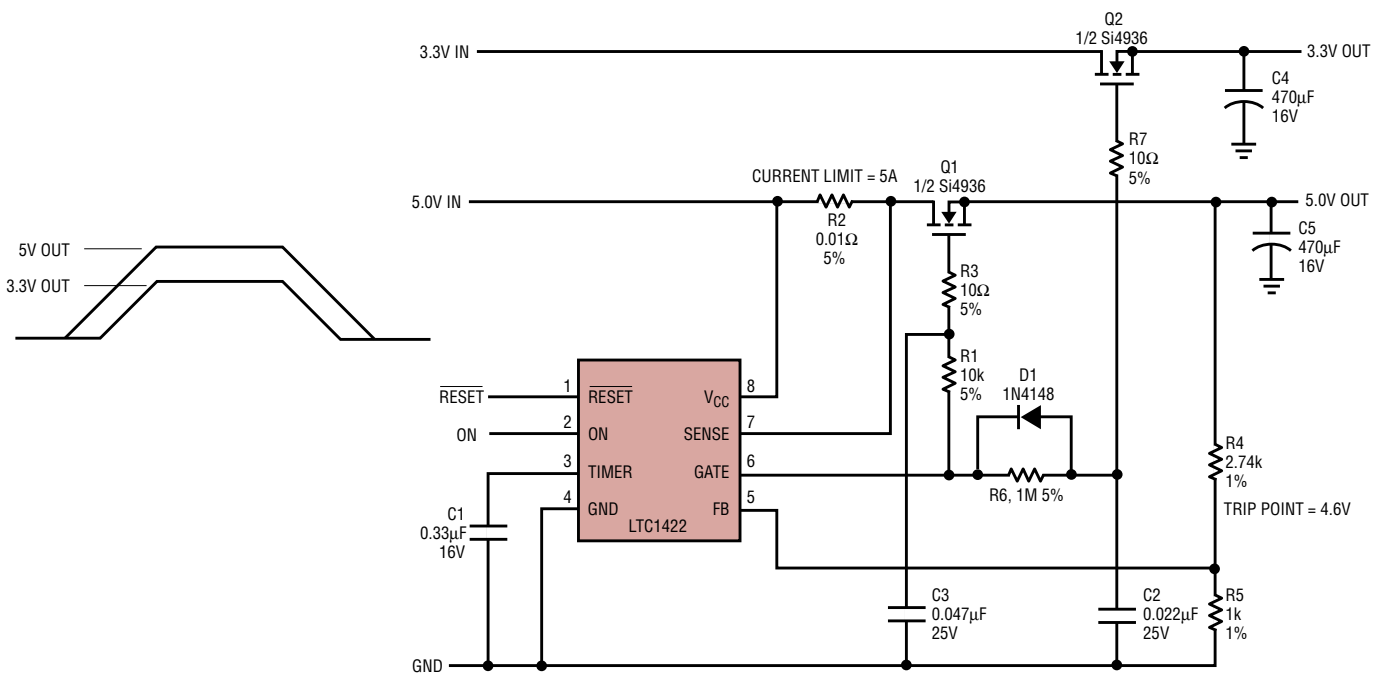

Figure 6. Hot swapping 5V and 3.3V

breaker will be tripped whenever the voltage across the sense resistor is greater than 50mV for more than 10μs. When the circuit breaker trips, the GATE pin is immediately pulled to ground and the external N-channel MOSFET is quickly turned off (Figure 5, time point 1). When the ON pin is cycled off for longer than 40μs and then cycled on (time point 2), the circuit breaker is reset and another turn-on cycle is started. If the circuit breaker feature is not required, the SENSE pin should be shorted to V_{CC}.

Hot Swapping a 48V DC/DC Module with an Active-Low On/Off Control Signal

Using a 5.1V Zener and a resistor, the LTC1422 can switch supplies much greater than its 12V V_{CC} pin rating. As shown in Figure 7, the pass transistor, Q1, is connected as a common source driver rather than as the source

follower used in previous applications. This allows the ground of the LTC1422 to connect to the negative terminal of the 48V input. The clamp circuit consisting of R5 and D1 provides power to the LTC1422.

The ON pin threshold is set at 1.232V by the reference and comparator Cp1 (Figure 1). This allows the resistive divider of R1 and R2 in Figure 7 to monitor the input supply. When the supply is greater than 37V a timing cycle is generated and the pass transistor Q1 is turned on.

Because the pass transistor is in a common-source configuration, care must be taken to limit the inrush current into capacitor C3. One way to do this is to precharge C3 using resistor R4. As the input rises, current flows through R4 and charges capacitor C3. Once the input supply crosses 37V, there is a timing cycle followed by the ramp-up of the GATE pin. By

this time, capacitor C3 is sufficiently charged, thereby limiting the inrush current. Another method for limiting the inrush current is to slow down the ramp-up rate of the GATE pin.

The reset comparator is used to monitor the gate voltage. 290ms after the voltage at the GATE pin exceeds 5.8V, the RESET pin will source 12μA into Q2. The high voltage transistor Q2 is used to translate the RESET signal to the module On/Off input.

Conclusion

Designing hot insertion systems requires a significant effort by an experienced analog designer. One way to reduce the design effort is to use a Hot Swap building block, such as the LTC1422, which offers a charge-pump gate driver, a millisecond timer and other specialized features. With the LTC1422, designers can easily create safe and reliable hot-swapped systems. 

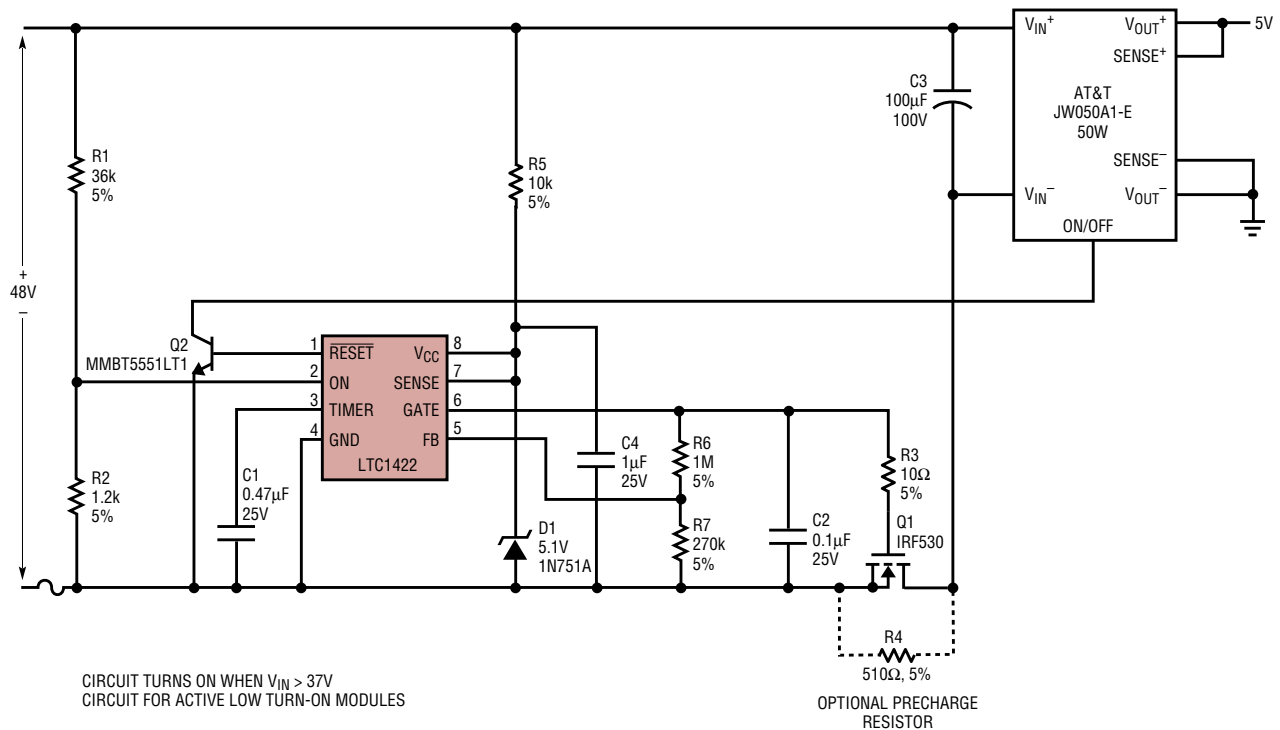

Figure 7. Hot swapping an AT&T 48V module

LTC1626 Low Voltage Monolithic Step-Down Converter Operates from a Single Li-Ion Cell

by Tim Skovmand

Introduction

The LTC1626 is a monolithic, low voltage, step-down current mode DC/DC converter with an input supply voltage range of 2.5V to 6V, making it ideal for single-cell Li-Ion or 3- to 4-cell NiCd/NiMH applications. A built-in 0.32Ω P-channel switch ($V_{IN} = 4.5V$) allows up to 0.6A of output current. The maximum peak inductor current is externally programmable to minimize component size in lower current applications.

The LTC1626 incorporates automatic power saving Burst Mode operation to reduce gate-charge losses when the load current drops below the level required for continuous operation. With no load, the converter draws only $160\mu A$; in shutdown it draws a mere $1\mu A$ —making it ideal for current-sensitive applications.

Single-Cell Li-Ion Operation

As shown in Figure 1, a fully charged single-cell Li-Ion battery begins the discharge cycle at either 4.1V or 4.2V (depending upon the manufacturer's charge voltage specifications). During the bulk of the discharge time, the cell produces between 3.5V and 4.0V. Finally, toward the end of discharge, the cell voltage drops fairly quickly

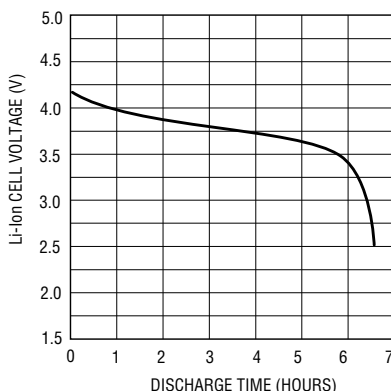

Figure 1. Typical single-cell Li-Ion discharge curve

below 3V. It is recommended that the discharge be terminated somewhere between 2.2V and 2.8V (again, depending upon the manufacturer's specifications).

The LTC1626 is specifically designed to accommodate a single-cell Li-Ion discharge curve. For example, using the circuit shown in Figure 2, it is possible to produce a stable 2.5V/0.25A regulated output voltage with as little as a 2.7V from the battery—thus obtaining the maximum possible run time.

100% Duty Cycle in Dropout Mode

As the Li-Ion cell discharges, the LTC1626 smoothly shifts from a high efficiency switch-mode DC/DC regulator to a low dropout (100% duty cycle) linear regulator. In this mode, the voltage drop between the battery input and the regulator output is determined by the load current and the series resistance of the internal P-channel power MOSFET, the current sense resistor and the inductor resistance. When the battery voltage rises

again, the LTC1626 smoothly shifts back to a high efficiency DC/DC converter.

High Efficiency Operation

Using the circuit shown in Figure 3, efficiencies of greater than 90% are maintained from 20mA to 250mA of load current with a 3.5V input supply voltage, as shown in Figure 4.

Current Mode Architecture

The LTC1626 is a current mode DC/DC converter with Burst Mode operation. This results in a power supply that has very high efficiency over a wide load-current range, fast transient response and a very low dropout characteristic.

An external, small valued sense resistor, R_{SENSE} , provides current feedback, which allows the LTC1626 to continuously control the inductor current. When the load is heavy, the LTC1626 is in continuous operation. During the switch on-time, a built-in current comparator monitors the voltage between the $SENSE^+$ and $SENSE^-$ pins connected across the external

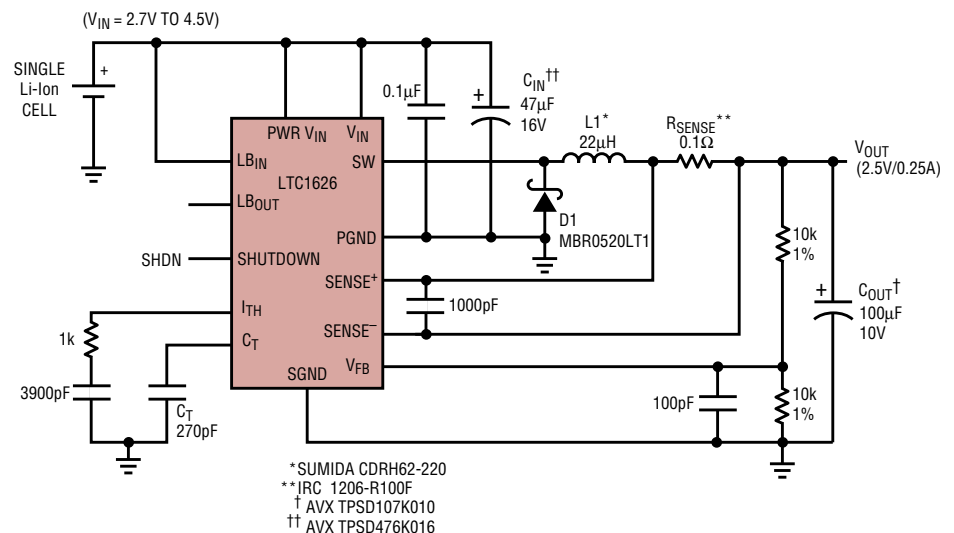

Figure 2. Single-cell Li-Ion battery to 2.5V converter

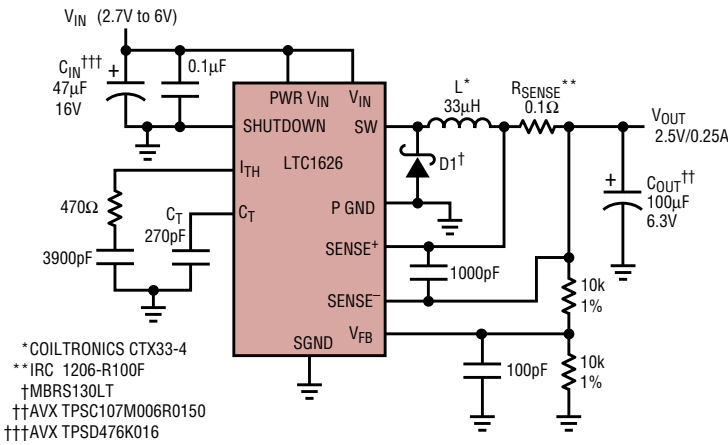

Figure 3. High efficiency 2.5V step-down converter

sense resistor in series with the inductor. When the voltage across the resistor reaches the comparator's threshold value, the internal P-channel MOSFET is switched off. By using a current mode architecture, the inductor current is predictable and well controlled under all operating conditions, making the selection of the inductor much easier.

Current mode control also gives the LTC1626 excellent start-up and short-circuit recovery characteristics. For example, when the output is shorted to ground, the off-time is extended to prevent inductor current run away. When the short is removed, the output capacitor begins to charge and the off-time gradually decreases. The output returns smoothly to regulation without overshooting.

Operating Frequency

The nominal off-time of the LTC1626 is set by an external timing capacitor connected between the CT pin and ground. The operating frequency is then determined by the off-time and the difference between VIN and VOUT.

Figure 5 is a graph of normalized operating frequency versus power supply voltage for the 2.5V regulator shown in Figure 3. Note that the frequency is relatively constant when the supply voltage is between 3.6V and 6V, but drops as the supply voltage approaches the 2.5V regulated output voltage.

The LTC1626 is capable of operating at frequencies up to 700kHz, but the highest efficiency is achieved

between 200kHz and 400kHz. As the frequency increases, losses due to the gate charge of the P-channel power MOSFET increase. In space-sensitive applications, high frequency operation allows the use of smaller components at the cost of a few efficiency points.

Low Voltage, Low RDS(ON) Switch

The integrated P-channel switch in the LTC1626 is designed to provide extremely low resistance at low supply voltages. Figure 6 is a graph of switch resistance vs supply voltage.

Note that the RDS(ON) is typically 0.32Ω at 4.5V and only rises to approximately 0.40Ω at 3.0V. This low switch resistance ensures high efficiency switching as well as low dropout DC characteristics at low supply voltages.

Low-Battery Detection

A built-in low-battery detector senses the input voltage through an external resistive divider. The divided voltage connects to the (-) input of a voltage comparator (LBIN) and is compared to the internal 1.25V reference voltage.

The LBOUT pin is an N-channel open drain that goes low when the battery voltage drops below the threshold voltage. In shutdown, the comparator is disabled and LBOUT is in the high impedance state. Figure 7 is a schematic diagram detailing the low-battery comparator connection and operation.

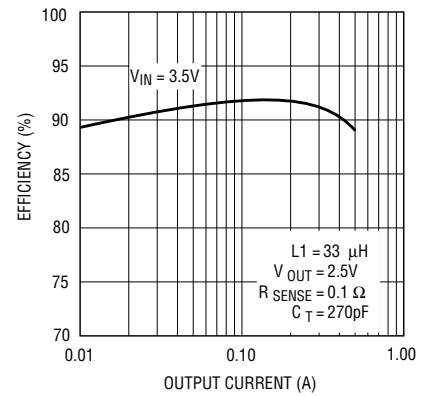

Figure 4. Efficiency vs output load current

Typical Applications

3- or 4-Cell NiCd/NiMH DC/DC Converter

Figure 8 is a schematic diagram that shows the LTC1626 being powered from a 3- or 4-cell NiCd or NiMH battery pack. (This circuit is also suitable for operation from three or four alkaline cells.) All the components

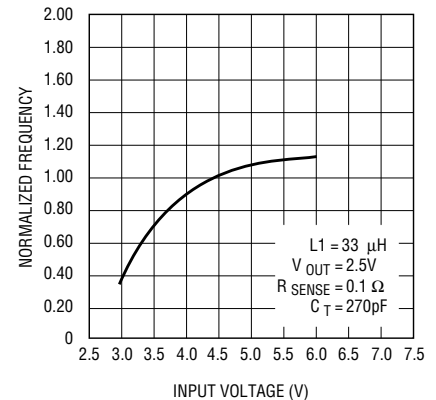

Figure 5. Normalized operating frequency vs supply voltage

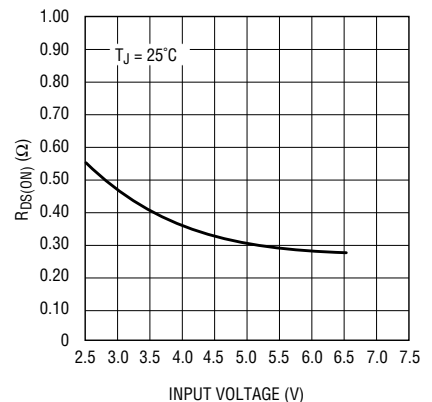

Figure 6. P-channel switch resistance vs input voltage

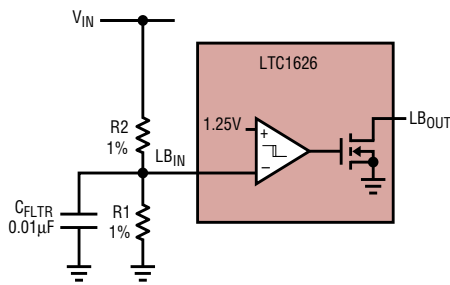

Figure 7. Low-battery detector

shown in this schematic are surface mount and have been selected to minimize the board space and height. The

output voltage is set at 2.5V, but is easily programmed to 3.3V for 4-cell applications. Simply modify the two output ladder resistors, R1 and R2, from 10k each to 15k and 9.09k, respectively, as shown in Figure 8.

Single Li-Ion 3.3V Buck/Boost Converter

The circuit shown in Figure 9 produces 3.3V from an input voltage ranging from 2.5V to 4.5V. The two windings of a common inductor core are used to implement this circuit. Note that the current sense resistor is

connected to ground. The table in Figure 9 shows the output current capability as a function of battery voltage.

Conclusion

The LTC1626 is specifically designed to operate from a single-cell Li-Ion battery. With its low dropout, high efficiency and micropower operating modes, it is ideal for battery operated products and efficiency-sensitive devices such as cellular phones and handheld industrial and medical instruments. 

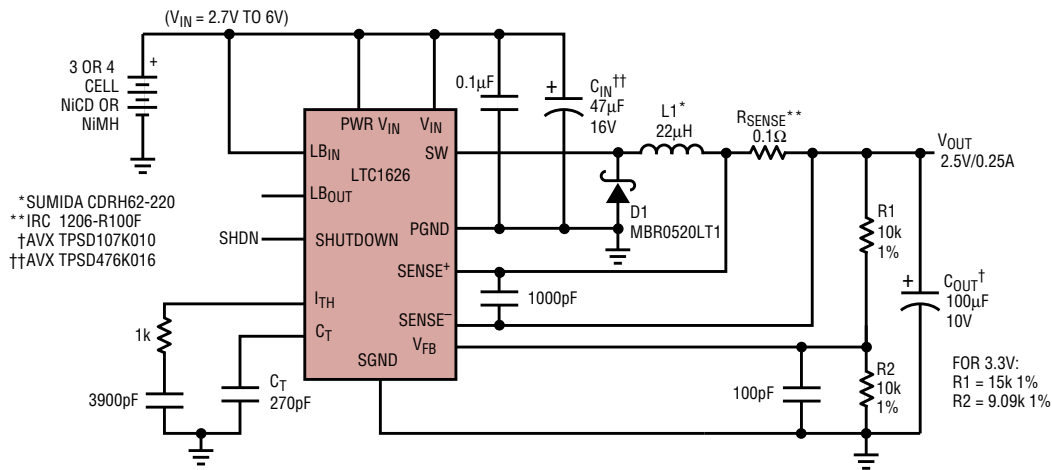

Figure 8. 3- or 4-cell NiCd/NiMH to 2.5V converter

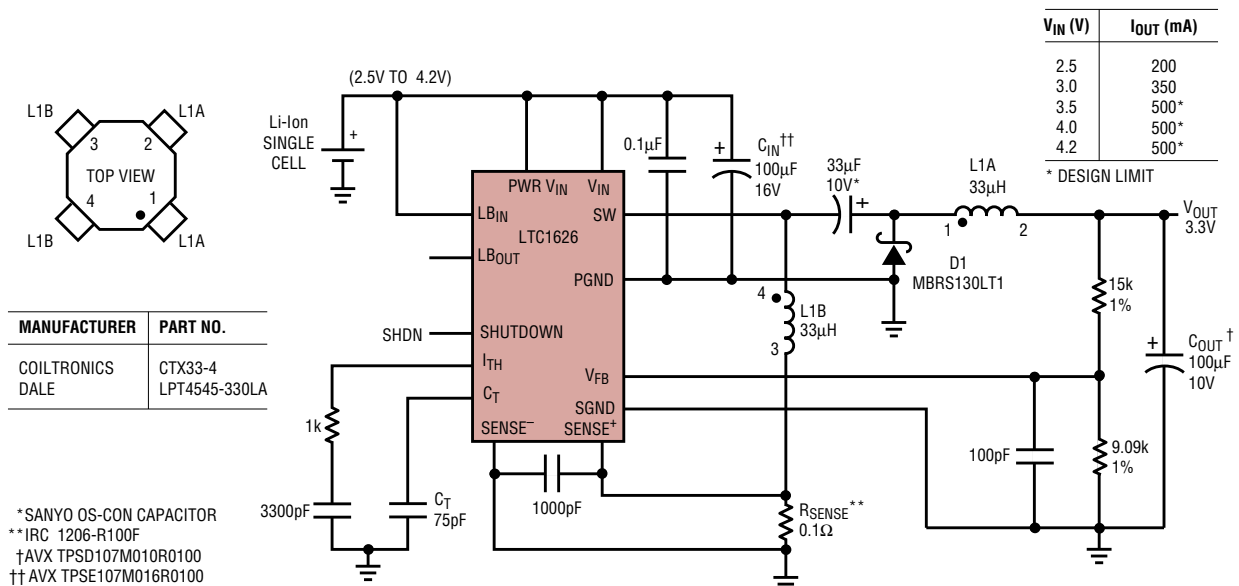

Figure 9. Single-cell Li-Ion to 3.3V buck/boost converter

LTC1340 Varactor Driver Saves Power in Cellular Phones

by Dave Bell

Introduction

Designers of wireless communications equipment are constantly striving to increase the operating time from a battery charge. For example, just a few years ago thirty to forty hours standby time was considered state-of-the-art for a Global System for Mobile Communication (GSM) cellular telephone. Today GSM phones that operate for more than one hundred hours in standby are available. One of the obvious tactics for achiev-

the frequency synthesizer may still be powered from a low noise 5V power supply. This penalizes the product with high power consumption and greater complexity.

Many component manufacturers now offer frequency synthesizer ICs and voltage controlled oscillators (VCOs) that are specified for operation down to 3V, but these still don't represent a total solution. The problem lies with the tuning characteristics of the varactor diode inside the VCO; even though the VCO itself may be operable from a 3V supply, the control voltage input (the cathode of a varactor diode within the VCO's resonant LC tank) usually requires a swing greater than 0V to 3V to span the necessary frequency range. This is especially true when considering the extra tuning range needed to account for production VCO tolerances. What is really needed is a simple method for boosting the control voltage applied to the VCO's varactor diode—and that's precisely what the LTC1340 varactor driver is designed to do.

The LTC1340 is a low noise amplifier with an output that can swing to nearly twice the supply voltage. A 4MHz on-chip charge-pump DC/DC

converter produces the doubled supply voltage to power the amplifier. Size is extremely important in modern cellular telephones, so the LTC1340 is packaged in the diminutive MSOP package. The IC, together with three ceramic capacitors, consumes a mere 0.065 in² of PC board area.

Frequency Synthesizer Basics

Figure 1 depicts a basic phase locked loop (PLL) frequency synthesizer block diagram. The output of the voltage controlled oscillator (VCO) is fed to a phase detector via a programmable frequency divider. The phase detector compares the phase of this divided signal with a reference oscillator. During the period between rising edges of the two signals, one of two current sources is enabled at the output of the phase detector; a current is sourced if the VCO phase is lagging, and a current is sunk if the VCO phase is leading. These current pulses occur once per cycle at the reference oscillator frequency and are integrated on the loop compensation capacitor. The net effect is that the control voltage applied to the VCO increases if

Even in phones that operate almost exclusively from 3V supplies, the frequency synthesizer may still be powered from a low noise 5V power supply. This penalizes the product with high power consumption and greater complexity.

ing such long standby time is reduction of the operating voltage, since reduced operating voltage usually produces a substantial reduction in operating power. Whereas most cellular phones used to operate from 5V supplies, newer models generally operate most circuitry in the range of 3V to conserve power.

Good things in life usually have their trade-offs, and so does reduced operating voltage. Most functions inside a cellular phone can now be obtained with operation specified down to 3V. However, a few circuits still require higher operating voltages. The transmit power amplifier generally requires higher operating voltages to deliver the necessary output power—reducing the operating voltage here doesn't reduce the total power needed. Another area that still causes problems is the frequency synthesizer. Even in phones that operate almost exclusively from 3V supplies,

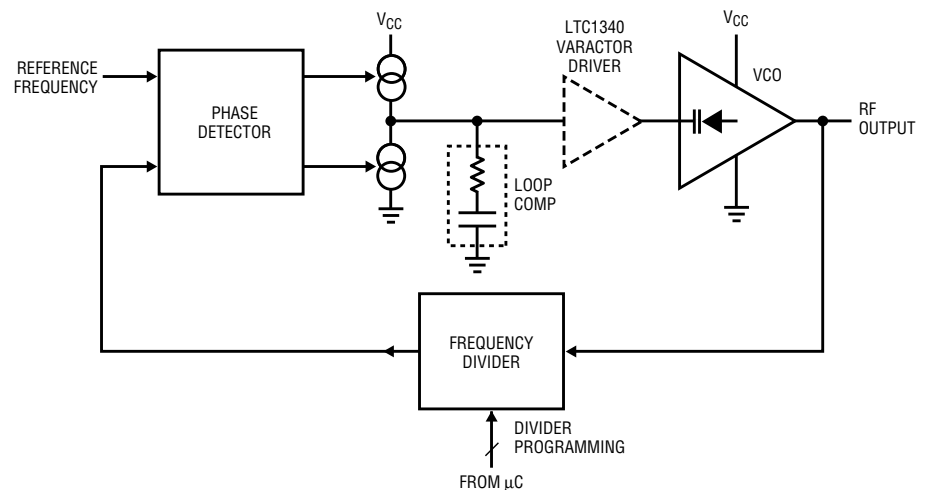

Figure 1. Frequency-synthesizer block diagram

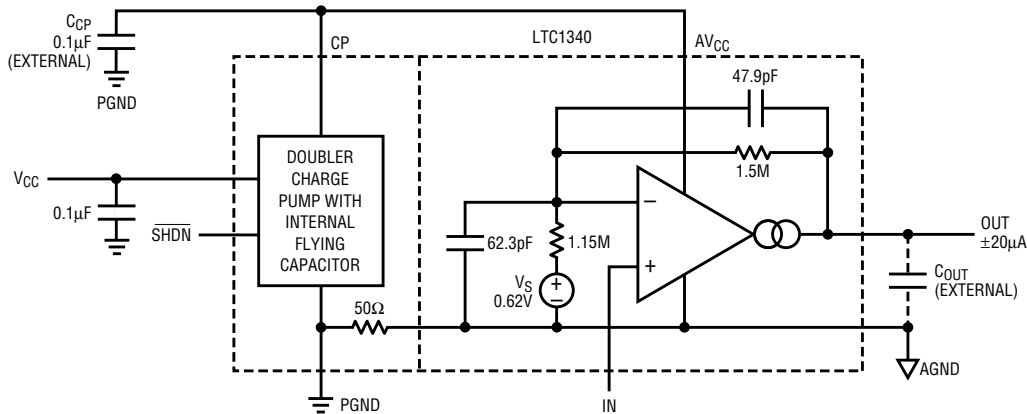

Figure 2. LTC1340 block diagram

the phase is lagging and decreases if the phase is leading until the phase error approaches zero.

Loop compensation components are selected to optimize settling time for the PLL, while keeping “reference spurs” at acceptable levels (reference spurs are unwanted sidebands in the VCO output spectrum at harmonics of the reference frequency). The VCO feedback divider ratio is controlled by a microcontroller to program the desired output frequency to multiples of the reference oscillator frequency.

As mentioned earlier, the phase detector output comprises two current sources. Operating the phase detector output voltage too close to either ground or the positive supply rail causes one of the two current sources to saturate. Usually about 400mV headroom is needed for the current sources to perform within specifications. This means that the VCO control-voltage range is reduced even further because of the headroom required at the phase detector output, with this penalty increasing as a percentage of the total range as supply voltage is reduced. For example, with a 3V power supply the allowable control voltage is approximately 0.4V to 2.6V. The LTC1340 varactor driver is designed to be inserted between the phase detector and the VCO in order to provide a much larger voltage swing at the VCO while keeping the phase detector current sources in the linear region.

LTC1340 Circuit Description

The LTC1340 is conceptually simple—it is a low noise amplifier combined with a charge-pump voltage doubler on the same IC (refer to Figure 2). This is possible because the intended load, a varactor diode, is reverse biased and thus requires practically zero DC current. All that is needed is sufficient output current to slew the varactor diode’s junction capacitance in parallel with the amplifier’s own output filter capacitor. The amplifier is capable of delivering approximately $\pm 20\mu\text{A}$ from its output, so the slew rate isn’t anything to brag about, but it’s sufficiently fast for GSM cellular telephones that must be able to “frequency hop” in approximately 500 μs .

A 2MHz on-chip oscillator drives a biphasic charge-pump DC/DC converter, resulting in charge pulses being delivered at a 4MHz rate. This high frequency operation has two benefits: it allows the use of small on-chip charge-pump capacitors, and it makes the resultant output ripple easy to filter. The entire amplifier operates from the AV_{CC} pin, which is generally tied directly to the charge-pump output (CP). Although the amplifier output stage obviously needs this boosted supply, the amplifier input stage also benefits. Because of the boosted supply on the input stage, the amplifier input is rail-to-rail and operates properly with a phase detector signal anywhere between the input rails.

Noise is the Nemesis

Low noise is without a doubt the most critical parameter of the varactor driver. Noise at the amplifier output results in unwanted frequency modulation of the VCO, which appears as sidebands in the output spectrum. Most RF communications systems have stringent limits on “out-of-band” energy, so this noise must be kept to very low levels. Output noise for the LTC1340 is typically only $15\mu\text{V}_{\text{RMS}}$ ($25\mu\text{V}_{\text{RMS}}$ maximum) over the 1kHz to 100kHz bandwidth. This keeps the out-of-band energy about 15dB below the GSM cellular phone specification limits with a typical VCO.

Output noise comes primarily from three sources. The charge-pump DC/DC converter obviously produces some 4MHz ripple on the CP pin. This can be reduced by a filter network between the CP and AV_{CC} pins, but this measure is generally unnecessary because of the low ripple present at the charge-pump output, and the amplifier’s excellent high frequency power supply rejection ratio (PSRR). A transconductance amplifier was intentionally chosen because it has a high impedance current source output. This high impedance, coupled with an output filter capacitor, results in excellent PSRR even at 4MHz. In fact, the 4MHz charge-pump ripple has been reduced to the point where it is undetectable in output spectrum plots in an actual frequency synthesizer system. The ground side of the filter capacitor may be placed directly

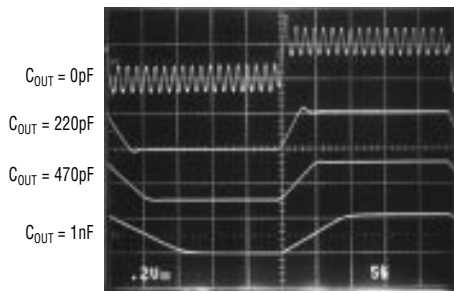

Figure 3. LTC1340 small-signal response

adjacent to the VCO's ground, alleviating additional noise that might result from high frequency ground differential between the LTC1340 and the VCO.

The amplifier's input stage also contributes to output noise, but this effect has been minimized by keeping the input stage quiescent current as high as possible without exceeding the desired power budget. The size of the input transistors was also optimized to put the 1/f noise corner frequency at approximately 10kHz—right where the PLL loop response typically begins to correct for phase noise. The high impedance feedback divider also produces thermal noise, and this, surprisingly, has the largest effect on output noise. The resistor values must be kept large to minimize DC loading on the amplifier output, but large on-chip capacitors across the resistors are used to keep noise in check. Above 2kHz the feedback impedance is dominated by the capacitors, minimizing the noise contribution from the high value resistors.

Other Design Considerations

Although MOSFET transistors have a much higher 1/f corner frequency than bipolar transistors, they were chosen for the input stage to keep bias current to a minimum. Input bias current is guaranteed to be 1nA maximum (25°C) in order to minimize reference spurs that can result from input bias current. Because the phase detector output impedance is high when both current sources are disabled, even small amounts of bias current can result in voltage changes on the small loop compensation

capacitor between phase detector samples. These voltage changes look like a low amplitude sawtooth waveform and result in unwanted frequency modulation of the VCO at the reference frequency.

The transconductance amplifier architecture results in some additional benefits. The current-source output topology of a transconductance amplifier naturally provides nearly rail-to-rail output swing, and this is essential for maximizing the varactor drive range. Because the output capacitor establishes the dominant pole for the amplifier's feedback loop, the amplifier's bandwidth and slew rate can be tailored by proper selection of this capacitor. A 1nF output capacitor results in a bandwidth of approximately 125kHz. The minimum recommended output capacitor for stability is 220pF, resulting in a bandwidth of approximately 560kHz. Both bandwidth and slew rate are inversely proportional to output capacitance over a wide range of values. The relationships among output capacitance, bandwidth and slew rate can be seen in Figure 3.

Voltage source V_S in Figure 2 produces intentional offset in the LTC1340's transfer function. Referring now to Figure 4, it can be seen that this offset allows the amplifier output to go within 100mV of ground even though its noninverting input is at approximately 400mV. Because the amplifier has a gain of approximately 2.3, the amplifier output can be saturated high while the input is still approximately 400mV below the input supply (assuming a 3V nominal supply voltage). This transfer function provides for rail-to-rail output swing while keeping the phase detector current sources in the linear region.

The whole point of reduced operating voltages in portable communication equipment is power reduction, so any additional current consumed by the LTC1340 itself must be kept small. Only 380µA total current is drawn from a 3V input supply, allowing significant reductions in overall system power consumption. This power efficiency, coupled with

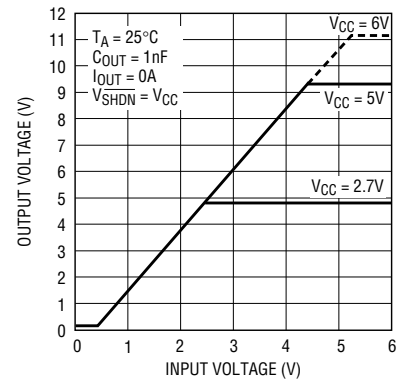

Figure 4. LTC1340 DC transfer curve

the small PCB area needed, make the LTC1340 very attractive for modern cellular telephones.

GSM Frequency Synthesizer Evaluation Circuit

An evaluation circuit has been developed to demonstrate the performance of the LTC1340 varactor driver in an actual frequency synthesizer application. This circuit replicates a complete transmit frequency synthesizer for a GSM cellular telephone. Configuration switches allow programming the output to 890MHz, 902.4MHz or 915MHz (bottom, middle and top of the GSM band).

The GSM cellular protocol supports "frequency hopping"—changing the frequency rapidly between time slots. In the case of a GSM cellular telephone, one synthesizer is often used for both transmit and receive on a time-division multiplexed basis. This requires that the frequency synthesizer be able to change to a new frequency and stabilize in just over 500µs. The evaluation circuit may

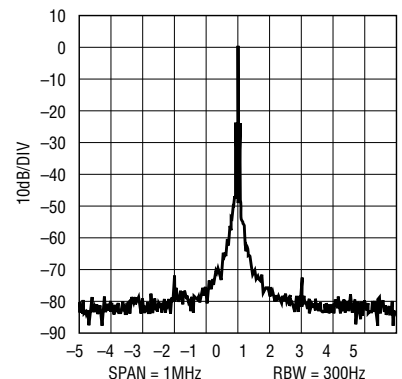



Figure 5. Spectrum plot of frequency synthesizer's RF output

Summary

The LTC1340 varactor driver is the smallest, most power-efficient solution for delivering increased varactor drive to low voltage VCOs. This novel product neatly fills a “crack” that has appeared in the block diagram of portable communications equipment—the need to provide 5V swing to the VCO control input even though the rest of the product operates at 3V. 

also be programmed to hop between the bottom and top frequencies once every millisecond, demonstrating its ability to hop and settle within 500 μ s.

Figure 5 shows a spectrum analyzer plot measured at the synthesizer's RF output. The excellent noise performance of the LTC1340 can be seen from the roughly -75 dBc measure-

ment ± 100 kHz off carrier (each horizontal division is 100kHz). Small “reference spurs” can be observed at ± 200 kHz off carrier due to the synthesizer's 200kHz reference frequency. The amplitude of these reference spurs can be traded against PLL settling time by optimization of the loop filter components.



Authors can be contacted
at (408) 432-1900

LT1533, continued from page 5

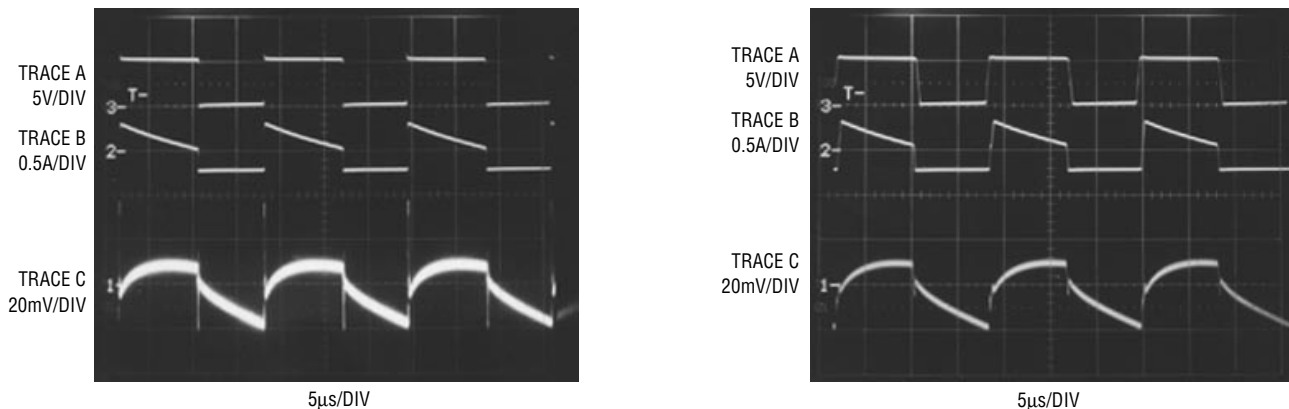

Figure 7. Limiting switch slew rates (Traces A and B) lowers the high frequency content of the boost regulator's output ripple (Trace C).

voltage spikes on the output. The right photo shows the same waveforms with the slew rates lowered ($R_{CSL} = R_{VSL} = 22k$), eliminating the troublesome transients. The penalty is a drop in efficiency from 85% to 80%.

Conclusion: a Switcher for Sensitive Systems

With two 1A power switches, the ability to control positive or negative outputs, and a wide input operating

range (2.7 to 30V), the LT1533 is a highly flexible switching regulator. Thermal shutdown, in addition to switch-current limit, provides circuit protection. The LT1533 is packaged in the narrow 16-lead SO, and is available in commercial and industrial grades.

The LT1533 allows the circuit designer to add a switching regulator to sensitive analog systems without fear of introducing uncontrollable noise and interference. The program-

mable operating frequency and switch slew rates allow final tuning to occur in the circuit, when the system is running and interference problems may first become apparent. In addition to providing a way to deal with unforeseen problems, this flexibility means that sacrifices in efficiency will be limited to those needed for proper system performance. The LT1533 is the switching regulator of choice for high performance analog systems. 

LT1635 1A Shunt Charger

by Mitchell Lee

Most battery chargers comprise nothing more than a series-pass regulator with current limit. In solar-powered systems, you can't count on sufficient headroom to keep a series regulator alive, so a shunt method is preferred. A simple shunt battery charger is shown in Figure 1. It consists of an op amp driving a shunt transistor and ballast resistor, and is built around an LT1635. This device contains both an op amp and a reference, making it perfectly suited for regulator and charger applications.

Operation is straightforward: the battery voltage is sensed by a feedback divider composed of two 1M resistors. The internal 200mV reference is amplified to 7.05V and compared against the feedback. R_{T1} introduces a TC that accurately tracks the battery's correct charging voltage

over a wide temperature range. Because R_{T1} is designed to compensate for changes in battery temperature, it should be located close to the battery and as far as possible from the shunt elements. When the battery charges to 14.1V, the op amp output begins to rise, turning on the Darlington shunt and resisting further increases in voltage. Full panel power is divided equally between the transistor and 7.5Ω resistor when the battery is completely charged. Don't forget to provide adequate heat sinking and air flow for up to 15W dissipation.

The charger is designed to handle 1A continuous, which is compatible with a "20W" panel. There is no need to disconnect or diode isolate the charger during periods of darkness, because the standby current is only

230μA—less than 10% of the self discharge of even a small battery.

If a different or adjustable output is desired, the feedback ratio can be easily modified at the 1M divider. 14.1V is a compromise between an aggressive charge voltage and a conservative float voltage. Given the cyclic nature of insolation, allowing periodic charging at 14.1V is not detrimental to Gelcell™ batteries. The circuit in Figure 1 will work with larger or smaller batteries than that shown. As a rule of thumb, the panel should be sized from 1W per 10Ah battery capacity (a float charge under good conditions with a good battery) to 5W per 1Ah battery capacity (1 day recharge of a completely discharged battery under favorable conditions of insolation). 

Gelcell is a trademark of Johnson Controls, Inc.

DESIGN IDEAS

LT1635 1A Shunt Charger22
Mitchell Lee

**Negative-to-Positive
Telecommunication Supply23**
Kurk Mathews

**Send Camera Power and Video
on the Same Coax Cable24**
Frank Cox

**MUX the LTC1419
Without Software25**
Kevin R. Hoskins

**Low Cost 3.3V to 1.xV 6 Amp
Power Supply26**
Sam Nork

**Short-Circuit-Proof Isolated
High-Side Switch27**
Mitchell Lee

**The LTC1590 Dual 12-Bit DAC
is Extremely Versatile28**
Kevin R. Hoskins

**12V Wall Cube to 5V/400mA DC/DC
Converter is 85% Efficient30**
Steve Pietkiewicz

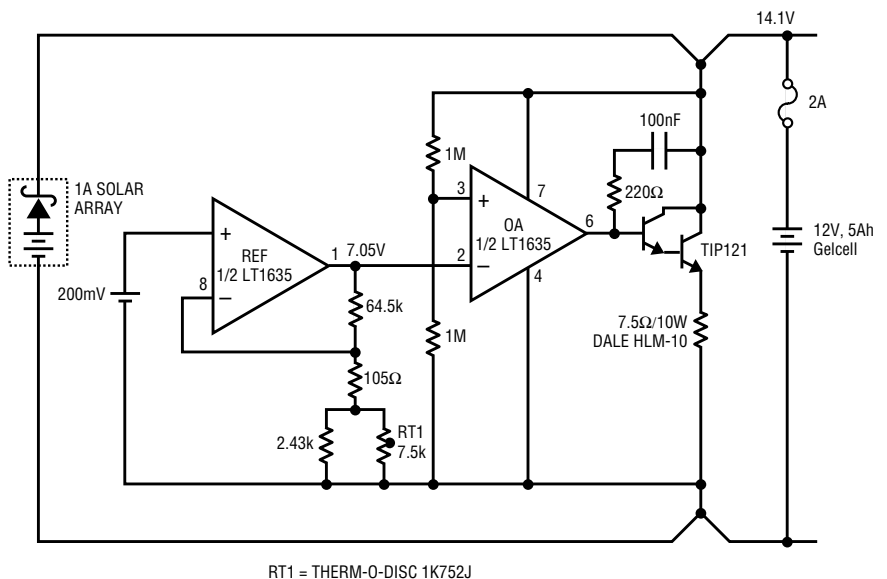

Figure 1. 1A shunt battery charger ($I_{DARK} = 230\mu A$; $V_{FLOAT} = 14.1V$)

Authors can be contacted
at (408) 432-1900

Negative-to-Positive Telecommunication Supply

by Kurk Mathews

An increasing number of telecommunication circuits require a positive supply voltage derived from a -48V input. The traditional approach to negative-to-positive conversion has been to use a buck-boost converter (see Figure 1). Unfortunately, this topology suffers drawbacks as the power level and input-to-output voltage difference increases.

A more appropriate solution for -48V to 5V conversion is shown in Figure 2. The LT1680 is used to implement a forward converter with its output referenced to the input common. Compared to the buck-boost converter, switch current is reduced by a factor of two and output capacitor ripple is reduced by a factor of five.

The LT1680 is referenced to -48V and requires a 12V bias supply. The

12V is generated by using the RUN/SHDN and a bootstrap winding on the output inductor, L1. When input voltage is first applied, R1 begins charging C1. As C1 charges, Q1 is held on by R2, shorting R3. R4 and R5 form a voltage divider that holds the RUN/SHDN pin below its 1.25V threshold until the 12V_{IN} pin reaches approximately 14V . Once out of standby, Q1 is turned off by Q2, reducing the run threshold to approximately 9V and allowing C1 time to discharge slightly before the overwinding on L1 takes over. The only remaining issue is feedback. Q3 translates the output voltage to a current, which flows to the V_{FB} pin.

The LT1680's unique differential current sense amplifier has an input common mode range of -0.3V to 60V .

If V_{IN} is expected to exceed 60V , the sense resistor could be relocated in the main FET's source and the input capacitors' voltage increased. Because the forward converter topology is fundamentally an isolated topology, an optocoupler and reference could be added to provide isolation between the input and output of the supply. 

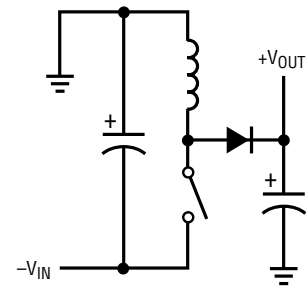

Figure 1. Buck/boost converter

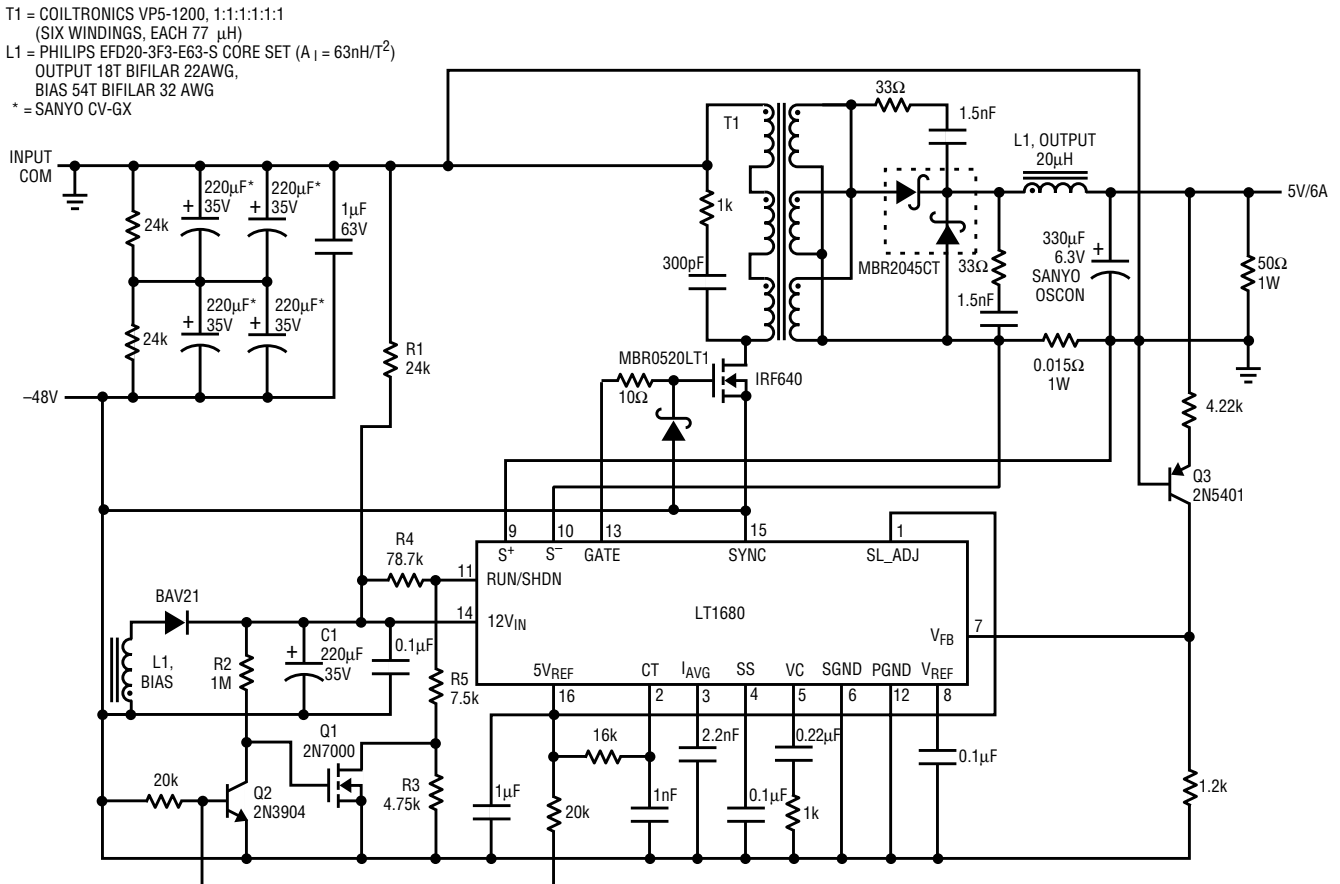

Figure 2. -48V to 5V Telecommunication supply

Send Camera Power and Video on the Same Coax Cable

by Frank Cox

Because remotely located video surveillance cameras do not always have a ready source of power, it is convenient to run both the power and the video signal through a single coax cable. One way to do this is to use an inductor to present a high impedance to the video and a low impedance to the DC. The difficulty with this method is that the frequency spectrum of a monochrome video signal extends down to at least 30Hz. The composite color video spectrum goes even lower, with components at 15Hz. This implies a rather large inductor. For example, a 0.4H inductor has an impedance of only 75Ω at 30Hz, which is about the minimum necessary. Large inductors have a large series resistance that

wastes power. More importantly, large inductors can have a significant amount of parasitic capacitance and stand a good chance of going into self resonance below the 4MHz video bandwidth and thus corrupting the signal. The circuit shown in Figure 1 takes a different approach to the problem by using all active components.

The circuitry at the monitor end of the coax cable supplies all the power to the system. U1, an LT1206 current feedback amplifier, forms a gyrator or synthetic inductor. The gyrator isolates the low impedance power supply from the cable by maintaining a reasonably high impedance over the video bandwidth while, at the same time, contributing only 0.1Ω of series resis-

tance. This op amp needs to have enough bandwidth for video and sufficient output drive to supply 120mA to the camera. The selected part has a guaranteed output current of 250mA and a 3dB bandwidth of 60MHz, making it a good fit. Because the video needs to be capacitively coupled, there is no need for split supplies; hence a single 24V supply is used. The 24V supply also gives some headroom for the voltage drop in long cable runs.

The camera end has an LT1086 fixed 12V regulator (U3) to supply 12V to a black and white CCD video camera. U4, an LT1363 op amp, supplies the drive for Q1, a fast, high current transistor. Q1, in turn, modulates the video on the 20V DC. The

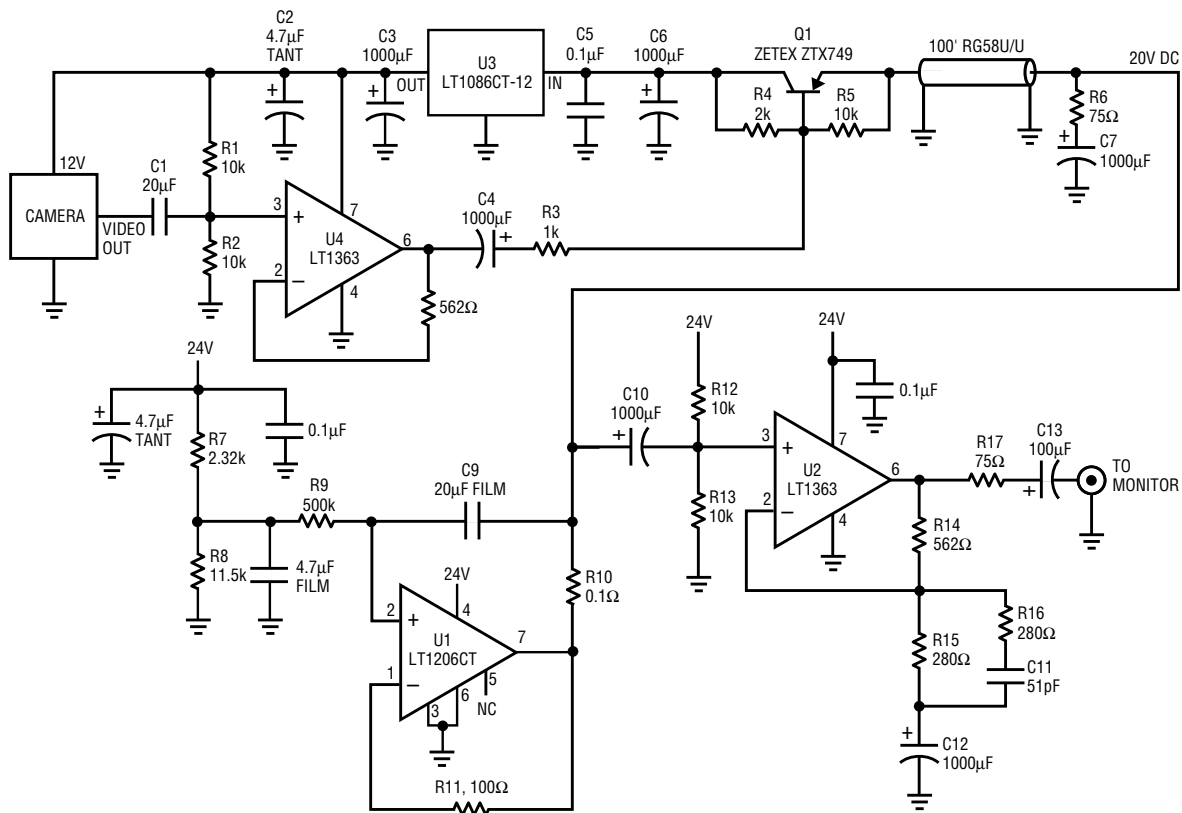



Figure 1. Circuit transmits video and 12V power on the same coax cable

collector of Q1 is the input to the 12V regulator. This point is AC ground because it is well bypassed as required by U3. U1 is set up to deliver 20V to the cable. Because the 12V regulator in the camera end needs 1.5V of dropout voltage, the balance of 6.5V can be dropped in the series

resistance of the cable. The output of the LT1206 is set to 20V to give headroom between the supply and the video.

U2, another LT1363 video-speed op amp, receives video from the cable, supplies some frequency equalization

and drives the cable to the monitor. Equalization is used to compensate for high frequency roll off in the camera cable. The components shown (R16, C11) gave acceptable monochrome video with 100 feet of RG58 B/U cable. 

MUX the LTC1419 Without Software

by Kevin R. Hoskins

The circuit shown in Figure 1 uses hardware instead of software routines to select multiplexer channels in a data acquisition system. The circuit features the LTC1419 800ksp/s 14-bit ADC. It receives and converts signals from a 74HC4051 8-channel multiplexer. Three of the four output bits from an additional circuit, the 74HC4520 dual 4-bit binary counter, are used to select a multiplexer channel. A logic high power-on or processor-generated reset is applied to the counter's pin 7.

After the counter is cleared, the multiplexer's channel selection input is 000 and the input to channel 0 is applied to the LTC1419's S/H input. The channel-selection counter is clocked by the rising edge of the convert start (CONVST) signal that initiates a conversion. As each CONVST pulse increments the counter from 000 to 111, each multiplexer channel is individually selected and its input signal is applied to the

LTC1419. After each of the eight channels has been selected, the counter rolls over to zero and the process repeats. At any time, the input multiplexer channel can be reset to 0 by applying a logic-high pulse to pin 7 of the counter.

This data acquisition circuit has a throughput of 800ksp/s or 100ksp/s/channel. As shown in Figure 2, the SINAD is 76.6dB for a full-scale $\pm 2.5V$, 1.19kHz sine wave input signal. 

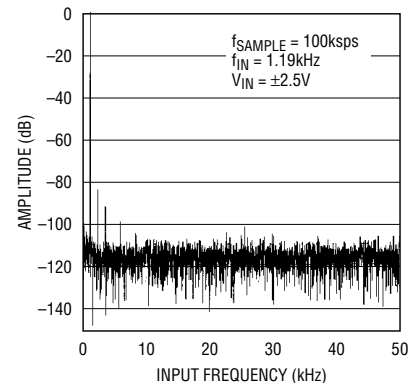
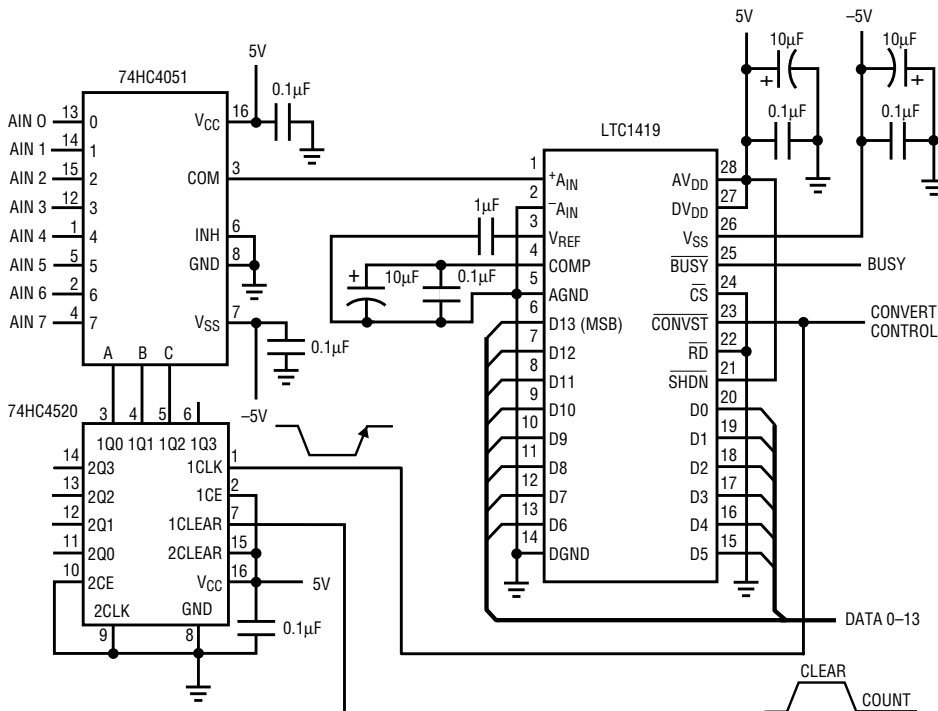

Figure 2. FFT of the MUXed LTC1419's conversion of a full-scale 1.19kHz sine wave

Figure 1. This simple stand-alone circuit requires no software to sequentially sample and convert eight analog signal channels at 14-bit resolution and 100ksp/s/channel.

Low Cost 3.3V to 1.xV 6 Amp Power Supply

by Sam Nork

As voltage requirements for micro-processors drop, the need for high power DC/DC conversion from a 3.xV supply to a lower voltage keeps growing. The LTC1430 is a very attractive choice for such DC/DC applications, due to its low cost, high efficiency and high output power capability. However, there are two problems: first, 3.xV does not provide enough gate drive to ensure low $R_{DS(ON)}$ using external logic-level FETs; and second, the LTC1430 has a 4V minimum input requirement. These obstacles are both overcome by using an LTC1517-5 regulated charge pump to generate the input voltage for the LTC1430.

The circuit shown in Figure 1 uses the LTC1430 to produce a synchronous 3.3V to 1.9V step-down DC/DC converter. The circuit achieves 90.5% efficiency at 3 amps of output current and has a 6 amp maximum output capability. (Refer to the LTC1430 data sheet for detailed description of LTC1430-based designs). Power for

the LTC1430 is derived from the output of the LTC1517-5.

The LTC1517-5 is a switched capacitor charge pump available in a tiny, 5-pin SOT-23 package. The part uses Burst Mode operation to generate a 5V output from a 2.7V to 5V input. It achieves regulation by sensing the output voltage via an internal reference, comparator and resistor divider (see Figure 3). When the output has dropped below the lower trip point of the comparator, the charge pump is enabled, boosting V_{OUT} back above the upper trip point. The LTC1517-5 also contains thermal-shutdown and short-circuit protection.

The regulated 5V supply powers the internal circuitry of the LTC1430 and ensures that the LTC1430 can provide adequate gate drive to the external N-channel FETs. With insufficient gate drive, output power and efficiency will be significantly reduced due to high $R_{DS(ON)}$ of the FETs. In this circuit, typical supply

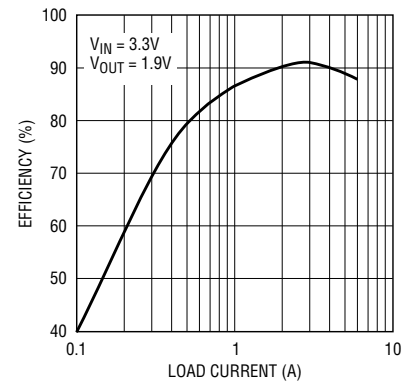

Figure 2. Efficiency curve for Figure 1's circuit

current drawn by the LTC1430 is between 25mA and 30mA, the vast majority of which is needed to charge and discharge the external FETs. Because the LTC1517-5 has a maximum effective output impedance of 50Ω, this current can be comfortably supplied from a 3.3V input. If the input voltage drops to 3V or lower, the LTC1517-5 output may also drop. However, with the FETs shown in Figure 1, the LTC1517-5 will provide a 4.5V minimum supply to the LTC1430 at input voltages down to 3V.

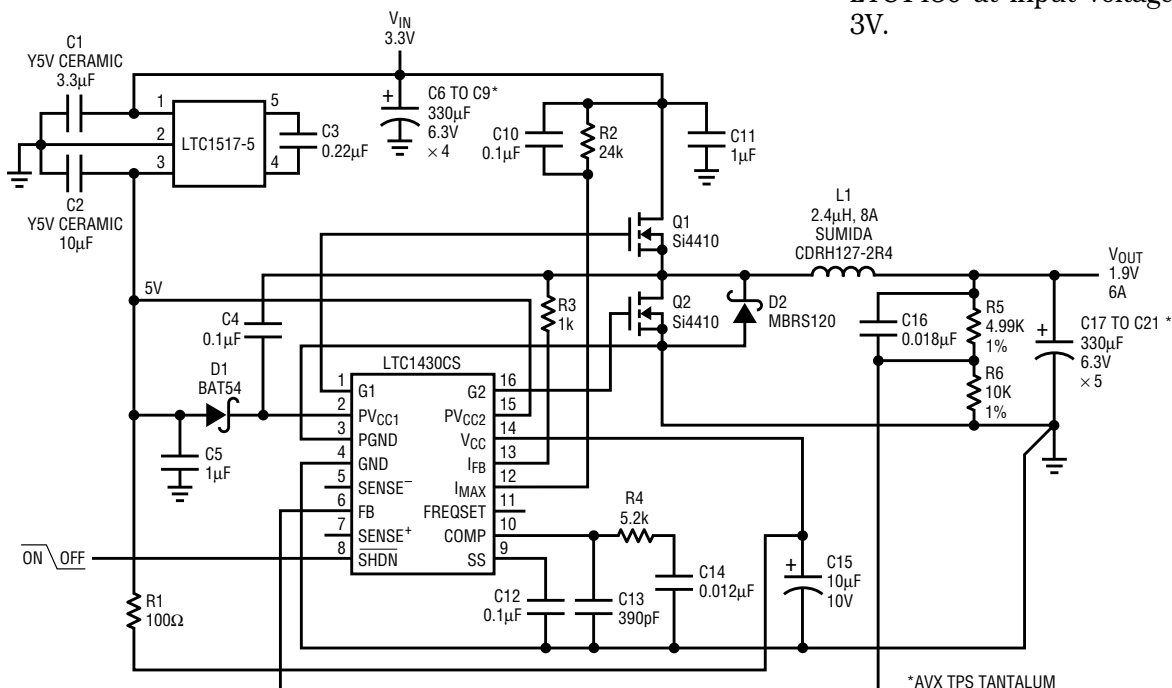



Figure 1. 3.3V to 1.9V/6A power supply

Pulling the $\overline{\text{SHDN}}$ pin on the LTC1430 low will shut down the power supply. Q1 and Q2 will be forced off and the LTC1430 quiescent current will drop to $1\mu\text{A}$. Although the LTC1517-5 does not have a shutdown feature, the no-load operating current is an extremely low $6\mu\text{A}$. This keeps the overall shutdown current below $10\mu\text{A}$ plus external FET leakage. (For further reductions in shutdown current, an 8-pin LTC1522 may be used in place of the LTC1517-5; the LTC1522 is the same as an LTC1517-5 with shutdown.) The additional LTC1517-5 circuitry will not take up much board space. The entire circuit consumes only 0.045 in^2 . 

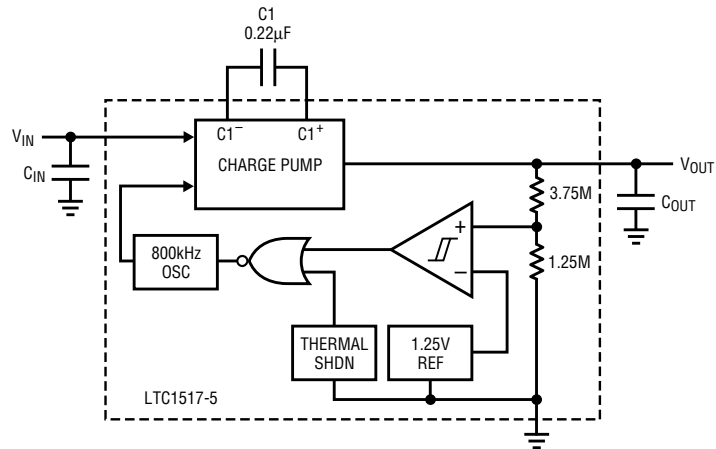

Figure 3. LTC1517-5 simplified block diagram

Authors can be contacted
at (408) 432-1900

Short-Circuit-Proof Isolated High-Side Switch

by Mitchell Lee

Figure 1 shows a MOSFET switch, driven by the LTC1177-5 $2.5\text{kV}_{\text{RMS}}$ isolator. This device allows a logic signal to control a power MOSFET and provides complete galvanic isolation. The device includes an internal current limiting circuit, but at higher voltages limiting the current is just not enough for effective protection of the MOSFET. Foldback (shown on the LTC1177 data sheet) helps, but the part has trouble starting certain types of loads when foldback current limiting is used. The circuit shown here latches off in an overcurrent condition and is restarted by cycling the logic input.

Q1 and Q2 form an SCR with a holding current of less than 100nA . If the load current exceeds approximately 1A , the SCR fires, shorting the MOSFET gate to source. The LTC1177 output current (about $7\mu\text{A}$) is more than adequate to hold the SCR on

indefinitely. The circuit resets when the logic input briefly cycles off.

Inductive loads present a special problem. If the load creeps up on the overcurrent threshold and fires the SCR, the load's inductance will carry the MOSFET source far below ground, which could destroy the MOSFET. Diode D1 clamps the gate at ground,

turning the MOSFET back on, and safely dissipates the stored magnetic energy in the MOSFET.

As shown the output rise time is about 2ms , allowing the circuit to successfully charge capacitors of up to $100\mu\text{F}$. Increase C1 proportionately to handle higher value load capacitors. 

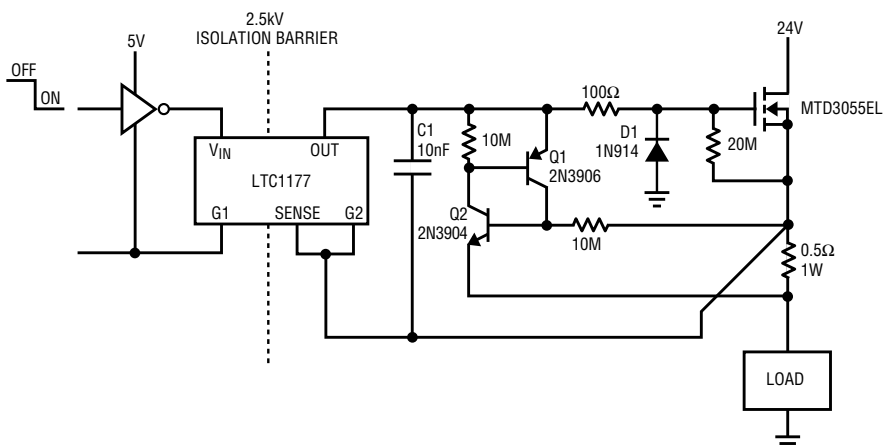

Figure 1. Short-circuit protected, isolated high-side switch

The LTC1590 Dual 12-Bit DAC is Extremely Versatile

by Kevin R. Hoskins

CMOS multiplying DACs make versatile building blocks that go beyond their basic function of converting digital data into analog signals. This Design Idea details some of the other circuits that are possible when using the LTC1590 dual, serially interfaced 12-bit DAC.

The circuit shown in Figure 1 uses the LTC1590 to create a digitally controlled attenuator using DAC_A and a programmable gain amplifier (PGA) using DAC_B. The attenuator's gain is set using the following equation:

$$V_{OUT} = -V_{IN} \frac{D}{2^n}$$

where V_{OUT} = output voltage
 V_{IN} = input voltage
 n = DAC resolution in bits
 D = value of code applied to DAC

The attenuator's gain varies from 4095/4096 to 1/4096. A code of 0 can be used to completely attenuate the input signal.

The PGA's gain is set using the following equation:

$$V_{OUT} = -V_{IN} \frac{2^n}{D}$$

where V_{OUT} = output voltage
 V_{IN} = input voltage
 n = DAC resolution in bits
 D = value of code applied to DAC

The gain is adjustable from 4096/4095 to 4096/1. A code of 0 is meaningless, since this results in infinite gain and the amplifier operates open loop. With either configuration, the attenuator's and PGA's gain are set with 12 bits accuracy.

Further modification to the basic attenuator and PGA is shown in Figure 2. In this circuit, DAC_A's attenuator circuit is modified to give the output amplifier a gain set by the ratio of resistors R3 and R4. The

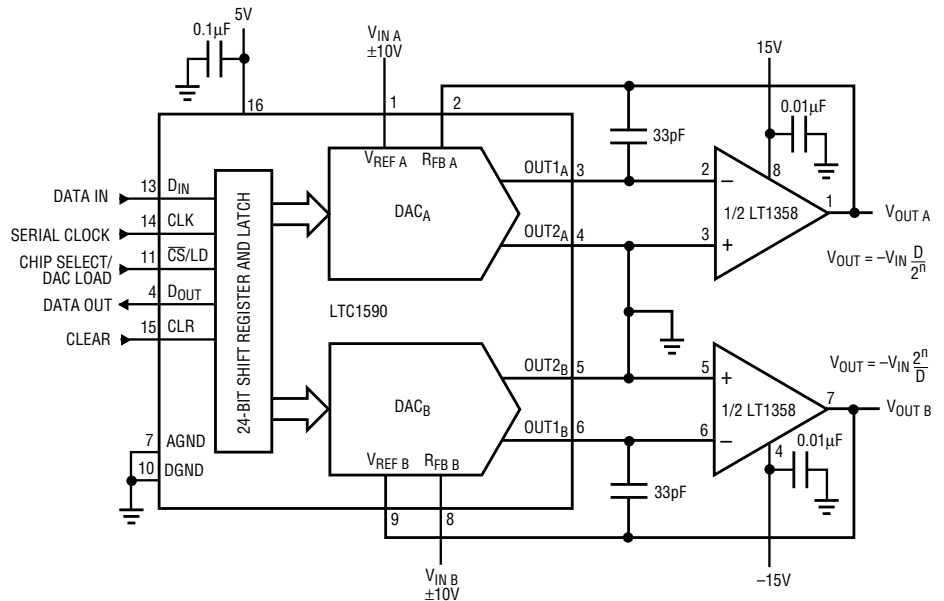

Figure 1. Driving DAC_A's reference input (V_{REF}) and tying the feedback resistor (R_{FB}) to the op amp's output creates a 12-bit accurate attenuator. Reversing the V_{REF} and R_{FB} connections configures DAC_B as a programmable-gain amplifier.

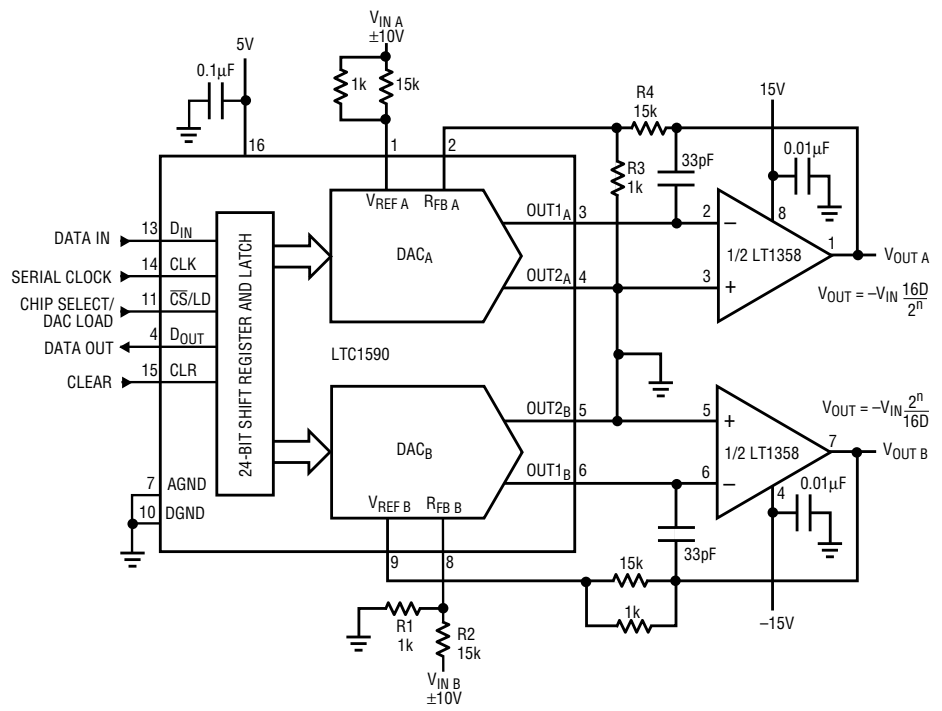

Figure 2. Modifying the basic attenuator and PGA creates gain for the attenuator (R3 and R4) and attenuation at the PGA's input (R1 and R2).

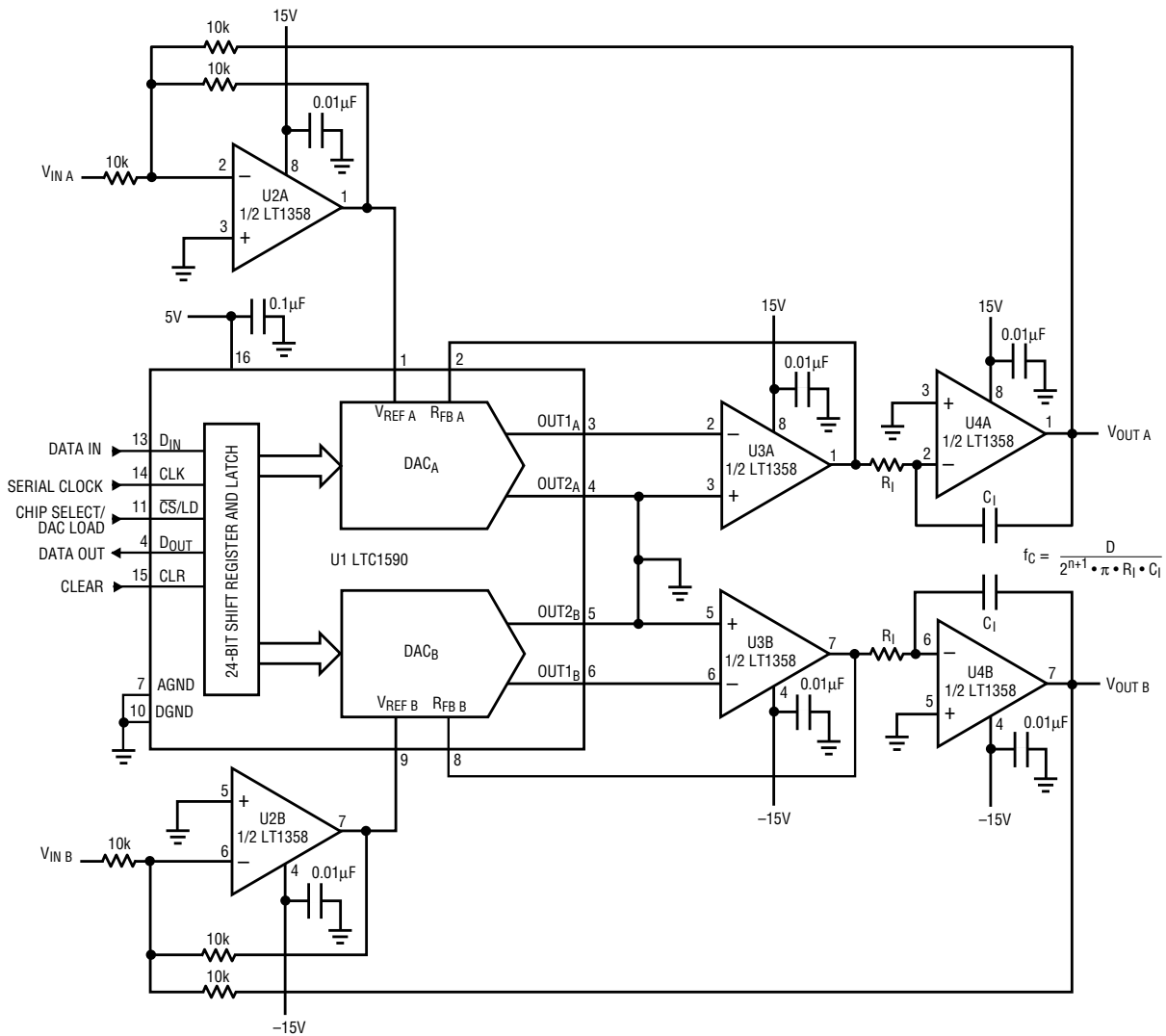

Figure 3. This LTC1590-controlled dual single-pole lowpass filter uses R_1 and the DAC's input code to create an effective resistance that sets the integrator's time constant and, therefore, the circuit's cutoff frequency.

equation for this attenuator with output gain is

$$V_{OUT} = -V_{IN} \frac{16D}{2^n}$$

With the values shown, the attenuator's gain has a range of $-1/256$ to -16 . This range is easily modified by changing the ratio of R_3 and R_4 . In the other half of the circuit, an attenuator has been added to the input of DAC_B , configured as a PGA. The equation for this PGA with input attenuation is

$$V_{OUT} = -V_{IN} \frac{2^n}{16D}$$

This sets the gain range from effectively $-1/16$ to -256 . Again, this range

can be modified by changing the ratio of R_1 and R_2 .

The LTC1590 can also be used as the control element that sets a lowpass filter's cutoff frequency. This is shown in Figure 3. The DAC becomes an adjustable resistor that sets the time constant of the integrator formed by U4 and C_1 . With the integrator enclosed within a feedback loop, a lowpass filter is created.

The cutoff frequency range is a function of the DAC's resolution and the digital data that sets the effective resistance. The effective resistance is

$$R_{REF} = R_1 \frac{2^n}{D}$$

Using this effective resistance, the cutoff frequency is

$$f_c = \frac{D}{2^{n+1} \cdot \pi \cdot R_1 \cdot C_1}$$

The cutoff frequency range varies from $0.0000389/RC$ to $0.159/RC$. As an example, to set the minimum cutoff frequency to 10Hz, make $R_1 = 8.25k$ and $C_1 = 470pF$. At an input code of 1, the cutoff frequency is 10Hz. The cutoff frequency increases linearly with increasing code, becoming 40.95kHz at a code of 4095. Generally, as the code changes by ± 1 bit, the cutoff frequency changes by an amount equal to the frequency at $D = 1$. In this example, the cutoff frequency changes in 10Hz steps. 

12V Wall Cube to 5V/400mA DC/DC Converter is 85% Efficient

by Steve Pietkiewicz

The ubiquitous 12V wall cube, power source of countless electronic products, generates an unregulated DC voltage between 8V and 18V, depending on line voltage and load. If you use a linear regulator to drop the voltage to 5V, a 400mA load means the linear regulator must dissipate 5W under worst-case conditions. To deal with this heat, you must provide adequate heat sinking, increasing your product's size and weight. Additionally, the heat is sometimes objectionable to customers. These factors can negate the cost advantage of a linear regulator. Figure 1's circuit, a negative buck converter, delivers 5V at loads up to 400mA from

a 7V–25V input with peak efficiency of 85%, eliminating the need for a heat sink. Since the LT1307B (U1) is intended for use with a low input voltage, Q1 and Q2 are used to make a simple preregulator, providing 1.9V for U1's V_{IN} pin. The IC switches at 600kHz, allowing a low cost 22 μ H inductor and 10 μ F ceramic output capacitor to be used. Q3 is needed to level shift the output voltage because U1's feedback pin is referenced to the negative input. Output ripple measures 10mV_{P-P} at a load of 400mA. The circuit's efficiency is detailed in Figure 2, and response to a load step from 150mA to 300mA is shown in

Figure 3. Input bypass capacitor C1 sees worst-case RMS ripple current equal to one-half the output current and should have an ESR of less than 0.5 Ω . Take care during construction to keep R1–R3 and Q3 close to U1's FB pin and away from the SW pin to prevent unwanted coupling. Use a ground plane and keep traces for the power components short and direct.

Although it might seem unsettling that the negative side of the wall cube is not grounded, remember that the 9V wall cube floats. The circuit merely regulates the negative side, rather than the more conventional positive side. 

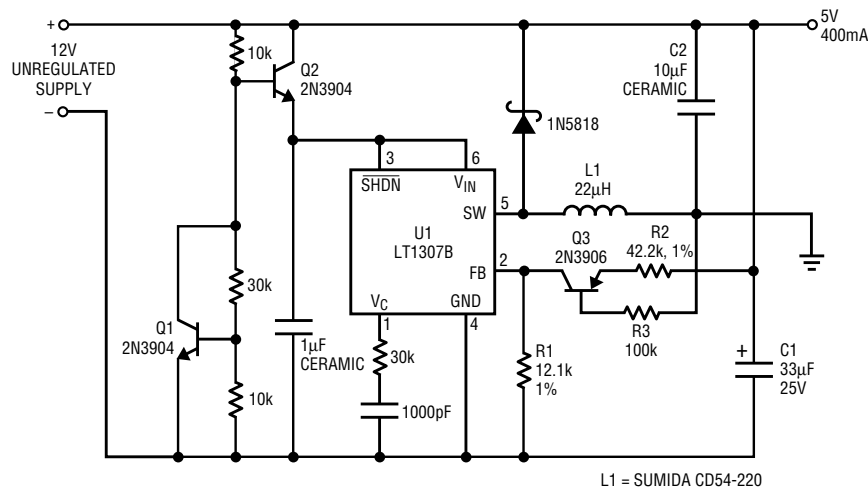

Figure 1. This negative buck converter delivers 5V at 400mA from a 7V–25V input.

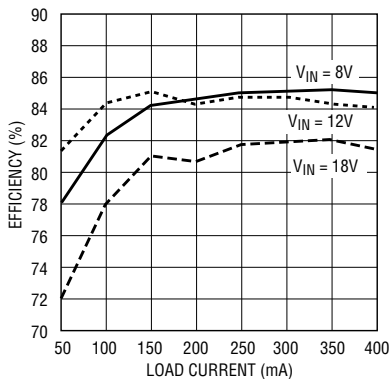

Figure 2. Efficiency peaks at 85%; it is above 80% over an input range of 8V–18V.

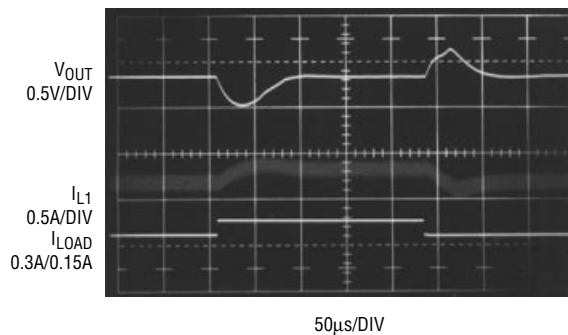

Figure 3. Load-step response; the load changes from 150mA to 300mA.

Understanding and Applying Voltage References (Part Two)

by Mitchell Lee

Board Leakage

A new specter has entered the field of references: board leakage caused by the residues of water-soluble flux. The effect is not unlike that produced by the sticky juice extravasated from a ruptured electrolytic capacitor. Leakage from ground, supply rails and other circuit potentials into NC, trim and other sensitive pins through conductive flux residues will cause output voltage shifts. Even if the leakage paths do not shift the reference out of spec, external leakage can manifest itself as long-term output voltage drift, as the resistance of the flux residue changes with shifts in relative humidity and the diffusion of external contaminants. Water-soluble flux residues must be removed from the board and package surfaces, or completely avoided. In one case, the author observed an LT1009 shifted out of spec by a gross leakage path of approximately 80k Ω between the trim pin and a nearby power supply trace. The leakage was traced to water-soluble flux.

Figure 8 shows how a good reference can go bad with only a very small leakage. A hypothetical industrial control board contains an LT1027A producing 5V for various data acquisition circuits. A nearby trace carries 24V. Just 147M Ω leakage into the noise filtering pin (NR) causes a typical device to shift +200ppm, and out of spec. Clearly, a 24V circuit trace

doesn't belong anywhere near a 0.02% reference. This example is oversimplified but clearly demonstrates the potential for disaster.

A tightly packed circuit board may leave no choice but to agglomerate incompatible traces. In this case, use a guard ring to eliminate reference shift (see Figure 9). The output of the reference is divided down to 4.4V, equal to the potential on the NR pin, and used to bias a guard ring encircling the trace connecting NR to the noise filter capacitor. This reduces the effect of board leakage paths by more than two orders of magnitude, shunting the errant leakage away from the guarded traces.

Trim-Induced Temperature Drift

About half of LTC's reference offerings include a pin for external (customer) trimming. Trimming may be necessary to calibrate the system, but it can also adversely affect the tempco of the reference. For example, in the LT1019 bandgap reference, external trim resistors won't match the tempco of the internal resistors. The mismatch causes a small (1ppm/ $^{\circ}$ C) worst-case shift in the output voltage tempco, as explained on the data sheet. The LT1021-5 and LT1236-5 standard trim circuit can be modified, as shown in Figure 10, to prevent upsetting the references'

inherently low temperature coefficients. Trimming the LT1027 has little effect on the output voltage tempco, and it needs no special consideration. Always check the reference data sheet for specific recommendations.

Burn-In

Most manufacturers of high-accuracy systems run their products through a burn-in procedure. Burn-in solves two problems at once: it relieves stresses built into the reference and circuit board during assembly and it ages the reference beyond the highest long-term drift region, which occurs when power is first applied to the part. A typical burn-in procedure calls for operating the board at 125 $^{\circ}$ C ambient for 168 hours. If the main concern is stress relief, a shorter, unpowered burn-in cycle can be used.

Board Stress

Burn-in can help "relax" a stuffed board, but additional mechanical stress may be introduced when the board is mounted into the product. Stress has a directly measurable effect on reference output. If the stress changes over a period of time, it may manifest itself as unacceptable long-term drift. Circuit boards are not perfectly elastic, so bending forces may cause permanent deformation and a permanent step-change in reference output voltage. Devices in

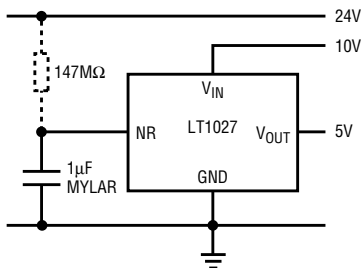

Figure 8. Board leakage can wreak havoc with a precision reference. Here, a 147M Ω leakage path to 24V pushes the 5V output out of spec.

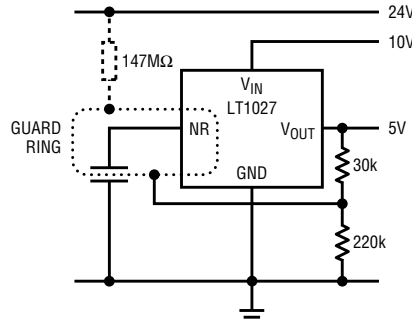

Figure 9. Adding a guard ring protects against errant leakage paths.

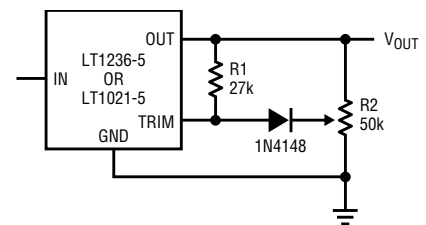

Figure 10. The LT1021 or LT1236 output trim is made temperature insensitive by the addition of a diode and a resistor.

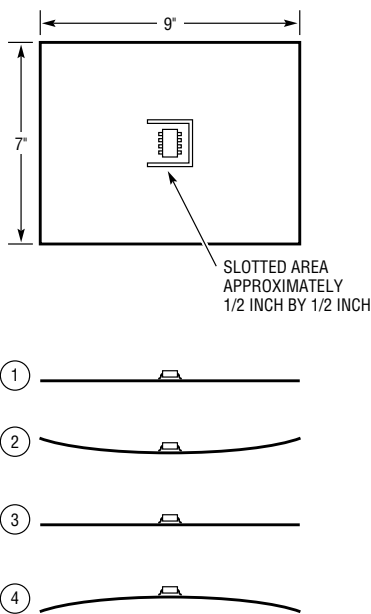

Figure 11. Reference sensitivity to stress was evaluated by assembling devices on a 7" x 9" circuit board and flexing, as shown in steps 1-4.

metal (TO-5 and TO-46) packages are largely immune to board stress, owing to the rigidity of the package and the flexibility of the leads. Plastic and surface mount packages are another matter.

Board stress effects are easily observed by monitoring the output of a reference while applying a bending force to the board. A controlled experiment was performed to measure the effect of board stress on an LT1460CS8-2.5 surface mount reference. Devices were mounted in the center of 7" x 9" rectangular boards, as shown in Figure 11. The boards were then deflected out-of-plane 18 mils per inch, as shown in steps 1 through 4. Figure 12 shows the net effect on the output of one representative sample measured over eight cycles of flexure.

The original board showed about 60ppm peak-to-peak shift. The board was then slotted on a vertical mill, forming a 0.5" x 0.5" tab with the reference located in its center (also illustrated in Figure 11). The test continued with the slotted configuration, and the output voltage variations were reduced to ± 1 count (10 μ V) on the meter, or approximately 4ppm peak-

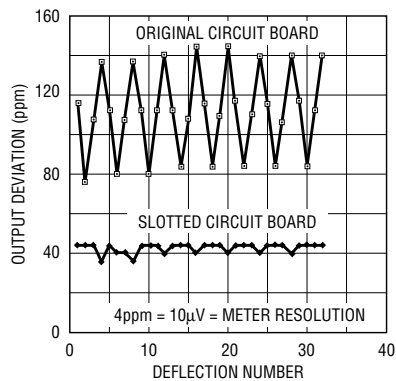

Figure 12. Isolating stress by slotting the circuit board reduces reference variations by more than an order of magnitude.

to-peak. This represents a tenfold improvement in stress-induced output voltage shift.

Several other techniques can be employed to minimize this effect, without resorting to a milled board. Anything that can be done to restrict the board from bending is helpful. A small, thick board is better than a large, thin board. Stiffeners help immunize the board against flexure. Mount the circuit board with grommets, flexible standoffs or card-cage style so that minimal force is applied to the mounting holes and board.

Part placement and orientation are just as important. If a board is squeezed from opposite edges, the bending force tends to concentrate in a line down the center. Locate the reference away from the middle of the board. Since the longer side of a board is more flexible than the shorter, locate the reference along the shorter edge. These recommendations are generalities; the placement, mounting method and orientation of other components and assemblies on the circuit board will influence the mechanical strengths and weaknesses of the circuit board.

Bench tests indicate that the strongest axis for plastic packages is along the shorter dimension of the body of the plastic. Figure 13 shows the correct orientation for surface mount parts. Note that the part's longest axis is placed perpendicular to that of the circuit board. The devices in Figure 13 are shown in the center of the board for illustrative

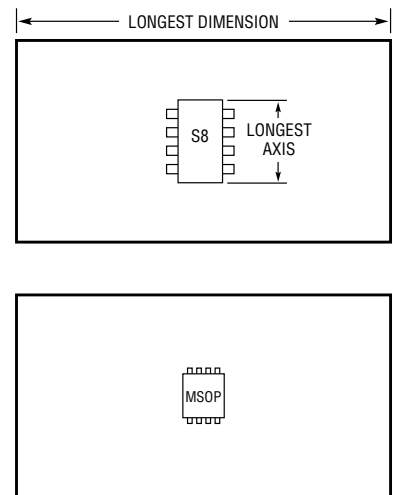

Figure 13. Arranging the longest axes of the board and package in perpendicularity minimizes stress-induced output changes.

purposes only; comments about placement still apply.

In spite of all precautions, extraneous effects may adversely affect the reference's resistance to board stress. Watch out for adhesives and solder and flux debris under the package. These will create pressure points and induce unpredictable stresses in the package. If a board has been subjected to a high bending force, some of the glass fibers and layers may break or shear apart, permanently weakening the board. Subsequent bending forces will concentrate their stress at points thus weakened.

Figure 14 shows various schemes for routing stress-relief slots on a circuit board, along with optimum package orientation. Note that the longest axis of the reference is aligned with the tab, not the shortest axis of the circuit board. This is in

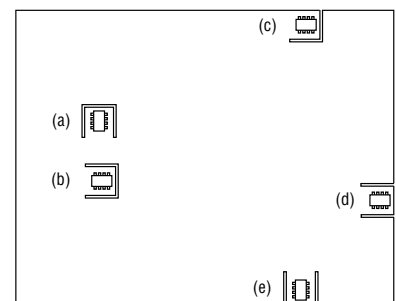

Figure 14. Slotting the area around the reference can help isolate it from board stress if properly applied (see text).



Figure 15. Air turbulence induces low frequency noise and compromises reference accuracy.

anticipation of flexing forces transmitted into the tab. The best orientation for the tab is in line with the longest axis of the board as in (b), (c) and (d). Bending forces along the weaker (longer) axis of the board could be coupled into (a) and (e). Note that

the ICs are aligned to resist this force. Use configuration (c) when the part is located along the longer edge of the board, and (d) when it is located along the shorter edge. Use (b) when the part is not located along any edge.

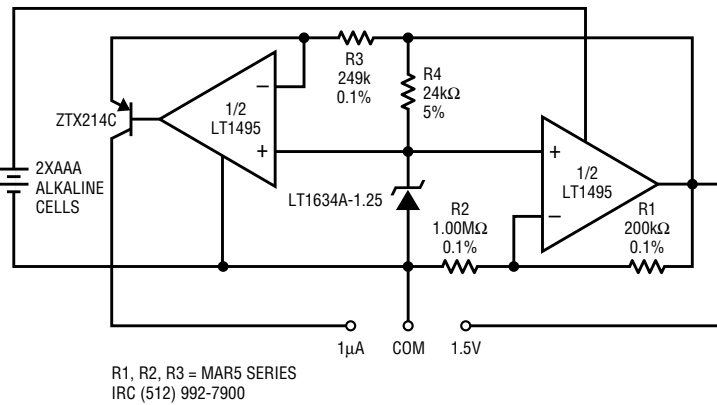

Figure 16. This pocket reference operates for five years on one set of AAA cells.

Temperature-Induced Noise

Even though references operate on very meager supply currents, dissipation in the reference is enough to cause small temperature gradients in the package leads. Variations in thermal resistance, caused by uneven air flow, lead to differential lead

Table 3. Guaranteed supply current (mA) over temperature

Part	Bandgap	Buried Zener	Mode***	1.25V	2.5V	4.5V	5.0V	7.0V	10V
LT1004	✓		shunt	0.01	0.02				
LT1009	✓		shunt		0.4				
LT1019	✓		series		1.5	1.5	1.5		1.5
LT1019A					1.3	1.3	1.3		1.3
LT1021		✓	series				1.5	1.5	2.0
LT1027		✓	series				2.8		
LT1029	✓		shunt				0.6		
LT1031		✓	series						2.0
LT1034	✓	*	shunt	0.02	0.02			0.1*	
LT1236		✓	series				1.5		1.5
LT1460	✓		series		0.165		0.165		0.165
LT1634	✓		shunt	0.012					
LT1634A				0.012					
LTZ1000		✓	shunt					1.1**	

*The LT1034 dual reference includes both a bandgap and a buried Zener

**Does not include heater current; recommended Zener current 5mA

***Current for shunt references is minimum operating current; for series references it is maximum quiescent current.

Table 4. Guaranteed percentage initial accuracy at 25°C

Part	Bandgap	Buried Zener	Mode	1.25V	2.5V	4.5V	5.0V	7.0V	10V	
LT1004	✓		shunt	0.32	0.81					
LT1009	✓		shunt		0.2					
LT1019	✓		series		0.2	0.2	0.2		0.2	
LT1019A		✓	series		0.05	0.05	0.05		0.05	
LT1021B		✓	series				1.0	0.7	0.5	
LT1021C						0.05		0.05		
LT1021D								1.0	0.7	0.5
LT1027A		✓	series				0.02			
LT1027B							0.05			
LT1027C							0.05			
LT1027D							0.05			
LT1027E								0.1		
LT1029	✓		shunt				1.0			
LT1029A						0.2				
LT1031B		✓	series						0.05	
LT1031C										0.1
LT1031D										0.2
LT1034	✓	*	shunt	1.2	1.6			4.3, -2.9		
LT1236A		✓	series				0.5		0.5	
LT1236B, C								0.1		0.1
LT1460A		✓	series		0.075		0.075		0.075	
LT1460B, C, D					0.1		0.1		0.1	
LT1460E					0.125		0.125		0.125	
LT1460F					0.125		0.15		0.15	
LT1460G					0.25		0.25		0.25	
LT1634,A	✓		shunt	0.1						
LTZ1000		✓	shunt					4.2, -2.8		

*The LT1034 dual reference includes both a bandgap and a buried Zener reference

Table 5. Temperature coefficient (ppm/°C)

Part	Bandgap	Buried Zener	Mode	Temperature Range	1.25V	2.5V	4.5V	5.0V	7.0V	10V
LT1004	✓		shunt	0°C–70°C	75**	75**				
				–55°C–125°C	75**	75**				
LT1009	✓		shunt	0°C–70°C		25				
				–55°C–125°C		35				
LT1019	✓		series	0°C–70°C		20	20	20		20
				–40°C–85°C		20	20	20		20
				–55°C–125°C		25	25	25		25
LT1019A				0°C–70°C		5	5	5		5
				–55°C–125°C		10	10	10		10
LT1021B		✓	series	$T_{MIN} \leq T_J \leq T_{MAX}$				5	5	5
LT1021C							20		20	
LT1021D							20	20	20	
LT1027A		✓	series	$T_{MIN} \leq T_J \leq T_{MAX}$				2		
LT1027B								2		
LT1027C								3		
LT1027D								5		
LT1027E								7.5		
LT1029	✓		shunt	0°C–70°C				34		
				–55°C–125°C				40		
LT1029A				$T_{MIN} \leq T_J \leq T_{MAX}$				20		
LT1031B	✓		series	$T_{MIN} \leq T_J \leq T_{MAX}$						5
LT1031C										15
LT1031D										25
LT1034	✓	*	shunt	$T_{MIN} \leq T_J \leq T_{MAX}$	40	40			40 (typ)	
LT1034B					20	20		40 (typ)		
LT1236A		✓	series	$T_{MIN} \leq T_J \leq T_{MAX}$				5		5
LT1236B								10		10
LT1236C								15		15
LT1460A, B	✓		series	$T_{MIN} \leq T_J \leq T_{MAX}$		10		10		10
LT1460C						15		15		15
LT1460D, E						20		20		20
LT1460F, G						25		25		25
LT1634	✓		shunt	$T_{MIN} \leq T_J \leq T_{MAX}$	20					
LT1634A					10					
LTZ1000		✓	shunt	$T_J = 65^\circ\text{C}$					0.1	

*The LT1034 dual reference includes both a bandgap and a buried Zener reference

**Absolute output voltage over temperature guaranteed; tempco is estimated for purposes of comparison

temperatures, thereby causing thermoelectric voltage noise at the output of the reference. Figure 15 dramatically demonstrates this effect. The first half of the plot was made with an LT1021H-7 buried Zener reference, which was shielded from ambient air with a small foam cup (Dart Container Corporation Stock No. 8J8 or similar). The cup was removed at six minutes elapsed time for the second half of the test. Ambient in both cases was a lab bench-top with no excessive turbulence from air conditioners, opening/closing doors, foot traffic or 547 exhaust. Removing the foam cup increased the output noise by almost an order of magnitude in the 0.01Hz to 10Hz band.

The kovar leads of the TO-5 working against copper circuit traces are the primary culprit. Copper lead frames used on DIP and surface mount packages are not nearly as sensitive to air turbulence because they are intrinsically matched. Still, external components create thermocouples of their own with potentials of $10\mu\text{V}/^\circ\text{C}$ or more per junction. In a LT1021-7 reference, this represents more than 1ppm/ $^\circ\text{C}$ shift from each thermoelectric generator. Temperature gradients across the circuit board and dissipation within external components can

lead to the same kind of noise as was shown in Figure 15.

Temperature gradients may arise from heat generators on the board. Position the reference and its associated external components far from heat sources and, if necessary, use routing techniques to create an isothermal island around the reference circuitry. Minimize air movement either by adding a small enclosure around the reference circuitry, or by encapsulating the reference circuitry in self-expanding polyurethane foam.

Reference Applications

The unique pocket reference shown in Figure 16 is a good match for a pair of AAA alkaline cells, because the circuit draws less than $16\mu\text{A}$ supply current. Two outputs are provided: a buffered, 1.5V voltage output, and a regulated $1\mu\text{A}$ current source. The current source compliance ranges from approximately 1V to -43V .

The reference is self-biased, completely eliminating line regulation as a concern. Start-up is guaranteed by the LT1495 op amp, whose output saturates at 11mV from the negative rail. Once powered, there is no reason to turn the circuit off. One AAA alkaline contains 1200mAh capacity, enough to power the circuit throughout the 5-year shelf life of the battery. Voltage output accuracy is about 0.17% and current output accuracy is about 1.2%. Trim R1 to calibrate the voltage (1k Ω per 0.1%), and R3 to calibrate the output current (250 Ω per 0.1%).

Low noise synthesizers need quiet power supplies for their VCOs and other critical circuitry. 3-terminal regulators exhibit far too much noise for this application, calling instead for a regulator constructed from a reference. A practical example is shown in Figure 17. Current through the LT1021-5 reference is used to drive the base of a PNP pass device, resulting in an available output current of at least 1A. In this example, the current is intentionally limited to 200mA by the addition of emitter degeneration and base clamping. The low noise of the reference is preserved,

giving a 100-fold improvement over the noise of an equivalent 5V, 3-terminal regulator, not to mention improved initial accuracy and long-term stability. Typical output noise is $7\mu\text{V}_{\text{P-P}}$ over a 10kHz bandwidth.

Conclusion

When specifying a reference, keep in mind that initial accuracy, temperature coefficient, and long-term stability all play a role in overall accuracy of the finished product. By taking some care in applying the reference, and by avoiding some key pitfalls, the reference's inherent accuracy can be preserved. Tables 3-5 compare quiescent current, initial accuracy and temperature coefficient for each of LTC's references.

For Further Reading

"The Ultra-Zener—A Portable Replacement for the Weston Cell?" by Peter J. Spreadbury; *IEEE Transactions on Instrumentation and Measurement*, Vol. 40, No. 2, April 1991, pages 343-346

Application Note 42: Voltage Reference Circuit Collection, by Brian Huffman; Linear Technology Corporation, June 1991.

Part one of this article appeared in the June 1997 issue of *Linear Technology*.

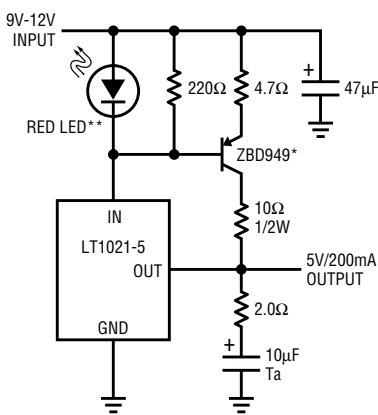

* ZETEX INC (516) 864-7630
 ** GLOWS IN CURRENT LIMIT. DO NOT OMIT.

Figure 17. Ultralow noise 5V, 200mA supply output noise is $7\mu\text{V}_{\text{RMS}}$ over a 10Hz to 10kHz bandwidth. Reference noise is guaranteed to less than $11\mu\text{V}_{\text{RMS}}$. Standard 3-terminal regulators have one hundred times the noise and no guarantees.



New Device Cameos

The LT1497: Dual 50MHz, 125mA Current Feedback Amplifier

The LT1497 dual 50MHz current feedback amplifier is ideal for driving twisted pairs, buffering low impedance loads and driving multiple back-terminated cables. The device features high output drive and low distortion from a modest supply current. From a low 7mA maximum supply current per amplifier, each output drives a minimum of $\pm 100\text{mA}$ to within 2V of each supply. Distortion at up to 1MHz is better than -70dBc driving $\pm 40\text{mA}$ peak signals into a 135Ω twisted pair.

Operation is fully specified for supplies from $\pm 2.5\text{V}$ to $\pm 15\text{V}$. The amplifiers have current and thermal limiting to provide protection against fault conditions. The LT1497 bridges the performance between the 30mA output, 100MHz LT1229 and the 250mA output, 60MHz LT1207 dual current feedback amplifiers.

The LT1497 is available in a low thermal resistance SO-16 package for operation with supplies up to $\pm 15\text{V}$. For operation at $\pm 5\text{V}$ and below, the device is also available in a low thermal resistance SO-8 package.

The LT1634: Micropower, Precision Voltage Reference

The LT1634 is LTC's newest micropower, precision, shunt voltage reference. The LT1634 provides excellent precision and drift performance at micropower bias currents. A low operating current of $10\mu\text{A}$, guaranteed temperature drift of $25\text{ppm}/^\circ\text{C}$, tight initial voltage accuracy of 0.05% are some of the virtues of the LT1634. The LT1634 comes in four popular voltages: 1.25V, 2.50V, 4.096V and 5.0V.

The bandgap reference uses trimmed precision thin-film resistors to achieve 0.05% initial voltage accuracy. Advances in design, processing and packaging guarantee $10\mu\text{A}$ operation and low temperature-cycling

hysteresis. Improved curvature correction techniques guarantee 25ppm maximum temperature drift. Board space is minimized with surface mount SO-8 and MSOP and through-hole TO-92 (Z) packages. To further reduce board space, the LT1634 requires no output compensation capacitor: it is stable with any capacitive load over the full operating current range of $10\mu\text{A}$ to 20mA .

The LT1634 is a high performance upgrade to the LM185/LM385, LT1004 and LT1034. The performance of the LT1634 makes it the ideal choice for applications where high precision and minimum power consumption are important. LT1634 is available in the commercial grade.

The LTC1659: Ultrasmall, 8-Lead MSOP Packaged, Low Power, 12-Bit Multiplying Voltage-Output DAC

The latest addition to LTC's family of 12-bit voltage-output DACs is the multiplying LTC1659. Packaged in an 8-lead MSOP, the LTC1659 operates on a single supply of 2.7V to 5.5V. The LTC1659 requires an external reference voltage source. The gain between the reference pin and the output is $V_{\text{IN}}(\text{CODE}/4096)$. For applications that require rail-to-rail output, connect V_{CC} to the reference pin for an output swing from GND to V_{CC} . The LTC1659 features a D_{OUT} pin that allows data daisy-chaining, and a simple 3-line (CLK, D_{IN} , $\overline{\text{CS}}/\text{LD}$) serial interface, allowing easy connection to microcontrollers and microprocessors.

The LTC1448: Dual Low Power, 12-Bit Multiplying, Voltage-Output DAC

The latest addition to LTC's family of dual 12-bit voltage-output DACs is the multiplying LTC1448. Packaged in an SO-8, the LTC1448 operates on a single supply of 2.7V to 5.5V. The LTC1448 requires an external refer-

ence voltage source. The gain between the reference pin and the output is $V_{\text{IN}}(\text{CODE}/4096)$. For applications that require rail-to-rail output, connect V_{CC} to the reference pin for an output swing from GND to V_{CC} . The LTC1448 features a simple 3-line (CLK, D_{IN} , $\overline{\text{CS}}/\text{LD}$) serial interface, allowing easy connection to microcontrollers and microprocessors.

The LTC1412: Low Power, 3Mps 12-Bit ADC

Adding to LTC's family of high speed, low power analog-to-digital converters, the LTC1412 samples analog input signals at up to 3Mps with 12-bit resolution and accuracy. The LTC1412 operates on a $\pm 5\text{V}$ supply and dissipates just 150mW at full conversion speed. The converter has an analog input range of $\pm 2.5\text{V}$. It is designed for high speed, high resolution signal processing applications, including telecom digital-data transmission applications, wide bandwidth multichannel data acquisition and baseband signal recovery through undersampling. Its simple parallel interface and conversion start signal input make it easy to use in DSP-based designs. The LTC1412 includes an internal reference and conversion clock, microprocessor or microcontroller compatible 12-bit parallel interface and a fully differential input that achieves better than 70dB CMRR over a 0Hz to 3MHz bandwidth. Data is available immediately, without pipeline delay, at the conclusion of a conversion. The LTC1412 is available in a space-efficient 28-pin SO package.

The LTC1412's unique S/H has two very beneficial features that apply when sampling either single-ended or differential signals. The first is a wide, 40MHz full-power input bandwidth. This wide input bandwidth allows the LTC1412 to undersample signals far above the converter's Nyquist frequency and preserve their fidelity. The second is a common mode

rejection of 60dB. When sampling differentially, the common mode rejection is especially useful for suppressing the perturbing effects of common mode noise and ground loops.

The LTC1412 combines excellent dynamic performance with a high speed conversion rate. The signal-to-noise + distortion (SINAD) is 72dB and the total harmonic distortion (THD) is -84dB when sampling a 1.5MHz full-scale input signal at 3Msps.

The LTC1414: Low Power, 2.2Msps 14-Bit ADC

Following on the success of the LTC1419, the world's cleanest 14-bit ADC, LTC has just released the LTC1414. This new high speed, low power analog-to-digital converter samples analog input signals at up to

2.2Msps with 14-bit resolution and accuracy.

The LTC1414 operates on a $\pm 5V$ supply and dissipates just 150mW at full conversion speed. The converter has an analog input range of $\pm 2.5V$. It is designed for high speed, high resolution applications, including telecom digital-data transmission, DSP-based signal processing, wide bandwidth multichannel data acquisition and baseband signal recovery through undersampling. The LTC1414 includes an internal reference, a fast 14-bit parallel interface, and a fully differential input S/H. Conversion results are available without a pipeline delay. The LTC1414 is available in a space-efficient 28-pin narrow SSOP package.

The LTC1414's S/H has a wide, 20MHz full power input bandwidth. This allows the LTC1414 to

undersample signals far above the converter's Nyquist frequency and preserve their fidelity. Its input common mode rejection is better than 70dB over a 0Hz to 3MHz bandwidth. This is especially useful for suppressing the deleterious effects of common mode noise and ground loops when sampling differentially. These features of the LTC1414's unique S/H apply when sampling either single-ended and differential signals.

The LTC1414's high speed conversion rate does not sacrifice dynamic performance. The signal-to-noise + distortion (SINAD) is 80.5dB and the spurious-free dynamic range is 95dB with a 100kHz input signal. This spurious-free dynamic range is an increase of 10dB over 12-bit devices. The SINAD is 78dB at $f_s = 2.2$ Msps and $f_{IN} = 1.1$ MHz. 

Authors can be contacted
at (408) 432-1900

*for
the latest information
on LTC products,
visit
www.linear-tech.com*

For further information on any of the devices mentioned in this issue of *Linear Technology*, use the reader service card or call the LTC literature service number:

1-800-4-LINEAR

Ask for the pertinent data sheets and Application Notes.

DESIGN TOOLS

Applications on Disk

Noise Disk — This IBM-PC (or compatible) program allows the user to calculate circuit noise using LTC op amps, determine the best LTC op amp for a low noise application, display the noise data for LTC op amps, calculate resistor noise and calculate noise using specs for any op amp. Available at no charge

SPICE Macromodel Disk — This IBM-PC (or compatible) high density diskette contains the library of LTC op amp SPICE macromodels. The models can be used with any version of SPICE for general analog circuit simulations. The diskette also contains working circuit examples using the models and a demonstration copy of PSPICE™ by MicroSim. Available at no charge

SwitcherCAD™ — The SwitcherCAD program is a powerful PC software tool that aids in the design and optimization of switching regulators. The program can cut days off the design cycle by selecting topologies, calculating operating points and specifying component values and manufacturer's part numbers. 144 page manual included. \$20.00

SwitcherCAD supports the following parts: LT1070 series: LT1070, LT1071, LT1072, LT1074 and LT1076. LT1082. LT1170 series: LT1170, LT1171, LT1172 and LT1176. It also supports: LT1268, LT1269 and LT1507. LT1270 series: LT1270 and LT1271. LT1371 series: LT1371, LT1372, LT1373, LT1375, LT1376 and LT1377.

Micropower SwitcherCAD™ — The MicropowerSCAD program is a powerful tool for designing DC/DC converters based on Linear Technology's micropower switching regulator ICs. Given basic design parameters, MicropowerSCAD selects a circuit topology and offers you a selection of appropriate Linear Technology switching regulator ICs. MicropowerSCAD also performs circuit simulations to select the other components which surround the DC/DC converter. In the case of a battery supply, MicropowerSCAD can perform a battery life simulation. 44 page manual included. \$20.00

MicropowerSCAD supports the following LTC micropower DC/DC converters: LT1073, LT1107, LT1108, LT1109, LT1109A, LT1110, LT1111, LT1173, LTC1174, LT1300, LT1301 and LT1303.

Technical Books

1990 Linear Databook, Vol I — This 1440 page collection of data sheets covers op amps, voltage regulators, references, comparators, filters, PWMs, data conversion and interface products (bipolar and CMOS), in both commercial and military grades. The catalog features well over 300 devices. \$10.00

1992 Linear Databook, Vol II — This 1248 page supplement to the 1990 Linear Databook is a collection of all products introduced in 1991 and 1992. The catalog contains full data sheets for over 140 devices. The 1992 Linear Databook, Vol II is a companion to the 1990 Linear Databook, which should not be discarded. \$10.00

1994 Linear Databook, Vol III — This 1826 page supplement to the 1990 and 1992 Linear Databooks is a collection of all products introduced since 1992. A total of 152 product data sheets are included with updated selection guides. The 1994 Linear Databook Vol III is a companion to the 1990 and 1992 Linear Databooks, which should not be discarded. \$10.00

1995 Linear Databook, Vol IV — This 1152 page supplement to the 1990, 1992 and 1994 Linear Databooks is a collection of all products introduced since 1994. A total of 80 product data sheets are included with updated selection guides. The 1995 Linear Databook Vol IV is a companion to the 1990, 1992 and 1994 Linear Databooks, which should not be discarded. \$10.00

1996 Linear Databook, Vol V — This 1152 page supplement to the 1990, 1992, 1994 and 1995 Linear Databooks is a collection of all products introduced since 1995. A total of 65 product data sheets are included with updated selection guides. The 1996 Linear Databook Vol V is a companion to the 1990, 1992, 1994 and 1995 Linear Databooks, which should not be discarded. \$10.00

1990 Linear Applications Handbook, Volume I — 928 pages full of application ideas covered in depth by 40 Application Notes and 33 Design Notes. This catalog covers a broad range of "real world" linear circuitry. In addition to detailed, systems-oriented circuits, this handbook contains broad tutorial content together with liberal use of schematics and scope photography. A special feature in this edition includes a 22-page section on SPICE macromodels. \$20.00

1993 Linear Applications Handbook, Volume II — Continues the stream of "real world" linear circuitry initiated by the 1990 Handbook. Similar in scope to the 1990 edition, the new book covers Application Notes 40 through 54 and Design Notes 33 through 69. References and articles from non-LTC publications that we have found useful are also included. \$20.00

1997 Linear Applications Handbook, Volume III — This 976 page handbook maintains the practical outlook and tutorial nature of previous efforts, while broadening topic selection. This new book includes Application Notes 55 through 69 and Design Notes 70 through 144. Subjects include switching regulators, measurement and control circuits, filters, video designs, interface, data converters, power products, battery chargers and CCFL inverters. An extensive subject index references circuits in LTC data sheets, design notes, application notes and *Linear Technology* magazines. \$20.00

Interface Product Handbook — This 424 page handbook features LTC's complete line of line driver and receiver products for RS232, RS485, RS423, RS422, V.35 and AppleTalk® applications. Linear's particular expertise in this area involves low power consumption, high numbers of drivers and receivers in one package, mixed RS232 and RS485 devices, 10kV ESD protection of RS232 devices and surface mount packages. Available at no charge

Power Solutions Brochure — This 84 page collection of circuits contains real-life solutions for common power supply design problems. There are over 88 circuits, including descriptions, graphs and performance specifications. Topics covered include battery chargers, PCMCIA power management, microprocessor power supplies, portable equipment power supplies, micropower DC/DC, step-up and step-down switching regulators, off-line switching regulators, linear regulators and switched capacitor conversion. Available at no charge

High Speed Amplifier Solutions Brochure — This 72 page collection of circuits contains real-life solutions for problems that require high speed amplifiers. There are 82 circuits including descriptions, graphs and performance specifications. Topics covered include basic amplifiers, video-related applications circuits, instrumentation, DAC and photodiode amplifiers, filters, variable gain, oscillators and current sources and other unusual application circuits. Available at no charge

Data Conversion Solutions Brochure — This 52 page collection of data conversion circuits, products and selection guides serves as excellent reference for the data acquisition system designer. Over 60 products are showcased, solving problems in low power, small size and high performance data conversion applications—with performance graphs and specifications. Topics covered include ADCs, DACs, voltage references and analog multiplexers. A complete glossary defines data conversion specifications; a list of selected application and design notes is also included. Available at no charge

Telecommunications Solutions Brochure — This 72 page collection of circuits, new products and selection guides covers a wide variety of products targeted for the telecommunications industry. Circuits solving real life problems are shown for central office switching, cellular phone, base station and other telecom applications. New products introduced include high speed amplifiers, A/D converters, power products, interface transceivers and filters. Reference material includes a telecommunications glossary, serial interface standards, protocol information and a complete list of key application notes and design notes. Available at no charge

Available at no charge

continued on page 40

Acrobat is a trademark of Adobe Systems, Inc. AppleTalk is a registered trademark of Apple Computer, Inc. PSPICE is a trademark of MicroSim Corp.

Information furnished by Linear Technology Corporation is believed to be accurate and reliable. However, Linear Technology makes no representation that the circuits described herein will not infringe on existing patent rights.

CD-ROM

LinearView — LinearView™ CD-ROM version 2.0 is Linear Technology's latest interactive CD-ROM. It allows you to instantly access thousands of pages of product and applications information, covering Linear Technology's complete line of high performance analog products, with easy-to-use search tools.

The LinearView CD-ROM includes the complete product specifications from Linear Technology's Databook library (Volumes I-V) and the complete Applications Handbook collection (Volumes I-III). Our extensive collection of Design Notes and the complete collection of *Linear Technology* magazine are also included.

A powerful search engine built into the LinearView CD-ROM enables you to select parts by various criteria, such as device parameters, keywords or part numbers. All product categories are represented: data conversion, references, amplifiers, power products, filters and interface circuits. Up-to-date versions of Linear Technology's software design tools, SwitcherCAD, Micropower SwitcherCAD, FilterCAD, Noise Disk and Spice Macromodel library, are also included. Everything you need to know about Linear Technology's products and applications is readily accessible via LinearView. LinearView 2.0 runs under Windows® 3.1, Windows 95 and Macintosh® System 7.0 or later.

Available at no charge.

World Wide Web Site

Linear Technology Corporation's customers can now quickly and conveniently find and retrieve the latest technical information covering the Company's products on LTC's new internet web site. Located at www.linear-tech.com, this site allows anyone with internet access and a web browser to search through all of LTC's technical publications, including data sheets, application notes, design notes, *Linear Technology* magazine issues and other LTC publications, to find information on LTC parts and applications circuits. Other areas within the site include help, news and information about Linear Technology and its sales offices.

Other web sites usually require the visitor to download large document files to see if they contain the desired information. This is cumbersome and inconvenient. To save you time and ensure that you receive the correct information the first time, the first page of each data sheet, application note and *Linear Technology* magazine is recreated in a fast, download-friendly format. This allows you to determine whether the document is what you need, before downloading the entire file.

The site is searchable by criteria such as part numbers, functions, topics and applications. The search is performed on a user-defined combination of data sheets, application notes, design notes and *Linear Technology* magazine articles. Any data sheet, application note, design note or magazine article can be downloaded or faxed back. (Files are downloaded in Adobe Acrobat™ PDF format; you will need a copy of Acrobat Reader to view or print them. The site includes a link from which you can download this program.)

Acrobat is a trademark of Adobe Systems, Inc.; Windows is a registered trademark of Microsoft Corp.; Macintosh is a registered trademark of Apple Computer, Inc.

World Headquarters

Linear Technology Corporation
1630 McCarthy Boulevard
Milpitas, CA 95035-7417
Phone: (408) 432-1900
FAX: (408) 434-0507

U.S. Area Sales Offices

NORTHEAST REGION

Linear Technology Corporation
3220 Tillman Drive, Suite 120
Bensalem, PA 19020
Phone: (215) 638-9667
FAX: (215) 638-9764

Linear Technology Corporation

266 Lowell St., Suite B-8
Wilmington, MA 01887
Phone: (508) 658-3881
FAX: (508) 658-2701

NORTHWEST REGION

Linear Technology Corporation
1900 McCarthy Blvd., Suite 205
Milpitas, CA 95035
Phone: (408) 428-2050
FAX: (408) 432-6331

SOUTHEAST REGION

Linear Technology Corporation
17000 Dallas Parkway
Suite 219
Dallas, TX 75248
Phone: (214) 733-3071
FAX: (214) 380-5138

Linear Technology Corporation

5510 Six Forks Road
Suite 102
Raleigh, NC 27609
Phone: (919) 870-5106
FAX: (919) 870-8831

CENTRAL REGION

Linear Technology Corporation
Chesapeake Square
229 Mitchell Court, Suite A-25
Addison, IL 60101
Phone: (708) 620-6910
FAX: (708) 620-6977

SOUTHWEST REGION

Linear Technology Corporation
21243 Ventura Blvd.
Suite 227
Woodland Hills, CA 91364
Phone: (818) 703-0835
FAX: (818) 703-0517

Linear Technology Corporation

15375 Barranca Parkway
Suite A-211
Irvine, CA 92718
Phone: (714) 453-4650
FAX: (714) 453-4765

International Sales Offices

FRANCE

Linear Technology S.A.R.L.
Immeuble "Le Quartz"
58 Chemin de la Justice
92290 Chatenay Malabry
France
Phone: 33-1-41079555
FAX: 33-1-46314613

GERMANY

Linear Technology GmbH
Oskar-Messter-Str. 24
85737 Ismaning
Germany
Phone: 49-89-962455-0
FAX: 49-89-963147

JAPAN

Linear Technology KK
5F NAO Bldg.
1-14 Shin-Ogawa-cho Shinjuku-ku
Tokyo, 162
Japan
Phone: 81-3-3267-7891
FAX: 81-3-3267-8510

KOREA

Linear Technology Korea Co., Ltd
Namsong Building, #403
Itaewon-Dong 260-199
Yongsan-Ku, Seoul 140-200
Korea
Phone: 82-2-792-1617
FAX: 82-2-792-1619

SINGAPORE

Linear Technology Pte. Ltd.
507 Yishun Industrial Park A
Singapore 2776
Phone: 65-753-2692
FAX: 65-754-4113

SWEDEN

Linear Technology AB
Sollentunavägen 63
S-191 40 Sollentuna
Sweden
Phone: 46-8-623-1600
FAX: 46-8-623-1650

TAIWAN

Linear Technology Corporation
Rm. 602, No. 46, Sec. 2
Chung Shan N. Rd.
Taipei, Taiwan, R.O.C.
Phone: 886-2-521-7575
FAX: 886-2-562-2285

UNITED KINGDOM

Linear Technology (UK) Ltd.
The Coliseum, Riverside Way
Camberley, Surrey GU15 3YL
United Kingdom
Phone: 44-1276-677676
FAX: 44-1276-64851

LINEAR TECHNOLOGY CORPORATION

1630 McCarthy Boulevard
Milpitas, CA 95035-7417
(408) 432-1900 FAX (408) 434-0507
www.linear-tech.com

For Literature Only: 1-800-4-LINEAR

