

Tiny Charger Fast Charges Up to 1A While System is Operating

Often it is desirable to operate a lap top, video camera or portable instrument while charging their batteries. Previously this required a more costly AC adapter, capable of supplying sufficient current for both tasks simultaneously. The circuit below uses a standard, inexpensive AC adapter yet allows the battery to be charged at its maximum possible rate.* It monitors the AC adapter current and, if needed, reduces the charge current to avoid overloading the adapter. The PC board area required by the LT1510/LT1620 pair is less than 0.25 square inches.

The LT1510's 2A saturating switch allow up to 1.5A of charging current, provided that good thermal layout practices are observed. The current limit

function for the AC adapter is performed by the LT1620 rail-to-rail current sense amplifier. The LT1121-5 linear regulator provides power to the LT1620 and the LT1510's boost pin. (If an existing 5V @ 20mA power source is available, the LT1121-5 is not needed).

The LT1620 performs input current limiting by monitoring the system input current and reducing the charging current in order to maintain the pre-determined current across the input current sense resistor, R₆.

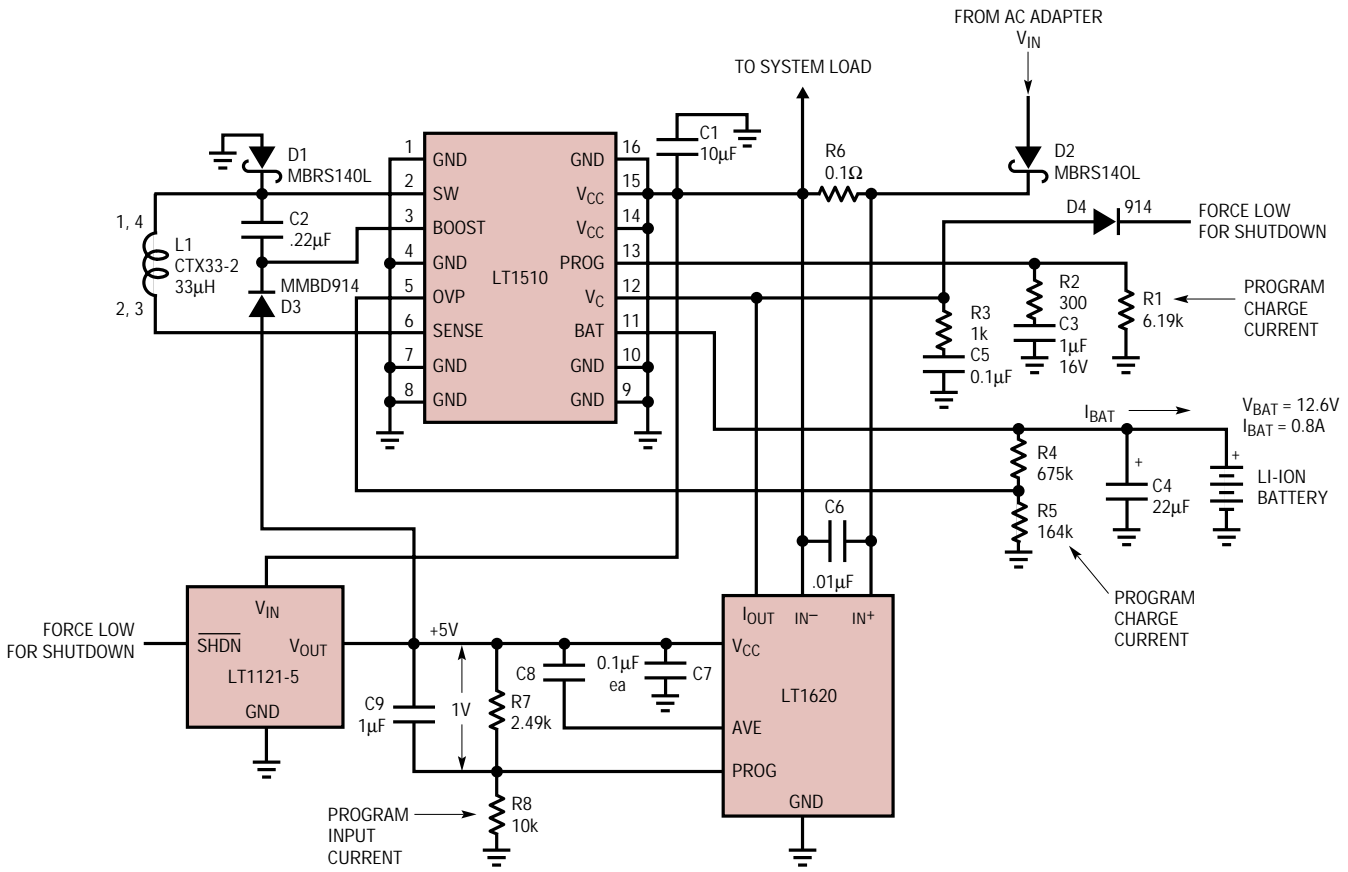

PROGRAM INPUT CURRENT LIMIT (SEE TEXT)
FOR VALUES SHOWN, INPUT CURRENT LIMIT = 1A

PROGRAM CHARGE VOLTAGE
 $R_4 = R_5 \left(\frac{V_{OUT}}{V_{REF}} - 1 \right)$
 $V_{REF} = 2.465V$

PROGRAM CHARGE CURRENT
 $R_1 = \frac{(2000)(2.465)}{I_{BAT}}$

* US Patent # 5,723,970

Source: LTC Applications Dept.
www.linear-tech.com/chargers.html



- Battery Chargers
- Desktop PC Power
- Notebook PC Power
- Portable Equip. Power
- Distributed Power
- Isolated Power
- Off-Line Power Supplies
- Power Management
- Appendices