

manual

**Polytec**  
**Compact Laser Vibrometer**  
**CLV-1000 / CLV-700**

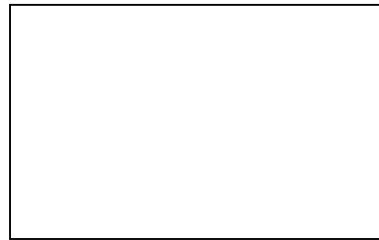

Controller identification



Identification measuring head

Polytec reserves the right to discontinue the products described in this manual at any time and without prior notice.

We reserve all rights to the product and the accompanying functional descriptions. Publishers and

Author: none      Responsibility for      Errors, omissions, or resulting loss of information.

## **Warranty and service**

The warranty for this device complies with the provisions in our general terms and conditions of sale and delivery in their currently valid version.

The condition is that the device is used as intended, as described in this manual.

The warranty does not cover damage caused by improper use, external mechanical influences, or failure to comply with operating conditions. The warranty is also void in the event of unauthorized tampering or modification of the device.

The original packaging must be used for all returns. Otherwise, we reserve the right to inspect the devices for transport damage. Please mark the shipment as fragile and include an explanation of the reason for the return as well as a detailed description of the defect.

Troubleshooting advice can be found in section 4.6.

# Table of contents

<b>1 Safety instructions</b>	<b>1-1</b>
1.1 Laser Safety .....	1-1
1.2 Laser warning signs .....	1-2
1.2.1 CLV with external laser module .....	1-3
1.2.2 CLV with internal laser module.....	1-3
1.3 Electrical Safety.....	1-3
<b>2 Introduction to the CLV system</b>	<b>2-1</b>
2.1 System overview .....	2-1
2.2 Area of application.....	2-1
2.3 Measuring principle.....	2-2
2.4 Module Overview .....	2-2
<b>3. Detailed device description</b>	<b>3-1</b>
3.1 Measuring Head.....	3-1
3.1.1 Fixed Focus Variant .....	3-1
3.1.2 Variable Focus Variant.....	3-2
3.1.3 Working Distances for the Variable Focus Measuring Head.....	3-2
3.2 Laser modules.....	3-3
3.2.1 External laser module CLV-800 .....	3-3
3.2.2 Internal laser module CLV-M000.L .....	3-4
3.3 Controller.....	3-5
3.3.1 Front Panel .....	3-5
3.3.2 Rear Panel .....	3-6
3.4 Input Module CLV-M100 and CLV-M200 .....	3-7
3.5 Decoder Modules .....	3-8
3.5.1 CLV-M010 .....	3-9
3.5.2 CLV-M020 .....	3-10
3.5.3 CLV-M030 .....	3-11
3.6 Output Module.....	3-12
3.6.1 CLV-M001 .....	3-12
3.6.2 CLV-M002 .....	3-13
3.6.3 CLV-M003 .....	3-14
3.6.4 Use of the Filters .....	3-15
<b>4 Operating Instructions</b>	<b>4-1</b>
4.1 Operating and Maintenance Instructions.....	4-1
4.2 Unpacking and Inspection .....	4-2

4.3 Functional test .....	4-3
4.3.1 CLV with external laser module .....	4-3
4.3.2 CLV with internal laser module.....	4-4
4.4 Installation .....	4-5
4.4.1 CLV with external laser module .....	4-5
4.4.2 CLV with internal laser module.....	4-5
4.5 Operating the CLV.....	4-6
4.6 Troubleshooting.....	4-7
4.6.1 General Tests.....	4-7
4.6.2 Tests with External Laser Module.....	4-7
4.6.3 Tests with Internal Laser Module.....	4-8
4.6.4 Tests on the Controller.....	4-8
4.7 Module Replacement .....	4-9
4.8 Selection of new module sets.....	4-9

## 5 Technical Specifications

**5-1**

5.1 Controller CLV-1000.....	5-1
5.1.1 General Data.....	5-1
5.1.2 Input Module.....	5-2
5.1.3 Decoder Module.....	5-2
5.1.4 Output Module.....	5-3
5.2 Measuring Head CLV-700 .....	5-4
5.3 External laser module CLV-800 .....	5-6

## 1 Safety instructions

### 1.1 Laser safety

The CLV is equipped with a helium-neon laser as its light source. The properties of laser light differ from those of conventional light sources. Due to its low divergence, laser radiation is generally very intense. The entry of the direct or reflected beam into the eye must be prevented at all costs. The following precautions have been taken for this purpose:

- Polytec devices generally comply with the standards **EN 60825-1** (DIN VDE 0837) or FDA 1040.10 (US).
- The optical power output is less than 1 mW during normal operation.  
The CLV therefore corresponds to **laser safety class II** and is generally very safe. Even the focused laser beam does not pose a risk to the skin.
- The measuring head is equipped with a **mechanical beam shutter** to protect the  
To block the laser beam if necessary, without switching off the CLV.
- The **emission indicator** on the measuring head signals the laser's activity and thus the  
Potential hazard from escaping laser beams.
- The laser is switched on using a **key switch** on the controller. The key  
It can only be pulled out when the controller is switched off.
- For proper use, the housing of the measuring head and the laser module **does not need to be opened** .  
Opening the housing will void the warranty.

**Please observe** the following **precautions** when using the CLV:

- Avoid looking directly into the laser beam with the naked eye and with  
Use mirrors or optical instruments!
- Use the beam shutter to block the laser beam if necessary!
- To position the measuring head, first switch the beam shutter to the OFF position. Only after the  
measuring head is roughly aligned and securely mounted should the laser beam be released for  
fine positioning.
- Do not use reflective tools, watches, etc. when in the path of the beam.  
Lasers are working!

## 1.2 Laser warning signs

The laser warning signs for the CLV are shown in Figure 1.1.



Figure 1.1: Laser warning signs on the CLV

The laser warning triangle is mounted on the top of the measuring head as shown in Figure 1.2.

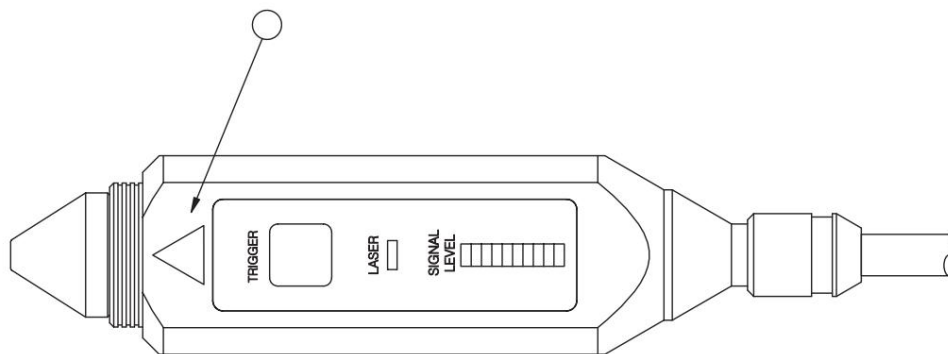

Figure 1.2: Position of the laser warning triangle on the measuring head

### 1.2.1 CLV with external laser module

On the CLV with an external laser module, the laser warning signs are attached to the top of the laser module, as shown in Figure 1.3.

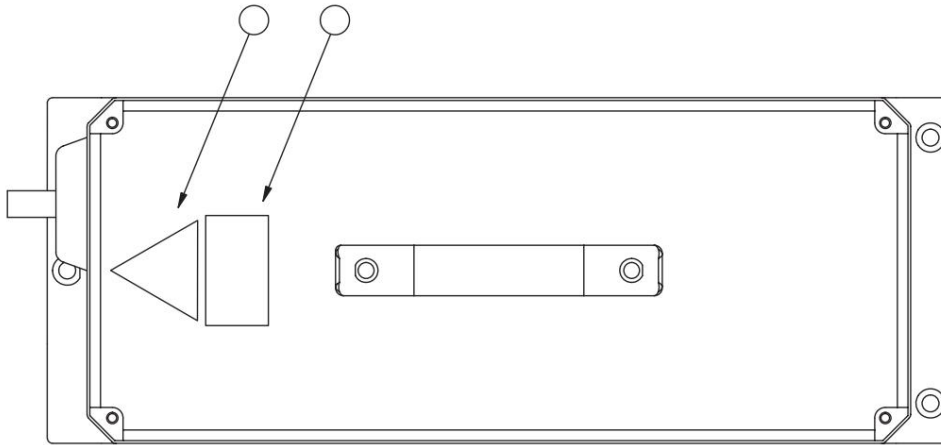

Figure 1.3: Location of the laser warning signs on the external laser module

### 1.2.2 CLV with internal laser module

For the CLV with an internal laser module, the laser warning label is included with the measuring head, as its size makes it impossible to attach the label there. Attach this label in a clearly visible location near the mounted measuring head.

## 1.3 Electrical Safety

The CLV complies with electrical protection class I. Electric shocks are prevented by the closed, grounded metal housing. Observe the following precautions when using the CLV:

- The CLV may only be connected to AC power networks 50/60 Hz with an earthed protective conductor via a three-pole power cable, where the nominal voltage does not exceed 240 V.
- Defective mains fuses may only be replaced by 2.0 A / slow-blow mains fuses.
- The CLV must not be operated with the housing open. Always unplug the power cord before removing any housing parts.
- Air inlets and outlets must always be kept clear to ensure adequate cooling.  
If the fan failure is noticed, the CLV should be switched off immediately.

## 2 Introduction to the CLV system

### 2.1 System Overview

The Polytec Compact Laser Vibrometer (CLV) measures surface vibration velocities without contact. The CLV consists of the **controller** and the **measuring head**. The **laser** is available as an add-on or integrated into the controller.

The CLV is flexibly configured by the user for a specific application. The controller is built from **modules** that determine the CLV's properties. The measuring head can be implemented in two different **versions** . An example system configuration is shown in Figure 2.1.

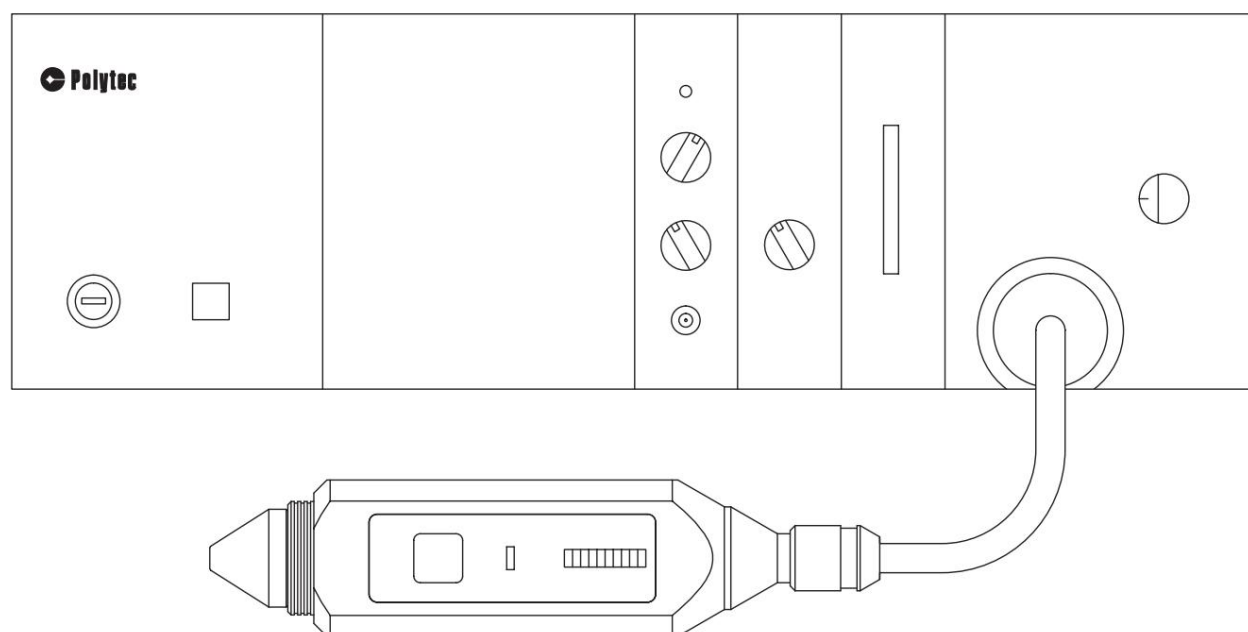

Figure 2.1: Example system configuration of the CLV

The controller is mounted in a 19" industrial enclosure and includes the power supply as standard. The controller also contains one **input module** , one **decoder module** , and one **output module** . Various **additional modules** can also be installed. A module overview is provided in section 2.4.

### 2.2 Area of application

The CLV is a high-performance optoelectronic device for the non-contact measurement of vibration velocities. The wide range of applications encompassed by these devices cannot be covered by a single instrument. However, the variety of modules available for the CLV makes it possible to solve a large proportion of these challenges.

By selecting the optimal modules, a specific measurement task can be handled with maximum resolution and linearity. Since the modules can be replaced by the user, troubleshooting is accelerated, especially for online measurements in industrial applications. At the same time, this flexible modular concept allows the CLV to be reconfigured for a new application as needed.

### 2.3 Measurement principle

The CLV measures vibration velocities based on laser interferometry.

A beam from a helium-neon laser is directed at the vibrating measuring surface and from there backscattered. In this process, the measuring beam undergoes a small frequency change, which is described as The Doppler frequency is denoted as  $f_D$ . The Doppler frequency is a function of the velocity component in the direction of the laser beam accordingly

$$f_D = 2 \frac{|\dot{y}|}{\lambda}$$

A beat frequency is created by superimposing the measuring beam with an internal reference beam, whose frequency is equal to the Doppler frequency. However, this is independent of the sign.

the speed. The direction is determined by introducing an additional, fixed

The frequency shift  $f_B$  into the interferometer is determined, to which the Doppler frequency corresponds.

The sign is precisely measured when added. The resulting frequency shift at the photoreceiver is  $\dot{y}f$ . does this give you

$$\dot{y} f_B = \frac{v}{\lambda}$$

The signal converted by the photoreceiver is processed in the controller using FM demodulation. decoded. This generates a voltage proportional to the current state.

The speed of the measuring surface is measured. This analog voltage signal can be displayed on the front panel.

The controller's data is tapped and processed externally.

### 2.4 Module Overview

The following table summarizes all modules according to their module type. Chapter 3 provides a detailed description of each module.

Table 2.1: Overview of the CLV modules

Module type	function	Designation	Width / slots <sup>1</sup>	position <sup>2</sup>
Input Module	Processing the HF-input signal	CLV-M100 CLV-M200	19	
Decoder module	Decoding the Speed information	CLV-M010 CLV-M020 CLV-M030	1	4, 5, 6, 7 or 8
Output Module	Processing and output of the Measurement signal	CLV-M001 CLV-M002 CLV-M003	1	4, 5, 6, 7 or 8
Supplementary module	for further processing of the Measurement signal, in preparation	CLV-M000.1...5	1, 2 or 3	4, 5, 6, 7 or 8
	Battery power supply instead of network operation	CLV-M000.6	3	1 to 3
	Internal laser module	CLV-M000.L	3	10 to 12
Blind front panel	Closure of free slots in the controller	CLV-B1 CLV-B2 CLV-B3	1 2 3	as needed

<sup>1</sup>

The controller housing provides a total of 12 slots of 7 HP (approx. 35 mm) each.

<sup>2</sup>

The position is counted from left to right when looking at the front panel, see Figure 3.5.

## 3. Detailed device description

### 3.1 Measuring head

The measuring head, together with the laser module (external or internal), forms the interferometer and is permanently connected to the laser module via a cable.

In the **fixed focus variant (ff)**, the working distance is  $316 \text{ mm} \pm 50 \text{ mm}$  from the shoulder of the measuring head (see Figure 5.1) and cannot be changed.

With the **variable focus (vf)** version, the working distance can be changed by moving the front lens. However, please note the information on optimal working distances in section 3.1.3.

#### 3.1.1 Variant with fixed focus

The fixed focus measuring head is shown with the operating elements in Figure 3.1.

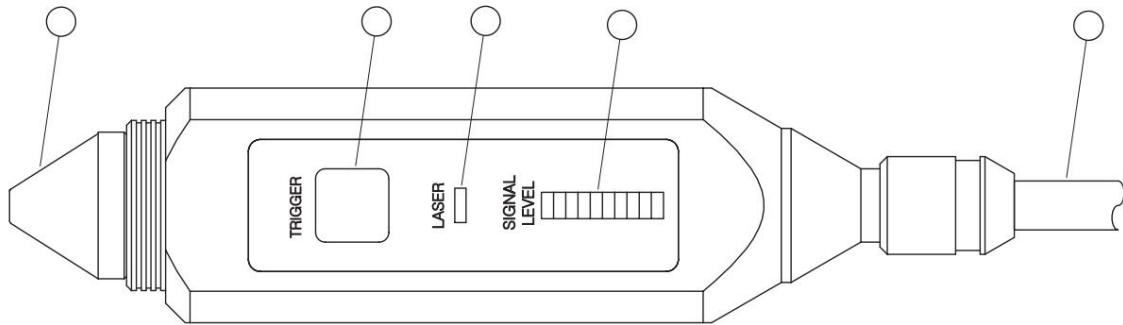

Figure 3.1: Top view of the measuring head, fixed focus variant

**Protective cap** for the front optics: To

clean the front optics, you can unscrew the protective cap.

**TRIGGER** - Button for manually triggered signal acquisition. When the

button is pressed, a falling signal edge  $+5 \text{ V} \rightarrow 0 \text{ V}$  is generated at the BNC TRIGGER connector on the back panel of the controller.

**LASER** - LED

The LED lights up when the laser is switched on, i.e., even when the beam shutter is closed.

**Signal level indicator:**

The length of the bar is a measure of the light scattered back from the object being measured.

**Connection cable** to the laser module: The

protective sheath contains the fiber optic cable as well as the electrical connection cables from the laser module.

### 3.1.2 Variant with variable focus

The measuring head with variable focus is shown with the operating elements in Figure 3.2.

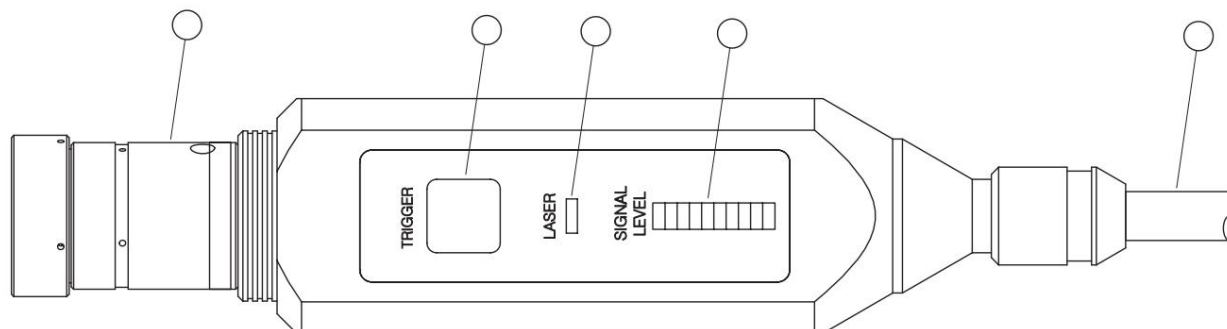

Figure 3.2: Top view of the measuring head, variant with variable focus

#### **Distance ring** for focusing

If you look in the direction of the emitting beam, focus on

Infinity: turn left

Close range: turn to the right

**TRIGGER** - Button for manually triggered signal acquisition. When the

button is pressed, a falling signal edge +5 V  $\rightarrow$  0 V is generated at the BNC TRIGGER connector on the back panel of the controller.

**LASER** - LED

The LED lights up when the laser is switched on, i.e., even when the beam shutter is closed.

#### **Signal level indicator:**

The length of the bar is a measure of the light scattered back from the object being measured.

**Connection cable** to the laser module: The

protective sheath contains the fiber optic cable as well as the electrical connection cables from the laser module.

### 3.1.3 Working distances for the variable focus measuring head

A helium-neon laser serves as the light source for the CLV. This is a multimode laser in which a maximum of two modes can be generated. The interference of these two modes causes the intensity of the resulting optical signal to vary periodically with the working distance. The intensity reaches its maximum, i.e., a coherence maximum is reached, when the optical path difference is an even multiple of the laser resonator length. Since the optical path length is equal to twice the working distance (the beam travels back and forth), the coherence maximum is reached once per resonator length (205 mm).

In the fixed focus variant, the working distance corresponds to a coherence maximum.

The working distance is 316 mm  $\pm$  50 mm from the shoulder of the measuring head.

For the variable focus version, the optimal working distances, measured from the shoulder of the measuring head, are 316 mm, 521 mm, 726 mm, etc.

## 3.2 Laser modules

The laser module, together with the measuring head, forms the interferometer and is permanently connected to the measuring head via a cable. The choice between an internal and external laser module is primarily determined by the desired system installation.

Since the **internal** laser module is part of the controller, the measuring head and controller cannot be separated. The length of the connecting cable is limited to a maximum of 10 meters (standard 3 meters).

The **external** laser module can be installed close to the measuring head, while the controller can be located up to 30 meters away (standard 5 meters). The connecting cable between the controller and the external laser module is detachable.

### 3.2.1 External laser module CLV-800

The rear of the external laser module is shown with the controls in Figure 3.3.

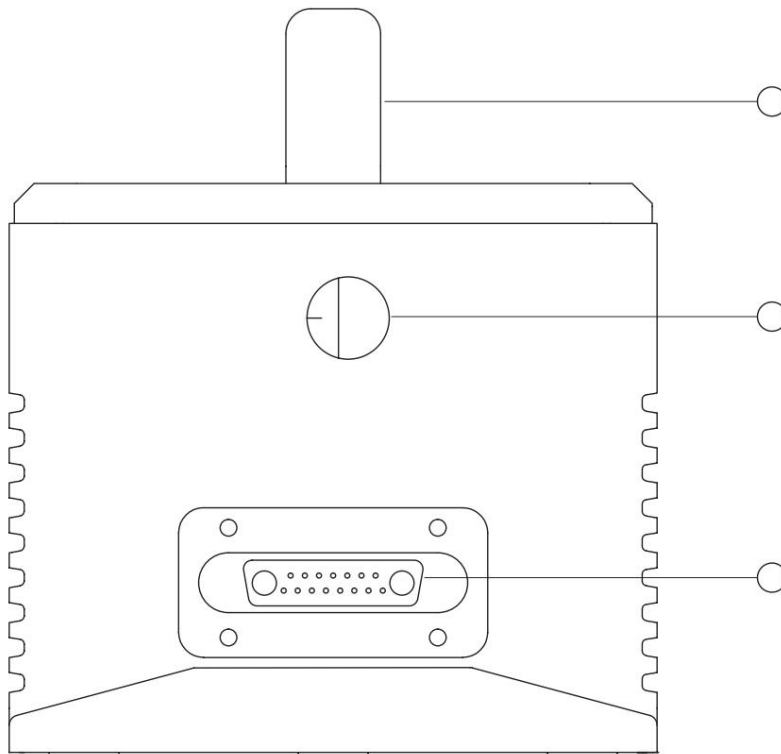

Figure 3.3: Rear view of the external laser module

#### **Carrying handle**

#### mechanical **beam shutter**

In the OFF position, the laser beam is blocked.

#### **Controller** - Connection

Connector for the connecting cable to the controller

### 3.2.2 Internal laser module CLV-M000.L

Please note that the internal laser module is not a replaceable module and may only be replaced by trained personnel.

The partial front panel of the internal laser module is shown with the operating elements in Figure 3.4.

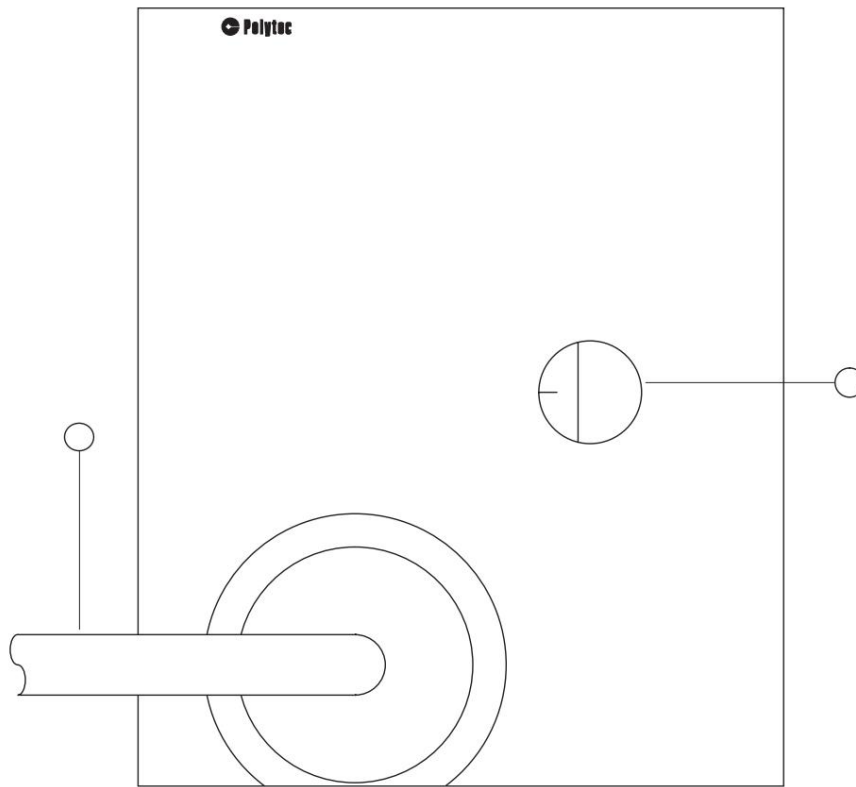

Figure 3.4: Partial front panel of the internal laser module CLV-M000.L

**Connection cable** to the measuring head:

The protective sheath contains the fiber optic cable as well as the electrical connection cables to the measuring head.

**mechanical beam shutter**

In the OFF position, the laser beam is blocked.

## 3.3 Controller

### 3.3.1 Front panel

The front panel of the controller is shown in Figure 3.5. Instead of the partial front panels of the variable modules, only the module types that can be installed in the respective slot are indicated.

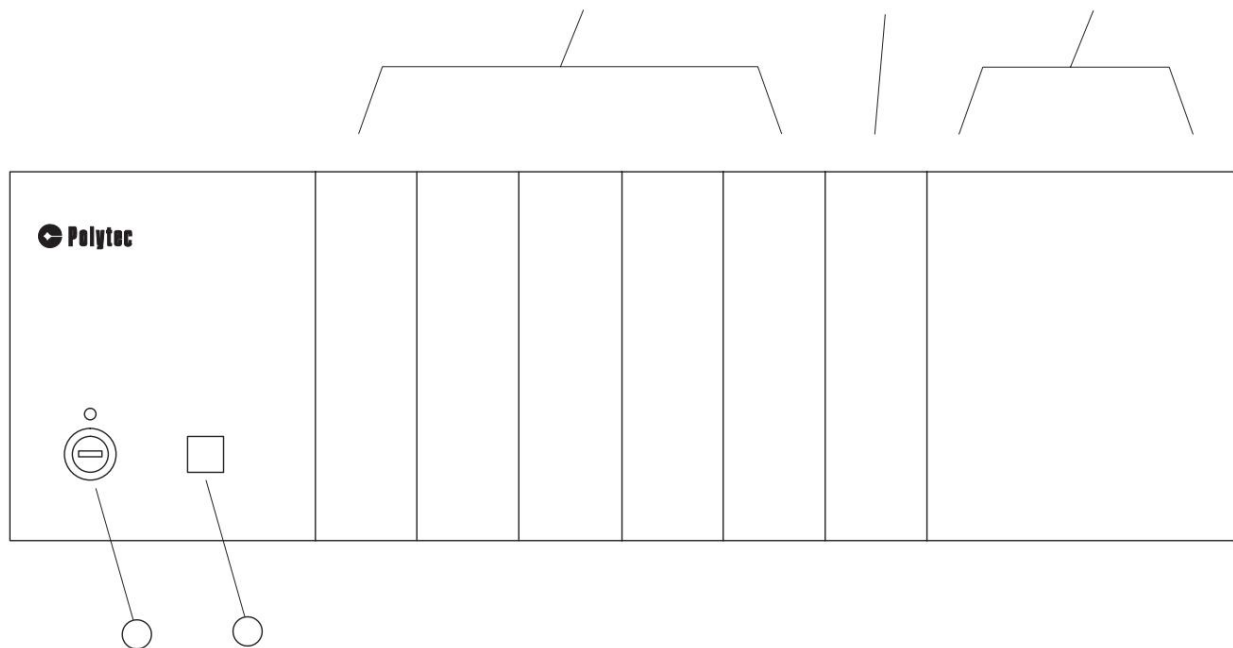

Figure 3.5: Schematic front view of the controller

#### power switch

The key switch disconnects the controller from the mains power supply on all poles (position O) and is used for shutdown in case of danger. The key can only be removed in position O.

#### **Warning!**

Always connect the cable to the external laser module **before** switching on the controller!

**POWER** indicator: The

illuminated lamp indicates that the controller is ready for operation.

### 3.3.2 Backplate

The controller's backplate is shown in Figure 3.6. It is independent of the modules that are installed.

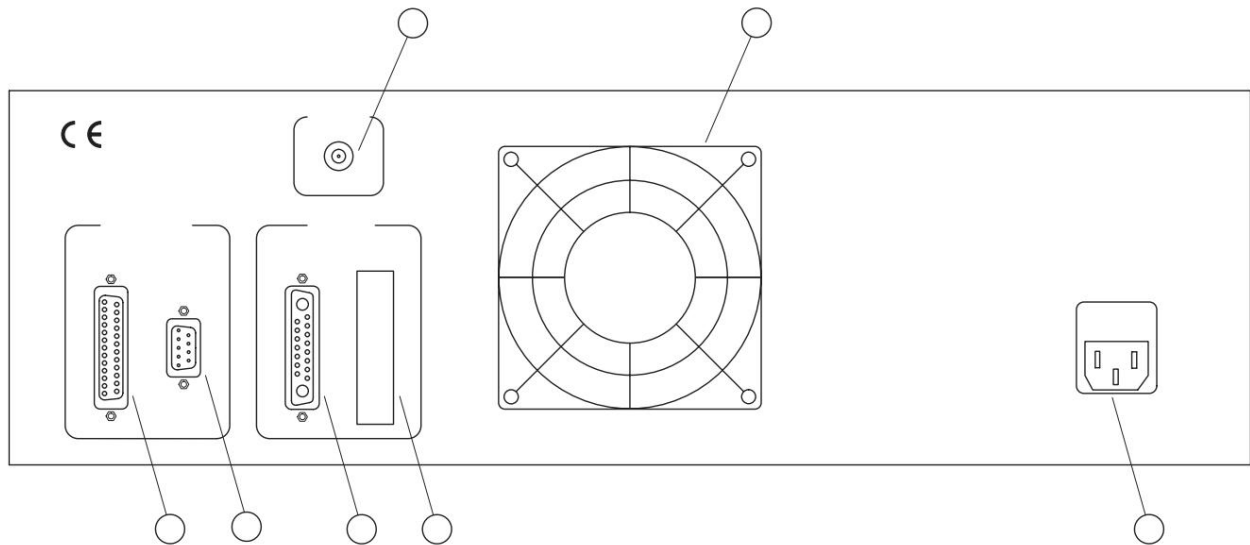

Figure 3.6: Controller backplate

#### **TRIGGER** - Output (BNC)

A falling signal edge +5 V  $\rightarrow$  0 V is generated at this output when the TRIGGER button on the measuring head is pressed.

#### **fan**

##### **Warning!**

This opening must be kept clear at all times to ensure adequate cooling. The distance to the wall should be at least 50 mm.

#### **network connection combination**

IEC C14 power outlet with built-in fuses

##### **Caution !**

Always unplug the power cord before opening the casing!

#### **SENSOR B** - Connection

Connector for the connecting cable to a second external laser module (option).

#### **SENSOR A** - Connection

Connector for the connecting cable to the external laser module. This connector is not installed with an internal laser module.

#### **RS-232** interface

9-pin D-sub connector for the serial interface (option), in Preparation

#### **CONTROL** interface

The 25-pin D-sub connector provides various input and output signals for integrating the CLV into automatic measurement systems.

### 3.4 Input modules CLV-M100 and CLV-M200

The input module processes the RF signal coming from the measuring head. This includes the following functions:

- Amplification and band limiting
  - Signal conditioning using tracking filters
  - Conversion of the RF signal to a suitable intermediate frequency for the subsequent decoder module
- The decoder module has been adapted.

Additionally, the input module measures the level of the optical signal and displays it on the front panel as a bar graph.

The partial front panel is compatible with all input modules except for the type designation (CLV-M100 or CLV-M100). CLV-M200). It is shown with the controls in Figure 3.7.

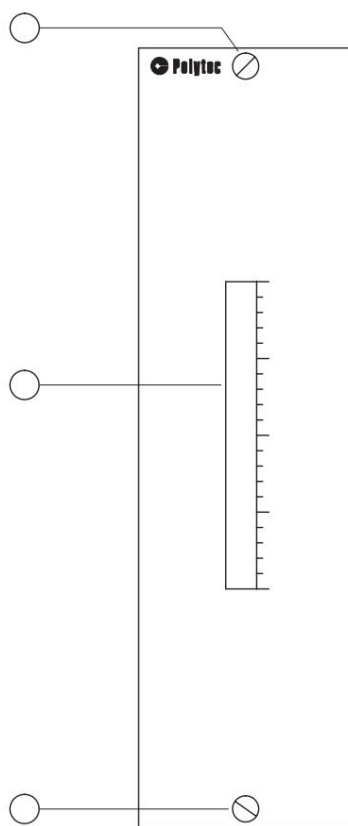

**Knurled screws** for attaching the module. Module replacement is described in section 4.7.

**Signal level indicator:**

The length of the bar is a measure of the light scattered back from the object being measured.

Figure 3.7: Partial front panel of the input module

The tracking filter in the input module can be switched internally and thus adapted to the respective application. The available settings are NARROW (narrow), WIDE (wide), and OFF. In the NARROW setting, signal conditioning by the tracking filter is most effective, but the maximum detectable acceleration is lowest. The optimal setting is determined by the application and the installed decoder module (see sections 3.5.1 to 3.5.3).

To switch the tracking filter, remove the input module from the controller as described in section 4.7. Figure 3.8 shows an excerpt from the mainboard assembly diagram.

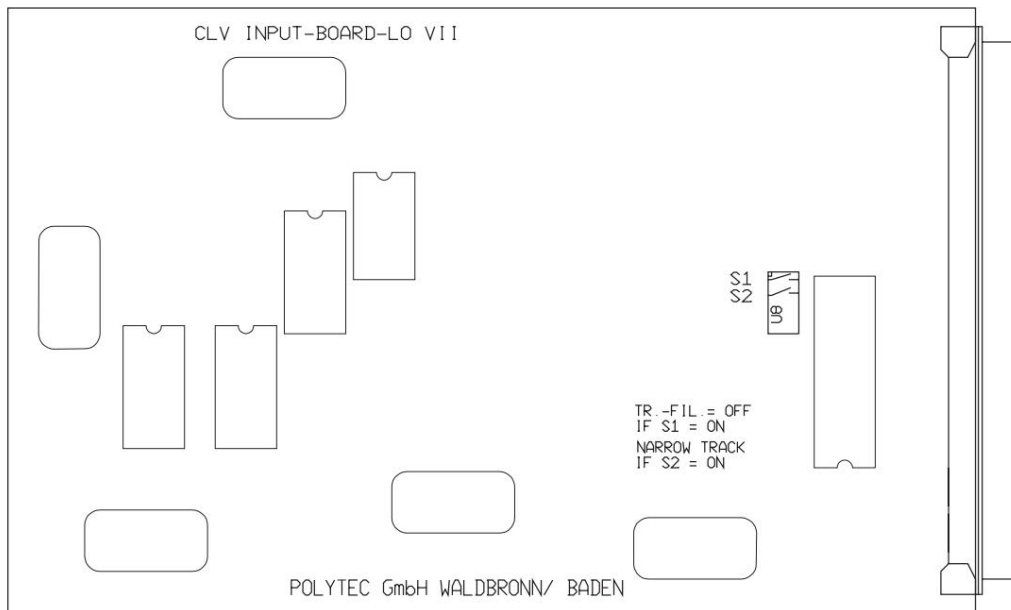

Figure 3.8: Assembly plan of the main board of the input module (excerpt)

Set the tracking filter using switches S1 and S2, as shown in Table 3.1.

Tracking filter settings	S1	S2
NARROW	OFF	ON
WIDE	OFF	OFF
OFF	ON	any

Table 3.1: Tracking filter settings on the mainboard of the input module

### 3.5 Decoder Module

The decoder module decodes the measurement signal using FM demodulation. This process... an alternating voltage is generated that is proportional to the instantaneous speed of the  
The object being measured is.

For **industrial applications in the acoustic and near-ultrasound range**, the Decoder modules **CLV-M010** and **CLV-M020** were designed. They each provide two measuring ranges. available at a cutoff frequency of **50 kHz**. The selection is based on the  
The expected size of the measurement signal was met.

For **special applications** at high frequencies, the **CLV-M030** decoder module with three  
Designed for measuring ranges and a cutoff frequency of **250 kHz**.

The following sections describe all decoder modules. Only the following is relevant for you:  
The relevant section refers to your actually installed decoder module.

### 3.5.1 CLV-M010

A **CLV-M100** input module must be installed for this decoder module to function correctly. With the CLV-M200 input module, only the 5 mms-1/V measuring range is usable.

The partial front panel is shown with the controls in Figure 3.9.

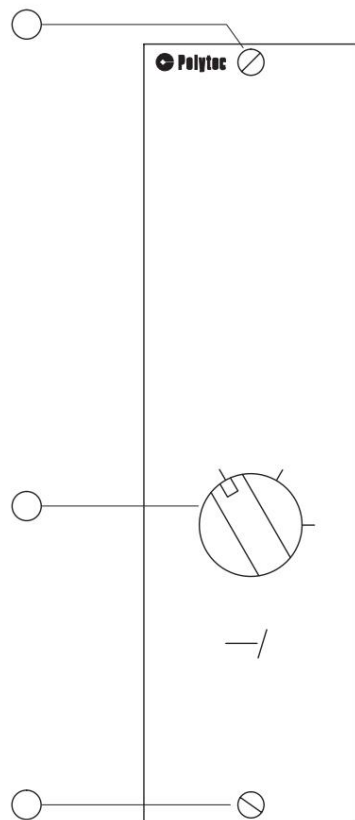

**Knurled screws** for attaching the module. Module replacement is described in section 4.7.

Rotary switch for the **measuring range**

In position R (remote), the measuring range is set remotely (option).

Figure 3.9: Partial front panel of the CLV-M010 decoder module

The decoder module is suitable for the smallest vibration amplitudes in the acoustic range.

The **1 mm V** measuring range offers the highest sensitivity and resolution, for example to test for inherent noises on motors and mechanisms at frequencies up to 20 kHz.

The **5 mmV measurement range** is also designed for this application but features increased output headroom. This range is particularly suitable for small signals superimposed with larger ambient vibrations. Due to its very high **signal** -to-noise ratio, very small signals can still be resolved despite the lower nominal sensitivity. When used with a high-pass filter, such as the CLV-M002 output module, low-frequency ambient vibrations can be suppressed, thus preventing overload. The maximum frequency for this measurement range is 50 kHz.

Since the decoder module has a relatively low acceleration limit of 1,600 g, the tracking filter in the input module can be set to **NARROW**, where it works best.

Therefore, check this setting as described in section 3.4 if you are retrofitting this decoder module.

### 3.5.2 CLV-M020

A **CLV-M200** input module must be installed for this decoder module to function correctly. With the CLV-M100 input module, only the 5 mms-1/V measuring range is usable.

The partial front panel is shown with the controls in Figure 3.10.

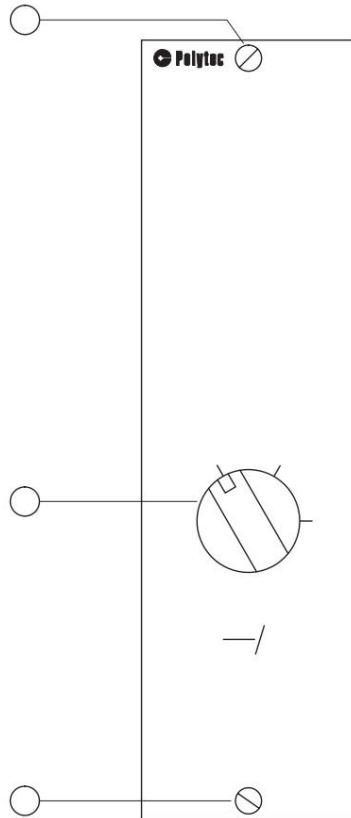

**Knurled screws** for attaching the module. Module replacement is described in section 4.7.

Rotary switch for the **measuring range**

In position R (remote), the measuring range is set remotely (option).

Figure 3.10: Partial front panel of the CLV-M020 decoder module

The decoder module is suitable for medium oscillation amplitudes at frequencies up to 50 kHz.

The **measuring range is 5 mm/s**. With its very high signal-to-noise ratio, **V** also allows for very to detect small vibration amplitudes.

The **25 mm V** measuring range, with its peak speed of 300 mm/s, covers almost all measurement tasks in the acoustic range and offers sufficient control reserve in the event of strong ambient vibrations.

To fully utilize the maximum acceleration of 8,000 g in the 25 mms<sup>2</sup>/V measurement range, the tracking filter in the input module must be set to WIDE. However, if the acceleration remains consistently below approximately 350 g due to low frequencies, noise can be better suppressed with the NARROW setting. Setting the tracking filter in the input module is described in section 3.4. In the lower measurement range of 5 mms<sup>2</sup>/V, the tracking filter automatically switches to the optimal NARROW operating mode unless manually deactivated.

### 3.5.3 CLV-M030

A **CLV-M200** input module must be installed for this decoder module to function correctly . With the CLV-M100 input module, only the 5 mms-1/V measuring range is usable.

The partial front panel is shown with the controls in Figure 3.11.

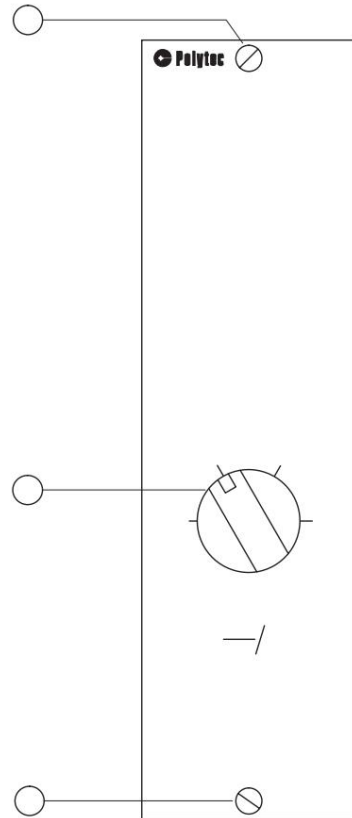

**Knurled screws** for attaching the module. Module replacement is described in section 4.7.

Rotary switch for the **measuring range**

In position R (remote), the measuring range is set remotely (option).

Figure 3.11: Partial front panel of the CLV-M020 decoder module

The decoder module is suitable for medium and large vibration amplitudes in the acoustic and near-ultrasound range.

The **measuring range is 5 mm/s/V**, with its very high signal-to-noise ratio, also allows for very to detect small vibration amplitudes.

The **25 mm V** measuring range, with its peak speed of 250 mm/s, covers almost all measurement tasks in the acoustic range and offers sufficient control reserve in the event of strong ambient vibrations.

The **measuring range is 125 mm/s/V** allows with its top speed of 1.25 m/s, To detect high-energy vibrations, e.g., using acoustic and ultrasonic transducers.

## 3.6 Output Module

In the output module, the measurement signal is scaled, filtered, and output via a BNC connector.

The following sections describe all decoder modules. Only the section relating to your actually installed decoder module is relevant to you.

### 3.6.1 CLV-M001

The partial front panel is shown with the controls in Figure 3.12.

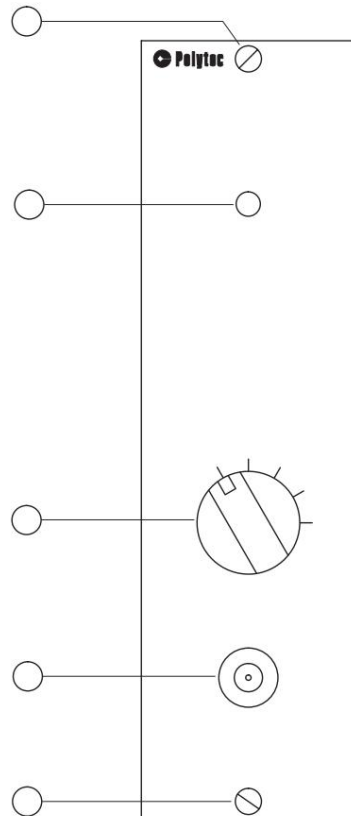

**Knurled screws** for attaching the module. Module replacement is described in section 4.7.

**Overload indicator:** The LED lights up when the output voltage exceeds the range limit.

Rotary switch for the **low-pass filter** : In the OFF position, the low-pass filter is switched off. In the R (remote) position, the low-pass filter is remotely controlled (optional).

**Analog voltage output (BNC)** for the measurement signal. The alternating voltage is proportional to the instantaneous speed of the object being measured.

Figure 3.12: Partial front panel of the output module CLV-M001

The output module features a switchable low-pass filter to limit the bandwidth of the measurement signal. Three selectable cutoff frequencies (-3 dB) allow for the suppression of higher-frequency noise components in the acoustic and near-ultrasound ranges.

Note the influence of the filter frequency response on the measurement accuracy. Section 3.6.4 provides guidance on using the low-pass filter.

In the OFF position, the filters are switched off and the frequency response of the CLV is determined exclusively by the decoder module.

### 3.6.2 CLV-M002

The partial front panel is shown with the controls in Figure 3.13.

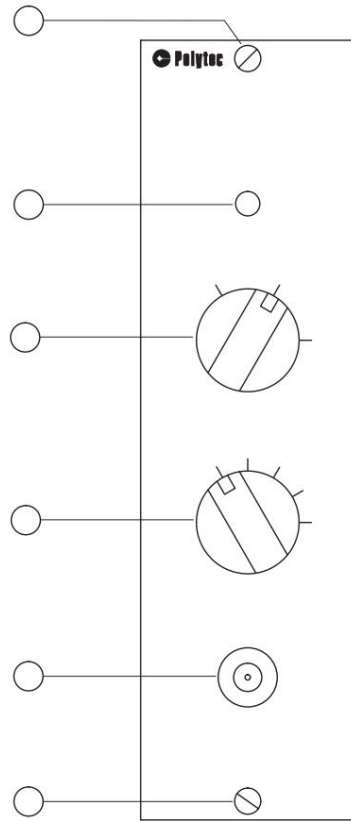

**Knurled screws** for attaching the module

The replacement of modules is described in section 4.7.

**Overload indicator:** The LED

lights up when the output voltage exceeds the range limit.

Rotary switch for the **high-pass filter** : In the

ON position, the high-pass filter is switched on with a cutoff frequency of 100 Hz; in the OFF position, it is switched off. In the R (remote) position, the high-pass filter is remotely controlled (optional).

Rotary switch for the **low-pass filter** : In the

OFF position, the low-pass filter is switched off. In the R (remote) position, the low-pass filter is remotely controlled (optional).

**Analog voltage output (BNC)** for the measurement signal. The alternating voltage is proportional to the instantaneous speed of the object being measured.

Figure 3.13: Partial front panel of the output module CLV-M002

The output module has a switchable low-pass filter to suppress higher-frequency noise components and a switchable high-pass filter to isolate ambient vibrations at frequencies below 100 Hz.

Note the influence of the filter frequency responses on the measurement accuracy. Section 3.6.4 provides guidance on using the filters.

In the OFF position, the filters are switched off and the frequency response of the CLV is determined exclusively by the decoder module.

### 3.6.3 CLV-M003

The partial front panel is shown with the controls in Figure 3.14.

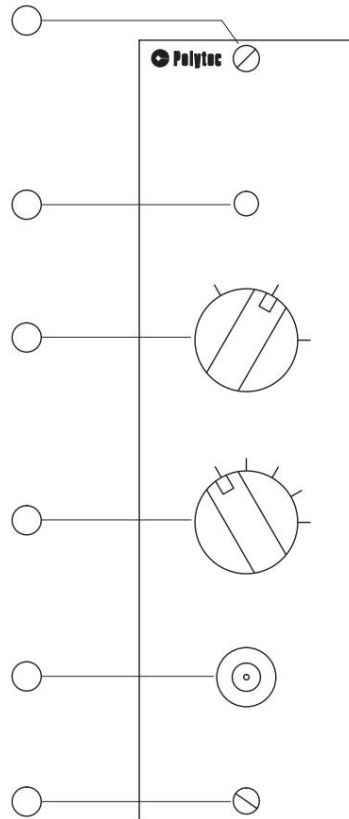

**Knurled screws** for attaching the module

The replacement of modules is described in section 4.7.

**Overload indicator:** The LED

lights up when the output voltage exceeds the range limit.

Rotary switch for the **high-pass filter** : In the

ON position, the high-pass filter is switched on with a cutoff frequency of 10 Hz; in the OFF position, it is switched off. In the R (remote) position, the high-pass filter is remotely controlled (optional).

Rotary switch for the **low-pass filter** : In the

OFF position, the low-pass filter is switched off. In the R (remote) position, the low-pass filter is remotely controlled (optional).

**Analog voltage output (BNC)** for the measurement signal. The alternating voltage is proportional to the instantaneous speed of the object being measured.

Figure 3.14: Partial front panel of the output module CLV-M003

This output module is identical in features to the CLV-M002 output module, differing only in the available filter cutoff frequencies. These are optimized for measurements in the acoustic frequency range. The high-pass filter is designed as an infrasound filter with a cutoff frequency of 10 Hz. When both the high-pass filter and the 30 kHz low-pass filter are engaged, an optimal frequency response is achieved in the range of 15 Hz to 20 kHz with a maximum amplitude error of -0.5 dB at the limits (see [reference]).

Filter frequency responses in section 3.6.4).

### 3.6.4 Use of the filters

The adjustable filters in the output module limit the bandwidth of the measurement signal. If the By displaying the measurement signal in the time domain, the signal-to-noise ratio can be improved. Unwanted components superimposed on the measurement signal, or noise, will be removed. suppressed. Filters play a role in frequency domain analysis, e.g., with an FFT analyzer. They play only a minor role. Here, they can prevent noise effects from overloading the FFT analyzer.

Technically feasible filters, especially analog filters, always represent a challenge. This represents a compromise between the passband and stopband. Therefore, when using these filters... Amplitude and phase errors, which increase with proximity to the corner frequency, are unavoidable.

The CLV is equipped with Butterworth type filters, which provide high amplitude accuracy. most of the passband with a largely linear phase frequency response connect. The errors for each filter can be estimated as follows:

#### Low pass

The low-pass filters are of the third-order Butterworth type. A good rule of thumb is the **70% rule**:

At 70% of the corner frequency, the amplitude error is approximately -5% and the phase shift is approximately  $-90^\circ$ . You can accurately measure the amplitude in this range with good phase linearity.

The upper 30% of the The passage area should only for orienting measurements used ones will be.

#### High pass

The high-pass filters are of the 4th order Butterworth type. The following applies:

At 1.5 times the corner frequency  $f_c$ , the amplitude error is approximately -5%. In this area The amplitude can be measured precisely.

In  $f_c$  ~~at~~ <sup>at</sup>  $f_c$ , the phase is reversed. Switch the high-pass filters if necessary. This phase shift is undesirable.

Another problem is that the decoder may be overdriven.

It is no longer detectable in the measurement signal because the corresponding frequency is filtered out.

This can occur particularly when a small measurement signal is received from a

The measurement signal is superimposed with low-frequency machine vibration with a large amplitude.

In this case, the image is highly distorted. Therefore, proceed as follows if the LED OVER constantly illuminated, although no overload is detectable in the measurement signal:

First, activate the high-pass filter in a measurement out atand She Decoder module the smallest range that is not overloaded. Next, activate the high-pass filter for the actual measurement.

Note that the LED OVER may also be affected by noise spikes resulting from poor optical quality.

The signal quality indicator may briefly light up. However, this does not lead to signal distortion.

Decoder override.

#### Frequency response low-pass filter

The complete amplitude frequency response of a third-order Butterworth low-pass filter is shown in Figure 3.15 is shown on the following page. The frequency is set to the corner frequency  $f_c$ . standardized.

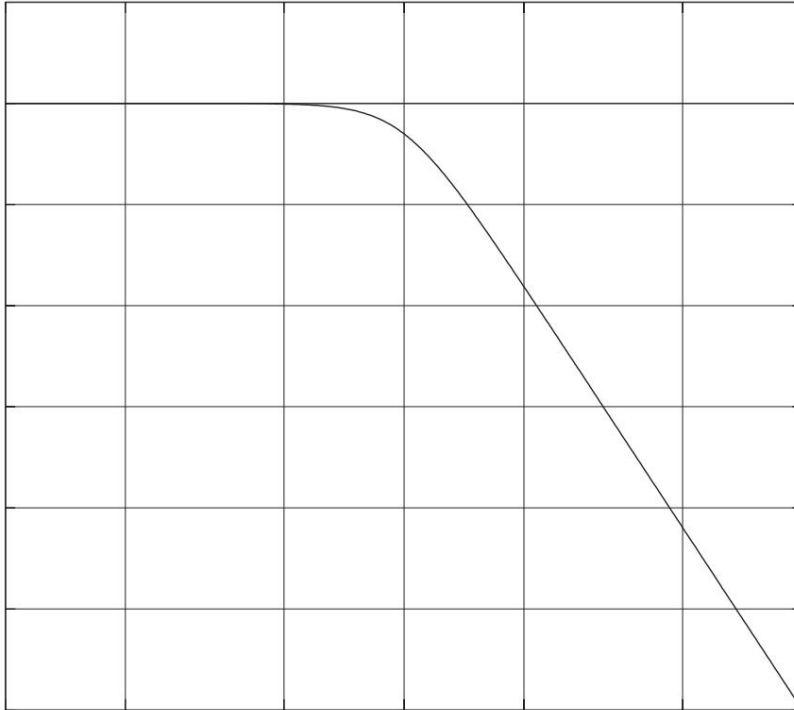

Figure 3.15: Normalized amplitude frequency response of a 3rd order Butterworth low-pass filter

Figure 3.16 shows the amplitude error caused by the filter and Figure 3.17 shows the phase shift in the passband.

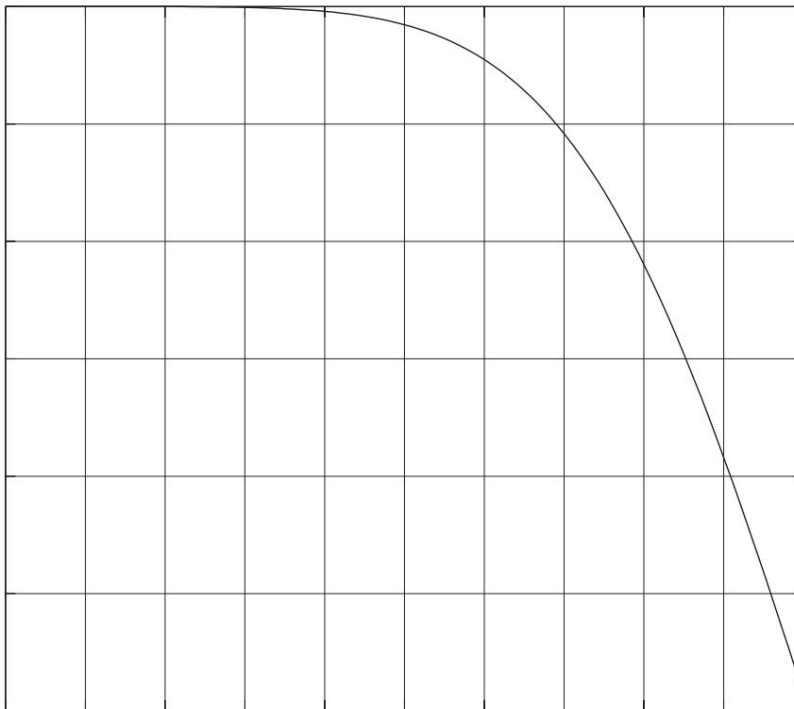

Figure 3.16: Amplitude error of a 3rd order Butterworth low-pass filter in the passband

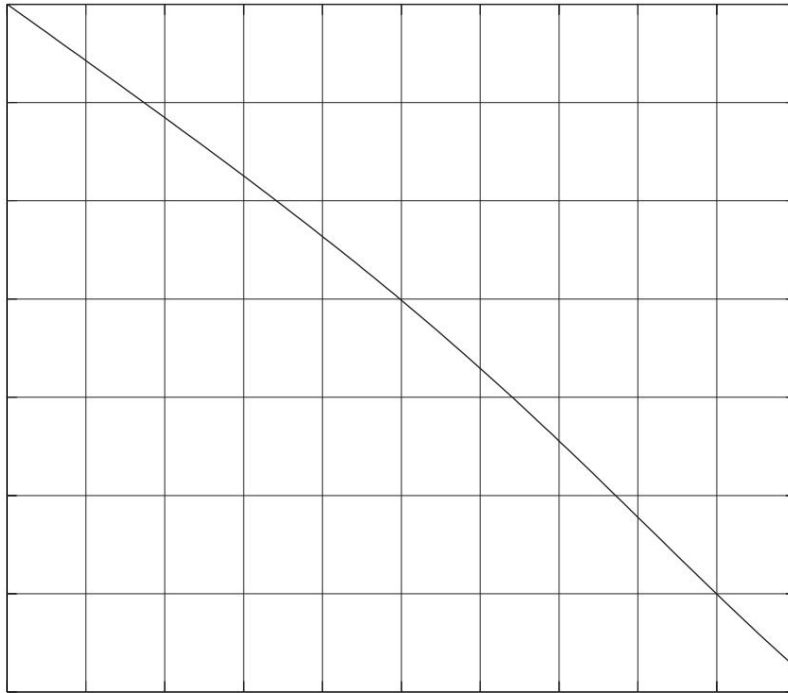

Figure 3.17: Phase shift of a third-order Butterworth low-pass filter in the passband

#### Frequency response high-pass filter

The complete amplitude frequency response of a 4th order Butterworth high-pass filter is shown in Figure 3.18. The frequency is normalized to the corner frequency  $f_c$ .

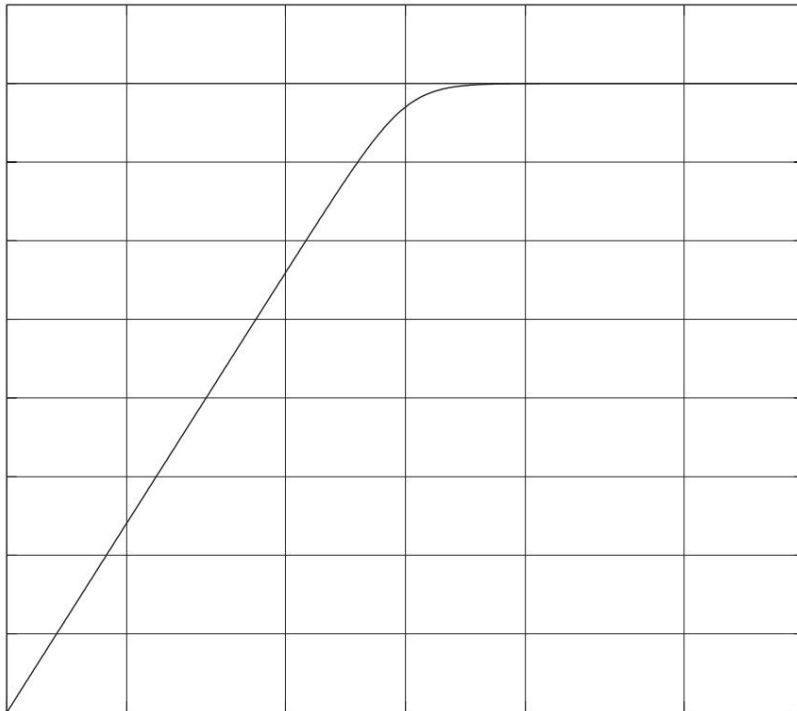

Figure 3.18: Normalized amplitude frequency response of a 4th order Butterworth high-pass filter

Figure 3.19 shows the amplitude error caused by the filter and Figure 3.20 shows the phase shift in the passband.

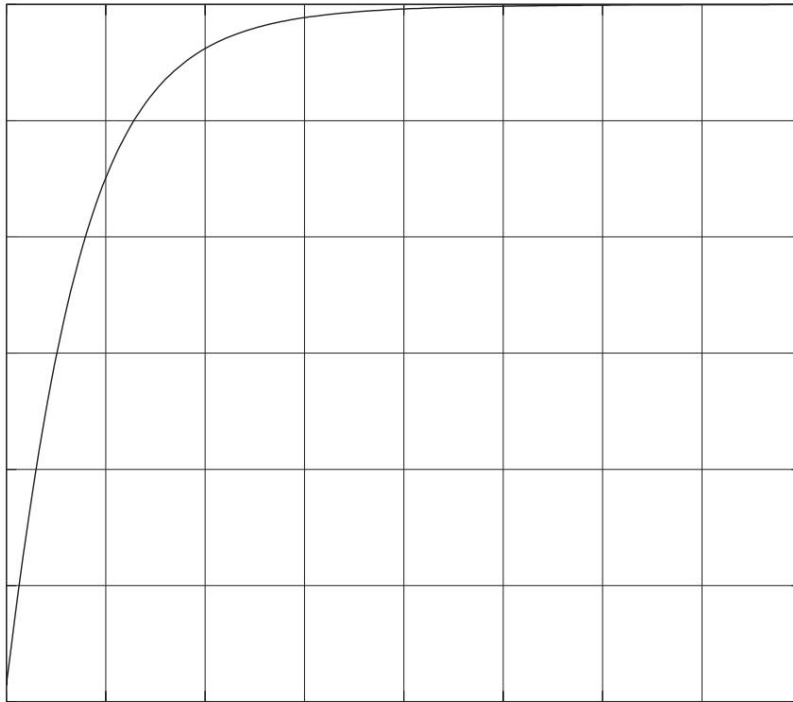

Figure 3.19: Amplitude error of a 4th order Butterworth high-pass filter in the passband

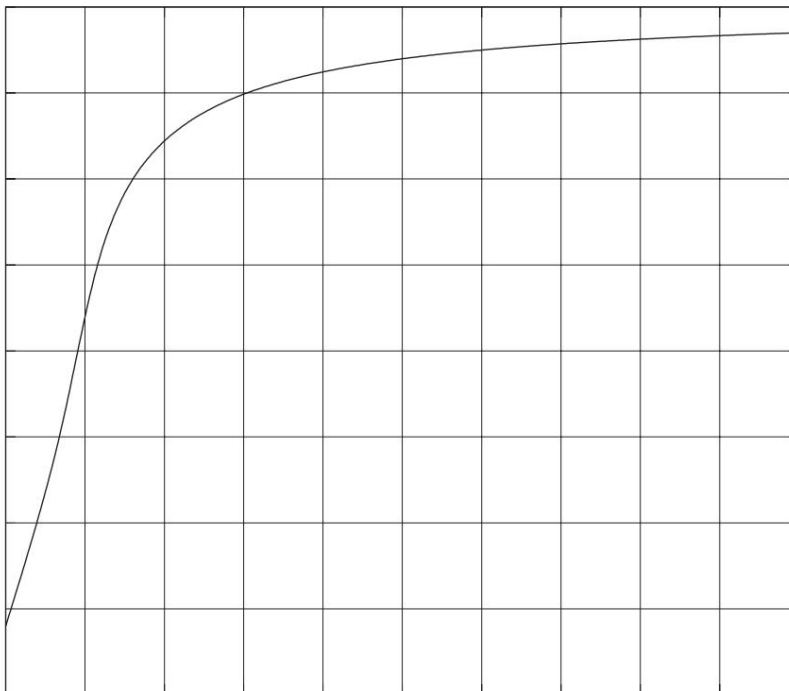

Figure 3.20: Phase shift of a 4th order Butterworth high-pass filter in the passband

## 4 Operating Instructions

### 4.1 Operating and maintenance instructions

#### Assembly

The measuring head must be mounted in a vibration-free manner, ensuring stability for the measured quantity. The mounting surface must be flat (milled), and the screws must be tightened with a maximum torque of 2.5 Nm.

The mounting surface for the external laser module must have a maximum unevenness of 1 mm.

#### network connection

The controller's mains voltage input is a wide-range input and can be connected to any mains voltage with a nominal value between 100 V and 240 V. Always check the mains fuses (2.0 A / slow-blow, independent of the mains voltage) before putting the CLV into operation. Both fuses are active and must be checked in the event of a malfunction.

#### Connection cable

The controller must only be switched on after all connection cables have been connected. Ensure that the connectors are correctly seated and locked in place. Protect the connection cables from mechanical crushing and high temperatures.

#### Cleaning:

The housing surfaces of the devices can be cleaned with mild detergent solutions and ethanol.

#### front lens

Treat the front lens – as with all optical instruments – with great care. The front lens should only be cleaned gently with a soft, dry cloth, an optical brush, and a blower. The front optics of the fixed-focus measuring head can be cleaned after unscrewing the protective cap.

#### cooling

Ensure adequate air circulation to cool the controller. The controller's backplate must be at least 50 mm away from the wall.

#### Modifications to the

**devices:** The intended use of the CLV includes replacing modules in the controller. Always unplug the power cord before removing and installing modules.

Seal any unused slots with blanking plates of the appropriate width.

The measuring head and the individual modules are sealed units. Any intervention is not required during operation and will void the warranty.

## 4.2 Unpacking and inspection

The CLV consists of the following components:

- CLV-1000 Controller
- CLV-700 measuring head
- Schuko mains connection cable

optional

- external laser module CLV-800
- Connection cable from the controller to the external laser module

### Warning!

Handle the front lens of the measuring head very carefully! Contaminants should only be removed gently with a soft, dry cloth, optical brush, and blower.

Please follow these steps when unpacking:

1. After unpacking, check all components for external damage (scratches, loose screws, etc.).
2. Check the packaging for signs of improper handling during the Transport.
3. In case of incorrect deliveries, damage, or missing parts, please inform your nearest Polytec representative immediately, providing the serial numbers of the measuring head and the controller. The identification labels are located on the back of the devices and on the cover of this manual.
4. Carefully retain the original packaging in case of a necessary return.  
on.
5. After unpacking, perform an initial functional test as described in sections 4.3.1 (external laser module) and 4.3.2 (internal laser module).

## 4.3 Functional test

### 4.3.1 CLV with external laser module

For the initial functional test of a CLV with an external laser module, proceed as follows:

1. Ensure that the key switch on the controller is in position O and that the Beam shutter on the back of the external laser module is in the OFF position. If present, switch the high-pass filter on the output module to the OFF position.

2. Plug the connecting cable into the connector on the back of the external device. Laser unit and the connector on the back labeled SENSOR A Controllers. Secure the connections with the existing screws.

All connections must fit easily. Inspect plugs for bent contact pins or serious damage. Otherwise, they to avoid.

3. Connect the controller to a grounded electrical outlet using the power cord.

4. Switch on the controller using the key switch (position I).

The POWER indicator lights up on the front panel of the controller. Furthermore, the light remains on at The emission indicator LASER measuring head is correctly installed with the connecting cable. at Laser radiation must not escape yet, as the beam shutter is still closed.

5. Before you open the beam shutter, remember the instructions for Laser safety in section 1.1!

6. Open the beam shutter on the external laser module by pressing the knurled button. Turn the back panel to ON.

7. Take the measuring head in your hand and point the exit aperture at a matte white test surface, e.g. a sheet of paper.

8. Position the test area approximately 32 cm from the shoulder of the measuring head. Measuring head with variable focus: focus the laser beam with the distance ring. the test area.

If the measuring head and the input module are working correctly, the signal level indicator will light up. on.

9. You can use an oscilloscope to monitor the function of the decoder module and the output.

Check the module. Connect the oscilloscope to the BNC OUT jack of the output. Turn on the module, set it to 1 V/DIV and move the measuring head.

If the decoder module and the output module are working correctly, the voltage displayed on the oscilloscope will at respond to the movement of the measuring head.

If the functional test was successful, you can now install the CLV at the test bench as described in... Section 4.4.1 is described.

If your CLV does not behave as described above, refer to the information given in section 4.6.

For troubleshooting advice, contact your nearest Polytec representative if necessary.

### 4.3.2 CLV with internal laser module

To perform the first functional test of a CLV with an internal laser module, proceed as follows:

1. Ensure that the key switch on the controller is in position O and that the Beam shutter on the front panel of the internal laser module is in the OFF position.  
If present, switch the high-pass filter on the output module to the OFF position.
2. Connect the controller to a grounded electrical outlet using the power cord.
3. Switch on the controller using the key switch (position I).  
The front panel of the [device] comes to light up. The controller's POWER indicator lights up.  
Emissions display with laser measuring head. Laser radiation must not escape yet because the beam shutter is still closed.
4. Before you open the beam shutter, remember the instructions for Laser safety in section 1.1!
5. Open the beam shutter on the internal laser module by pressing the knurled button.  
Turn the front panel to ON.
6. Take the measuring head in your hand and point the exit aperture at a matte white test surface, e.g. a sheet of paper.
7. Position the test area approximately 32 cm from the shoulder of the measuring head.  
Measuring head with variable focus: focus the laser beam with the distance ring.  
the test area.  
  
If the measuring head and the input module are working correctly, the signal level indicator will light up.  
on.
8. You can use an oscilloscope to monitor the function of the decoder module and the output.  
Check the module. Connect the oscilloscope to the BNC OUT jack of the output.  
Turn on the module, set it to 1 V/DIV and move the measuring head.  
  
If the decoder module and the output module are working correctly, the voltage displayed on the oscilloscope will at  
respond to the movement of the measuring head.

If the functional test was successful, you can now install the CLV at the test bench as described in...  
Section 4.4.2 is described.

If your CLV does not behave as described above, refer to the information given in section 4.6.  
For troubleshooting advice, contact your nearest Polytec representative if necessary.

## 4.4 Installation

### 4.4.1 CLV with external laser module

To install a CLV with an external laser module, proceed as follows:

1. Position the measuring head according to the instructions given in section 3.1.3. to the working distances and attach it using the holes on the underside (see. Figure 5.1) vibration-free in the sense of the measured quantity.
  2. If necessary, attach the laser module using the holes on the underside (see diagram). Figure 5.3).
  3. Ensure that the key switch on the controller is in position O and that the The beam shutter on the back of the external laser module must be in the OFF position.
  4. Plug the connecting cable into the connector on the back of the external device. Laser unit and the connector on the back labeled SENSOR A Controllers. Secure the connections with the existing screws. All connections must fit easily. Inspect plugs for bent contact pins or serious damage. Otherwise, they to avoid.
  5. Connect the controller to a grounded electrical outlet using the power cord.
  6. Switch on the controller using the key switch (position I). The POWER indicator lights up on the front panel of the controller. Furthermore, the light remains on at The emission indicator LASER measuring head is correctly installed with the connecting cable. at Laser radiation cannot escape yet, as it is still closed. Beam closure permitted.
  7. Before you open the beam shutter, remember the instructions for Laser safety in section 1.1!
  8. Open the beam shutter on the laser module by turning the knob to ON.
- You can now measure with the CLV as described in section 4.5.

### 4.4.2 CLV with internal laser module

To install a CLV with an internal laser module, proceed as follows:

1. Position the measuring head according to the instructions given in section 3.1.3. to the working distances and attach it using the holes on the underside. (see Figure 5.1) vibration-free in the sense of the measured quantity.
  2. Ensure that the key switch on the controller is in position O and that the The beam shutter on the internal laser module must be in the OFF position.
  3. Connect the controller to a grounded electrical outlet using the power cord.
  4. Switch on the controller using the key switch (position I). The POWER indicator lights up on the front panel of the controller. The light continues to shine Emissions display with laser measuring head. Laser radiation must not escape yet. because the beam shutter is still closed.
  5. Before you open the beam shutter, remember the instructions for Laser safety in section 1.1!
  6. Open the beam shutter on the laser module by turning the knob to ON.
- You can now measure with the CLV as described in section 4.5.

## 4.5 Operating the CLV

### On/Off

You switch on the CLV using the key switch on the front panel. To do this, turn the key switch to position I. The lamp next to the key switch will light up, indicating that the controller is ready for operation and that the laser is active; that is, the lamp will also light up when the mechanical beam shutter is closed (see below).

### Beam shutter and emission indicator

The laser beam can be blocked using the mechanical beam shutter on the back of the external laser module or on the front panel of the internal laser module. To do this, turn the knob to the OFF position. The laser LED on the measuring head indicates laser activity; that is, the LED remains lit even when the beam shutter is closed.

### Focusing: With

the variable focus measuring head, the working distance can be changed using the distance ring. When looking in the direction of the emitted beam, focus to infinity by turning left and to close distance by turning right.

### Signal Level Display:

The level of the optical signal is displayed on the front panel of the input module as a 20-segment bar graph and on the measuring head as a 10-segment bar graph. The signal level is also available at the control interface (see below).

### Measuring range and filter setting

Measuring ranges and filters are set on the front panels of the modules using rotary switches. The detented rotary switches are interference-resistant and relatively safe against unintentional adjustments. In position R (remote), the settings are controlled remotely (optional).

### Measurement

**signal output:** The measurement signal can be tapped as an analog voltage signal at the BNC OUT socket on the front panel of the output module.

### Overload indicator

The LED OVER on the output module remains lit, indicating that the output voltage exceeds the range's end value. In this case, the next higher measuring range must be selected.

The

**CLV** supports manually triggered signal acquisition and evaluation. When the TRIGGER button on the measuring head is pressed, a falling signal edge (+5 V  $\rightarrow$  0 V) is generated at the TRIGGER BNC connector on the controller's rear panel. This signal can be used to start external signal acquisition.

### Control interface

The 25-pin D-sub connector on the controller's rear panel provides additional input and output signals. This facilitates the integration of the CLV into automated measurement systems. The following are available as standard:

- Trigger signal (see above)
  - Overload warning (corresponds to the OVER indicator on the output module) •
- Signal level, i.e., a DC signal proportional to the logarithm of the optical signal strength (corresponds to the bar display on the input module and the measuring head)

## 4.6 Troubleshooting

The following are simple tests that you can perform yourself in case of malfunctions.

This means that no laser beam or measurement signal is emitted.

is available. In case of more complex malfunctions with individual functions, please contact us.

Please ask our service staff. The tests described here are not intended to encourage you to try them yourself.

not to carry out maintenance work, but to provide our service personnel with the most detailed information possible

Please inform us. Unauthorized opening of the casing will void the warranty.

If the CLV needs to be sent in for repair, please use the original packaging.

and include as precise a description of the error as possible.

If no laser beam exits the measuring head, perform the following steps in the

Follow the steps in the specified order. After each step, check if the problem has been resolved.

is.

If a laser beam is emitted, but no measurement signal is present at the BNC OUT connector on the output module

If this is available, you can skip the following sections and proceed with the tests on the

Controller continued in section 4.6.4.

If needed, please contact our service department. Based on your

The error description determines the further course of action.

### 4.6.1 General Tests

1. Is the network connection to the controller established?
2. Is the power switch in position I?
3. Is the POWER indicator on the front panel of the controller illuminated?

**Caution !**

Always unplug the power cord before opening the casing!

If not, a fault in the mains power supply is likely. In this case, unplug the mains plug and check the fuses to ensure that there are two active fuses, both of which could fail. to They suspect. Move in to the backplate. Note

4. Is the LED LASER on the measuring head illuminated?

5. Is the beam shutter open?

### 4.6.2 Tests with external laser module

For a CLV with an external laser module, please also check:

1. Is the connection cable between the controller and the external laser unit installed correctly?
2. Are the connectors of the connecting cable screwed in tightly?
3. If the housing of the external laser module shows normal signs of wear after approximately 15 minutes of operation, Can a perceptible warming sensation be an indication of a working laser?
4. Is there any sign of a break in the connecting cable between the laser module and the measuring head?
5. If you have a second external laser module available, replace it.

#### 4.6.3 Tests with internal laser module

For a CLV with an internal laser module, please also check:

1. Does the controller housing point towards the position of the internal laser module at approximately 15 degrees? After 15 minutes of operation, a normal, perceptible warming is an indication of a working laser?
2. Is there any sign of a break in the connecting cable between the laser module and the measuring head?

#### 4.6.4 Controller Tests

Place a matte white test surface, e.g. a sheet of paper, at a distance of approximately 32 cm from the the shoulder of the measuring head into the beam path. With a measuring head with variable focus Focus the laser beam onto the test area using the distance ring.

1. Is the signal level indicator on the input module responding?

If the signal level indicator is not defective, reacts, either the Optics or the Input module proceed to step 4. around that disruption to locate.

2. Connect an oscilloscope to the BNC OUT jack on the output module and check You, whether the output now reacts to movement of the test area.

If the output does not respond, check if a significant DC offset is displayed. becomes. Normally, a DC voltage of less than 20 mV is measured. ±

3. Set the oscilloscope to 1 V/DIV and block the laser beam. Is that Is the output signal noisy, or does the oscilloscope show a straight line?

Noise **must** occur if the laser beam is blocked.

4. If you have a second set of interchangeable modules, you can now successively Replace the individual modules as described in section 4.7 to correct a faulty module. To locate the module.

You replace the decoder and output modules in the input sequence.

The assignment of modules is irrelevant; you use measurement range 5 for the test.

$$\frac{\text{mm}}{\text{s}} / \text{V}$$

The  
the

## 4.7 Module Replacement

If you need to replace modules due to malfunctions, first refer to the troubleshooting instructions in section 4.6. If you are installing new modules to adapt your CLV to a new application, refer to section 4.8 regarding the selection of new module sets.

**The following modules are not interchangeable and may only be replaced by trained personnel:**

- **Power supply**
- **Internal laser module CLV-M000.L • Battery module CLV-M000.6**

**In this case, please contact Polytec.**

When replacing a module, proceed as follows:

**Caution !**

Always unplug the power cord before opening the casing!

1. Loosen the knurled screws at the top and bottom of the partial front panel and pull the module out of the controller using the knurled screws.
2. When choosing the position of the new module, refer to Table 2.1.
3. Slide the new module into the controller and tighten the knurled screws.  
concrete.
4. Close any unused slots with blanking plates of the appropriate width, see Table 2.1.

## 4.8 Selection of new module sets

The flexible modular system allows you to adapt your CLV to a new application. A module overview can be found in section 2.4, and detailed module descriptions in chapter 3. When selecting a customized module set, please note the following:

- One input module, one decoder module, and one output module must be selected.
- A maximum of three additional slots are available for expansion modules, as well as space for the internal laser unit.
- The position of the modules in the controller must be selected according to Table 2.1.

When selecting the modules, proceed as follows:

1. Select the decoder module according to your application. See section 3.5 for instructions.
2. Match the input module to the decoder module, see section 5.1.2.
3. Select the output module depending on the desired frequency range or the subsequent signal processing.
4. Select the required add-on modules.
5. Select between the internal and external laser module according to the instructions in section 3.2.
6. Determine the number and width of the unused slots. These must be filled with Blank front panels (1, 2 or 3 slots wide) can be covered.

## 5 Technical Specifications

### 5.1 Controller CLV-1000

#### 5.1.1 General Data

Mains voltage:	100 ... 240 VAC $\pm$ 10%, 50/60 Hz
Power consumption:	max. 80 VA
Fuses:	2.0 A/slow-blow
Protection class:	I (protective earthing)
Operating temperature:	+5°C ... +40°C
Storage temperature:	-5°C ... +60°C
Humidity:	max. 80%, non-condensing
Dimensions:	450 mm x 355 mm x 134 mm
Weight:	min. 7.2 kg, depending on the module configuration
Recommended calibration interval:	2 years

#### Applied harmonized standards

Electrical safety:	EN 60950 (DIN VDE 0805), EN 61010
EMC:	Emission: EN 50081-1 (DIN VDE 0871 Class B) Immunity: EN 50082-1, EN 50082-2 (VDE 0843-2...-5)
Laser safety:	EN 60825-1 (DIN VDE 0837)

#### interfaces

TRIGGER - Output (BNC): Falling signal edge when pressing the TRIGGER button on the CLV-700 (nom. +5 V/0 V)

RS-232: optional serial interface, in Preparation

CONTROL interface:  
(25-pin D-Sub) Pin assignment as seen from the outside of the socket:

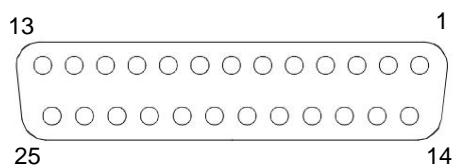

Pin 1 GND, reference potential

Pin 4, 23 signal level, nom. 0V...5V DC proportional to the logarithm of the RF signal level, Load impedance  $\geq$  10 k $\Omega$

Pin 5, 22 Overrange, TTL overload indicator, HIGH-active

Pin 6, 19 +15 V, operating voltage U2

Pin 7, 20 + 5 V, operating voltage U1

Pin 8 -15 V, operating voltage U4

Pin 13, 14 trigger output, nom. +5V / 0V

Unlabeled pins do not carry signals by default and must not be connected.

### 5.1.2 Input Module

#### General data

Width:	1 slot (7 HP)
Input signal frequency:	70 MHz
Signal level indicator:	LED bar, 20 dots
Tracking filter:	logarithmic, approx. 1.5 dB/dot Internally switchable NARROW / WIDE

#### Area of application

Input module	max. speed (peak) ms <sup>-1</sup>	suitable for decoder module
CLV-M100	0.1	CLV-M010
CLV-M200	1.5	CLV-M020 CLV-M030

### 5.1.3 Decoder Module

#### General data

Width:	1 slot (7 HP)
Calibration accuracy:	±2% of the measured value Reference conditions: Sinusoidal oscillation, f=1 kHz, amplitude 70% from the end-range value, load impedance $\dot{y}$ 1 M $\ddot{y}$
Linearity error:	max. ±1% of the measured value The linearity error is defined as the amplitude-dependent, relative Deviation of the scaling factor relative to the nominal scaling factor under reference conditions.
Total harmonic distortion:	< 1% THD (f = 1 kHz, 70% of the full-scale value)

Noise-free dynamic range: > 86 dB for f < 20 kHz  
(SFDR) > 80 dB for f > 20 kHz

#### Measuring ranges

decoder module	Measuring range (Scaling factor) mms-1/V	Final value (Peak to Peak) mms-1	resolution <sup>1</sup> $\mu$ mms-1	Maximum frequency kHz	Max. acceleration G
CLV-M010	1	20	0.1	20	150
	5	100	0.5	50	1,600
CLV-M020	5	100	0.5	50	1,600
	25	500	0.8	50	8,000
CLV-M030	5	100	0.5	250	8,000
	25	500	1.5	250	40,000
	125	2,500	2	250	200,000

<sup>1</sup> Resolution is defined as the effective value of the signal amplitude (RMS) at a signal-to-noise ratio of 0 dB and at a spectral resolution of 10 Hz.

**Frequency response**

decoder module	Measuring range mms-1/V	Maximum additional error relative to $f = 1$ kHz
CLV-M010 and CLV-M020	1	0.5 Hz - 10 Hz: $\pm 0.5$ dB 10 Hz - 10 kHz: $\pm 0.1$ dB 10 kHz - 20 kHz: $+0.1/-1.5$ dB
	5 and 25	0.5 Hz - 10 Hz: $\pm 0.5$ dB 10 Hz - 20 kHz: $\pm 0.1$ dB 20 kHz - 50 kHz: $\pm 0.3$ dB
CLVD-M030	5	0.5 Hz - 10 Hz: $\pm 0.5$ dB 10 Hz - 100 kHz: $\pm 0.2$ dB 100 kHz - 250 kHz: $+0.1/-1$ dB
	25 and 125	0.5 Hz - 10 Hz: $\pm 0.5$ dB 10 Hz - 250 kHz: $\pm 0.25$ dB

**5.1.4 Output Module****General data**

Width:	1 slot (7 HP)
Voltage swing:	$\pm 12$ V
Source impedance:	50 $\Omega$
Minimum load impedance:	10 k $\Omega$ (-0.5% additional error)
Threshold of the	
Overload indicator:	typically 95% of the full-scale value
DC offset:	max. $\pm 20$ mV

**Low-pass filter** (typical amplitude error and phase delay see section 3.6.4)

Filter type:	Butterworth 3rd order
Corner frequencies:	See Table 5.1
Steepness:	-60 dB/dec = -18 dB/oct
Attenuation:	> 70 dB

**High-pass filter** (typical amplitude error and phase delay see section 3.6.4)

Filter type:	Butterworth 4th order
Corner frequencies:	see Table 5.1
Slope:	-80 dB/dec = -24 dB/oct
Attenuation:	> 70 dB

**Filter corner frequencies**

Output Module	Corner frequencies (-3 dB)	
	Low pass kHz	High pass Hz
CLV-M001	5 / 20 / 50	-
CLV-M002	5 / 20 / 100	100
CLV-M003	5 / 15 / 30	10

Table 5.1: Adjustable filter cutoff frequencies of the output modules

## 5.2 Measuring head CLV-700

Laser type:	Helium-neon
Wavelength:	633 nm
Resonator length:	205 mm
Laser class:	II
Laser power:	< 1 mW
Power consumption:	approx. 1 W
Protection class:	IP 64
Operating temperature:	+0°C ... +40°C
Storage temperature:	-5°C ... +50°C
Dimensions:	See Figure 5.1 and Figure 5.2
Weight:	0.5 kg
Cable diameter:	10 mm
Cable length:	Standard 3 m, optional up to 10 m
Minimum radius of curvature:	40 mm

variant	fixed focus (ff)	variable focus (vf)
Working distance <sup>2</sup>	316 mm	266 mm ... approx. 10 m <sup>3</sup>
Resolution	0.1 µm at 10 Hz spectral resolution <sup>4</sup>	
Exit jet diameter (1/e <sup>2</sup> ) (typ.) mm	2	8
Beam diameter (typ.) µm		
at 316 mm	160	45
at 1 m (and for each additional meter)	-	180
Coherence maxima <sup>2</sup> mm		
first	316	316
next all	-	205

<sup>2</sup> Measured from the shoulder of the measuring head, see Figure 5.1 and Figure 5.2 on the following page.

<sup>3</sup> The maximum working distance depends on the surface properties of the object being measured.

<sup>4</sup> 3M Scotchlite Tape® at a working distance of 316 mm, measuring range 5 mm/s

## Dimensions

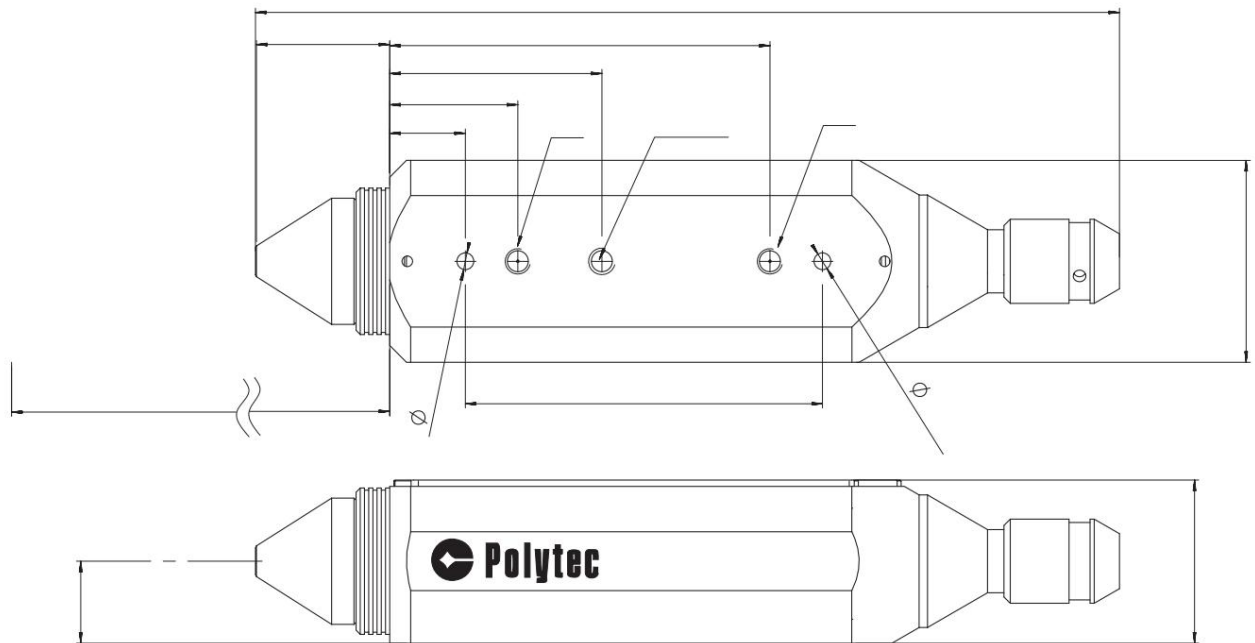

Figure 5.1: Bottom and side views of the CLV-700 measuring head, fixed focus variant. Dimensions are given in mm.

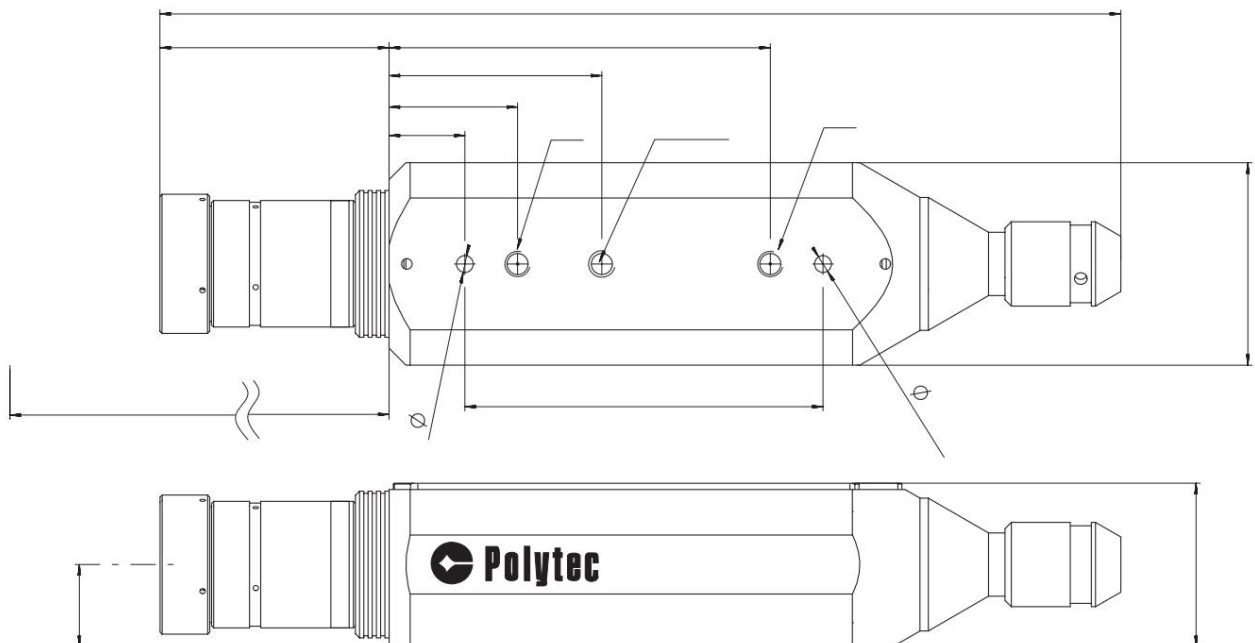

Figure 5.2: Bottom and side views of the CLV-700 measuring head, variable focus variant. Dimensions are given in mm.

### 5.3 External laser module CLV-800

Power consumption:	approx. 15 W
Protection class:	IP 64
Operating temperature:	+0°C ... +40°C
Storage temperature:	-5°C ... +60°C
Weight:	5.5 kg

#### Dimensions

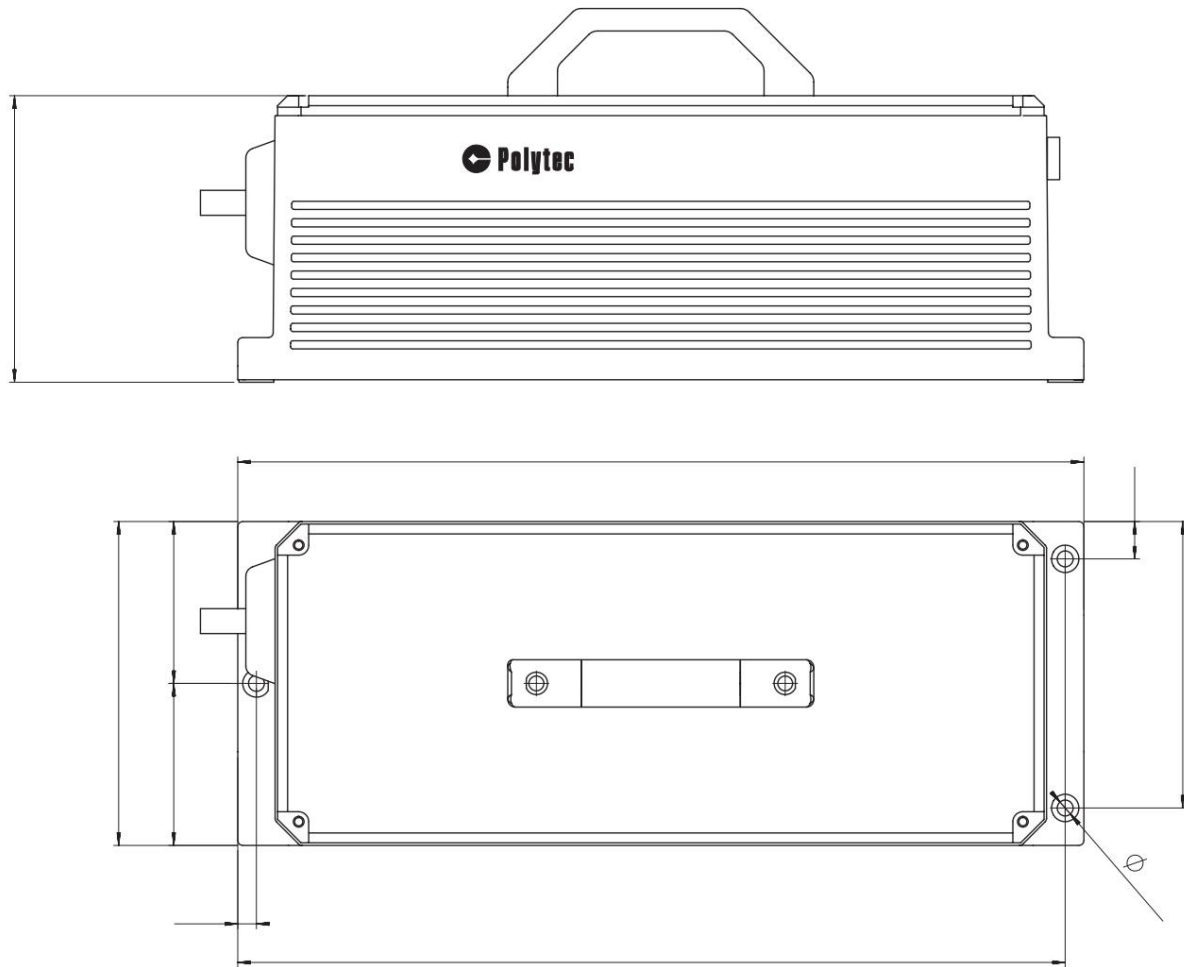

Figure 5.3: Side view and top view of the external laser module CLV-800. Dimensions are given in mm.